



MIC5365/6 Evaluation Board

High Performance Single 150mA LDO

General Description

The MIC5365/6 is an advanced general purpose linear regulator. The MIC5365/6 is capable of sourcing 150mA output current with high PSRR and low output noise. When the MIC5366 is disabled an internal resistive load is automatically applied to the output to discharge the output capacitor. Both the MIC5365 and MIC5366 are available in a 4-pin 1mm x 1mm Thin MLF[®], as well as the SC-70-5 packages.

The MIC5365/6 linear regulator is easy to use. A small output capacitance of only 1 μ F for the output is required.

An input capacitor may be required when the power supply is more than 4-inches away from the device. The evaluation board includes an input capacitor of 10 μ F to compensate for long inductive test leads.

Requirements

The MIC5365/6 evaluation board requires an input power source that is able to deliver at least 200mA at a voltage within the range of 2.5V to 5.5V. The output load can be either active or passive.

Precautions

The evaluation board does not have reverse polarity protection. Applying a negative voltage to the V_{IN} terminal may damage the device.

The MIC5365/6 evaluation board is tailored for a Li-Ion range input supply voltage. It should not exceed 5.5V on the input.

Getting Started

1. **Connect an external supply to V_{IN} .** Apply the desired input voltage to the V_{IN} (J1) and ground terminal (J2) of the evaluation board, paying careful attention to polarity and supply voltage ($2.5V \leq V_{IN} \leq 5.5V$). An ammeter may be placed between the input supply and the V_{IN} terminal to the evaluation board. Ensure that the supply voltage is monitored at the V_{IN} terminal. Ammeter and/or power lead resistance can reduce the voltage supplied to the input.
2. **Enable/Disable the MIC5365/6.** The evaluation board is set up for "Default Disable" with a 100k pull down resistor on the enable pin (EN) to GND. To enable the output, simply jumper the EN terminal (J5) to the V_{IN} terminal (J1). The enable pin must be either pulled high or low for proper operation. Removing the pull down resistor and leaving the pin floating will cause the regulator to operate in an indeterminate state.
3. **Connect the load to the V_{OUT} terminal (J3) and ground terminal (J4).** The load can be either a passive (resistor) or active (electronic load). Be sure to monitor the output voltage at the V_{OUT} (J3) terminal.

Ordering Information

Part Number	Description
MIC5365-1.0YMT EV	150mA LDO, Vout=1.0V, 1mmx1mm Thin MLF [®] Evaluation board.
MIC5365-1.2YMT EV	150mA LDO, Vout=1.2V, 1mmx1mm Thin MLF [®] Evaluation board.
MIC5365-1.5YMT EV	150mA LDO, Vout=1.5V, 1mmx1mm Thin MLF [®] Evaluation board.
MIC5365-1.8YMT EV	150mA LDO, Vout=1.8V, 1mmx1mm Thin MLF [®] Evaluation board.
MIC5365-2.6YMT EV	150mA LDO, Vout=2.6V, 1mmx1mm Thin MLF [®] Evaluation board.
MIC5365-2.8YMT EV	150mA LDO, Vout=2.8V, 1mmx1mm Thin MLF [®] Evaluation board.
MIC5365-2.85YMT EV	150mA LDO, Vout=2.85V, 1mmx1mm Thin MLF [®] Evaluation board.
MIC5365-2.9YMT EV	150mA LDO, Vout=2.9V, 1mmx1mm Thin MLF [®] Evaluation board.
MIC5365-3.0YMT EV	150mA LDO, Vout=3.0V, 1mmx1mm Thin MLF [®] Evaluation board.
MIC5365-3.3YMT EV	150mA LDO, Vout=3.3V, 1mmx1mm Thin MLF [®] Evaluation board.
MIC5365-1.0YC5 EV	150mA LDO, Vout=1.0V, SC-70-5 Evaluation board.
MIC5365-1.2YC5 EV	150mA LDO, Vout=1.2V, SC-70-5 Evaluation board.
MIC5365-1.5YC5 EV	150mA LDO, Vout=1.5V, SC-70-5 Evaluation board.
MIC5365-1.8YC5 EV	150mA LDO, Vout=1.8V, SC-70-5 Evaluation board.
MIC5365-2.6YC5 EV	150mA LDO, Vout=2.6V, SC-70-5 Evaluation board.
MIC5365-2.8YC5 EV	150mA LDO, Vout=2.8V, SC-70-5 Evaluation board.
MIC5365-2.85YC5 EV	150mA LDO, Vout=2.85V, SC-70-5 Evaluation board.
MIC5365-2.9YC5 EV	150mA LDO, Vout=2.9V, SC-70-5 Evaluation board.
MIC5365-3.0YC5 EV	150mA LDO, Vout=3.0V, SC-70-5 Evaluation board.
MIC5365-3.3YC5 EV	150mA LDO, Vout=3.3V, SC-70-5 Evaluation board.
MIC5366-1.0YMT EV	150mA LDO with auto discharge, Vout=1.0V, 1mmx1mm Thin MLF [®] Evaluation board.
MIC5366-1.2YMT EV	150mA LDO with auto discharge, Vout=1.2V, 1mmx1mm Thin MLF [®] Evaluation board.
MIC5366-1.5YMT EV	150mA LDO with auto discharge, Vout=1.5V, 1mmx1mm Thin MLF [®] Evaluation board.
MIC5366-1.8YMT EV	150mA LDO with auto discharge, Vout=1.8V, 1mmx1mm Thin MLF [®] Evaluation board.
MIC5366-2.6YMT EV	150mA LDO with auto discharge, Vout=2.6V, 1mmx1mm Thin MLF [®] Evaluation board.
MIC5366-2.8YMT EV	150mA LDO with auto discharge, Vout=2.8V, 1mmx1mm Thin MLF [®] Evaluation board.

MIC5366-2.85YMT EV	150mA LDO with auto discharge, Vout=2.85V, 1mmx1mm Thin MLF [®] Evaluation board.
MIC5366-2.9YMT EV	150mA LDO with auto discharge, Vout=2.9V, 1mmx1mm Thin MLF [®] Evaluation board.
MIC5366-3.0YMT EV	150mA LDO with auto discharge, Vout=3.0V, 1mmx1mm Thin MLF [®] Evaluation board.
MIC5366-3.3YMT EV	150mA LDO with auto discharge, Vout=3.3V, 1mmx1mm Thin MLF [®] Evaluation board.
MIC5366-1.0YC5 EV	150mA LDO with auto discharge, Vout=1.0V, SC-70-5 Evaluation board.
MIC5366-1.2YC5 EV	150mA LDO with auto discharge, Vout=1.2V, SC-70-5 Evaluation board.
MIC5366-1.5YC5 EV	150mA LDO with auto discharge, Vout=1.50V, SC-70-5 Evaluation board.
MIC5366-1.8YC5 EV	150mA LDO with auto discharge, Vout=1.80V, SC-70-5 Evaluation board.
MIC5366-2.6YC5 EV	150mA LDO with auto discharge, Vout=2.60V, SC-70-5 Evaluation board.
MIC5366-2.8YC5 EV	150mA LDO with auto discharge, Vout=2.80V, SC-70-5 Evaluation board.
MIC5366-2.85YC5 EV	150mA LDO with auto discharge, Vout=2.85V, SC-70-5 Evaluation board.
MIC5366-2.9YC5 EV	150mA LDO with auto discharge, Vout=2.90V, SC-70-5 Evaluation board.
MIC5366-3.0YC5 EV	150mA LDO with auto discharge, Vout=3.0V, SC-70-5 Evaluation board.
MIC5366-3.3YC5 EV	150mA LDO with auto discharge, Vout=3.3V, SC-70-5 Evaluation board.

Evaluation Board Schematics

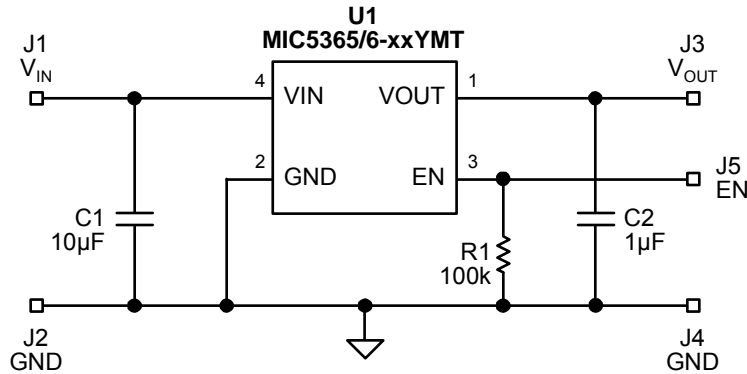

Bill of Materials

Item	Part Number	Manufacturer	Description	Qty.
C1	C1608X5R0J106Z	TDK ⁽¹⁾	Capacitor, 10µF Ceramic, 6.3V, X5R, Size 0603	1
C2	GRM155R61A105KE15D	Murata ⁽²⁾	Capacitor, 1µF Ceramic, 10V, X5R, Size 0402	1
R1	CRCW0603100KFKEA	Vishay ⁽³⁾	Resistor, 100kΩ, 1%, 1/16W, Size 0603	1
U1	MIC5365/6-xxYMT	Micrel, Inc. ⁽⁴⁾	High Performance Single 150mA LDO	1

Notes:

1. TDK: www.tdk.com
2. Murata: www.murata.com
3. Vishay: www.vishay.com
4. **Micrel, Inc.:** www.micrel.com

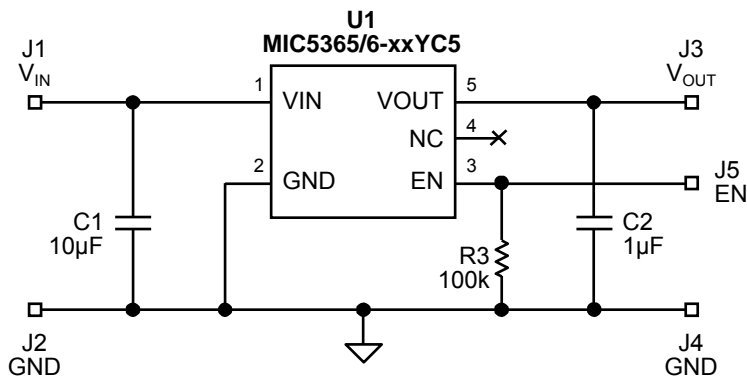

Bill of Materials

Item	Part Number	Manufacturer	Description	Qty.
C1	C1608X5R0J106Z	TDK ⁽¹⁾	Capacitor, 10µF Ceramic, 6.3V, X5R, Size 0603	1
C2	GRM155R61A105KE15D	Murata ⁽²⁾	Capacitor, 1µF Ceramic, 10V, X5R, Size 0402	1
R3	CRCW0603100KFKEA	Vishay ⁽³⁾	Resistor, 100kΩ, 1%, 1/16W, Size 0603	1
U1	MIC5365/6-xxYC5	Micrel, Inc. ⁽⁴⁾	High Performance Single 150mA LDO	1

Notes:

1. TDK: www.tdk.com
2. Murata: www.murata.com
3. Vishay: www.vishay.com
4. **Micrel, Inc.:** www.micrel.com

PCB Layout Recommendations (1mm x 1mm MLF[®])

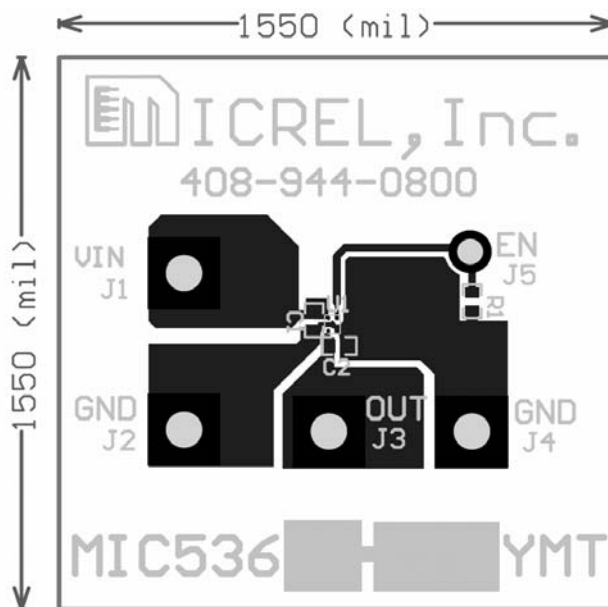

Top Layer

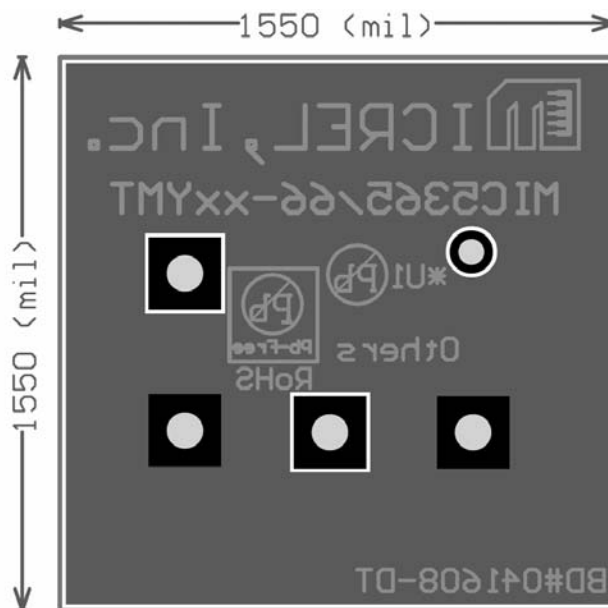

Bottom Layer

PCB Layout Recommendations (SC-70-5)

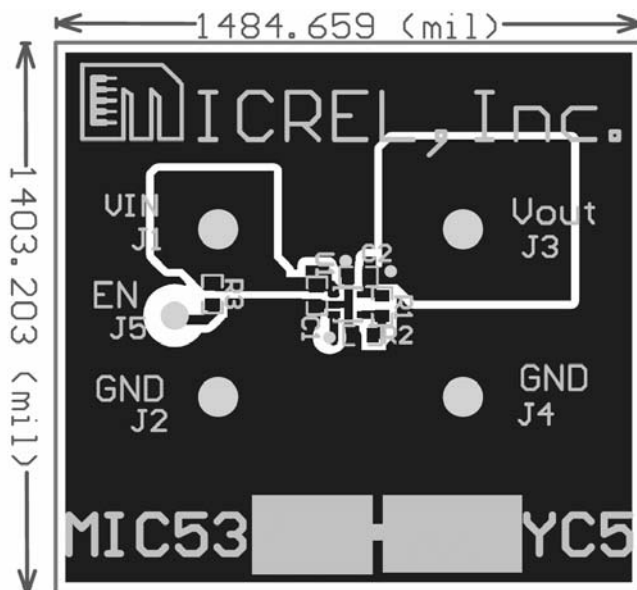

Top Layer

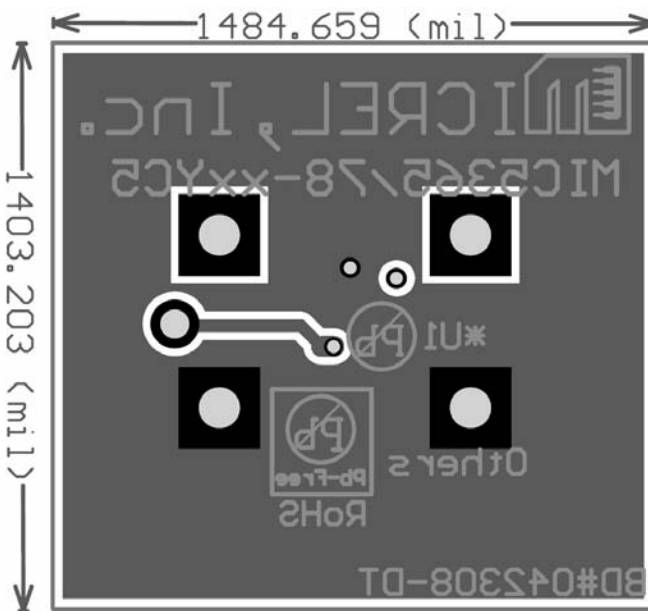

Bottom Layer

MICREL, INC. 2180 FORTUNE DRIVE SAN JOSE, CA 95131 USA
TEL +1 (408) 944-0800 FAX +1 (408) 474-1000 WEB <http://www.micrel.com>

The information furnished by Micrel in this data sheet is believed to be accurate and reliable. However, no responsibility is assumed by Micrel for its use. Micrel reserves the right to change circuitry and specifications at any time without notification to the customer.

Micrel Products are not designed or authorized for use as components in life support appliances, devices or systems where malfunction of a product can reasonably be expected to result in personal injury. Life support devices or systems are devices or systems that (a) are intended for surgical implant into the body or (b) support or sustain life, and whose failure to perform can be reasonably expected to result in a significant injury to the user. A Purchaser's use or sale of Micrel Products for use in life support appliances, devices or systems is a Purchaser's own risk and Purchaser agrees to fully indemnify Micrel for any damages resulting from such use or sale.

© 2008 Micrel, Incorporated.