

New



- * Bearing Type
Ball Bearings
- * Material
Impeller & Pillow : Plastic(UL 94V-0)
- * Lead Wires :
UL 1571 AWG #24 OR Equivalent
Red Wire Positive(+)
Black Wire Negative(-)
- * Weight : 35g (1.23 OZ)

FFB 40 x 40 x 28 MM SERIES

■ DIMENSIONS DRAWING

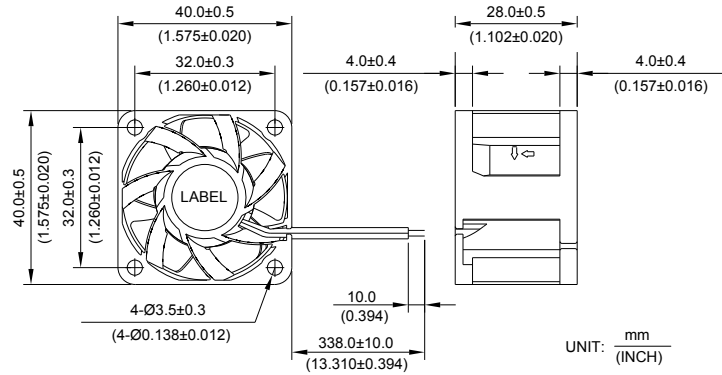

■ P & Q CURVE (AT RATED VOLTAGE)

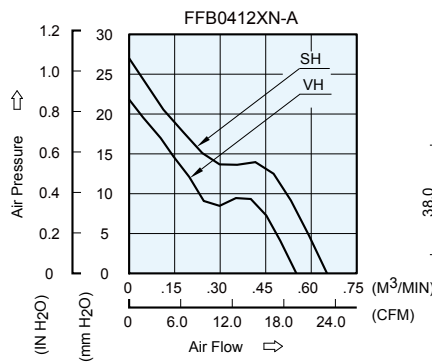

■ MOUNTING PANEL CUTOUT

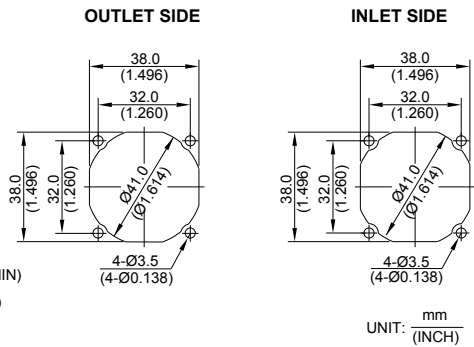

MODEL			Rated Voltage	Operating Voltage Range	Input Current	Input Power	Speed	Maximum Air Flow		Maximum Air Pressure		Noise
PART NO.	REV.	FUNCTION	VDC	VDC	Amp	Watt	R.P.M.	m ³ /min	CFM	mmH ₂ O	IN H ₂ O	dB-A
FFB0412VHN	-A	-R00/-F00	12	4.0 to 12.6	0.30	3.60	11000	0.543	19.16	18.99	0.748	48.5
FFB0412SHN	-A	-R00/-F00	12	4.0 to 12.6	0.40	4.80	13000	0.653	23.05	27.07	1.066	52.5

- * Function type is optional.
- * The max. air flow and the speed are measured in free air ; max. air pressure is measured at zero air flow.
- * Noise is measured in anechoic chamber in free air, one meter from intake side.
- * All readings are typical values at rated voltage.
- * Specifications are subject to change without notice.