

Micro Fuse



3.6 x 10mm - Time-Lag (T)



Mechanical Dimensions

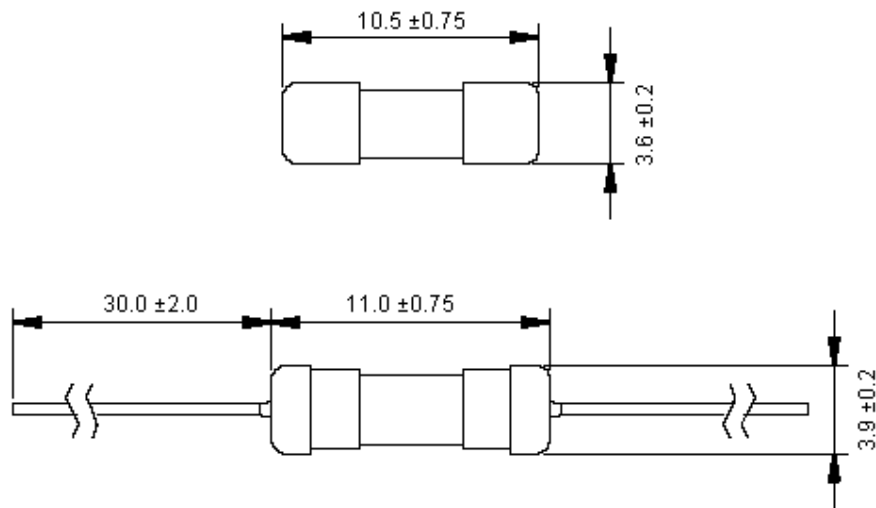

Dimensions : Millimetres

Electrical Characteristics

Rated Current	1 In	2 In
	Minimum	Maximum
50mA to 10A	4 hours	60 Second

Specifications:

Interrupting ratings : 50 amperes at 250V ac.
Operating temperature : -55°C to +125°C.

Options:

With heat shrink tubing (VM-1) over body.
PDP series available on tape and reel.

<http://www.farnell.com>
<http://www.newark.com>
<http://www.cpc.co.uk>



Micro Fuse

3.6 x 10mm - Time-Lag (T)



Physical Specification:

Materials

Glass body / Nickel brass caps

Lead wire:

Diameter Ø0.6mm 5A and less.

Diameter Ø0.8mm for rating above 6A to 7A.

Diameter Ø1.0mm for rating above 8A.

Specification Table

Description	Cartridge Catalogue Number	Axial Lead Catalogue Number	Ampere Rating (In)	Voltage Rating (V)	Nominal Resistance Cold Ohms	Nominal Melting I ² t A ² Second	Part Number
Fuse PDS 500mA	PDS .100	PDP .100	100mA	250	4.1550	0.0025	MCPDS .100
Fuse PDS 600mA	PDS .600	PDP .600	600mA		0.1550	0.5200	MCPDS .600
Fuse PDS 800mA	PDS .800	PDP .800	800mA		0.1420	0.8545	MCPDS .800
Fuse PDS 1A	PDS 001	PDP 001	1A		0.1100	1.2650	MCPDS 001
Fuse PDS 1.5A	PDS 1.50	PDP 1.50	1.5A		0.0710	3.5120	MCPDS 1.50
Fuse PDS 1.6A	PDS 1.60	PDP 1.60	1.6A		0.0620	3.4141	MCPDS 1.60
Fuse PDS 2A	PDS 002	PDP 002	2A		0.0504	6.0570	MCPDS 002
Fuse PDS 2.5A	PDS 2.50	PDP 2.50	2.5A		0.0353	8.8640	MCPDS 2.50
Fuse PDS 3A	PDS 003	PDP 003	3A		0.0237	18.108	MCPDS 003
Fuse PDS 4A	PDS 004	PDP 004	4A		0.0181	30.240	MCPDS 004
Fuse PDS 5A	PDS 005	PDP 005	5A		0.0144	54.626	MCPDS 005
Fuse PDS 6.3A	PDS 6.30	PDP 6.30	6.3A		-	-	MCPDS 6.30
Fuse PDS 7A	PDS 007	PDP 007	7A		0.0085	95.241	MCPDS 007
Fuse PDS 8A	PDS 008	PDP 008	8A		0.0078	118.236	MCPDS 008
Fuse PDS 10A	PDS 010	PDP 010	10A		0.0074	225.014	MCPDS 010

Disclaimer This data sheet and its contents (the "Information") belong to the Premier Farnell Group (the "Group") or are licensed to it. No licence is granted for the use of it other than for information purposes in connection with the products to which it relates. No licence of any intellectual property rights is granted. The Information is subject to change without notice and replaces all data sheets previously supplied. The Information supplied is believed to be accurate but the Group assumes no responsibility for its accuracy or completeness, any error in or omission from it or for any use made of it. Users of this data sheet should check for themselves the Information and the suitability of the products for their purpose and not make any assumptions based on information included or omitted. Liability for loss or damage resulting from any reliance on the Information or use of it (including liability resulting from negligence or where the Group was aware of the possibility of such loss or damage arising) is excluded. This will not operate to limit or restrict the Group's liability for death or personal injury resulting from its negligence. SPC Multicom is the registered trademark of the Group. © Premier Farnell plc 2011.

<http://www.farnell.com>
<http://www.newark.com>
<http://www.cpc.co.uk>

