

SP100 Pressure Sensor Series

The SP100 pressure sensors are calibrated and digitally compensated silicon piezoresistive sensors with SPI interface. SP100-15 is part of this series, and in addition to pressure it provides temperature and supply voltage measurements. Each sensor has a unique electronic sensor ID, and has a built in self diagnosis system. SP100-15 can easily be used in a broad range of applications and interfaces directly to a micro controller without the need of any additional components.

SP100 series of sensors has excellent media compatibility due to a patented bulk micromachined triple stack sensor die design, utilizing buried piezoresistive elements and backside media access to pressure diaphragm. With this design the internal connectors and piezoresistive elements of the pressure bridge are isolated from the measurement media. This isolation is of great importance in terms of stability and reliability of the sensor over a very long lifetime.

The SP100 sensor design has been proven in harsh environment applications during a period of more than 10 years, making these sensors ideal choices for demanding applications where simple solutions are needed to quickly implement reliable and accurate pressure measurements.

SP100-15 belongs to the higher pressure range of SP100 sensors.

SP100-15

Edition 2010-12-14
Published by
Sensoror Technologies AS
P.O. Box 196
N-3192 Horten
Norway
© Sensoror Technologies AS 2010.
All Rights Reserved.

Information furnished by Sensoror Technologies is believed to be accurate and reliable. However, no responsibility is assumed by Sensoror Technologies for its use, nor for any infringements of patents or other rights of third parties that may result from its use. Sensoror Technologies reserves the right to make changes without further notice to any products herein. Sensoror Technologies makes no warranty, representation or guarantee regarding the suitability of its products for any particular purpose, nor does Sensoror Technologies assume any liability arising out of the application or use of any product or circuit, and specifically disclaims any and all liability, including without limitation consequential or incidental damages. No license is granted by implication or otherwise under any patent or patent rights of Sensoror Technologies. Trademarks and registered trademarks are the property of their respective owners. Sensoror Technologies products are not intended for any application in which the failure of the Sensoror Technologies product could create a situation where personal injury or death may occur. Should Buyer purchase or use Sensoror Technologies products for any such unintended or unauthorized application, Buyer shall indemnify and hold Sensoror Technologies and its officers, employees, subsidiaries, affiliates, and distributors harmless against all claims, costs, damages, and expenses, and reasonable legal fees arising out of, directly or indirectly, any claim of personal injury or death associated with such unintended or unauthorized use, even if such claim alleges that Sensoror Technologies was negligent regarding the design or manufacture of the part.

Table of Contents

1	Product Description	- 4 -
1.1	Features	- 4 -
1.2	Overview.....	- 4 -
2	Measurement Performance	- 5 -
2.1	Pressure Measurement Performance	- 5 -
2.2	Temperature Measurement Performance	- 5 -
2.3	Supply Voltage Measurement Performance	- 6 -
3	Recommended Operating Conditions	- 6 -
4	Absolute Maximum Ratings	- 6 -
5	Wake-Up and Reset Outputs.....	- 7 -
6	Serial Interface.....	- 7 -
6.1	SPI Protocol.....	- 7 -
6.2	SPI Commands	- 8 -
6.3	SPI Timing Parameters	- 9 -
6.4	Status Byte	- 9 -
6.5	Temperature Byte.....	- 9 -
6.6	Pressure Byte.....	- 9 -
6.7	Supply Voltage Byte	- 9 -
7	Digital Output Characteristics	- 10 -
8	Power-On Reset	- 10 -
9	Current Consumption.....	- 10 -
9.1	Standby Current	- 10 -
9.2	Measurement Current	- 10 -
10	Error Handling and Recovery	- 11 -
10.1	PROM Data	- 11 -
10.2	PROM Reload	- 11 -
10.3	Shadow Register Protection.....	- 11 -
10.4	Low Supply Voltage.....	- 11 -
10.5	High Temperature	- 11 -
10.6	Overflow/Underflow	- 11 -
11	Mechanical Specifications	- 12 -
11.1	Physical Dimensions	- 12 -
11.2	Pin Configuration	- 13 -
11.3	Marking.....	- 13 -

1 Product Description

1.1 Features

- 0 to 1500kPa absolute pressure sensor
- Fully digitized and compensated over pressure and temperature
- -40 to 125degC temperature operating range
- SPI interface
- Sensor self diagnosis
- Unique electronic sensor IDs
- High reliability over long lifetime (10 years and above)
- 0.3 μ A standby current
- High media compatibility (automotive qualified)
- Additional temperature and supply voltage measurements
- Robust miniature surface mount package
- No external components required

1.2 Overview

SP100-15 is an integrated MEMS pressure sensor designed and qualified for air pressure measurements. The sensor has a digital interface designed for use in microcontroller applications. SP100-15 is housed in a 14 pin small outline package, and requires no external components.

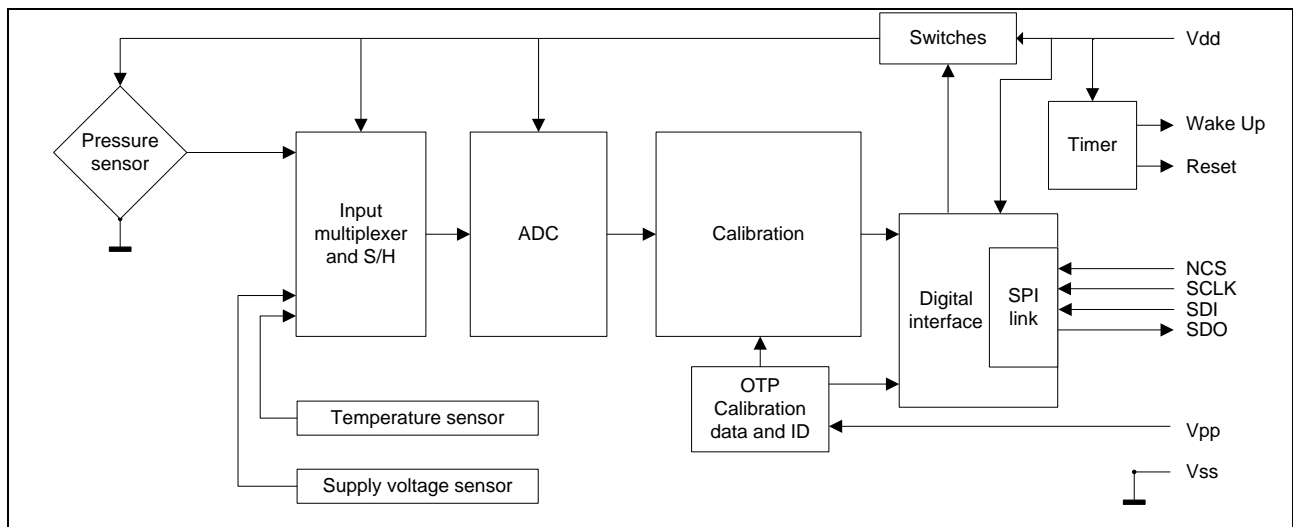

Figure 1.1 SP100-15 block diagram

2 Measurement Performance

The ADC of the sensor is an integrating charge balancing converter. Monotonic operation and no missing codes are guaranteed over the full operating range. All the following specification limits are to be understood as typical values unless otherwise is stated.

2.1 Pressure Measurement Performance

Parameter	Specification		Ambient conditions
	Unit	Typ	Pressure [kPa]
Resolution	kPa/lsb	2.97	
Accuracy	kPa	±17	0 to 1000
	kPa	±30	1000 to 1300
	kPa	±40	1300 to 1500
Pressure measurement time	ms	6 (max)	

2.2 Temperature Measurement Performance

Parameter	Specification		Ambient conditions
	Unit	Typ	Temperature [°C]
Resolution	°C/lsb	1	
Accuracy	°C	±2.4	0 to 50
	°C	±3.0	-40 to 100
	°C	±4.8	100 to 125
Pressure measurement time	ms	1.5 (max)	

The temperature read is known to have a deviation from actual temperature. A correction term is given by:

$$\Delta T_{corr} = 0.004 * T_{PRODUCT} + 0.0002 * T_{PRODUCT}^2$$

Where:

$T_{PRODUCT}$ is the temperature reported by the product

ΔT_{corr} is the correction term. See Figure 2.1.

ΔT_{corr} should be subtracted from the reported temperature to achieve the specified accuracy.

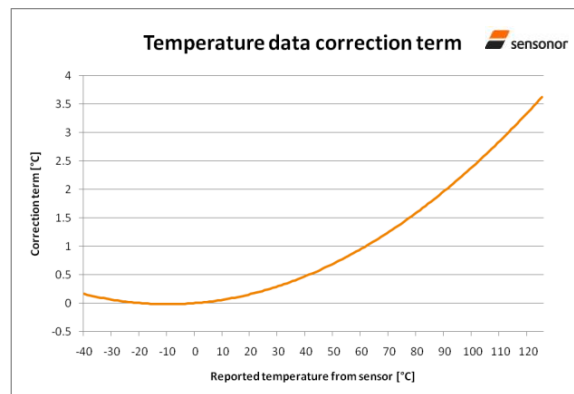

Figure 2.1 Temperature data correction term

2.3 Supply Voltage Measurement Performance

Parameter	Specification		Ambient conditions
	Unit	Typ	Supply voltage [V]
Input range ¹⁾	V	1.8 to 3.6	
Resolution	mV/lb	18.4	
Accuracy	mV	±60	2.1 to 3.6
Delay between measurement command and sampling	ms	3.5	
Delay between sampling and A/D conversion	ms	10	
Supply voltage measurement total time	ms	17 (max)	2.1 to 3.6

Note:

- 1) The sampling operates down to 1.8 V. The specification applies to A/D-conversion.

3 Recommended Operating Conditions

Description	Min	Typ	Max	Units
Temperature operating range	-40		125	°C
Supply voltage during measurement ¹⁾	2.1		3.6	V
Supply voltage between measurements	1.8		5.5	V
Input pressure ²⁾	0		1500	kPa

Notes:

- 2) This is the voltage range where measurement accuracy is specified.
 3) All pressure values given in this specification are absolute values.

4 Absolute Maximum Ratings

Description	Min	Typ	Max	Units
Input pressure			3300	kPa
Temperature ¹⁾	-40		+150	°C
Temperature transient ²⁾	-40		+175	°C
Storage temperature ³⁾	-40		+150	°C
Supply voltage	-0.3		6.0	V
Input voltage, any pin	-0.3		VDD + 0.3	V
Input current, any pin (transient)	-100		+100	mA
ESD protection (human body model) ⁴⁾	±2000V to any pin			
ESD protection (charge device model) ⁵⁾	±500V to any pin			

Notes:

- 1) The component will also withstand standard reflow soldering, accumulated time < 2.5 hours.
 2) Less than 3 min.
 3) Accumulated time at 150°C not to exceed 500hours to avoid permanent damage. Solder ability may be affected with less exposure.
 4) According to AEC-Q100-002/ JESD22-A114
 5) According to AEC-Q100-011/ JESD22-C101

Prolonged exposure to values between recommended operating conditions and absolute maximum ratings might affect the performance and reliability of the device.

5 Wake-Up and Reset Outputs

The product provides two outputs, which may be used to interrupt or reset a microcontroller. Each output provides a pulse at regular intervals. The “wake-up and reset” are active low outputs. The Wake Up period is programmable from 1 to 256 seconds, in 1 second intervals. The command to set this is found in the table of chapter 6.2.

Table 5.1 Wake-up and reset outputs

Parameter	Min	Typ	Max	Unit
Wake Up Width	0.13		2.5	ms
Reset period		51		min
Reset width	0.13		2.5	ms
Interval timing drift over temperature ¹⁾		0.6	1	%/°C
Interval timing drift over supply voltage ¹⁾		-15	-40	%/V

Notes:

- 1) The product has two oscillators: One low-power oscillator, which runs at about 2.5 kHz and is used for interval timing, and a 2 MHz oscillator used for measurements and data transmission. Due to its very low current consumption, the low-power oscillator is sensitive to temperature and supply voltage variation. To keep the interval lengths constant under different conditions, the low-power oscillator is compared to the 2 MHz oscillator during each measurement, and a correction is applied to the interval count. This operation is called an auto calibration. The stability of the interval depends on the change in temperature or supply voltage since the last measurement.

6 Serial Interface

The SPI interface is the communication protocol to the external microcontroller. This maximum serial clock frequency is 500 kHz.

The SPI consists of a shift register, a command latch and failure latches, and encoder/decoder logic.

6.1 SPI Protocol

When NCS is high, any signals at the *SCLK* and *SDI* pins are ignored, and *SDO* is forced into a high impedance state.

During the *NCS* high-to-low transition, the SPI response word is multiplexed from the latch(es) that was(were) defined by the last command present in the shift register. The *SCLK* pin must be low when *NCS* goes low.

At each clock rising edge after *NCS* has gone low, the response word is serially shifted out of the ASIC at the *SDO* pin, LSB first. At each clock falling edge after *NCS* has gone low, the new control word is serially shifted into the ASIC at the *SDI* pin, LSB first.

The command bits of the received SPI word are then decoded to determine the destination address for the data bits. After the 8th clock falling edge has occurred, the following *NCS* low-to-high transition causes the data bits stored in the ASIC SPI shift register to be transferred into the latch which address was decoded from the SPI shift register command bits.

If the number of clock pulses before *NCS* goes high is different from 0, 8 or 16, a digital filter prevents execution of the received command. Also to notice; A valid *NCS* pulse with 0 clock pulses will cause the previous command to be executed again.

A Failure Status Indicator (FSI) is a logical OR of all bits in the status register, except for bit 6. However, for SP100-15 the FSI indication should be ignored.

To validate P, T and V measurements for SP100-15 the Status register should be checked. This is done by executing the RSR command after each measurement and evaluating the content. The corresponding measurement result should be rejected if, and only if, the status register indicates an error. Status bits of interest for measurement validity are all except bit 5 and 6 (see more in chapter 6.4).

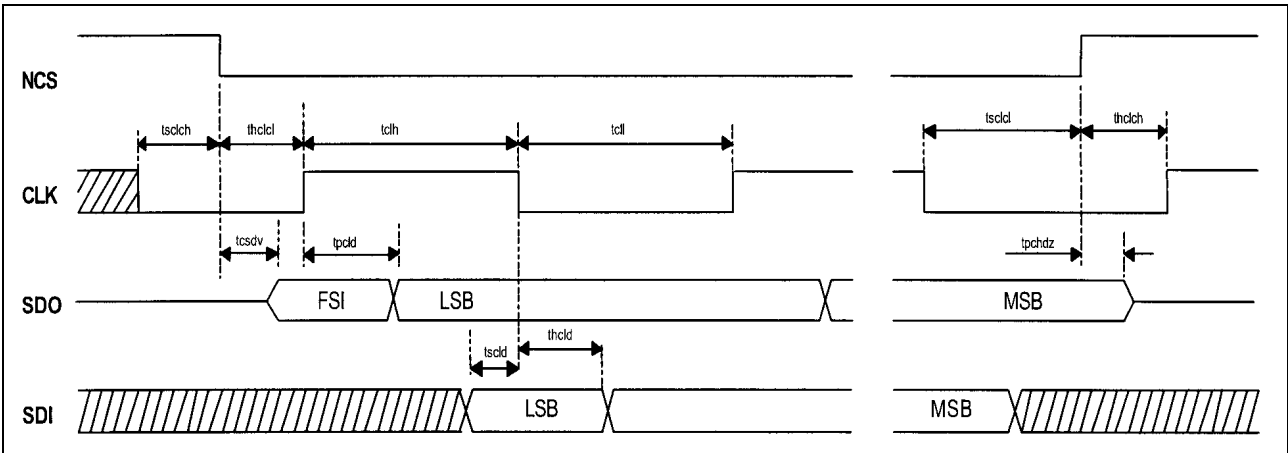

Table 6.1 SPI timing diagram

Control bytes and response bytes are 8 bits, the content of which depends upon the command given. When a control byte is shifted in, the response byte that is shifted out during the same transition time will be the response byte from the previous command: Shift in control byte « n », shift out response byte « n - 1 ». Therefore, each control/response pair requires two full 8-bit shift cycles to complete. The control bytes are described in chapter 6.2. Some control bytes require an additional data byte. For such command, the data byte must be transmitted first, before the command byte.

If an invalid SPI command is received, no action will be taken and the response word will be all zeros (00 hex).

6.2 SPI Commands

Command	Code	Address	Response	Description
MEASURE_P	0011 0001		Read back command code	Measure pressure
RCPDH	0010 1100		Compensated pressure data, high byte	Read compensated pressure data, high byte
RCPDL	0010 1101		Compensated pressure data, low byte	Read compensated pressure data, low byte
RRPDH	0000 1000		Raw pressure data, high byte	Read raw pressure data, high byte
RRPDL	0000 0100		Raw pressure data, low byte	Read raw pressure data, low byte
READIDH ₂₎	0011 1101		ID, high byte	Read ID, high byte
READIDM ₂₎	0011 1000		ID, mid byte	Read ID, mid byte
READIDL ₂₎	0011 0100		ID, low byte	Read ID, low byte
MEASURE_B	0010 0101		Read back command code	Measure battery voltage
RCBD	0010 1001		Compensated supply data	Read compensated supply data
MEASURE_T	1010 1101		Read back command code	Measure temperature
RCTMP	1011 0000		Compensated temperature data	Read compensated temperature
RSR	1011 0101		Common general Status register (see byte description below)	Read common general status register
READ ₁₎	1011 1000	A	One byte of shadow register	Read one byte of shadow register (OTP coefficients)
OTP_PWR ₁₎	1111 0110	A	Read back command code	Turn OTP power on/off
RADDR	1100 0001		Read register at applied address	Read applied address (test of SPI)
STANDBY	0000 0001		Last response repeated	Go in Stand-by mode and shift out the response from the previous measurement command
LDOTP	1011 1100		Read back command code	Reset of product: Load OTP content to shadow register
SETWK ₁₎	0010 1110	A	Read back command code	Set length of WAKEUP interval in address field (1 - 256 s). A=0x00 give 1s interval
GETWK	0010 1111		Programmed value of wakeup interval (0-255)	Read back length of wakeup interval

Notes:

- 1) These commands expects a parameter, address byte, in front
- 2) The three bytes of the ID (Identifier) code are programmed in the product PROM, giving ~16.8 million unique ID values

6.3 SPI Timing Parameters

SPI (Load capacitor at SDO = 300pF)		Min	Max	Unit
fSCLK	Max. allowed application frequency (50% duty cycle)		500	kHz
tSDO_trans	SDO transition speed, 20% to 80% (with 60pF load capacitor)	5	25	ns
tclh	Minimum time SCLK = HIGH	100		ns
tcll	Minimum time SCLK = LOW	100		ns
tpcd	Propagation delay (SCLK to data edge at SDO valid)		100	ns
tcsdv	NCS = LOW to data edge at SDO active		100	ns
tsclch	SCLK low before NCS low (setup time SCLK to NCS edge H/L)	100		ns
thclcl	SCLK edge L/H after NCS edge H/L	100		ns
tsclcl	SDI input setup time (SCLK edge H/L after SDI data valid)	20		ns
thclcl	SDI input hold time (SDI data hold after SCLK edge H/L)		20	ns
tsclcl	SCLK low before NCS high	150		ns
thclch	SCLK high after NCS high	150		ns
tpchdz	NCS edge L/H to SDO at high impedance		100	ns
tonNCS	NCS min. high time	60		µs
	Capacitance at SDI, SDO, SCLK, NCS		10	pF
tfNCS	NCS filter time (Pulses shorter than tfNCS will be ignored)	10	100	ns
	NCS pulse filter ¹⁾			

Note:

- 1) Digital filter for driver control register latch function. Output latch function is only enabled if positive NCS occurs after 8 CLK cycles (or a multiple of 8) since last negative NCS edge

6.4 Status Byte

- Bit 0: Overflow/underflow
- Bit 1: Parity error in PROM data
- Bit 2: Checksum error in shadow register
- Bit 3: PROM reload / Internal Reset
- Bit 4: Unspecified measurement accuracy due to low supply voltage
- Bit 5: Not in use
- Bit 6: Not in use
- Bit 7: Measurement in progress:
 - 0 = Measurement completed, data can be read
 - 1 = Measurement in progress, data not available

6.5 Temperature Byte

The value in the temperature byte is (T+50), where T is temperature in °C. The allowed range (for which the accuracy is specified) for this byte is 10-175, corresponding to temperatures from -40 to 125°C. Remark: the temperature byte may show values outside this range, which have an undefined accuracy.

6.6 Pressure Byte

The pressure (in kPa) is obtained by multiplying the value in the pressure byte by the given resolution in kPa/lb (see section 2.1).

6.7 Supply Voltage Byte

The supply voltage (in V) is obtained by multiplying the value in the supply byte by 0.0184, and adding 1.73.

7 Digital Output Characteristics

These characteristics are valid for VDD 2.7V to 3.6V, temperature -40 to 125°C, and load current less than 1 mA.

Table 7.1 Digital output characteristics

Description	Min	Typ	Max	Unit
Output logic low		0.1	0.2	V
Output logic high	VDD - 0.25	VDD - 0.13		V

8 Power-On Reset

To guarantee a power-on reset, VDD must be at 0V for a minimum of 1ms. This will cause a hardware reset, and start a 10ms timer. After the 10ms, a negative pulse on the RESET pin will be generated and the PROM will be read. If this is successful, the product will enter normal operation. If the PROM reading is not successful, error handling will be as described in section 10.

Table 8.1 Power-on reset specifications

Description	Min	Typ	Max	Unit
VDD level to initiate power-on reset			0	V
VDD level not to initiate power-on reset	1.0			V
VDD rise time (to 2.2V or higher)	0.1			µs
Power-on reset duration		22		ms
VDD required to complete power-on reset	2.2			V
Delay before power-on reset pulse	0.83		12.5	ms
Duration of power-on reset pulse	0.16		2.5	ms

9 Current Consumption

9.1 Standby Current

The standby current is the current drawn by the product when only the low-power oscillator and the interval counters are running.

9.2 Measurement Current

During measurement, various analog modules will be switched on and off as required, to minimize the total current consumption.

Table 9.1 Measurement current

Parameter	Comment	Typ	Max	Unit
Supply current in standby mode	25°C, 2.1 V	0.3	0.45	µA
	90°C, 2.1V	2	3	µA
	120°C, 2.1 V	11	16.5	µA
Supply current, all analog modules active	25°C, 2.1 V	2.1	2.9	mA
	90°C, 2.1 V	2.2	3.0	mA
	120°C, 2.1 V	2.2	3.1	mA
Supply current, digital activity incl. MCLK	25°C, 2.1 V	0.5	0.8	mA
	90°C, 2.1 V	0.5	0.8	mA
	120°C, 2.1 V	0.6	0.9	mA
Supply current in standby mode	25°C, 3V	0.4	0.6	µA
	90°C, 3 V	2.3	3.45	µA
	120°C, 3V	13	19.5	µA
Supply current, all analog modules active	25°C, 3V	2.7	3.5	mA
	90°C, 3V	2.8	3.7	mA
	120°C, 3V	2.8	3.8	mA
Supply current, digital activity incl. MCLK	25°C, 3V	0.6	1.0	mA
	90°C, 3V	0.6	1.1	mA
	120°C, 3V	0.7	1.2	mA

10 Error Handling and Recovery

10.1 PROM Data

The PROM contains calibration data and the identification code (ID). It is read at power-on reset, when its contents are copied to the shadow register. The PROM contains one parity bit. If a parity error occurs during reading of the PROM, the product will enter the PROM Reload state, as described below.

10.2 PROM Reload

In this state, the product will read the PROM contents again with 1 s intervals until a successful read is completed. The PROM reading can fail for two reasons:

- Parity error in PROM data
- Reading not allowed due to supply voltage below minimum for read operation

If command via SPI is activated while the product is in the PROM reload/reset state, the FSI will be set.

10.3 Shadow Register Protection

After copying the PROM contents to the shadow register, a 16 bit CRC is calculated using the CCITT polynomial. This checksum is stored with the data, and is verified for each measurement cycle. If an error is detected, the product will return a single byte with an error code, and then enter PROM Reload / Reset state.

10.4 Low Supply Voltage

A supply voltage below 2.1 V (nominal) has two consequences:

- Reading of the PROM is not allowed
- The measurement accuracy cannot be guaranteed

The product uses a separate circuit with an output signal called VMIN, to detect this condition. VMIN = 1 will occur if $VDD < 2.1 \pm 0.1V$.

If low supply voltage causes the information in the shadow register to be corrupted, the product will enter PROM reload state as described in section 10.2.

10.5 High Temperature

If high temperature causes the information in the shadow register to be corrupted, the SP100-15 will enter PROM reload state as described in section 10.2.

10.6 Overflow/Underflow

The overflow bit will be set by an over- or underflow in the ADC or compensation module. For temperature and supply measurements, ADC overflow will not saturate the compensated output value.

11 Mechanical Specifications

11.1 Physical Dimensions

SP100-15 is housed in a 14 pin SOIC package, easily handled by automatic production lines.

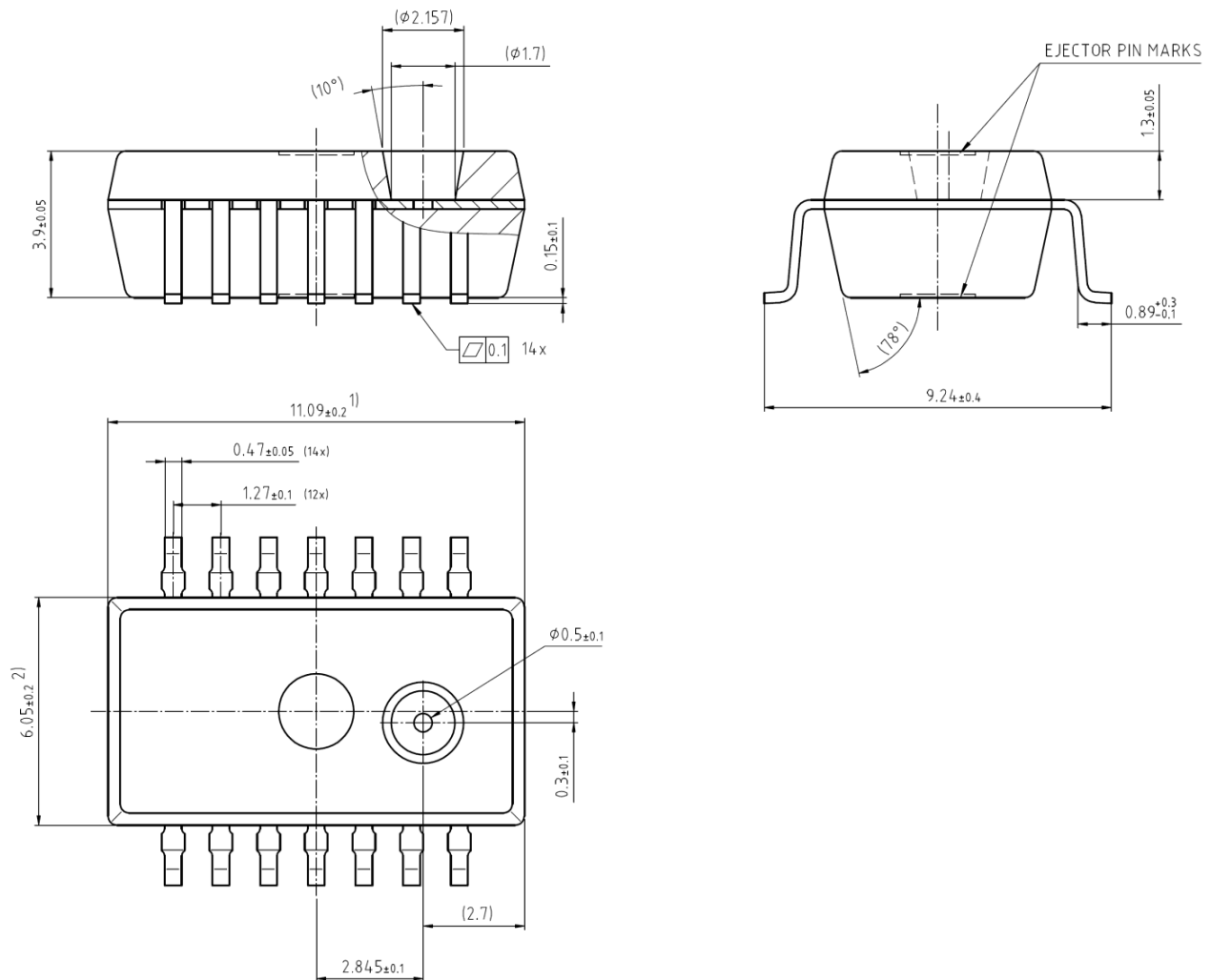

Notes:

- 1) Dimension does not include mold flash, protrusions or gate burrs. Mold flash, protrusions and gate burrs do not exceed 0.15mm (0.006 inch) per side.
- 2) Dimension does not include inter-lead flash or protrusions. Inter-lead flash and protrusions do not exceed 0.25mm (0.010 inch) per side.

11.2 Pin Configuration

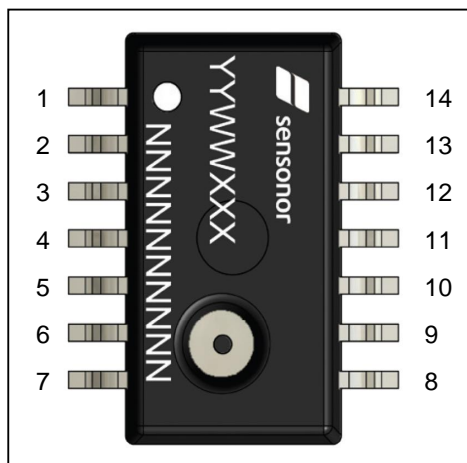

Figure 11.2 Pin configuration, top view

Table 11.1 Pin configuration description

PIN	NAME	FUNCTION	NOTE
1	WAKE UP	Wake up output	
2	RESET	Reset output	
3	TEST/GND	Test in fabrication	Connect to ground
4	VSS	Ground	Connect to ground
5	NC	Not connected	Connect to ground
6	DIG IN/GND	Digital input in fabrication	Connect to ground
7	VSS	Ground	Connect to ground
8	VSS	Ground	Connect to ground
9	VDD	Supply voltage	
10	VPP	Programmation voltage	Leave open
11	SDI	Serial data input	SPI interface pins
12	SCLK	Serial clock input	SPI interface pins
13	SDO	Serial data output	SPI interface pins
14	NCS	Negative chip select input	SPI interface pins

11.3 Marking

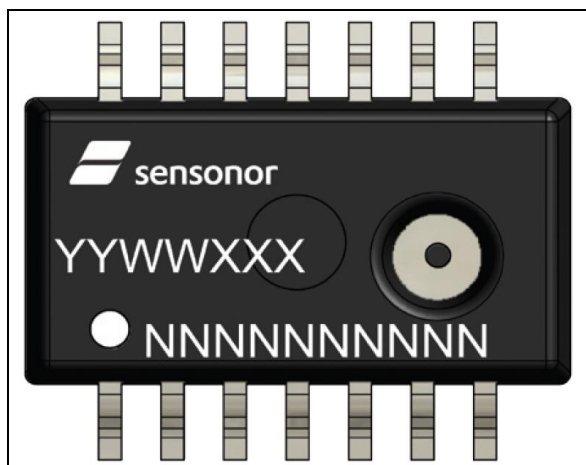

Figure 11.3 Marking of the SP100 pressure sensor series

The variables in Figure 11.3 have the following meaning:

YYWWXXX : Lot number
 NNNNNNNNNN: Product name
 O: Pin 1 marking