

350/420 Watts

MFA Series

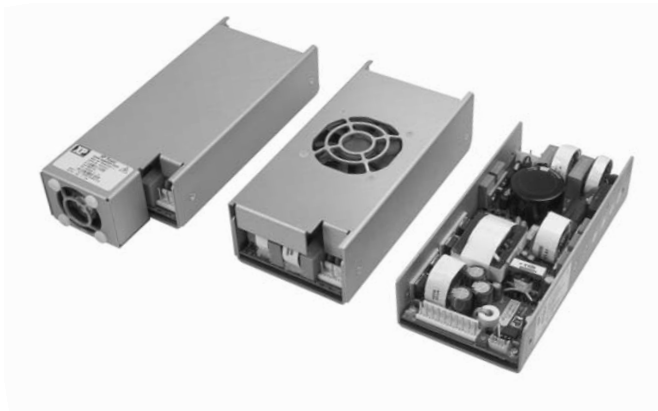

- U-Channel, Cover Fan & Hotswap Formats
- Power Density up to 12.8 W/in³
- Power Fail, DC OK & Active Current Share
- 5 V Standby & 12 V Fan Supply Outputs
- Screw Terminals Available
- 48 VDC Input Versions Available (DFA350)
- 3 Year Warranty

Specification

Input

Input Voltage	• 85-264 VAC (derate output power 10% below 90 VAC)
Input Frequency	• 47-63 Hz
Input Current	• Typically 3.6 A at 115 VAC & 1.8 A at 230 VAC
Inrush Current	• <60 A max at 230 VAC cold start at 25 °C
Power Factor	• >0.9
Earth Leakage Current	• Typically 1 mA at 230 VAC/50 Hz, 0.5 mA at 115 VAC/60 Hz
Input Protection	• T6.3 A/250 V fuse in line

Output

Output Voltage	• See tables
Output Voltage Trim	• ±10%
Initial Set Accuracy	• V1 ±1%, V2 ±5%, V3 ±3%
Minimum Load	• No minimum load required
Start Up Delay	• 2 s maximum, typically 1 s
Hold Up Time	• 16 ms minimum at 90 VAC full load
Drift	• ±0.2% after 20 min warm-up
Line Regulation	• V1 ±0.5%, V2 ±3.0%, V3 ±0.5%
Load Regulation	• V1 ±1.0%, V2 ±5.0%, V3 ±1.0%, 0-100% load V1 & V3, 10-100% load V2
Over/Undershoot	• <1% maximum
Transient Response	• <4% max deviation, with 50-75-50% load step. Recovery to within 1% <500 µs
Ripple & Noise	• V1 & V3: 1%, V2: 2% pk-pk, 20 MHz bandwidth
Overvoltage Protection	• 115-140% Vnom (on V1 only)
Overtemperature Protection	• Thermal sensor under PCB shuts unit down typically >+75 °C, restarts after cooling
Overload Protection	• 110-140%, I nom V1
Short Circuit Protection	• Continuous trip and restart (hiccup mode)
Temperature Coefficient	• 0.05%/°C
Remote Sense	• Compensates for 0.5 V total voltage drop
Remote On/Off	• Short circuit or TTL Low turns PSU off, can also be configured as enable
Current Share	• Up to 3 supplies can be connected in parallel, derate total output current to 90%

General

Efficiency	• Typically 86%
Isolation	• 3000 VAC Input to Output 1500 VAC Input to Ground 100 VDC Output to Ground
Switching Frequency	• PFC 62 kHz typical, Main converter 157 kHz, typical
Power Density	• 11.1 W/in ³ (MFA350), 12.8 W/in ³ (MFA420)
Signals	• Power Fail - open collector, transistor off for AC good, ≥5 ms warning of loss of output. DC OK - open collector, transistor off for DC good
MTBF	• 460 kHrs to MIL-HDBK-217F, notice 2, at +25 °C, GB, typical

Environmental

Operating Temperature	• Forced cooled: -10 °C to +70 °C, derate linearly from +50 °C at 2.5%/°C to +70 °C
Cooling	• >13 CFM forced airflow required for U Channel Versions, '-H', '-TF' & '-EF' versions have integral fan
Operating Humidity	• 5-95% RH
Storage Temperature	• -20 °C to +85 °C
Operating Altitude	• 3000 m
Shock	• 30 g pk, half sine, 6 axes
Vibration	• Single axis 10-500 Hz at 2 g x 10 sweeps

EMC & Safety

Emissions	• EN55022, class B conducted, class A radiated
Harmonic Currents	• EN61000-3-2 class A EN61000-3-2 class C for loads ≥20%
Voltage Flicker	• EN61000-3-3
Radiated Immunity	• EN61000-4-3, level 3 Perf Criteria A
EFT/Burst	• EN61000-4-4, level 3 Perf Criteria A
Surge	• EN61000-4-5, installation class 3 Perf Criteria A
Conducted Immunity	• EN61000-4-6, 10 V rms Perf Criteria A
Dips & Interruptions	• EN61000-4-11, 30% 10 ms, 60% 100 ms, 100% 5000 ms, Perf Criteria A, B, B
Safety Approvals	• CB Report, IEC60950-1, CSA22.2 No. 60950-1-05, UL60950-1, TUV EN60950-1/A11

Models and Ratings

MFA350/420 XP

Output Voltage V1	Output Current V1	Fan Output V2 ⁽³⁾	Standby Supply V3	Output Power 13 CFM Airflow	Model Number ⁽¹⁾
12 VDC	29.0 A	12 V/1 A	5 V/0.3 A	361 W	MFA350PS12 [†] ^
24 VDC	14.5 A	12 V/1 A	5 V/0.3 A	361 W	MFA350PS24 [†] ^
48 VDC	7.3 A	12 V/1 A	5 V/0.3 A	364 W	MFA350PS48 [†] ^
12 VDC	35.0 A	12 V/1 A	5 V/0.3 A	434 W	MFA420PS12
24 VDC	17.5 A	12 V/1 A	5 V/0.3 A	434 W	MFA420PS24
48 VDC	8.8 A	12 V/1 A	5 V/0.3 A	436 W	MFA420PS48

Notes

- Units supplied with Molex connections for J1 & J2 as standard. Add suffix '-S' to model number to replace with screw terminals. Add suffix '-TF' for covered version with top fan and suffix '-EF' for covered version with end fan. Example:- MFA420PS12-STF, 12 V unit fitted with screw terminals and top fan.
- Not available for -TF & -EF versions. [†] Available from Farnell & element14. See pages 284-290. [^] Available from Newark. See pages 291-296.

Mechanical Details

Top Fan (Suffix TF)

Weight: 1.7 lb (771 g) approx

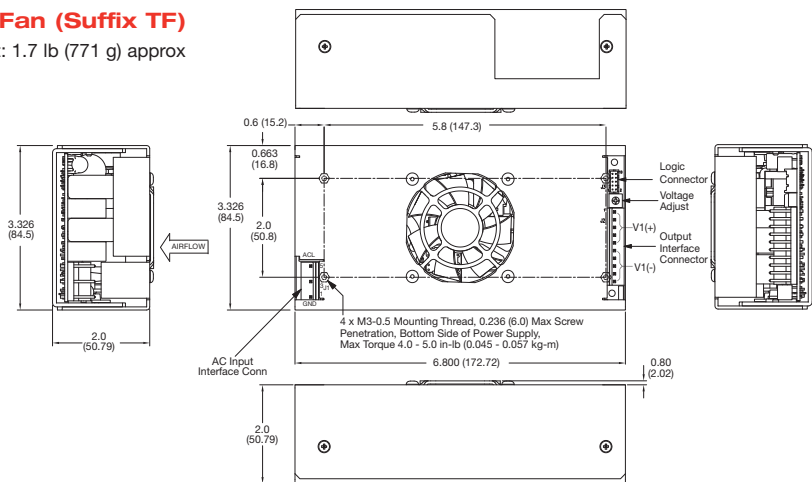

PIN CONNECTIONS AC INPUT J1 Molex 26-60-4050

PIN	FUNCTION
1	GND
3	Neutral
5	Line

Mating Parts: Molex, Housing 43061-0005
Contact 08-70-1030,
Option '-S' screw terminals
Phoenix Contact: MKDS 1/5-3.81 or similar
accepts 26-16 AWG wire (contacts 2 & 4 removed)
Max Torque 1.73 in-lb (0.02 kg-m)

PIN CONNECTIONS DC OUTPUT J2 Molex 26-60-4100

PIN	FUNCTION	PIN	FUNCTION
1	+V1	6	-V1
2	+V1	7	-V1
3	+V1	8	-V1
4	+V1	9	-V1
5	+V1	10	-V1

Mating Parts: Molex, Housing 43061-0010
Contact 08-70-1030,
Option '-S' screw terminals
2 x Phoenix Contact: MKDS 1/5-3.81 or similar
accepts 26-16 AWG wire
Max Torque 1.73 in-lb (0.02 kg-m)

U Channel

Weight: 1.35 lb (612 g) approx

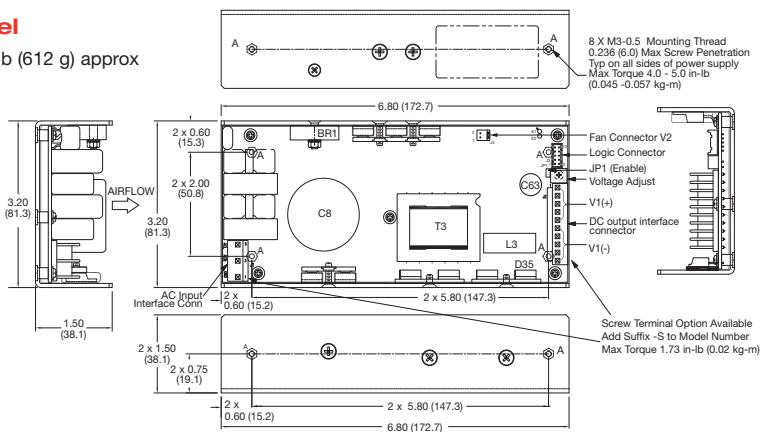

PIN CONNECTIONS FAN OUTPUT J4 Molex 22-04-1021

PIN	FUNCTION
1	+V2
2	-V2

Mating Parts: Molex, Housing 22-01-1024
Contact 08-70-0057

End Fan (Suffix EF)

Weight: 1.7 lb (771 g) approx

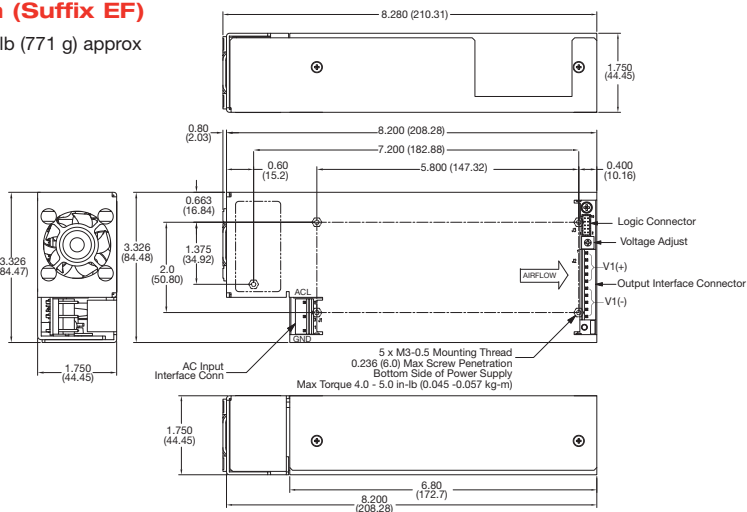

PIN CONNECTIONS LOGIC CONNECTOR J3 JST B10B-PHDSS (LF) (SN)

PIN	FUNCTION	PIN	FUNCTION
1	AC OK	6	+Sense
2	ROF (Inhibit/Enable)	7	-Sense
3	Current Share	8	Not Used
4	DC OK	9	5 V Standby V3
5	Not used	10	5 V Standby Return V3

Mating Parts: JST, Housing PHDR-10VS
Contact SPHD-001T-P0.5

Notes

- All dimensions in inches (mm).
- Tolerance: .xx=±0.02 (±0.50); .xxx=±0.01 (±0.25)



THE EXPERTS IN POWER

Models and Ratings

Output Voltage V1	Output Current	Standby Supply V3	Output Power	Model Number
12.0 VDC	29.0 A	5 V/0.3 A	350 W	MFA350PS12-H
24.0 VDC	14.5 A	5 V/0.3 A	350 W	MFA350PS24-H
48.0 VDC	7.3 A	5 V/0.3 A	352 W	MFA350PS48-H
12.0 VDC	35.0 A	5 V/0.3 A	434 W	MFA420PS12-H
24.0 VDC	17.5 A	5 V/0.3 A	434 W	MFA420PS24-H
48.0 VDC	8.8 A	5 V/0.3 A	436 W	MFA420PS48-H

Mechanical Details

-H Hotswap

Pin Connections

PIN CON. OUTPUT CON. FCI 51732-035-LF	
A1	+Sense
A2	Not Used
A3	DC OK
B1	-Sense
B2	Not Used
B3	AC OK
C1	Current Share
C2	Not Used
C3	5 V Standby V3
D1	Not Used
D2	ROF (Inhibit/Enable)
D3	5 V Standby Return V3
P1	-V1
P2	-V1
P3	+V1
P4	+V1

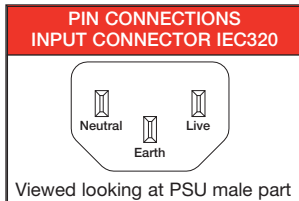
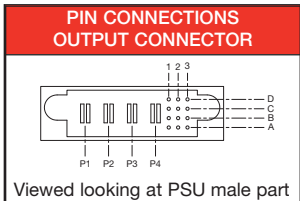
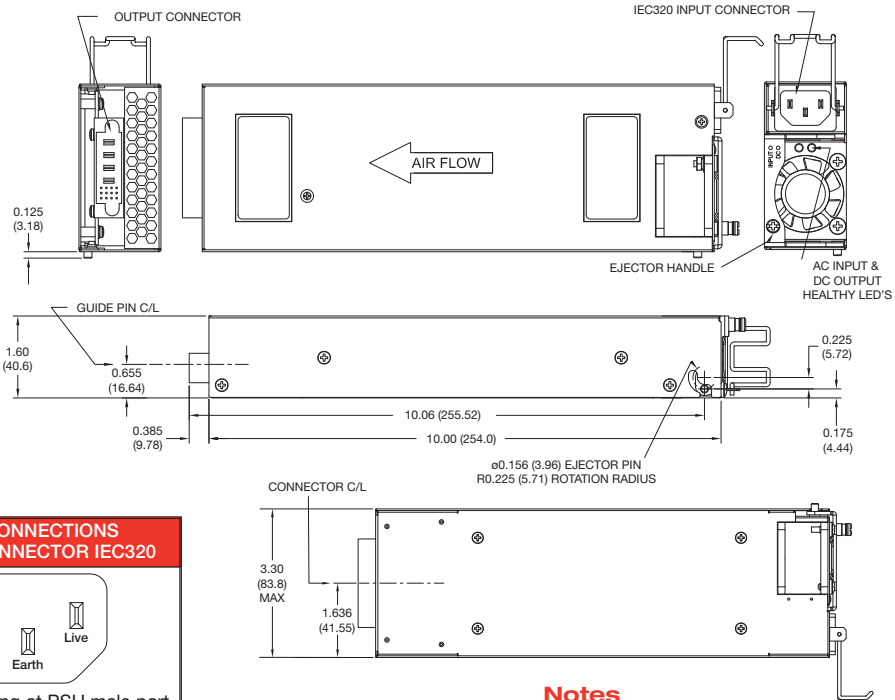

Notes

1. All dimensions in inches (mm).
2. Weight: 2.65 lb (1202 g) approx
3. Tolerance: .xx=±0.02 (±0.50); .xxx=±0.01 (±0.25)

Mating parts: FCI 51762-10401200AA-LF

Signals MFA350, MFA350-H, MFA420 & MFA420-H

AC OK/Power Fail

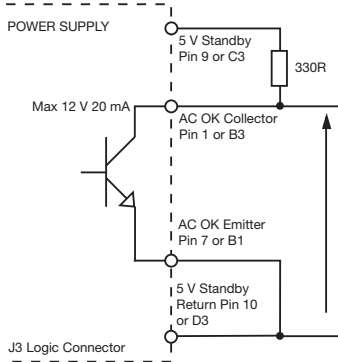

Transistor On (<0.8 V): AC NOT OK
Transistor Off (>4.5 V): AC OK

DC OK

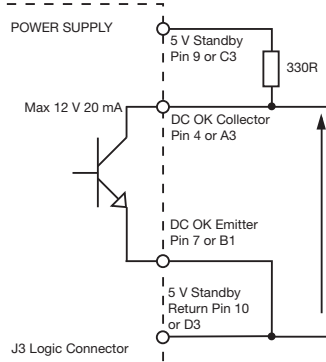

Transistor On (<0.8 V): DC NOT OK
Transistor Off (>4.5 V): DC OK

Remote On/Off (Inhibit/Enable)

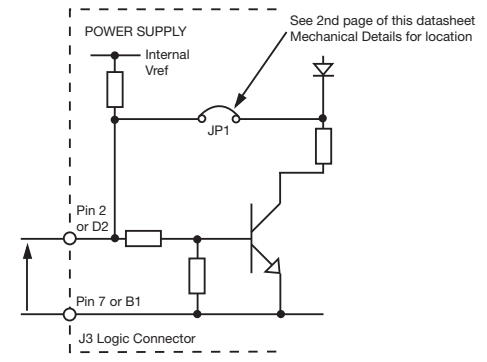

Jumper (JP1) fitted (standard)
Open or TTL high=PSU On
Short circuit or TTL Low=PSU Off

Jumper (JP1) removed
Open or TTL high=PSU Off
Short circuit or TTL Low=PSU On

Thermal Considerations (U Channel)

In order to ensure safe operation of the PSU in the end-use equipment, the temperature of the components listed in the table below must not be exceeded. See mechanical details for component locations. The temperature should be monitored using K type thermocouples placed on the hottest part of the component (out of any direct air flow). See longform datasheet for further information of service life.

MFA Temperature Measurements (Ambient ≤50 ° C)	
Component	Max Temperature ° C
T3	90 °C
BR1	105 °C
D35	85 °C
L3	90 °C
C8	105 °C
C63	105 °C

DFA Temperature Measurements (Ambient ≤50 ° C)	
Component	Max Temperature ° C
L1	90 °C
Q1	105 °C
HS1	85 °C
C25	75 °C
Q2	105 °C

Models and Ratings

Input Voltage	Input Current	UVLO	Output Voltage V1	Output Current V1	Fan Output V2	Standby Supply V3	Output Power 20 CFM Airflow	Model Number
48 VDC (36-75 VDC)	9.2 A typical 12.5 A max	32-36 VDC	12.0 VDC	29.0 A	12 V/1 A	5 V/1 A	365 W	DFA35048S12
			24.0 VDC	14.5 A	12 V/1 A	5 V/1 A	365 W	DFA35048S24
			12.0 VDC	29.0 A		5 V/1 A	365 W	DFA35048S12-H
			24.0 VDC	14.5 A		5 V/1 A	365 W	DFA35048S24-H

For all models the input reverse voltage protection is continuous with automatic recovery

Mechanical Details

U Channel

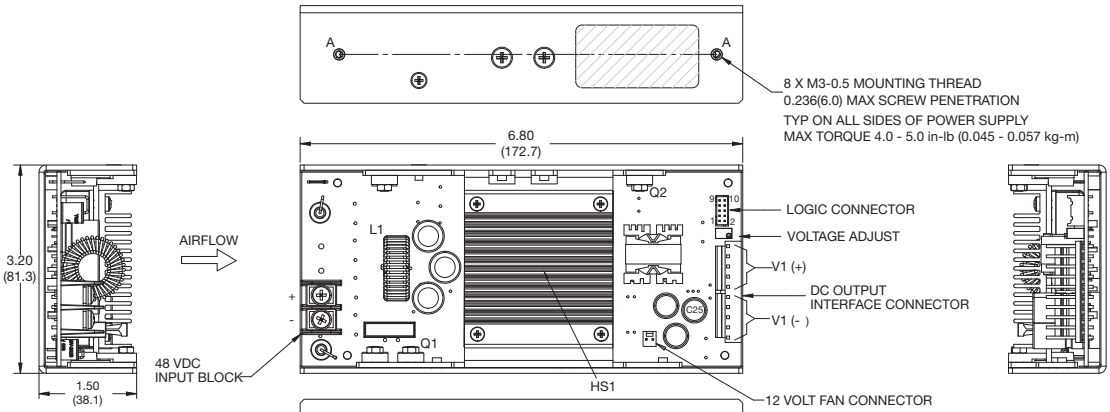

Logic Connector	
Pin	Function
1	DC IN OK
2	Inhibit / Enable
3	Not used
4	DC OK
5	Not used
6	+Sense
7	-Sense
8	Not used
9	5 V Standby
10	5 V Standby Return

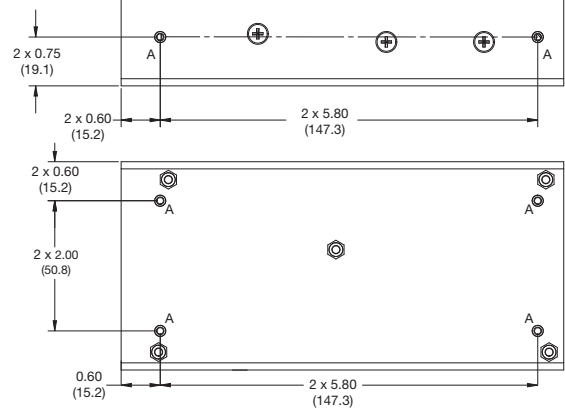

Logic Connector: JST PN B10B-PHDS(LF)(SN)
Mating Plug: JST PN PHDR-10VS
Contact, 26-22 AWG: JST PN SPHD-001T-P0.5

Notes

- All dimensions in inches (mm).
- Weight: U Channel 1.2 lb (544 g) approx,
-H Hotswap 2.5 lbs (1133 g) approx
- Tolerance: .xx=±0.02 (±0.50); .xxx=±0.01 (±0.25)

-H Hotswap

PIN CON. OUTPUT CON. FCI 51732-035-LF	
A1	+Sense
A2	Not Used
A3	DC OK
B1	-Sense
B2	Not Used
B3	DC IN OK
C1	Not used
C2	Not Used
C3	5 V Standby V3
D1	Not Used
D2	ROF (Inhibit/Enable)
D3	5 V Standby Return V3
P1	-V1
P2	-V1
P3	+V1
P4	+V1

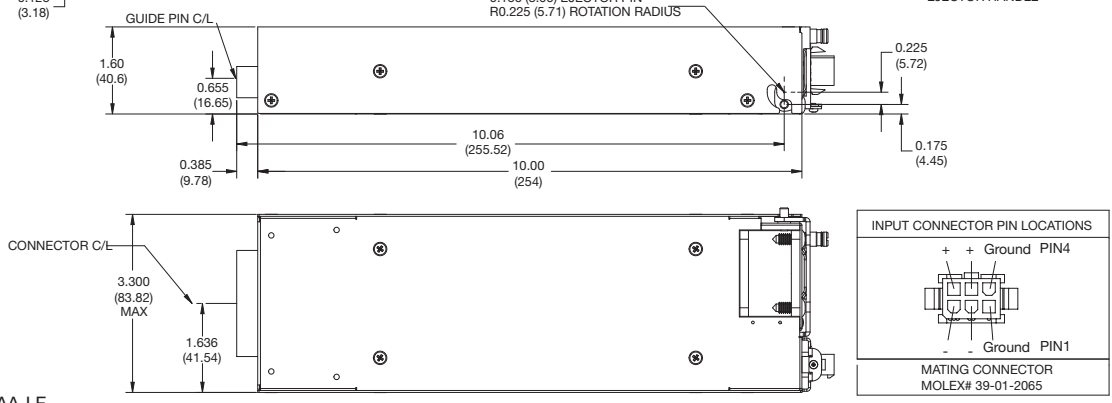
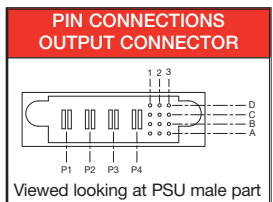
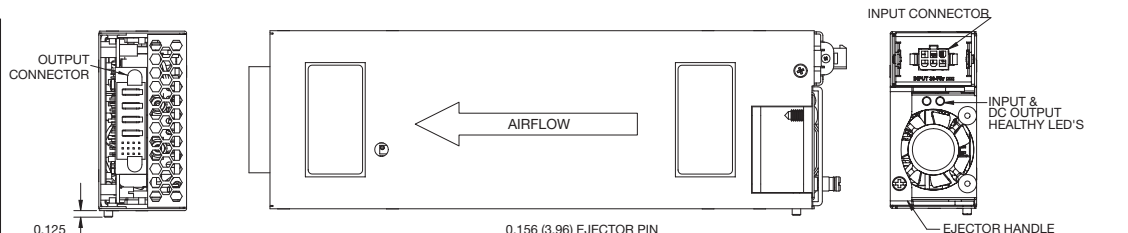

Mating parts: FCI 51762-10401200AA-LF

