



Typical unit

FEATURES

- Standard quarter-brick package/pinout
- Outputs from 1.2 to 48V up to 125W
- Low profile 0.42" height
- 24 and 48Vdc nominal inputs
- Fully isolated, 2250Vdc (BASIC) insulation
- Designed for RoHS compliance
- Output overvoltage/short-circuit protected
- On/Off control, trim and sense functions
- High efficiency to 94%
- Protected against temp. and voltage limits
- UL/IEC/EN60950 safety approvals
- Qual/HALT/EMI tested

DESCRIPTION

For efficient, fully isolated DC power in the smallest space, DATEL's UVQ series quarter bricks offer output voltages from 1.2 to 48 Volts with currents up to 40 Amps. UVQ's operate over a wide temperature range (up to +70°C at 200 lfm airflow) at full-rated power. The optional mounting baseplate extends this to all practical temperature ranges at full power.

UVQ's achieve these impressive specifications while delivering excellent electrical performance. Overall noise is 35mVp-p (3.3V models) with fast step response (down to 50µsec). These convert-

ORDERING GUIDE SUMMARY				
Model ^①	V _{OUT} Range ^①	I _{OUT} Range ^①	V _{IN} Range	Efficiency
All Models	1.2V to 48V	2.5A to 40A	18-36V or 36-75V	Up to 94%, model dependent

INPUT CHARACTERISTICS		
Parameter	Typ. @ 25°C, full load	Notes
Voltage Range	18-36 or 36-75 Volts	24V or 48V nominal
Current, full power	Up to 40 Amps	Model dependent
Isolation	2kVdc to 2250V	Model dependent
Remote On/Off Control	Switch or FET control	Positive or negative logic

OUTPUT CHARACTERISTICS		
Parameter	Typ. @ 25°C, full load	Notes
Voltage	1.2 to 48 Volts ±10%	Trimmable
Current	2.5 to 40 Amps fullscale	No minimum load
Accuracy	Down to 1% of V _{NOM}	Most models
Ripple & Noise (to 20MHz)	Down to 35mVp-p	Model dependent
Line and Load Regulation	Down to ±0.125%/±0.25%	Model dependent
Overcurrent Protection	150% of I _{OUT} max.	With hiccup auto-restart
Overtemperature Protection	+125°C	
Efficiency (minimum)	See Performance Specifications	

GENERAL SPECIFICATIONS		
Parameter	Typ. @ 25°C, full load	Notes
Dynamic Load Response	Down to 50µsec	Model dependent
Operating Temperature Range	-40 to +110°C	With baseplate, see derating curve
Safety	UL/IEC/EN 60950	And CSA C22.2-No.234

MECHANICAL CHARACTERISTICS	
With baseplate	1.45 x 2.30 x 0.5 inches (36.83 x 58.42 x 12.7 mm)
Without baseplate	1.45 x 2.30 x 0.42 inches (36.83 x 58.42 x 10.67 mm)

^① See Performance Specifications, page 2

ers offer high stability even with no load and tight output regulation. The unit is fully protected against input over and undervoltage, output overcurrent and short circuit. An on-board temperature sensor shuts down the converter if thermal limits are reached. Protection uses the "hiccup" (auto restart) method.

A convenient remote On/Off control input operates by external digital logic, relay or transistor input. To compensate for longer wiring and to retain output voltage accuracy at the load, UVQ's include a Sense input to dynamically correct for ohmic

losses. A trim input may be connected to a user's adjustment potentiometer or trim resistors for output voltage calibration closer than the standard accuracy.

UVQ's include industry-standard safety certifications and BASIC I/O insulation provides 2250 Volt input/output isolation. Radiation emission testing is performed to widely-accepted EMC standards. Contact DATEL for details on HALT qualification testing. The UVQ's may be considered as higher performance replacements for some DATEL USQ models.



PERFORMANCE SPECIFICATIONS AND ORDERING GUIDE ^①													
Model	Output						Input				Efficiency		Package (Case/ Pinout)
	V _{OUT} (Volts)	I _{OUT} (Amps)	R/N (mVp-p)		Regulation (Max.)		V _{IN} Nom. (Volts)	Range (Volts)	I _{IN} , No load (mA)	I _{IN} , Full load (Amps)	Min.	Typ.	
			Typ.	Max.	Line	Load							
UVQ-1.2/40-D48	1.2	40	TBD	TBD	±0.125%	±0.25%	48	36-75	TBD	TBD	TBD	TBD	C59,P32
UVQ-1.5/40-D24	1.5	40	35	60	±0.25%	±0.25%	24	18-36	40	2.84	86%	88%	C59,P32
UVQ-1.5/40-D48	1.5	40	TBD	TBD	±0.125%	±0.25%	48	36-75	TBD	TBD	TBD	TBD	C59,P32
UVQ-1.8/40-D48	1.8	40	TBD	TBD	±0.125%	±0.25%	48	36-75	TBD	TBD	TBD	TBD	C59,P32
UVQ-2.5/35-D24	2.5	35	35	60	±0.125%	±0.25%	24	18-36	100	14.14	86	88	C59,P32
UVQ-2.5/40-D48	2.5	40	35	55	±0.125%	±0.25%	48	36-75	30	1.72	89.5%	91%	C59,P32
UVQ-3.3/30-D24	3.3	30 ^③	35	65	±0.125%	±0.25%	24	18-36	180	4.63	87	89	C59,P32
UVQ-3.3/35-D48	3.3	35	35	55	±0.125%	±0.25%	48	36-75	30	2.24	90.5%	92%	C59,P32
UVQ-5/20-D24	5	20 ^④	50	75	±0.125%	±0.25%	24	19.5-36 ^②	120	4.63	88%	90%	C59,P32
UVQ-5/20-D48	5	20	45	75	±0.15%	±0.15%	48	36-75	80	2.34	86.5%	89%	C59,P32
UVQ-12/8-D24	12	8	95	130	±0.25%	±0.25%	24	18-36	120	4.44	89%	90%	C59,P32
UVQ-12/10-D48	12	10	110	160	±0.125%	±0.25%	48	36-75	45	2.69	91%	93%	C59,P32
UVQ-15/7-D24	15	7	85	150	±0.125%	±0.25%	24	18-36	45	4.7	91%	93%	C59,P32
UVQ-15/7-D48	15	7	120	150	±0.125%	±0.25%	48	36-75	45	2.33	92%	94%	C59,P32
UVQ-18/5.6-D24	18	5.6	125	185	±0.125%	±0.1%	24	18-36	130	4.67	88%	90%	C59,P32
UVQ-18/6-D48	18	6	125	185	±0.125%	±0.25%	48	36-75	45	2.42	92%	93%	C59,P32
UVQ-24/4.5-D24	24	4.5	125	TBD	±0.125%	±0.25%	24	18-36	45	4.79	93%	94%	C59,P32
UVQ-24/4.5-D48	24	4.5	120	TBD	±0.125%	±0.25%	48	36-75	45	2.39	93%	94%	C59,P32
UVQ-48/2.5-D48	48	2.5	100	125	±0.125%	±0.2%	48	36-75	30	2.66	90.5%	91.5%	C59,P32

① All models are tested and specified with 200 lfm airflow, external 1 and 10µF parallel ceramic/tantalum output capacitors. Input capacitance varies according to model type. These capacitors are necessary to accommodate our test equipment and may not be required to achieve specified performance in your applications. All models are stable and regulate within spec under no-load conditions.

Specifications are +25°C, V_{IN} = nominal, V_{OUT} = nominal, full load.

- ② I_{OUT} = 14 Amps maximum with V_{IN} = 18-36 Volts.
- ③ Minimum output current is 3 Amps.
- ④ Maximum output current is 14 Amps with V_{IN} = 18 to 19.5V.

PART NUMBER STRUCTURE

U VQ - 3.3 / 20 - D48 N B 9 LX - C

Output Configuration
U = Unipolar/Single

Quarter-Brick Package

Nominal Output Voltage
1.2 to 48 Volts

Maximum Rated Output
Current in Amps

Input Voltage Range:
D24 = 18-36 Volts (24V nominal)
D48 = 36-75 Volts (48V nominal)

RoHS-6 compliant *

Alternate Pin Length:
L1 = 0.110 (2.79mm)
L2 = 0.145 (3.68mm)
Blank = Standard pin length

Baseplate Pin 9, see Mechanical Drawings: (special order)
9 = Pin 9 installed (12V_{OUT} or higher models)
Blank = No pin 9

B = Baseplate installed
Blank = No baseplate

Remote On/Off Control Polarity:
Add "P" for positive polarity
Add "N" for negative polarity

*** Note:**
Not all model number combinations are available. Contact C&D Technologies (DATEL).

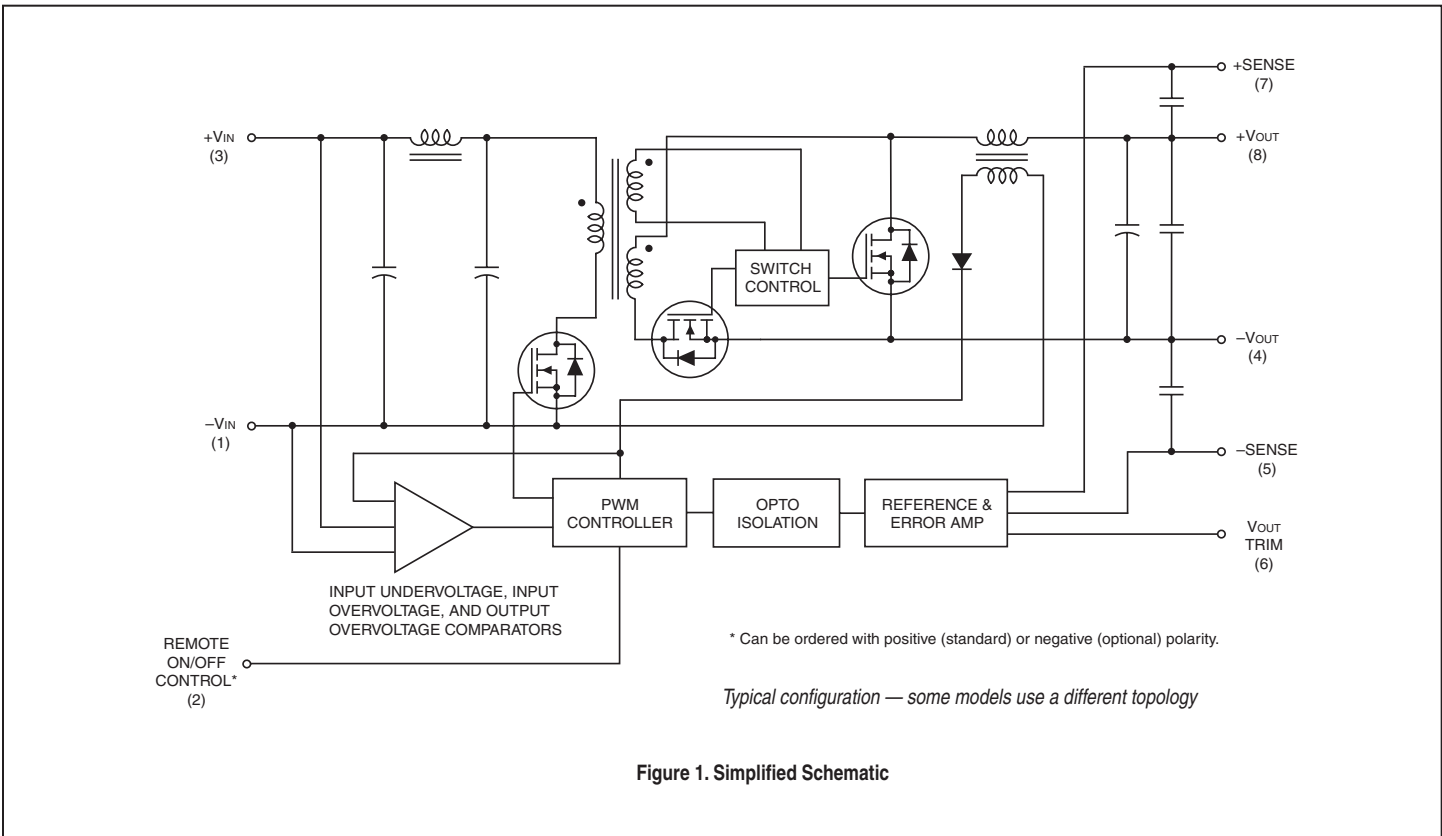

Low-Profile, Isolated Quarter-Brick 2.5-40 Amp DC/DC Converters

Performance/Functional Specifications 24V Models Typical @ $T_A = +25^\circ\text{C}$ under nominal line voltage, nominal output voltage, natural air convection, external caps and full-load conditions, unless noted. (1)

	UVQ-1.5/40-D24	UVQ-2.5/35-D24	UVQ-3.3/30-D24	UVQ-5/20-D24	UVQ-12/8-D24	UVQ-15/7-D24	UVQ-18/5.6-D24	UVQ-24/4.5-D24
INPUT								
See ordering guide								
Input Voltage Range	17.5 Volts	17.9 Volts	17.9 Volts	17.9 Volts	18 Volts	18 Volts	18 Volts	17 Volts
Start-up Threshold, min.	16 Volts	16 Volts	16 Volts	16 Volts	15.5 Volts	16 Volts	16.25 Volts	16 Volts
Undervoltage Shutdown (14)	none	none	none	none	39 Volts	39 Volts	none	none
Overvoltage Shutdown (11)	1.5mA _{p-p}	10mA _{p-p}	10mA _{p-p}	10mA _{p-p}	8mA _{p-p}	5mA _{p-p}	25mA _{p-p}	10mA _{p-p}
Reflected (back) Ripple Current (2)								
INPUT CURRENT								
See ordering guide								
Full load conditions								
Inrush transient	0.5A ² sec	0.5A ² sec	0.05A ² sec	0.5A ² sec	0.1A ² sec	1A ² sec	1A ² sec	0.05A ² sec
Output short circuit	40mA	50mA	50mA	50mA	10mA	320mA	50mA	50mA
No load	40mA	100mA	180mA	120mA	90mA	103mA	140mA	45mA
Low line (V_{in} = min.)	3.85 Amps	5.52 Amps	6.18 Amps	5.64 Amps	5.93 Amps	6.45 Amps	6.29 Amps	6.38 Amps
Standby mode (Off, UV, OT shutdown)	1mA	2mA	1mA	2mA	4mA	2.9mA	1mA	1mA
Internal Input Filter Type	L-C	L-C	L-C	L-C	L-C	L-C	Pi-type	Pi-type
Reverse Polarity Protection								
See notes								
Remote On/Off Control (5)								
Positive logic, "P" suffix (specifications are max.)	OFF = Gnd. to +0.8V ON = open or 3.5V to 15V	OFF = Gnd. to +0.8V ON = open or 3.5V to 15V	OFF = Gnd. to +0.8V ON = open or 5V to +V _{in}	OFF = Gnd. to +0.8V ON = open or 3.5V to 15V	OFF = Gnd. to +0.8V ON = open or 5V to +V _{in}	OFF = Gnd. to +0.8V ON = open or 3.5V to 13.5V	OFF = Gnd. to +0.8V ON = open or 5V to +V _{in}	OFF = Gnd. to +0.8V ON = open or 3.5V to 13.5V
Negative logic, "N" suffix (specifications are max.)	OFF = open or 3.5V to +V _{in} ON = Gnd. to +0.8V	OFF = open or 5V to +V _{in} ON = Gnd. to +0.8V	OFF = open or +5V to +V _{in} ON = Gnd. to +0.8V	OFF = open or +5V to +V _{in} ON = Gnd. to +0.8V	OFF = open or 5V to +V _{in} ON = Gnd. to +0.8V	OFF = open or 3.5V-13.5V ON = Gnd. to +1V	OFF = open or 5V to +V _{in} ON = Gnd. to +1V	OFF = open or 3.5V to 13.5V ON = Gnd. to +1V
Current	0.7mA	1mA	8mA	1mA	1.5mA	1mA	1.5mA	1mA

Low-Profile, Isolated Quarter-Brick 2.5-40 Amp DC/DC Converters

Performance/Functional Specifications 24V Models Typical @ $T_A = +25^\circ\text{C}$ under nominal line voltage, nominal output voltage, natural air convection, external caps and full-load conditions, unless noted. (1)

	UVQ-1.5/40-D24	UVQ-2.5/35-D24	UVQ-3.3/30-D24	UVQ-5/20-D24	UVQ-12/8-D24	UVQ-15/7-D24	UVQ-18/5.6-D24	UVQ-24/4.5-D24
OUTPUT								
Voltage Output Range	See ordering guide							
Voltage Output Accuracy	$\pm 1.5\%$ of V_{NOM} (50% load)	$\pm 1.5\%$ of V_{NOM} (50% load)	$\pm 1\%$ of V_{NOM} (50% load)	$\pm 1.5\%$ of V_{NOM} (50% load)	$\pm 1.25\%$ of V_{NOM} (50% load)	$\pm 1\%$ of V_{NOM} (50% load)	$\pm 1\%$ of V_{NOM} (50% load)	$\pm 1\%$ of V_{NOM} (50% load)
Adjustment Range (12)	-20 to $+10\%$ of V_{NOM}							
Temperature Coefficient	$\pm 0.02\%$ of V_{out} range/ $^\circ\text{C}$							
Minimum Loading	No minimum load	3 Amps	3 Amps	No minimum load	No minimum load			
Remote Sense Compensation	$+10\%$							
Ripple/Noise	See ordering guide (8)							
Line/Load Regulation	See ordering guide (10)							
Efficiency	See ordering guide							
Maximum Capacitive Loading Low ESR $< 0.02\Omega$ max., resistive load	10,000 μF	10,000 μF	10,000 μF	6000 μF	4700 μF	4700 μF	4700 μF	4700 μF
Isolation Voltage	See ordering guide							
Input to Output	2000 Volts min.	2000 Volts min.	2000 Volts min.	2000 Volts min.	2000 Volts min.	2000 Volts min.	2000 Volts min.	2000 Volts min.
Input to baseplate	1500 Volts min.							
Baseplate to output	1500 Volts min.	1500 Volts min.	1500 Volts min.	1000 Volts min.	1500 Volts min.	1500 Volts min.	1500 Volts min.	1500 Volts min.
Isolation Resistance	100M Ω							
Isolation Capacitance	1500pF	1500pF	1500pF	1500pF	1000pF	2000pF	50pF	50pF
Isolation Safety Rating	Basic insulation							
Current Limit Inception (98% of V_{out} , after warmup)	45 Amps	42 Amps	36 Amps	25 Amps	9.5 Amps	9.5 Amps	7 Amps	24 Amps
Short circuit protection method (6)	Current limiting, hiccup autorestart. Remove overload for recovery.							
Short circuit current	3.6 Amps	3 Amps	3 Amps	3 Amps	1.5 Amps	150 mA	3 Amps	5 Amps
Short circuit duration	Continuous, output shorted to ground (no damage)							
Overvoltage protection via magnetic feedback	2.3 Volts	3 Volts max.	3 Volts max.	3 Volts max.	14.4 Volts max.	3.96 Volts max.	22 Volts max.	3.96 Volts max.

Low-Profile, Isolated Quarter-Brick 2.5-40 Amp DC/DC Converters

Performance/Functional Specifications 24V Models Typical @ $T_A = +25^\circ\text{C}$ under nominal line voltage, nominal output voltage, natural air convection, external caps and full-load conditions, unless noted. (1)

	UVQ-1.5/40-D24	UVQ-2.5/35-D24	UVQ-3.3/30-D24	UVQ-12/8-D24	UVQ-5/20-D24	UVQ-15/7-D24	UVQ-18/5.6-D24	UVQ-24/4.5-D24
DYNAMIC CHARACTERISTICS								
Dynamic load response	100µsec to $\pm 1\%$ of final value (50-75-50% load step)	150µsec to $\pm 1\%$ of final value (50-75-50% load step)	150µsec to $\pm 1\%$ of final value (50-75-50% load step)	50µsec to $\pm 1\%$ of final value (50-75-50% load step)	150µsec to $\pm 1\%$ of final value (50-75-50% load step)	50µsec to $\pm 1\%$ of final value (50-75-50% load step)	50µsec to $\pm 1\%$ of final value (50-75-50% load step)	50µsec to $\pm 1\%$ of final value (50-75-50% load step)
Start-up time V_{IN} to V_{OUT} regulated Remote On/Off to V_{OUT} regulated	90msec 90msec	50msec 50msec	50msec max. 50msec max.	40msec max. 30msec max.	50msec max. 50msec max.	30msec 25msec	30msec 35msec	50msec max. 50msec max.
Switching frequency	400 \pm 30kHz	500 to 650kHz	500 to 650kHz	290 \pm 30kHz	260 to 410kHz	230 to 265kHz	240 \pm 25kHz	200kHz
ENVIRONMENTAL								
Calculated MTBF (4)	TBC							
Operating Temperature Range (9) (Ambient) No baseplate, 200 LFM, no derating, vertical mount	-40 to +75°C	-40 to +TBD	-40 to +62°C	-40 to +72°C	-40 to +70°C (1)	-40 to +62°C	-40 to +57°C	-40 to +70°C
With Derating	See Derating curves							
Operating Temperature with baseplate (no derating required) (3) (13)	-40 to +110°C	-40 to +110°C	-40 to +110°C	-40 to +110°C	-40 to +110°C	-40 to +115°C	-40 to +110°C	-40 to +110°C
Storage Temperature	-55 to +125°C							
Thermal Protection/Shutdown	+120°C	+115°C	+115°C	+110°C	+125°C	+110°C	+110°C	+110°C
Relative Humidity	To +85°C/85% non-condensing							
PHYSICAL								
Outline Dimensions	See mechanical specifications							
Baseplate Material	Aluminum							
Pin Material/Diameter	Brass alloy / 0.04/0.062 inches 1.016/1.524 mm							
Weight	1 ounce (28 grams)							
Electromagnetic Interference (conducted and radiated) (external filter required)	FCC part 15, class B, EN55022							
Safety	UL/cUL 60950, CSA-C22.2 No.60950, IEC/EN 60950							

Low-Profile, Isolated Quarter-Brick 2.5-40 Amp DC/DC Converters

Performance/Functional Specifications 48V Models Typical @ $T_A = +25^\circ\text{C}$ under nominal line voltage, nominal output voltage, natural air convection, external caps and full-load conditions, unless noted. (1)

	UVQ-2.5/40-D48	UVQ-3.3/35-D48	UVQ-5/20-D48	UVQ-12/10-D48	UVQ-15/7-D48	UVQ-18/6-D48	UVQ-24/4.5-D48	UVQ-48/2.5-D48
INPUT								
Input Voltage Range								
Start-up Threshold, min.	35.9 Volts	35.9 Volts	35.9 Volts	35.5 Volts	35.5 Volts	35.5 Volts	36 Volts	35.9 Volts
Undervoltage Shutdown (14)	33.5 Volts	33.5 Volts	31 Volts	31 Volts	32 Volts	31 Volts	33.5 Volts	33.5 Volts
Overvoltage Shutdown (11)	none	none	none	none	none	none	none	none
Reflected (back) Ripple Current (2)	10mA _{p-p}	10mA _{p-p}	10mA _{p-p}	8mA _{p-p}	20mA _{p-p}	50mA _{p-p}	10mA _{p-p}	5mA _{p-p}
Input Current								
Full load conditions								
Inrush transient	0.05A ² sec	0.05A ² sec	1A ² sec	1A ² sec	0.1A ² sec	1A ² sec	0.05A ² sec	0.05A ² sec
Output short circuit	50mA	50mA	50mA	10mA	50mA	50mA	50mA	50mA
No load	100mA	130mA	80mA	60mA	60mA	80mA	45mA	30mA
Low line ($V_{in} = \text{min.}$)	3.15 Amps	3.56 Amps	3.07 Amps	5.93 Amps	3.21 Amps	3.35 Amps	3.19 Amps	3.64 Amps
Standby mode (Off, UV, OT shutdown)	2mA	1mA	1mA	4mA	1mA	1mA	1mA	1mA
Internal Input Filter Type	L-C	L-C	L-C	L-C	Pi-type	Pi-type	Pi-type	L-C
Reverse Polarity Protection								
Remote On/Off Control (5)								
Positive logic, "P" suffix (specifications are max.)	OFF = Gnd. to +0.8V ON = open or 5V to + V_{in}	OFF = Gnd. to +0.8V ON = open or 5V to + V_{in}	OFF = Gnd. to +0.8V ON = open or 3.5V to 15V	OFF = Gnd. to +0.8V ON = open or 5V to + V_{in}	OFF = Gnd. to +0.8V ON = open or 3.5V to 13.5V	OFF = Gnd. to +0.8V ON = open or 3.5V to 15V	OFF = Gnd. to +0.8V ON = open or 3.5V to 13.5V	OFF = Gnd. to +1V ON = open or 3.5 to 13.5V
Negative logic, "N" suffix (specifications are max.)	OFF = open or +5V to + V_{in} ON = Gnd. to +0.8V	OFF = open or +5V to + V_{in} ON = Gnd. to +0.8V	OFF = open or +5V to + V_{in} ON = Gnd.	OFF = open or +5V to + V_{in} ON = Gnd. to +0.8V	OFF = open or 3.5V-13.5V ON = Gnd. to +1V	OFF = open or 3.5V to 13.5V ON = Gnd. to +1V	OFF = open or 3.5V to 13.5V ON = Gnd. to +1V	OFF = open or 3.5 to 13.5V ON = Gnd. to +1V
Current	8mA	8mA	1mA	8mA	1mA	1mA	1mA	1mA

Low-Profile, Isolated Quarter-Brick 2.5-40 Amp DC/DC Converters

Performance/Functional Specifications 48V Models Typical @ $T_A = +25^\circ\text{C}$ under nominal line voltage, nominal output voltage, natural air convection, external caps and full-load conditions, unless noted. (1)

	UVQ-2/5/10-48	UVQ-3/3/35-D48	UVQ-5/20-D48	UVQ-12/10-D48	UVQ-15/7-D48	UVQ-18/6-D48	UVQ-24/4/5-D48	UVQ-48/2/5-D48
OUTPUT								
Voltage Output Range	See ordering guide							
Voltage Output Accuracy	$\pm 1.5\%$ of V_{NOM} (50% load)	$\pm 1\%$ of V_{NOM} (50% load)	$\pm 1\%$ of V_{NOM} (50% load)	$\pm 1.25\%$ of V_{NOM} (50% load)	$\pm 1\%$ of V_{NOM} (50% load)	$\pm 1\%$ of V_{NOM} (50% load)	$\pm 1\%$ of V_{NOM} (50% load)	$\pm 1\%$ of V_{NOM} (50% load)
Adjustment Range (12)	-20 to +10% of V_{NOM}							
Temperature Coefficient	$\pm 0.02\%$ of V_{OUT} range/ $^\circ\text{C}$							
Minimum Loading	No min. load	3 Amps	No minimum load					
Remote Sense Compensation	+10%							
Ripple/Noise	See ordering guide (8)							
Line/Load Regulation	See ordering guide (10)							
Efficiency	See ordering guide							
Maximum Capacitive Loading Low ESR <0.02 Ω max., resistive load	10,000 μF	10,000 μF	10,000 μF	4700 μF	4700 μF	2200 μF	4700 μF	10,000 μF
Isolation Voltage								
Input to Output	2250 Volts min.	2250 Volts min.	2250 Volts min.	2250 Volts min	2250 Volts min.	2250 Volts min.	2250 Volts min.	2250 Volts min.
Input fo baseplate	1500 Volts min.							
Baseplate to output	1500 Volts min.	1500 Volts min.	1500 Volts min.	1500 Volts min.	1500 Volts min.	1500 Volts min.	1500 Volts min.	1500 Volts min.
Isolation Resistance	100M Ω							
Isolation Capacitance	1500pF	1500pF	1500pF	1000pF	50pF	50pF	50pF	1500pF
Isolation Safety Rating	Basic insulation							
Current Limit Inception (98% of V_{OUT} , after warmup)	46 Amps	40 Amps	28 Amps	12.5 Amps	8.5 Amps	7 Amps	14 Amps	TBD
Short circuit protection method (6)	Current limiting, hiccup autorestart. Remove overload for recovery.							
Short circuit current	5 Amps	5 Amps	0.1 Amps	1.5 Amps	3 Amps	3 Amps	5 Amps	3.5 Amps
Short circuit duration	Continuous, output shorted to ground (no damage)							
Overvoltage protection via magnetic feedback	3 Volts max.	3 Volts max.	6 Volts max.	14.4 Volts max.	18.5 Volts max.	22 Volts max.	3.96 Volts max.	55 Volts max.

Low-Profile, Isolated Quarter-Brick 2.5-40 Amp DC/DC Converters
Performance/Functional Specifications 48V Models Typical @ $T_A = +25^\circ\text{C}$ under nominal line voltage, nominal output voltage, natural air convection, external caps and full-load conditions, unless noted. (1)

	UVQ-2.5/40-D48	UVQ-3.3/35-D48	UVQ-5/20-D48	UVQ-12/10-D48	UVQ-15/7-D48	UVQ-18/6-D48	UVQ-24/4.5-D48	UVQ-48/2.5-D48
DYNAMIC CHARACTERISTICS								
Dynamic load response	150µsec to $\pm 1\%$ of final value (50-75-50% load step)	150µsec to $\pm 1\%$ of final value (50-75-50% load step)	150µsec to $\pm 1\%$ of final value (50-75-50% load step)	50µsec to $\pm 1\%$ of final value (50-75-50% load step)	50µsec to $\pm 1\%$ of final value (50-75-50% load step)	50µsec to $\pm 1\%$ of final value (50-75-50% load step)	50µsec to $\pm 1\%$ of final value (50-75-50% load step)	50µsec to $\pm 1\%$ of final value (50-75-50% load step)
Start-up time V_{IN} to V_{OUT} regulated Remote On/Off to V_{OUT} regulated	50msec 50msec	50msec 50msec	50msec 50msec	40msec 30msec	30msec 30msec	30msec 30msec	50msec max. 50msec max.	50msec max. 50msec max.
Switching frequency	500 to 650kHz	500 to 650kHz	450 \pm 50kHz	290 \pm 30kHz	250 \pm 15kHz	240 \pm 25kHz	200kHz	540 \pm 40kHz
ENVIRONMENTAL								
Calculated MTBF (4)	TBC							
Operating Temperature Range (9) (Ambient) No baseplate, 200 LFM, no derating, vertical mount	-40 to +50°C	-40 to +34°C	-40 to TBD°C	-40 to +49°C	-40 to +75°C	-40 to +55°C	-40 to +70°C	-40 to +85°C
With Derating	See Derating curves							
Operating Temperature with baseplate (no derating required) (3) (13)	-40 to +110°C	-40 to +110°C	-40 to +110°C	-40 to +110°C	-40 to +115°C	-40 to +110°C	-40 to +110°C	-40 to +120°C
Storage Temperature	-55 to +125°C							
Thermal Protection/ Shutdown	+115°C	+115°C	+125°C	+115°C	+110°C	+110°C	+110°C	+120°C
Relative Humidity	to +85°C/85% non-condensing							
PHYSICAL								
Outline Dimensions	See mechanical specifications							
Baseplate Material	Aluminum							
Pin Material/Diameter	Brass alloy / 0.04/0.062 inches 1.016/1.524 mm							
Weight	1 ounce (28 grams)							
Electromagnetic Interference (conducted and radiated) (external filter required)	FCC part 15, class B, EN55022							
Safety	UL/cUL 60950, CSA-C22.2 No.60950, IEC/EN 60950							

Absolute Maximum Ratings

Input Voltage	24V models	48V models
Continuous	0 to +36V	0 to +75V
Transient (100 mS)	+50V	+100V
On/Off Control	-0.3 V min to +13.5V max.	
Input Reverse Polarity Protection	See Fuse section	
Output Overvoltage	V _{OUT} +20% max.	
Output Current (Note 7)	Current-limited. Devices can withstand sustained short circuit without damage.	
Storage Temperature	-55 to +125°C	
Lead Temperature (soldering 10 sec.)	+280°C	

Absolute maximums are stress ratings. Exposure of devices to any of these conditions may adversely affect long-term reliability. Proper operation under conditions other than those listed in the Performance/Functional Specifications Table is not implied nor recommended.

- (1) All models are tested and specified with 200 LFM airflow, external 1110µF ceramic/tantalum output capacitors. External input capacitance varies according to model type. All capacitors are low ESR types. These capacitors are necessary to accommodate our test equipment and may not be required to achieve specified performance in your applications. All models are stable and regulate within spec under no-load conditions.
General conditions for Specifications are +25°C, V_{IN} = nominal, V_{OUT} = nominal, full load.
- (2) Input Ripple Current is tested and specified over a 5-20MHz bandwidth. Input filtering is C_{IN} = 33µF tantalum, C_{BUS} = 220µF electrolytic, L_{BUS} = 12µH.
- (3) Note that Maximum Power Derating curves indicate an average current at nominal input voltage. At higher temperatures and/or lower airflow, the DC/DC converter will tolerate brief full current outputs if the total RMS current over time does not exceed the Derating curve.
- (4) Mean Time Before Failure is calculated using the Telcordia (Belcore) SR-332 Method 1, Case 3, ground fixed conditions, T_{PCBOARD} = +25°C, full output load, natural air convection.
- (5) The On/Off Control may be driven with external logic or by applying appropriate external voltages which are referenced to Input Common. The On/Off Control Input should use either an open collector/open drain transistor or logic gate which does not exceed +13.5V.
- (6) Short circuit shutdown begins when the output voltage degrades approximately 2% from the selected setting.
- (7) The outputs are not intended to sink appreciable reverse current. Sinking excessive reverse current may damage the outputs.
- (8) Output noise may be further reduced by adding an external filter. See I/O Filtering and Noise Reduction.
- (9) All models are fully operational and meet published specifications, including "cold start" at -40°C.
- (10) Regulation specifications describe the deviation as the line input voltage or output load current is varied from a nominal midpoint value to either extreme.
- (11) Overvoltage shutdown on 48V input models is not supplied in order to comply with telecom reliability requirements. These requirements attempt continued operation despite significant input overvoltage.
- (12) Do not exceed maximum power specifications when adjusting the output trim.
- (13) Note that the converter may operate up to +110°C with the baseplate installed. However, thermal self-protection occurs near +110°C, and there is a temperature gradient between the hotspot and the baseplate. Therefore, +100°C is recommended to avoid thermal shutdown.
- (14) The converter is guaranteed to turn off at the UV shutdown voltage.

TECHNICAL NOTES

Removal of Soldered UVQ's from Printed Circuit Boards

Should removal of the UVQ from its soldered connection be needed, thoroughly de-solder the pins using solder wicks or de-soldering tools. At no time should any prying or leverage be used to remove boards that have not been properly de-soldered first.

Input Source Impedance

UVQ converters must be driven from a low ac-impedance input source. The DC/DC's performance and stability can be compromised by the use of highly inductive source impedances. The input circuit shown in Figure 2 is a practical solution that can be used to minimize the effects of inductance in the input traces. For optimum performance, components should be mounted close to the DC/DC converter.

I/O Filtering, Input Ripple Current, and Output Noise

All models in the UVQ Series are tested/specified for input ripple current (also called input reflected ripple current) and output noise using the circuits and layout shown in Figures 2 and 3.

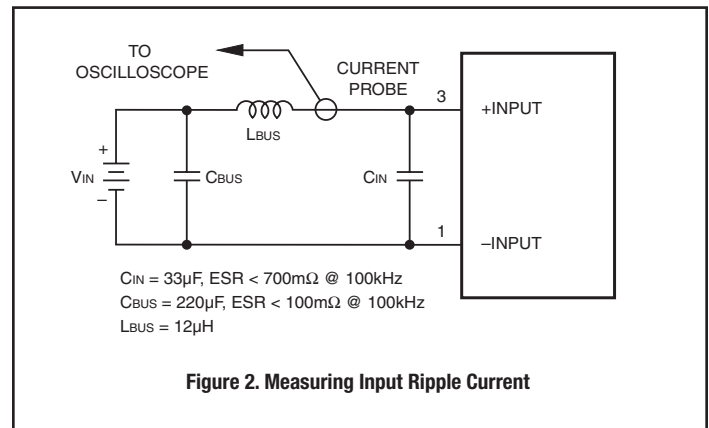

Figure 2. Measuring Input Ripple Current

External input capacitors (C_{IN} in Figure 2) serve primarily as energy-storage elements. They should be selected for bulk capacitance (at appropriate frequencies), low ESR, and high rms-ripple-current ratings. The switching nature of DC/DC converters requires that dc voltage sources have low ac impedance as highly inductive source impedance can affect system stability. In Figure 2, C_{BUS} and L_{BUS} simulate a typical dc voltage bus. Your specific system configuration may necessitate additional considerations.

In critical applications, output ripple/noise (also referred to as periodic and random deviations or PARD) can be reduced below specified limits using filtering techniques, the simplest of which is the installation of additional external output capacitors. Output capacitors function as true filter elements and should be selected for bulk capacitance, low ESR, and appropriate frequency response. In Figure 3, the two copper strips simulate real-world pcb impedances between the power supply and its load. Scope measurements should be made using BNC connectors or the probe ground should be less than 1/2 inch and soldered directly to the fixture.

All external capacitors should have appropriate voltage ratings and be located as close to the converter as possible. Temperature variations for all relevant parameters should be taken into consideration. OS-CON™ organic semiconductor capacitors (www.sanyo.com) can be especially effective for further reduction of ripple/noise.

The most effective combination of external I/O capacitors will be a function of line voltage and source impedance, as well as particular load and layout conditions. Our Applications Engineers can recommend potential solutions and discuss the possibility of our modifying a given device's internal filtering to meet your specific requirements. Contact our Applications Engineering Group for additional details.

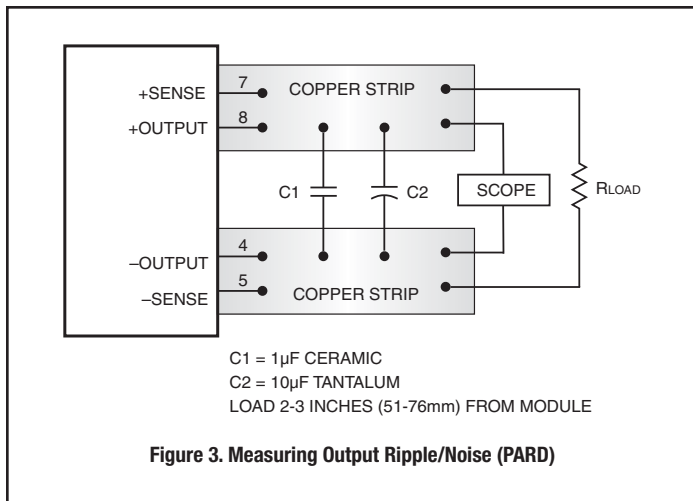

Figure 3. Measuring Output Ripple/Noise (PARD)

Start-Up Threshold and Undervoltage Shutdown

Under normal start-up conditions, the UVQ Series will not begin to regulate properly until the ramping input voltage exceeds the Start-Up Threshold. Once operating, devices will turn off when the applied voltage drops below the Undervoltage Shutdown point. Devices will remain off as long as the undervoltage condition continues. Units will automatically re-start when the applied voltage is brought back above the Start-Up Threshold. The hysteresis built into this function avoids an indeterminate on/off condition at a single input voltage. See Performance/Functional Specifications table for actual limits.

Start-Up Time

The VIN to VOUT Start-Up Time is the interval between the point at which a ramping input voltage crosses the Start-Up Threshold voltage and the point at which the fully loaded output voltage enters and remains within its specified ±1% accuracy band. Actual measured times will vary with input source impedance, external input capacitance, and the slew rate and final value of

the input voltage as it appears to the converter. The On/Off to VOUT start-up time assumes that the converter is turned off via the Remote On/Off Control with the nominal input voltage already applied.

On/Off Control

The primary-side, Remote On/Off Control function (pin 2) can be specified to operate with either positive or negative polarity. Positive-polarity devices ("P" suffix) are enabled when pin 2 is left open or is pulled high. Positive-polarity devices are disabled when pin 2 is pulled low (0-0.8V with respect to -Input). Negative-polarity devices are off when pin 2 is high/open and on when pin 2 is pulled low. See Figure 4.

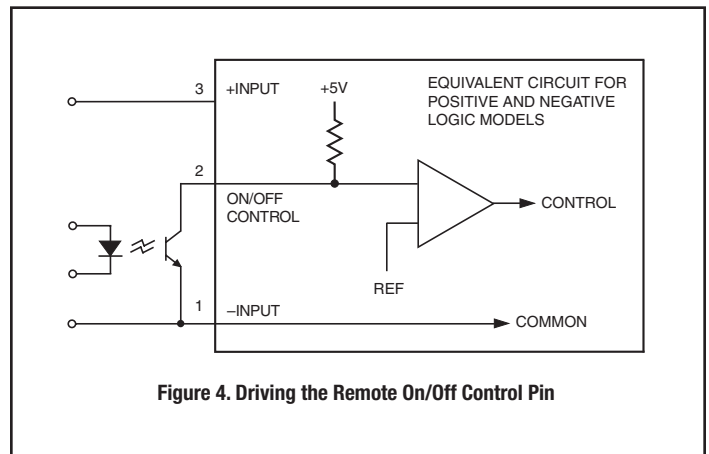

Figure 4. Driving the Remote On/Off Control Pin

Dynamic control of the remote on/off function is best accomplished with a mechanical relay or an open-collector/open-drain drive circuit (optically isolated if appropriate). The drive circuit should be able to sink appropriate current (see Performance Specifications) when activated and withstand appropriate voltage when deactivated.

Current Limiting

When power demands from the output falls within the current limit inception range for the rated output current, the DC/DC converter will go into a current limiting mode. In this condition the output voltage will decrease proportionately with increases in output current, thereby maintaining a somewhat constant power dissipation. This is commonly referred to as power limiting. Current limit inception is defined as the point where the full-power output voltage falls below the specified tolerance. If the load current being drawn from the converter is significant enough, the unit will go into a short circuit condition. See "Short Circuit Condition."

Short Circuit Condition

When a converter is in current limit mode the output voltages will drop as the output current demand increases. If the output voltage drops too low, the magnetically coupled voltage used to develop primary side voltages will also drop, thereby shutting down the PWM controller. Following a time-out period of about 50 milliseconds, the PWM will restart, causing the output voltages to begin ramping to their appropriate values. If the short-circuit condition persists, another shutdown cycle will be initiated. This on/off cycling is referred to as "hiccup" mode. The hiccup cycling reduces the average output current, thereby preventing internal temperatures from rising to excessive levels. The UVQ is capable of enduring an indefinite short circuit output condition.

Thermal Shutdown

UVQ converters are equipped with thermal-shutdown circuitry. If the internal temperature of the DC/DC converter rises above the designed operating temperature (See Performance Specifications), a precision temperature sensor will power down the unit. When the internal temperature decreases below the threshold of the temperature sensor, the unit will self start.

Output Overvoltage Protection

The output voltage is monitored for an overvoltage condition via magnetic coupling to the primary side. If the output voltage rises to a fault condition, which could be damaging to the load circuitry (see Performance Specifications), the sensing circuitry will power down the PWM controller causing the output voltage to decrease. Following a time-out period the PWM will restart, causing the output voltage to ramp to its appropriate value. If the fault condition persists, and the output voltages again climb to excessive levels, the overvoltage circuitry will initiate another shutdown cycle. This on/off cycling is referred to as "hiccup" mode.

Input Reverse-Polarity Protection

If the input-voltage polarity is accidentally reversed, an internal diode will become forward biased and likely draw excessive current from the power source. If the source is not current limited or the circuit appropriately fused, it could cause permanent damage to the converter.

Input Fusing

Certain applications and/or safety agencies may require the installation of fuses at the inputs of power conversion components. Fuses should also be used if the possibility of a sustained, non-current-limited, input-voltage polarity reversal exists. For DATEL UVQ Series DC/DC Converters, slow-blow fuses are recommended with values no greater than twice the maximum input current.

Trimming Output Voltage

UVQ converters have a trim capability (pin 6) that enables users to adjust the output voltage from +10% to -20% (refer to the trim equations). Adjustments to the output voltage can be accomplished with a single fixed resistor as shown in Figures 5 and 6. A single fixed resistor can increase or decrease the output voltage depending on its connection. Resistors should be located close to the converter and have TCR's less than 100ppm/°C to minimize sensitivity to changes in temperature. If the trim function is not used, leave the trim pin open.

Standard UVQ's have a "positive trim" where a single resistor connected from the Trim pin (pin 6) to the +Sense (pin 7) will increase the output voltage. A resistor connected from the Trim Pin (pin 6) to the -Sense (pin 5) will decrease the output voltage.

Trim adjustments greater than the specified +10%/-20% can have an adverse affect on the converter's performance and are not recommended. Excessive voltage differences between V_{OUT} and Sense, in conjunction with trim adjustment of the output voltage, can cause the overvoltage protection circuitry to activate (see Performance Specifications for overvoltage limits).

Temperature/power derating is based on maximum output current and voltage at the converter's output pins. Use of the trim and sense functions can cause output voltages to increase, thereby increasing output power beyond the UVQ's specified rating, or cause output voltages to climb into the output overvoltage region. Therefore:

$$(V_{OUT \text{ at pins}}) \times (I_{OUT}) \leq \text{rated output power}$$

The Trim pin (pin 6) is a relatively high impedance node that can be susceptible to noise pickup when connected to long conductors in noisy environments. In such cases, a 0.22µF capacitor to -Output can be added to reduce this long lead effect.

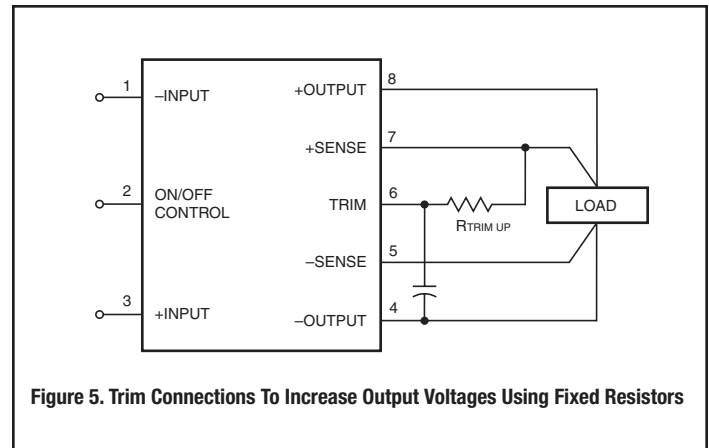

Figure 5. Trim Connections To Increase Output Voltages Using Fixed Resistors

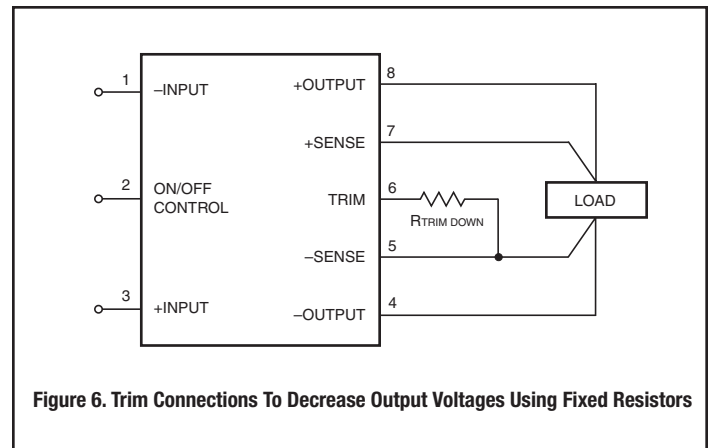

Figure 6. Trim Connections To Decrease Output Voltages Using Fixed Resistors

TRIM EQUATIONS	
Trim Up	Trim Down
UVQ-1.2/40-D48	
$R_{TUP} (k\Omega) = \frac{1.308(V_O - 0.793)}{V_O - 1.2} - 1.413$	$R_{TDOWN} (k\Omega) = \frac{1.037}{1.2 - V_O} - 1.413$
UVQ-1.5/40-D48	
$R_{TUP} (k\Omega) = \frac{6.23(V_O - 1.226)}{V_O - 1.5} - 10.2$	$R_{TDOWN} (k\Omega) = \frac{7.64}{1.5 - V_O} - 10.2$
UVQ-1.8/40-D48	
$R_{TUP} (k\Omega) = \frac{7.44(V_O - 1.226)}{V_O - 1.8} - 10.2$	$R_{TDOWN} (k\Omega) = \frac{9.12}{1.8 - V_O} - 10.2$
UVQ-2.5/40-D48	
$R_{TUP} (k\Omega) = \frac{10(V_O - 1.226)}{V_O - 2.5} - 10.2$	$R_{TDOWN} (k\Omega) = \frac{12.26}{2.5 - V_O} - 10.2$
UVQ-3.3/35-D48	
$R_{TUP} (k\Omega) = \frac{13.3(V_O - 1.226)}{V_O - 3.3} - 10.2$	$R_{TDOWN} (k\Omega) = \frac{16.31}{3.3 - V_O} - 10.2$
UVQ-5/25-D24, UVQ-5/20-D48	
$R_{TUP} (k\Omega) = \frac{20.4(V_O - 1.226)}{V_O - 5} - 10.2$	$R_{TDOWN} (k\Omega) = \frac{25.01}{5 - V_O} - 10.2$
UVQ-12/8-D24, -12/10-D48	
$R_{TUP} (k\Omega) = \frac{49.6(V_O - 1.226)}{V_O - 12} - 10.2$	$R_{TDOWN} (k\Omega) = \frac{60.45}{12 - V_O} - 10.2$
UVQ-15/7-D24, -D48	
$R_{TUP} (k\Omega) = \frac{62.9(V_O - 1.226)}{V_O - 15} - 10.2$	$R_{TDOWN} (k\Omega) = \frac{76.56}{15 - V_O} - 10.2$
UVQ-18/5.6-D24, -18/6-D48	
$R_{TUP} (k\Omega) = \frac{75.5(V_O - 1.226)}{V_O - 18} - 10.2$	$R_{TDOWN} (k\Omega) = \frac{92.9}{18 - V_O} - 10.2$
UVQ-24/4.5-D24, -D48	
$R_{TUP} (k\Omega) = \frac{101(V_O - 1.226)}{V_O - 24} - 10.2$	$R_{TDOWN} (k\Omega) = \frac{124.2}{24 - V_O} - 10.2$
UVQ-48/2.5-D48	
$R_{TUP} (k\Omega) = \frac{210.75(V_O - 1.226)}{V_O - 48} - 10.2$	$R_{TDOWN} (k\Omega) = \frac{250}{48 - V_O} - 10.2$

Note: Higher output 24V and 48V converters require larger, low-tempco, precision trim resistors. An alternative is a low-TC multi-turn potentiometer (20k Ω typical) connected between +V_{OUT} and -V_{OUT} with the wiper to the Trim pin.

TYPICAL PERFORMANCE CURVES

UVQ-1.5/40-D24N: Maximum Current Temperature Derating
(No baseplate, $V_{IN} = 24V$, transverse air flow)

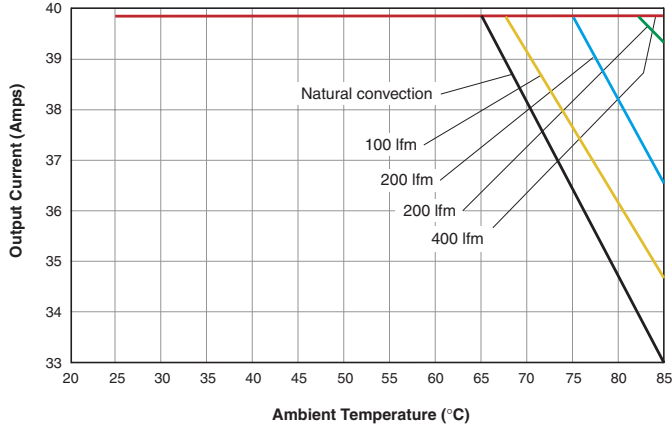

UVQ-1.5/40-D24N: Maximum Current Temperature Derating
(With baseplate, $V_{IN} = 24V$, transverse air flow)

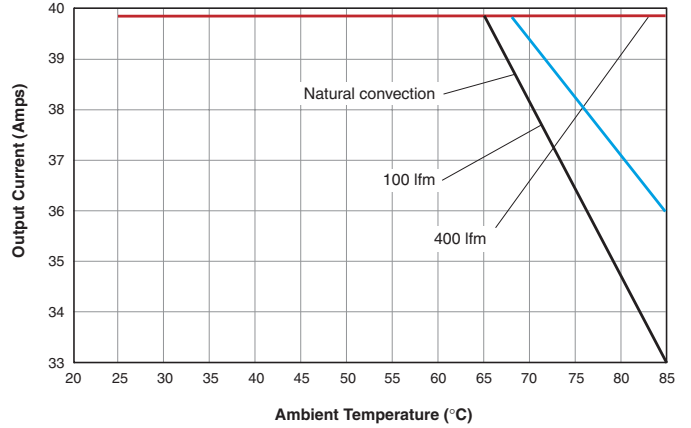

UVQ-2.5/40-D48N
Efficiency vs. Line Voltage and Load Current @ 25°C

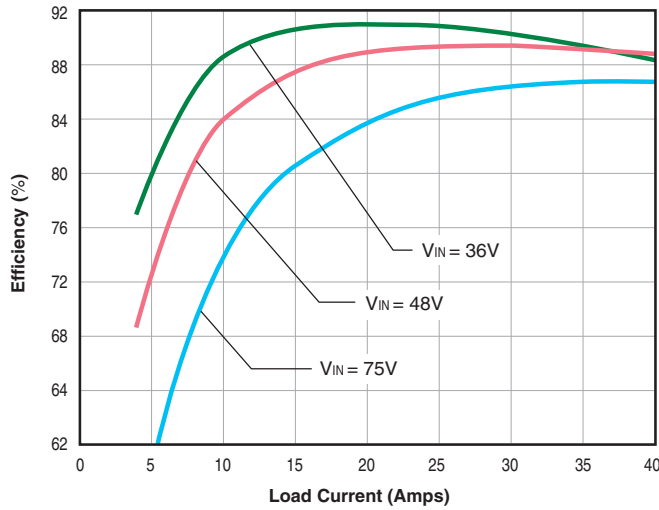

UVQ-2.5/40-D48
Power Dissipation vs. Load Current @ 25°C

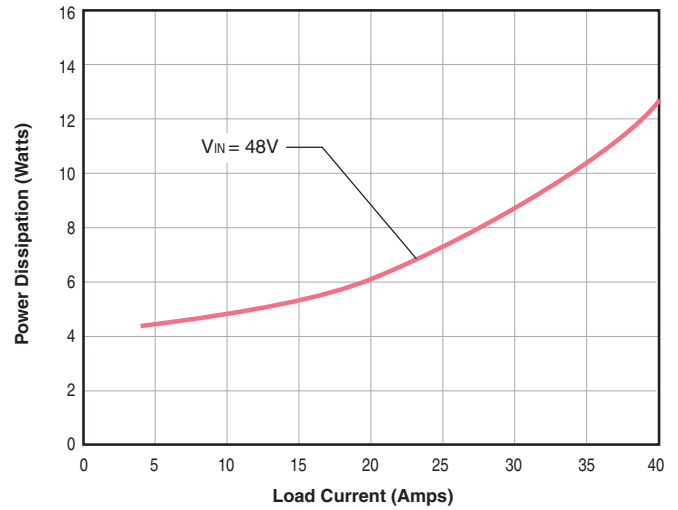

UVQ-3.3/30-D24N: Maximum Current Temperature Derating
(No baseplate, $V_{IN} = 24V$, transverse air flow at sea level)

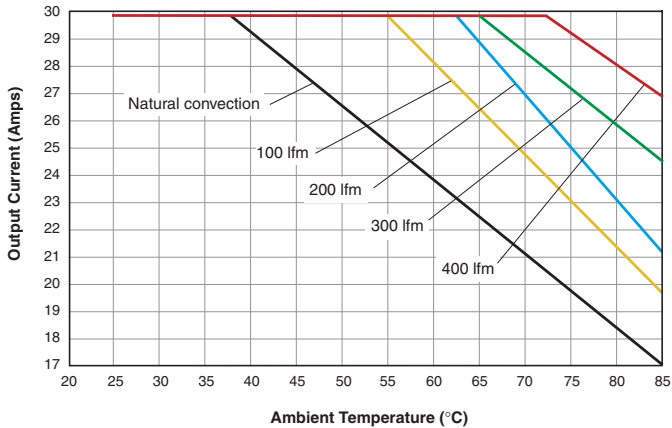

UVQ-3.3/30-D24N: Maximum Current Temperature Derating
(With baseplate, $V_{IN} = 24V$, transverse air flow at sea level)

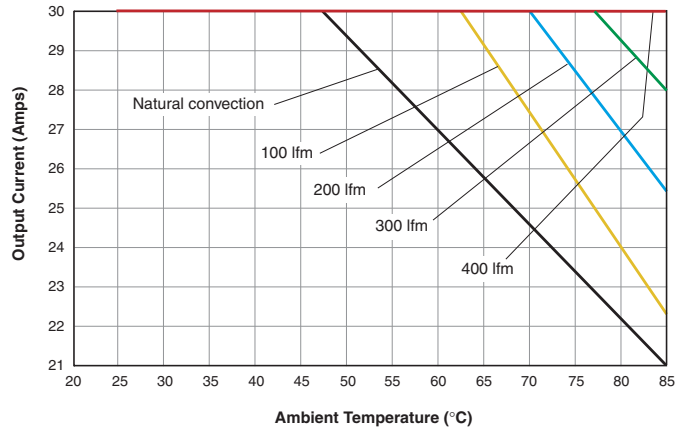

TYPICAL PERFORMANCE CURVES

UVQ-3.3/35-D48 Maximum Current Temperature Derating
(With baseplate, $V_{IN} = 48V$, transverse air flow at sea level)

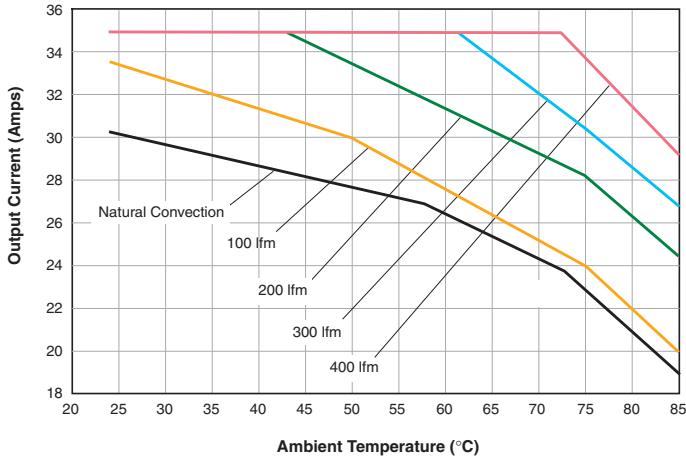

UVQ-5/20-D48 Efficiency vs. Line Voltage and Load Current @ 25°C

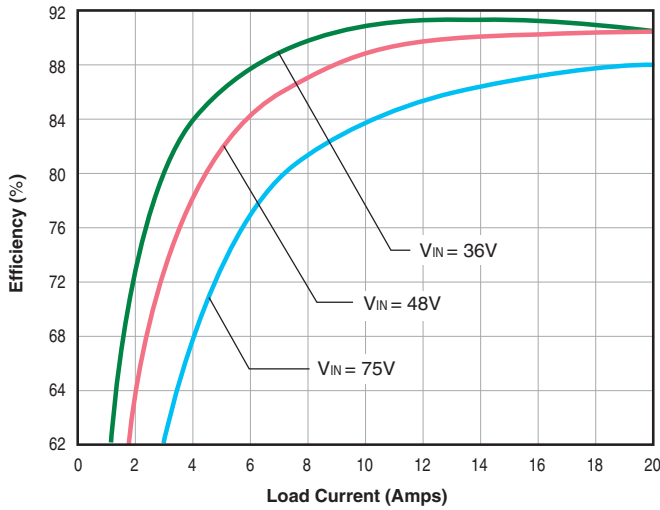

UVQ-5/20-D48P: Maximum Current Temperature Derating
(No baseplate, $V_{IN} = 48V$, transverse air flow at sea level)

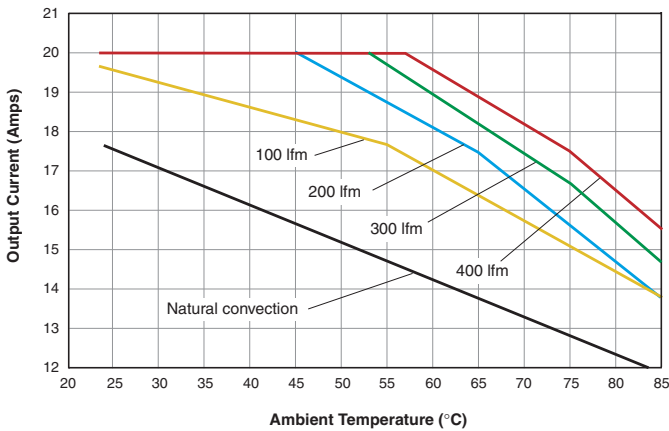

UVQ-5/20-D48PB: Maximum Current Temperature Derating
(With baseplate, $V_{IN} = 48V$, transverse air flow at sea level)

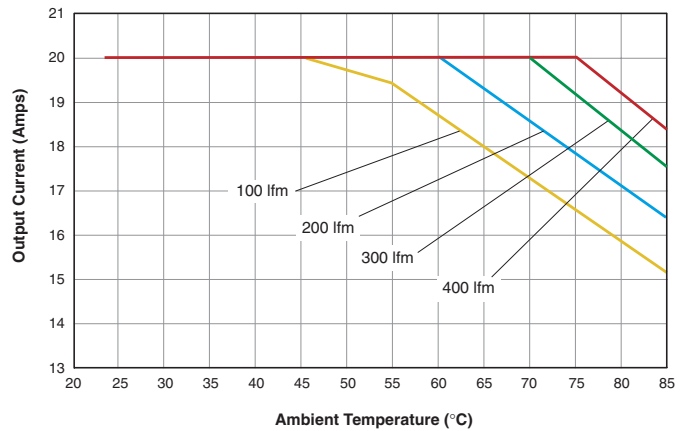

TYPICAL PERFORMANCE CURVES

UVQ-18/5.6-D24
Efficiency vs. Line Voltage and Load Current @ 25°C

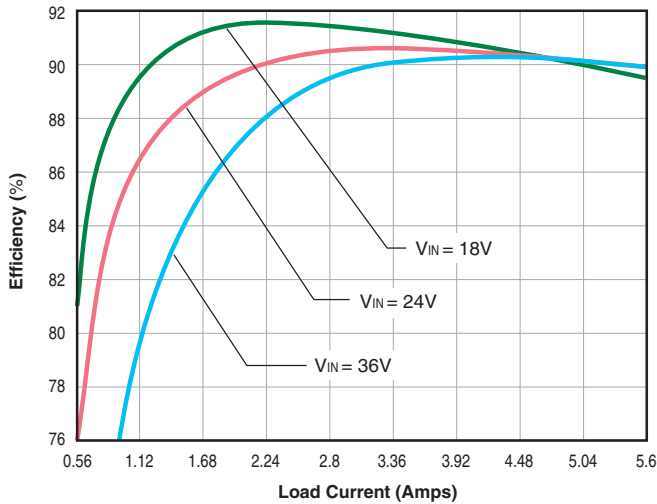

UVQ-18/5.6-D24: Maximum Current Temperature Derating
(No baseplate, $V_{IN} = 24V$, transverse air flow)

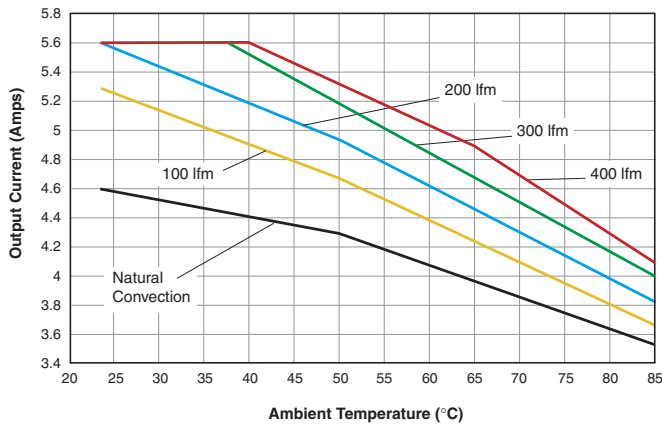

UVQ-18/5.6-D24: Maximum Current Temperature Derating
(With baseplate, $V_{IN} = 24V$, transverse air flow)

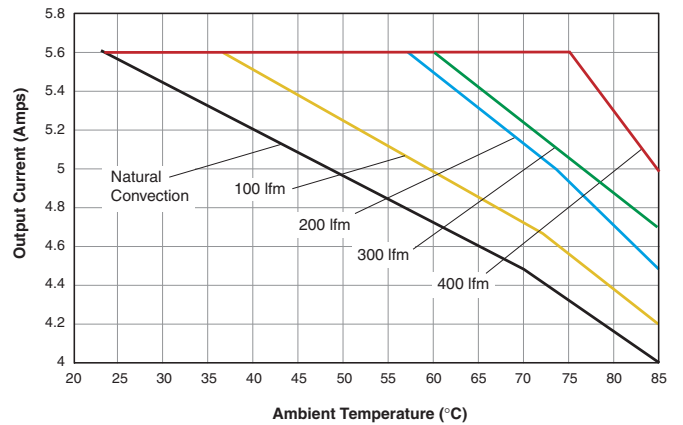

UVQ-18/6-D48N
Efficiency vs. Line Voltage and Load Current @ 25°C

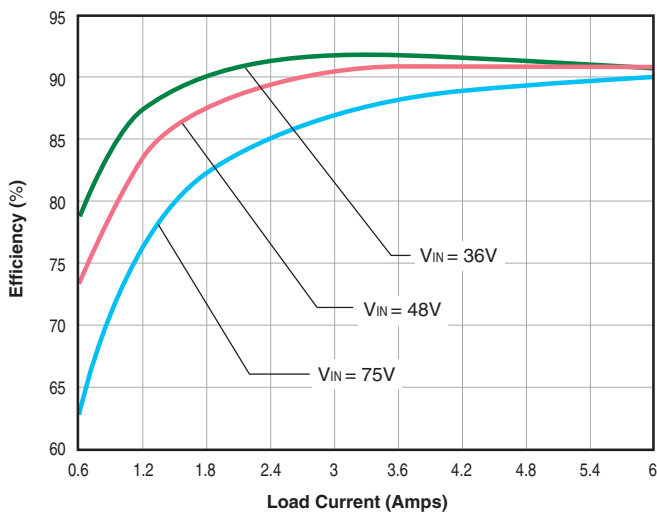

UVQ-18/6-D48
Power Dissipation vs. Load Current @ 25°C

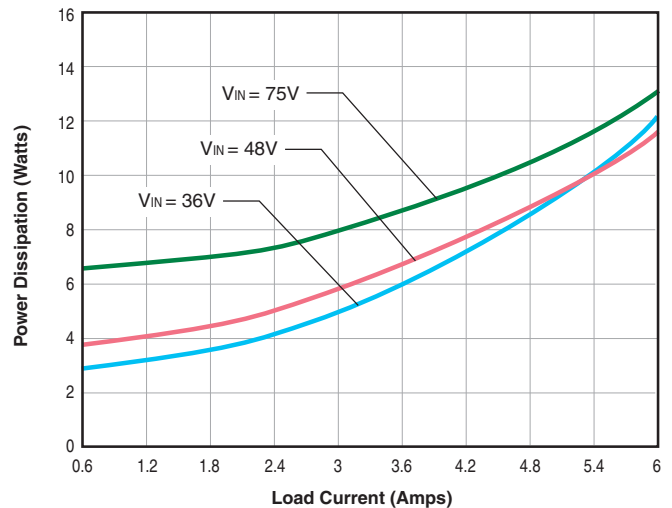

TYPICAL PERFORMANCE CURVES

UVQ-18/6-D48: Maximum Current Temperature Derating
(With baseplate, $V_{IN} = 48V$, transverse air flow)

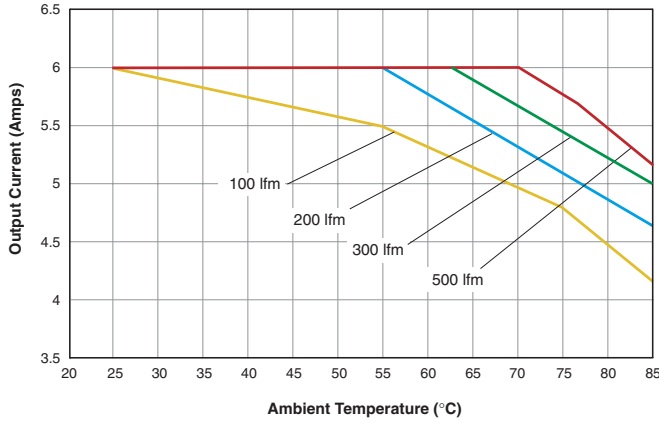

UVQ-18/6-D48: Maximum Current Temperature Derating
(No baseplate, $V_{IN} = 48V$, transverse air flow)

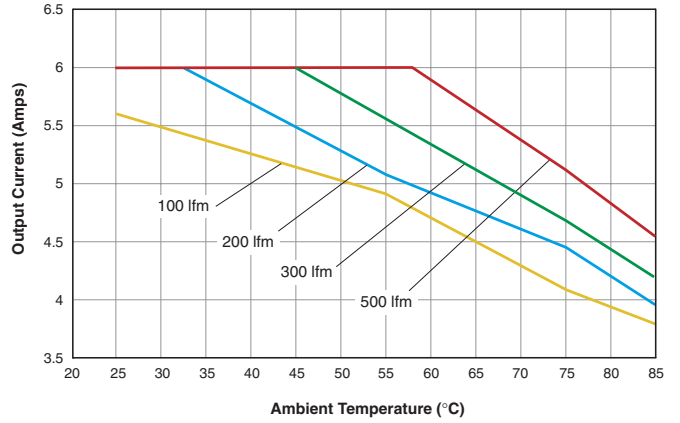

UVQ-48/2.5-D48N
Efficiency vs. Line Voltage and Load Current @ 25°C

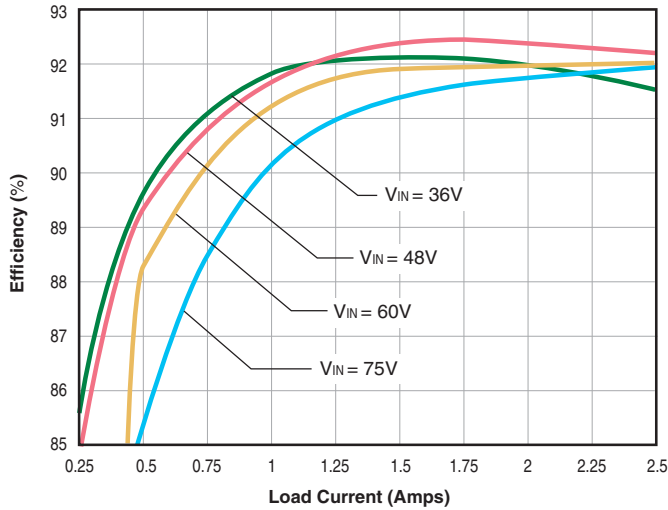

UVQ-48/2.5-D48N: Maximum Current Temperature Derating
(With baseplate, $V_{IN} = 48V$, transverse air flow)

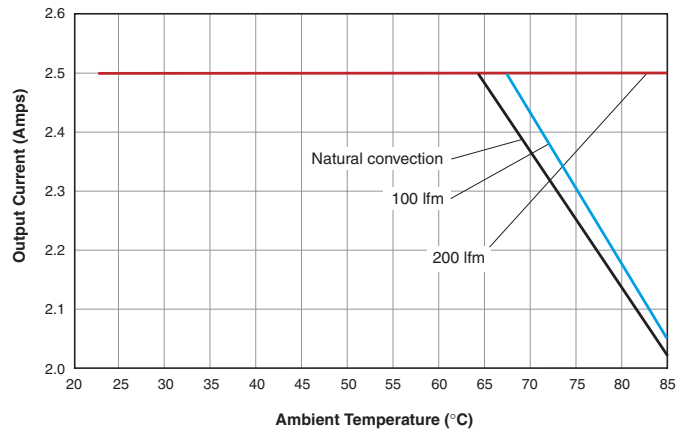

UVQ Series Aluminum Heatsink

The UVQ series converter baseplate can be attached either to an enclosure wall or a heatsink to remove heat from internal power dissipation. The discussion below concerns only the heatsink alternative. The UVQ's are available with a low-profile extruded aluminum heatsink kit, models HS-QB25-UVQ, HS-QB50-UVQ, and HS-QB100-UVQ. This kit includes the heatsink, thermal mounting pad, screws and mounting hardware. See the assembly diagram below. Do not overtighten the screws in the tapped holes in the converter. This kit adds excellent thermal performance without sacrificing too much component height. See the Mechanical Outline Drawings for assembled dimensions. If the thermal pad is firmly attached, no thermal compound ("thermal grease") is required.

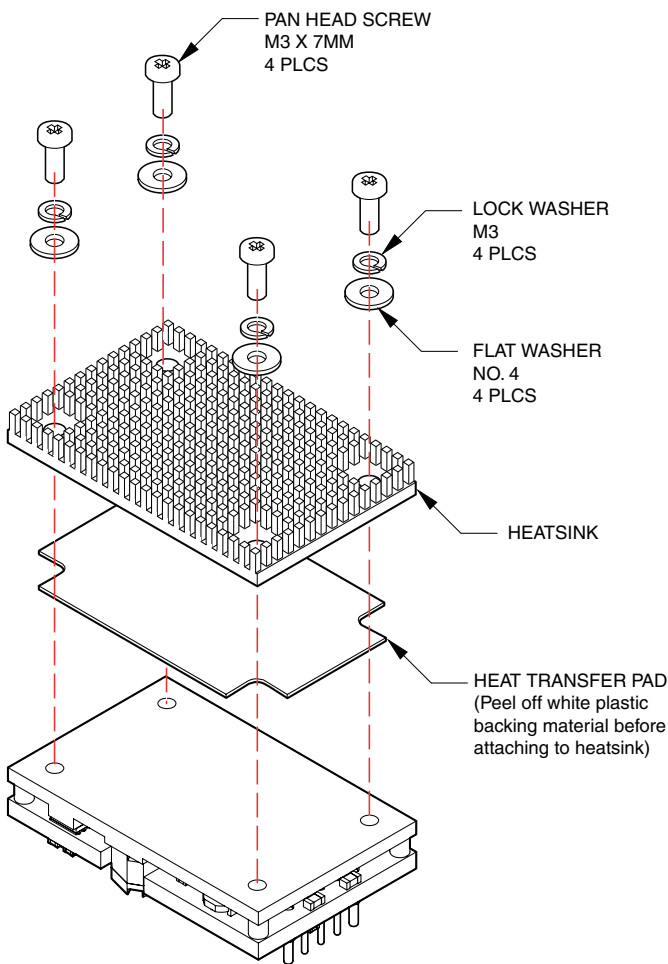

Figure 7. Model UVQ Heatsink Assembly Diagram

When assembling these kits onto the converter, include ALL kit hardware to assure adequate mechanical capture and proper clearances. Thread relief is 0.090" (2.3mm).

Thermal Performance

The HS-QB25-UVQ heatsink has a thermal resistance of 12 degrees Celsius per Watt of internal heat dissipation with "natural convection" airflow (no fans or other mechanical airflow) at sea level altitude. This thermal resistance assumes that the heatsink is firmly attached using the supplied thermal pad and that there is no nearby wall or enclosure surface to inhibit the airflow. The thermal pad adds a negligible series resistance of approximately 0.5°C/Watt so that the total assembled resistance is 12.5°C/Watt.

Be aware that we need to handle only the internal heat dissipation, not the full power output of the converter. This internal heat dissipation is related to the efficiency as follows:

$$\text{Power Dissipation [Pd]} = \text{Power In} - \text{Power Out} \quad [1]$$

$$\text{Power Out} / \text{Power In} = \text{Efficiency [in \%]} / 100 \quad [2]$$

$$\text{Power Dissipation [Pd]} = \text{Power In} \times (1 - \text{Efficiency\%/100}) \quad [3]$$

$$\text{Power Dissipation [Pd]} = \text{Power Out} \times (1 / (\text{Efficiency\%/100}) - 1) \quad [4]$$

Efficiency of course varies with input voltage and the total output power. Please refer to the Performance Curves.

Since many applications do include fans, here is an approximate equation to calculate the net thermal resistance:

$$R_{\Theta} [\text{at airflow}] = R_{\Theta} [\text{natural convection}] / (1 + (\text{Airflow in LFM}) \times [\text{Airflow Constant}]) \quad [5]$$

Where,

$R_{\Theta} [\text{at airflow}]$ is the net thermal resistance (in °C/W) with the amount of airflow available and,

$R_{\Theta} [\text{natural convection}]$ is the still air total path thermal resistance or in this case 12.5°C/Watt and,

"Airflow in LFM" is the net air movement flow rate immediately at the converter.

This equation simplifies an otherwise complex aerodynamic model but is a useful starting point. The "Airflow Constant" is dependent on the fan and enclosure geometry. For example, if 200 LFM of airflow reduces the effective natural convection thermal resistance by one half, the airflow constant would be 0.005. There is no practical way to publish a "one size fits all" airflow constant because of variations in airflow direction, heatsink orientation, adjacent walls, enclosure geometry, etc. Each application must be determined empirically and the equation is primarily a way to help understand the cooling arithmetic.

This equation basically says that small amounts of forced airflow are quite effective removing the heat. But very high airflows give diminishing returns. Conversely, no forced airflow causes considerable heat buildup. At zero airflow, cooling occurs only because of natural convection over the heatsink. Natural convection is often well below 50 LFM, not much of a breeze.

While these equations are useful as a conceptual aid, most users find it very difficult to measure actual airflow rates at the converter. Even if you know the velocity specifications of the fan, this does not usually relate directly to the enclosure geometry. Be sure to use a considerable safety margin doing thermal analysis. If in doubt, measure the actual heat sink temperature with a calibrated thermocouple, RTD or thermistor. Safe operation should keep the heat sink below 100°C.

Calculating Maximum Power Dissipation

To determine the maximum amount of internal power dissipation, find the ambient temperature inside the enclosure and the airflow (in Linear Feet per Minute – LFM) at the converter. Determine the expected heat dissipation using the Efficiency curves and the converter Input Voltage. You should also compensate for lower atmospheric pressure if your application altitude is considerably above sea level.

The general procedure is to compute the expected temperature rise of the heatsink. If the heatsink exceeds +100°C. either increase the airflow and/or reduce the power output. Start with this equation:

$$\text{Internal Heat Dissipation [Pd in Watts]} = (Ts - Ta) / R\Theta [\text{at airflow}] \quad [6]$$

where “Ta” is the enclosure ambient air temperature and,

where “Ts” is the heatsink temperature and,

where “RΘ [at airflow]” is a specific heat transfer thermal resistance (in degrees Celsius per Watt) for a particular heat sink at a set airflow rate. We have already estimated RΘ [at airflow] in the equations above.

Note particularly that Ta is the air temperature inside the enclosure at the heatsink, not the outside air temperature. Most enclosures have higher internal temperatures, especially if the converter is “downwind” from other heat-producing circuits. Note also that this “Pd” term is only the internal heat dissipated inside the converter and not the total power output of the converter.

We can rearrange this equation to give an estimated temperature rise of the heatsink as follows:

$$Ts = (Pd \times R\Theta [\text{at airflow}]) + Ta \quad [7]$$

Heatsink Kit * Model Number	Still Air (Natural convection) thermal resistance	Heatsink height (see drawing)
HS-QB25-UVQ	12°C/Watt	0.25" (6.35mm)
HS-QB50-UVQ	10.6°C/Watt	0.50" (12.7mm)
HS-QB100-UVQ	8°C/Watt	1.00" (25.4mm)

* Kit includes heatsink, thermal pad and mounting hardware.

Heat Sink Example

Assume an efficiency of 92% and power output of 100 Watts. Using equation [4], Pd is about 8.7 Watts at an input voltage of 48 Volts. Using +30°C ambient temperature inside the enclosure, we wish to limit the heat sink temperature to +90°C maximum baseplate temperature to stay well away from thermal shutdown. The +90°C. figure also allows some margin in case the ambient climbs above +30°C or the input voltage varies, giving us less than 92% efficiency. The heat sink and airflow combination must have the following characteristics:

$$8.7 W = (90-30) / R\Theta[\text{airflow}] \text{ or,}$$

$$R\Theta[\text{airflow}] = 60/8.7 = 6.9^\circ\text{C/W}$$

Since the ambient thermal resistance of the heatsink and pad is 12.5°C/W, we need additional forced cooling to get us down to 6.9°C/W. Using a hypothetical airflow constant of 0.005, we can rearrange equation [5] as follows:

$$(\text{Required Airflow, LFM}) \times (\text{Airflow Constant}) = R\Theta[\text{Nat.Convection}] / R\Theta[\text{at airflow}] - 1$$

or,

$$(\text{Required Airflow, LFM}) \times (\text{Airflow Constant}) = 12.5/6.9 - 1 = 0.81$$

and, rearranging again,

$$(\text{Required Airflow, LFM}) = 0.81/0.005 = 162 \text{ LFM}$$

162 LFM is the minimum airflow to keep the heatsink below +90°C. Increase the airflow to several hundred LFM to reduce the heatsink temperature further and improve life and reliability.

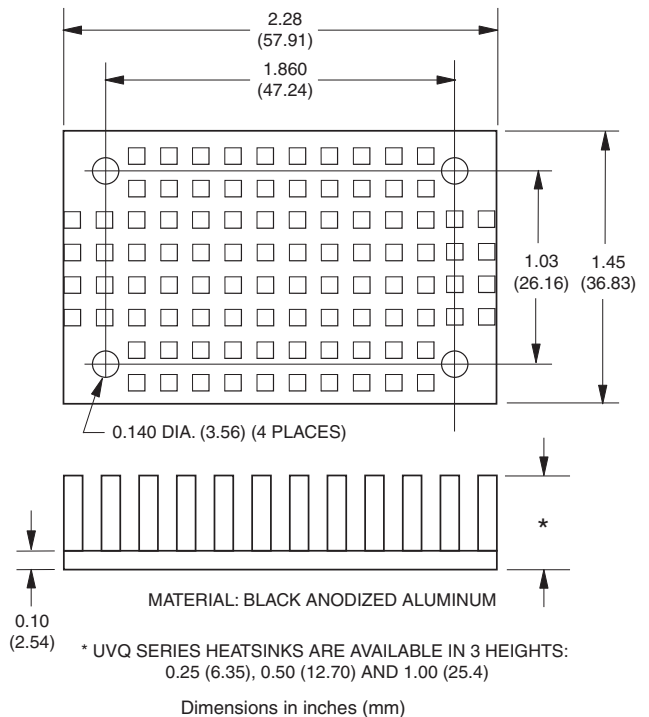

Optional Heatsink

MECHANICAL SPECIFICATIONS

Case C59

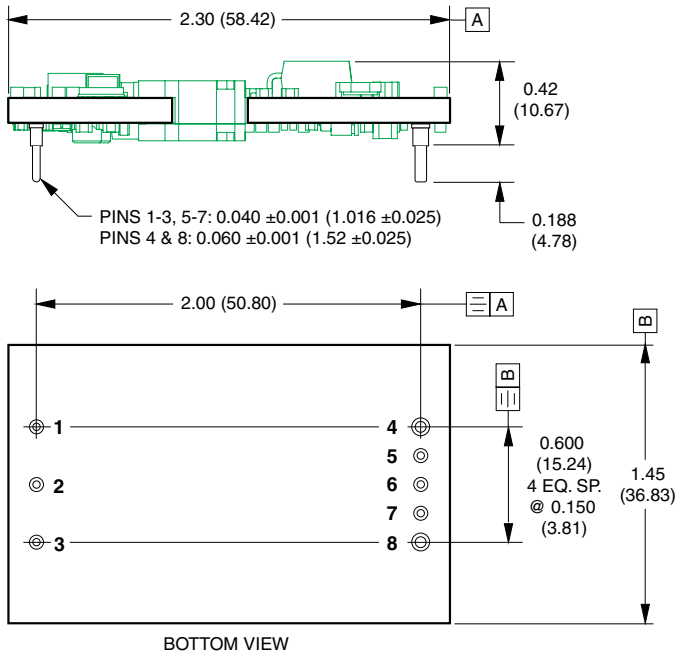

BOTTOM VIEW

DIMENSIONS ARE IN INCHES (MM)

Alternate pin lengths are available. Contact DATEL.

I/O CONNECTIONS	
Pin	Function P32
1	-Input
2	On/Off Control
3	+Input
4	-Output
5	-Sense
6	Output Trim
7	+Sense
8	+Output

* The Remote On/Off can be provided with either positive (P suffix) or negative (N suffix) polarity.

Optional baseplate pin is special order. Contact DATEL.

Case C59 With Baseplate

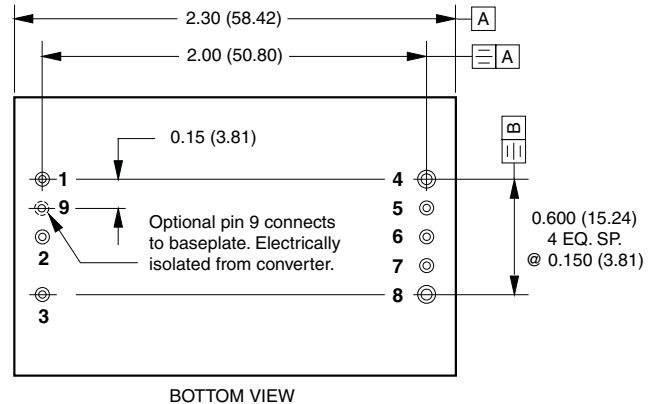
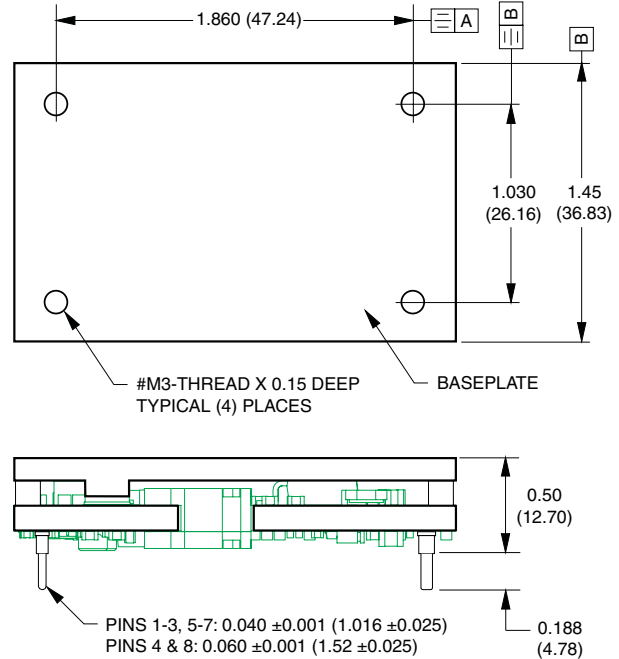

BOTTOM VIEW



C&D Technologies (DATEL), Inc.
 11 Cabot Boulevard, Mansfield, MA 02048-1151 U.S.A.
 Tel: (508) 339-3000 (800) 233-2765 Fax: (508) 339-6356
www.cd4power.com Email: **sales@cdtechno.com**
ISO 9001 REGISTERED

DS-0549 06/06

C&D Technologies (NCL), Ltd. Milton Keynes, United Kingdom, Tel: 44 (0) 1908 615232
 Internet: www.cd4power.com E-mail: ped.ltd@cdtechno.com

C&D Technologies (DATEL) S.A.R.L. Montigny Le Bretonneux, France Tel: 01-34-60-01-01
 Internet: www.cd4power.com E-mail: ped.sarl@cdtechno.com

C&D Technologies (DATEL) GmbH München, Germany Tel: 89-544334-0
 Internet: www.cd4power.com E-mail: ped.gmbh@cdtechno.com

C&D Technologies KK Tokyo, Japan Tel: 3-3779-1031, Osaka Tel: 6-6354-2025
 Int.: www.cd4power.jp Email: sales_tokyo@cdtechno.com, sales_osaka@cdtechno.com

China Shanghai, People's Republic of China Tel: 86-50273678
 Internet: www.cd4power.com E-mail: shanghai@cdtechno.com

C&D Technologies (DATEL), Inc. makes no representation that the use of its products in the circuits described herein, or the use of other technical information contained herein, will not infringe upon existing or future patent rights. The descriptions contained herein do not imply the granting of licenses to make, use, or sell equipment constructed in accordance therewith. Specifications are subject to change without notice. The DATEL logo is a registered trademark of C&D Technologies, Inc..