

DIN W48 × H48mm Digital backlight LCD Timer

Features

Powerful functions upgraded

- Mounting space saving with compact design : downsized by approx. 22% in depth compared to existing models (Length of panel on the back side is 56mm)
- Available to set each value and time range separately when choosing Flicker (FK, FK I) or ON-OFF Delay (ON OFF D, ON OFF D I) output mode (Existing model: setting value only)
- Add Flicker 1 mode (LE4SA)
- Set One-shot output time (0.01~99.99sec.) (Existing model: Fixed 0.5 sec.)
- Time range is configurable (Time setting range to 9.999sec.) : Able to set to 0.001sec. (Existing model: 0.01sec.)
- Choose Min. input signal: 1ms or 20ms (Existing model: Fixed 20ms) (LE4S)
- Improved return time: 100ms (Existing model: 300ms, 500ms)
- Back light ON/OFF function

Original Features

- Wide time range (0.01sec~9999hour)
- Lock setting function for saving setting value.
- Function setting with soft touch
- High visibility display with back light

⚠ Please read "Caution for your safety" in operation manual before using.



Upgrade

(A) Counter

(B) Timer

(C) Temp. controller

(D) Power controller

(E) Panel meter

(F) Tacho/ Speed/ Pulse meter

(G) Display unit

(H) Sensor controller

(I) Switching power supply

(J) Proximity sensor

(K) Photo electric sensor

(L) Pressure sensor

(M) Rotary encoder

(N) Stepping motor & Driver & Controller

(O) Graphic panel

(P) Field network device

(Q) Production stoppage models & replacement

Ordering information

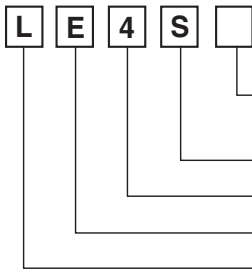

	Time-limit contact 1c
A	Time-limit contact 2c, Time-limit contact 1c+Instantaneous contact 1c(Selectable)
S	DIN W48mm × H48mm
4	9999(Digit)
E	Timer
L	LCD Display

*Socket required : PG-08, PS-08, PS-M08

Specifications

Model		LE4S	LE4SA
Function		Multi time and operation	
Display method		LCD Display (Backlight)	
Power supply		24-240VAC 50/60Hz, 24-240VDC	
Allowable voltage range		90~110% of rated voltage	
Power consumption		24-240VAC: Max. 4.5VA, 24-240VDC: Max. 2W	24-240VAC: Max. 4VA, 24-240VDC: Max. 1.6W
Return time		Max. 100ms	
Min. input signal	START	1ms, 20ms(Selectable)	_____
	INHIBIT		
	RESET		
Input	START	●No-voltage input Impedance at short-circuit: Max. 1kΩ, Residual voltage: Max. 0.5V, Impedance at open-circuit: Min. 100kΩ	_____
	INHIBIT		
	RESET		
Timing operation		Signal ON Start	Power ON Start
Control output	Contact type	Time limit SPDT(1c)	Time limit DPDT(2c), Time limit SPDT(1c) + Instantaneous SPDT(1c):Selectable
	Contact capacity	250VAC 5A resistive load	250VAC 3A resistive load
Relay life cycle	Mechanical	Min. 10,000,000 operations	
	Electrical	1Min. 100,000 operations at 250VAC 2A resistive load	
Output mode		10 kinds of operation mode	8 kinds of operation mode

LE4S Series

Specifications

Ambient temperature	-10 ~ 55°C (at non-freezing status)	
Storage temperature	-25 ~ 65°C (at non-freezing status)	
Ambient humidity	35 ~ 85%RH	
Repeat error	Max. $\pm 0.005\%$ $\pm 0.03\text{sec}$ (Signal Start) Max. $\pm 0.01\%$ $\pm 0.05\text{sec}$ (Power ON Start)	Max. $\pm 0.01\%$ $\pm 0.05\text{sec}$
Setting error		
Voltage error		
Temperature error		
Insulation resistance	100M Ω (500VDC megger)	
Dielectric strength	2000VAC 50/60Hz for 1 minute	
Noise strength	$\pm 2\text{kV}$ the square wave noise (pulse width:1 μs) by the noise simulator	
Vibration	Mechanical	0.75mm amplitude at frequency of 10 ~ 55Hz in each of X, Y, Z directions for 1hour
	Malfunction	0.5mm amplitude at frequency of 10 ~ 55Hz in each of X, Y, Z directions for 10 minutes
Shock	Mechanical	300m/s ² (30G) X, Y, Z directions for 3 times
	Malfunction	100m/s ² (10G) X, Y, Z directions for 3 times
Approval		
Unit weight	Approx. 98g	

Dimensions

(Unit:mm)

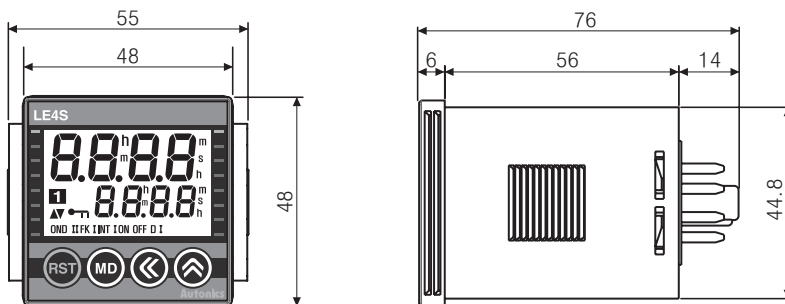

Panel cut-out

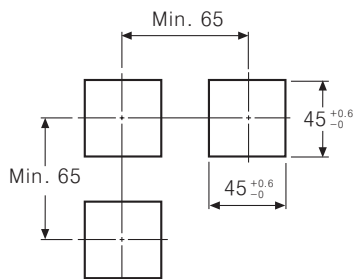

Product mounting

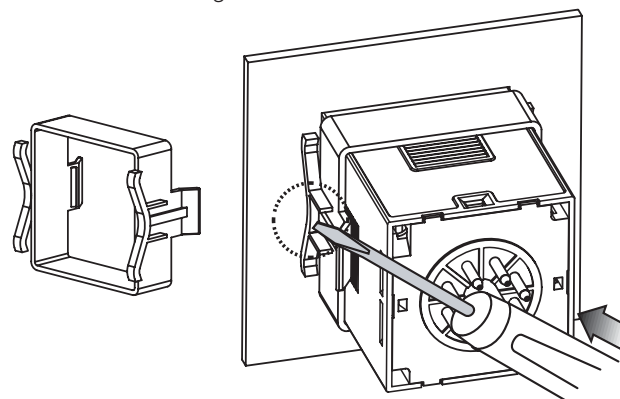

※Insert product into a panel, fasten bracket by pushing with tools as shown above.

Connections

LE4S

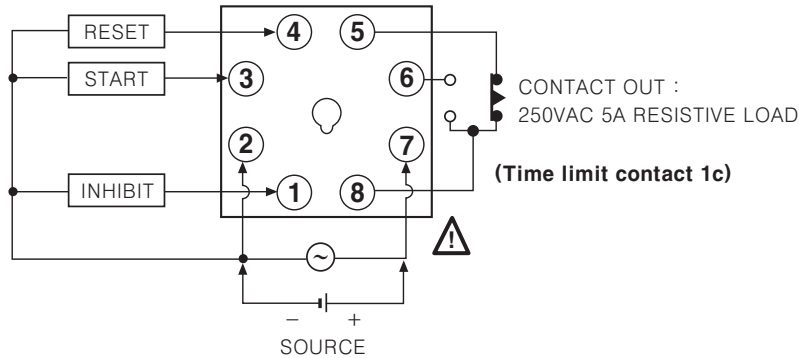

LE4SA

● [ON.D] [ON.D.II] [FK] [FKI] [INT] [T] [T.I] mode

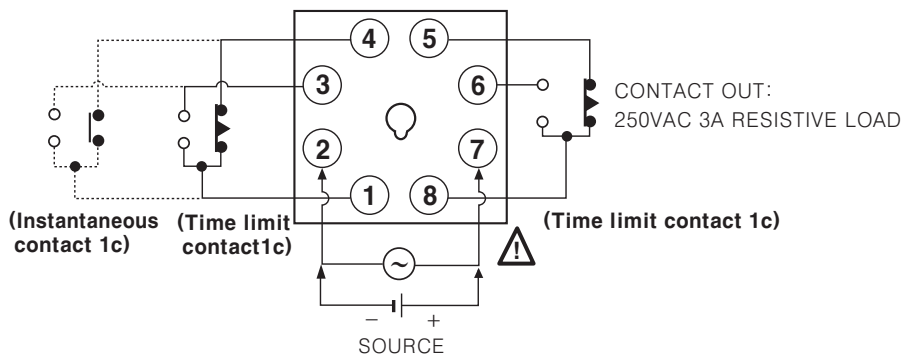

※ Time limit contact 1c + Instantaneous contact 1c or Time limit contact 2c (Selectable)
 ([T] [T.I] : Time limit 2c Only)

● [λ-Δ] mode

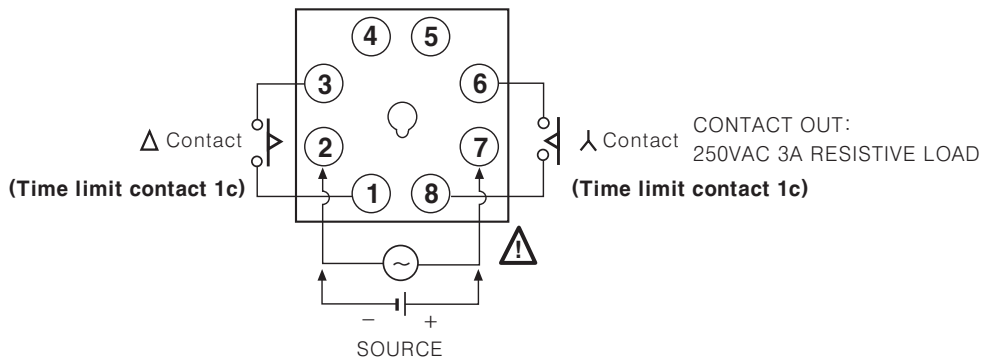

(A)
Counter

(B)
Timer

(C)
Temp.
controller

(D)
Power
controller

(E)
Panel
meter

(F)
Tacho/
Speed/
Pulse
meter

(G)
Display
unit

(H)
Sensor
controller

(I)
Switching
power
supply

(J)
Proximity
sensor

(K)
Photo
electric
sensor

(L)
Pressure
sensor

(M)
Rotary
encoder

(N)
Stepping
motor &
Driver &
Controller

(O)
Graphic
panel

(P)
Field
network
device

(Q)
Production
stoppage
models &
replacement

LE4S Series

Input connections

LE4S is No-voltage input (Short-circuit and open) type.

◎Solid-state input

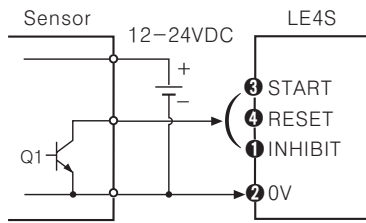

- Q1 is ON : Operating
- Sensor : NPN open collector output
- Short-circuit level (Transistor:ON)
Residual voltage : Max. 1V,
Impedance : Max. 1kΩ
- Open-circuit level (Transistor OFF)
Impedance : Min. 100kΩ

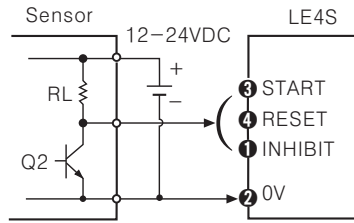

- Q2 is ON : Operating
- Sensor : NPN universal output

◎Contact input

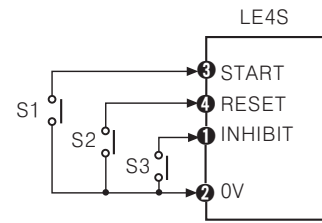

- S1, S2, S3 are ON : Operating
- Please use reliable contact
enough to flow 5VDC 1mA.

※Be sure that it is not insulated between power and input terminal block.

Front panel identification

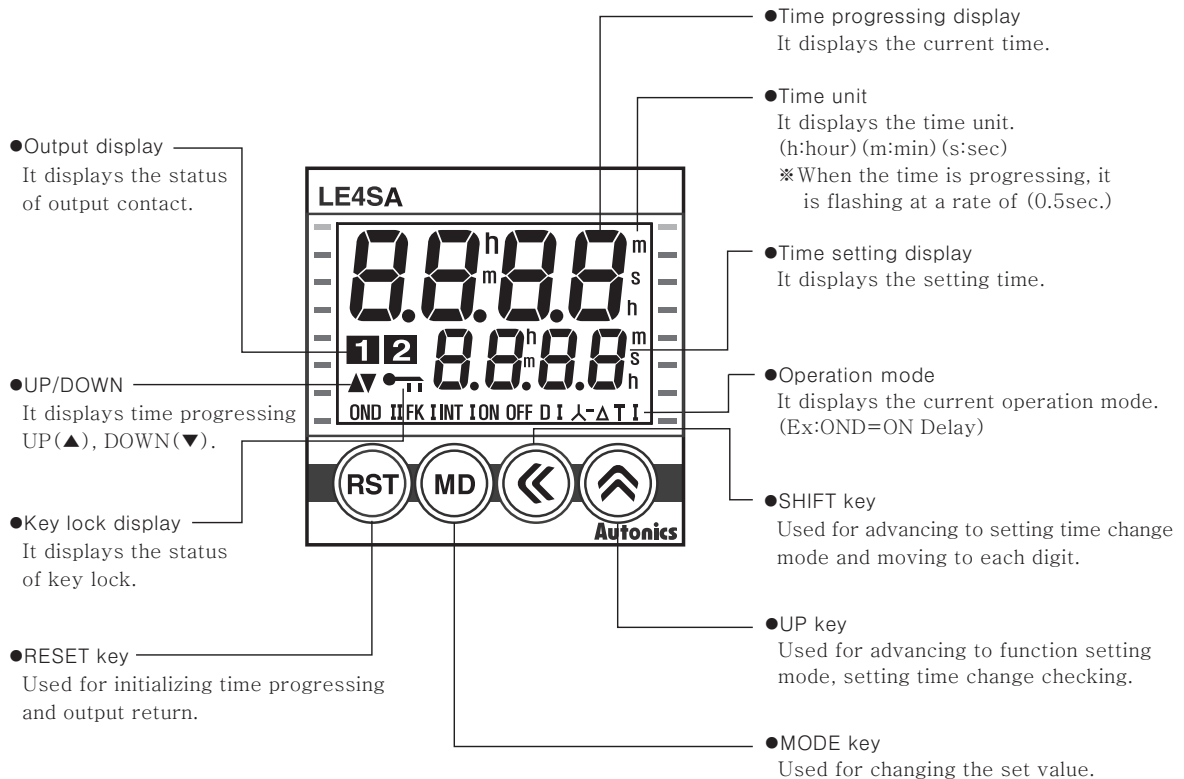

Function and time setting

○ Configuration

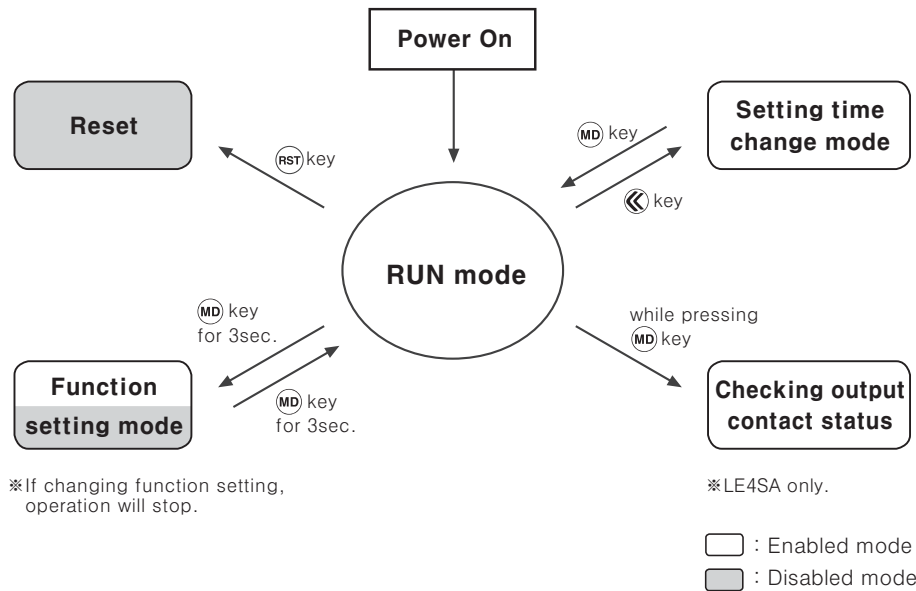

● Reset

Reset using key in Run mode

● Run mode

The operation status (When power is on for the first time: factory default setting) is displayed. It could enter into function setting mode, setting value change mode and output contact status mode.

● Function setting mode

If pressing key over 3 sec. in the Run mode, it will enter into function setting mode and if pressing key over 3 sec. in function setting mode, it will return to Run mode.

※ Even if it enter into function setting mode in Run mode, time progressing and output control will continue.

※ If operation settings are changed in function setting mode, all outputs will be off and reset on returning to run mode.

● Output contact status mode (LE4SA only.)

Output contact status are displayed while pressing key in Run mode.

※ If pressing key over 3 sec., it will enter into function setting mode.

● Setting time change mode

Press key to enter into setting time change mode and press key to return to Run mode.

Even if signal is input when changing setting time, time progressing and output control will be continue.

If no key is pressed over 60 sec. in setting time change mode, it will return to Run mode.

※ If no key is pressed over 60 sec. in setting time change mode, it will return to Run mode and previous parameter value is not stored.

(A) Counter

(B) Timer

(C) Temp. controller

(D) Power controller

(E) Panel meter

(F) Tacho/Speed/Pulse meter

(G) Display unit

(H) Sensor controller

(I) Switching power supply

(J) Proximity sensor

(K) Photo electric sensor

(L) Pressure sensor

(M) Rotary encoder

(N) Stepping motor & Driver & Controller

(O) Graphic panel

(P) Field network device

(Q) Production stoppage models & replacement

LE4S Series

Function setting mode descriptions

LE4S

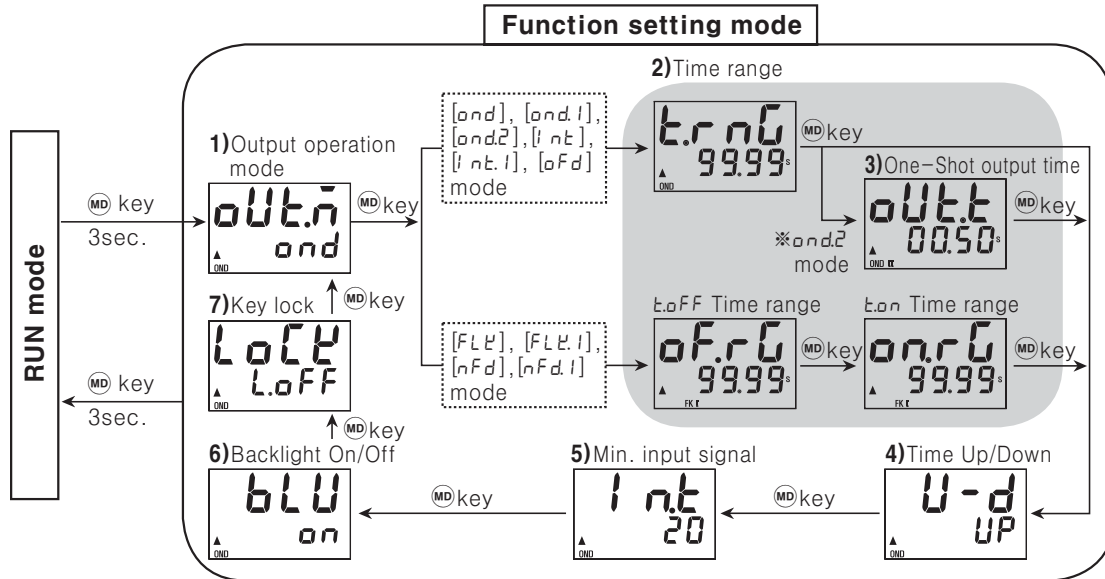

LE4SA

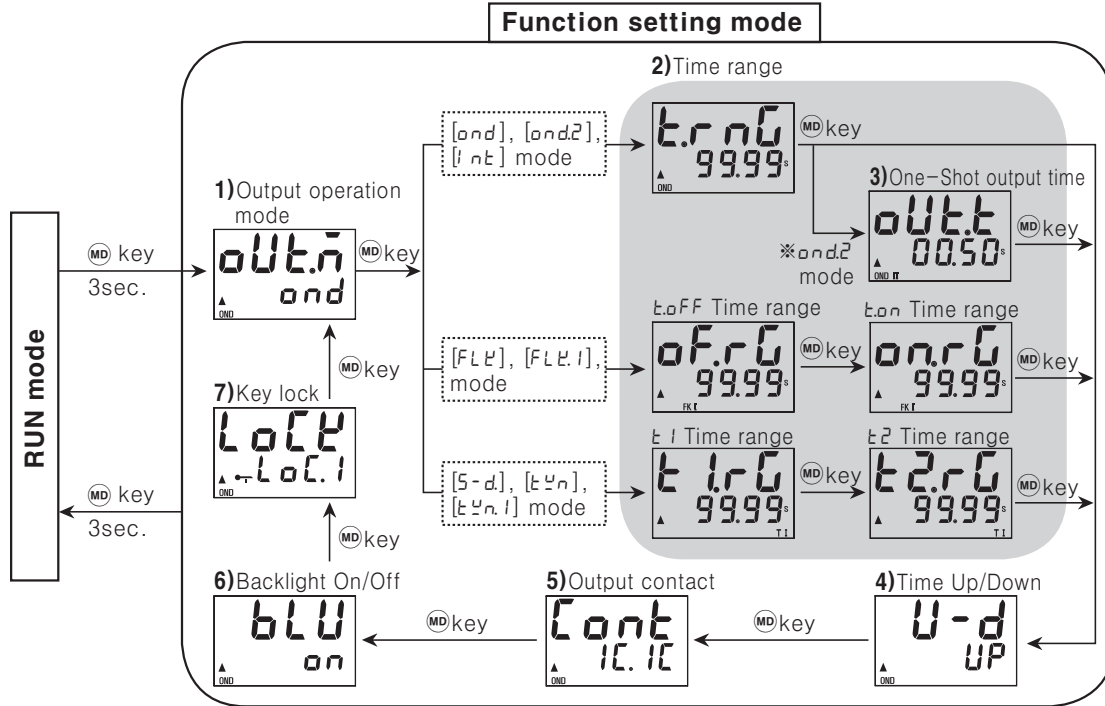

Factory Default setting

LE4S

Parameter	Factory Default setting
Output operation mode	oUt.n ond
Time range	t.r.nG 99.99s
Time Up/Down	U-d UP
Min. input signal	i.n.t 20
Backlight On/Off	bLU on
Key lock	LoCK LoFF
Setting time	- 50.00s

LE4SA

Parameter	Factory Default setting
Output operation mode	oUt.n ond
Time range	t.r.nG 99.99s
Time Up/Down	U-d UP
Output contact	Cont IC.IC
Backlight On/Off	bLU on
Key lock	LoCK LoC.1
Setting time	- 50.00s

Output operation mode

LE4S/LE4SA output operation mode

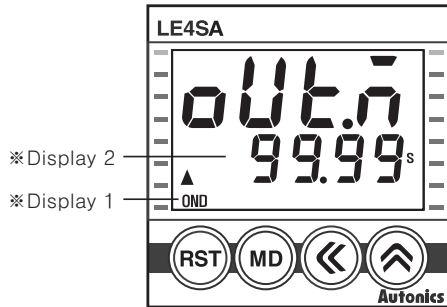

NO	※Display 1	※Display 2	Operation mode	LE4S	LE4SA
1	OND	ond	ON DELAY	○	○
2	OND I	ond.1	ON DELAY 1	○	—
3	OND II	ond.2	ON DELAY 2	○	○
4	FK	FLK	FLICKER	○	○
5	FK I	FLK.1	FLICKER 1	○	○
6	INT	int	INTERVAL	○	○
7	INT I	int.1	INTERVAL 1	○	—
8	ON OFF D	nFd	ON-OFF DELAY	○	—
9	ON OFF D I	nFd.1	ON-OFF DELAY 1	○	—
10	OFF D	oFd	OFF DELAY	○	—
11	λ-Δ	S-d	STAR-DELTA	—	○
12	T	tyn	TWIN	—	○
13	T I	tyn.1	TWIN 1	—	○

Output operation mode

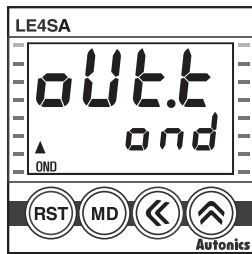

[Fig.1]

- 1) In function setting mode, it enter into output operation mode as shown in the [Fig. 1].
- 2) Select proper output operation mode using ◀ and ▶ key.
(Refer to Output operation flowchart)
- 3) Press MD key to set output operation mode and move to next mode.
- 4) If pressing MD key for 3 sec. in any function setting mode, it will return to Run mode.

Output operation flowchart

< LE4S >

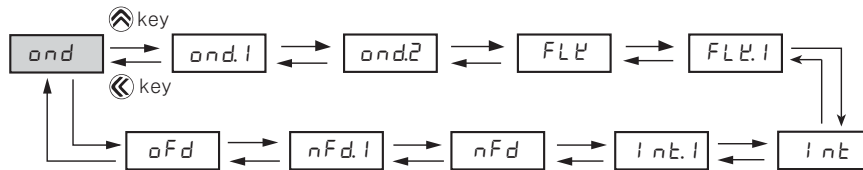

< LE4SA >

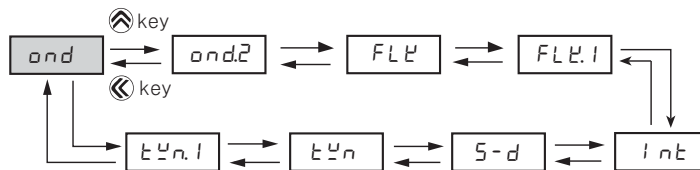

※Shaded part on flowchart is factory default setting.

(A) Counter

(B) Timer

(C) Temp. controller

(D) Power controller

(E) Panel meter

(F) Tacho/ Speed/ Pulse meter

(G) Display unit

(H) Sensor controller

(I) Switching power supply

(J) Proximity sensor

(K) Photo electric sensor

(L) Pressure sensor

(M) Rotary encoder

(N) Stepping motor & Driver & Controller

(O) Graphic panel

(P) Field network device

(Q) Production stoppage models & replacement

LE4S Series

Time Range

Time range specifications

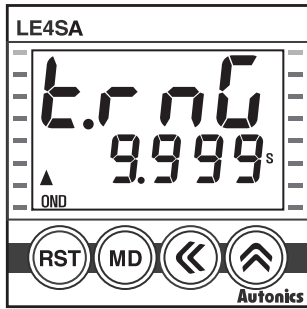

Parameter	Time range specification
9.999s (9.999s)	0.010sec ~ 9.999sec
99.99s (99.99s)	0.01sec ~ 99.99sec
999.9s (999.9s)	0.1sec ~ 999.9sec
9999s (9999s)	1sec ~ 9999sec
99m59s (99m59s)	0m01sec ~ 99min 59sec
999.9m (999.9m)	0.1min ~ 999.9min
9999m (9999m)	1min ~ 9999min
99h59m (99h59m)	0h01min ~ 99hour 59min
99.99h (99.99h)	0.01hour ~ 99.99hour
999.9h (999.9h)	0.1hour ~ 999.9hour
9999h (9999h)	1hour ~ 9999hour

t.oFF Time range

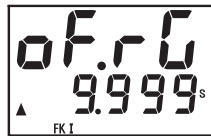

t.oN Time range

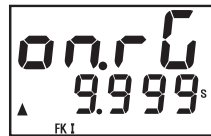

t.1 Time range



t.2 Time range



Time range according to output operation mode

- Time range (t.r.n.G)
: When ond, ond.1, ond.2, i.n.t., i.n.t.1, oFd mode
- t.oFF / t.oN Time range (oF.r.G / oN.r.G)
: When FLt, FLt.1, nFd, nFd.1 mode
- t.1 / t.2 Time range (t.1.r.G / t.2.r.G)
: When S-d, t.Y.n, t.Y.n.1 mode

Time range selection method

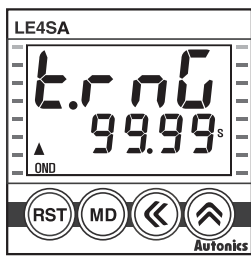

[Fig.1]

When ond, ond.1, ond.2, i.n.t., i.n.t.1, oFd mode

- 1) In function setting mode, if it enter into time range mode, the characters will be displayed as shown in the [Fig. 1].
- 2) Select the time range using ⏪ and ⏩ key.
(Refer to time range flowchart)
- 3) Press MD key to complete the time range setting and the next mode.
- 4) If pressing MD key for 3 sec., it will return to Run mode.

※ When FLt, FLt.1, nFd, nFd.1, S-d, t.Y.n, t.Y.n.1 time range (oF.r.G, oN.r.G or t.1.r.G / t.2.r.G) can be individually set.

Time range flowchart

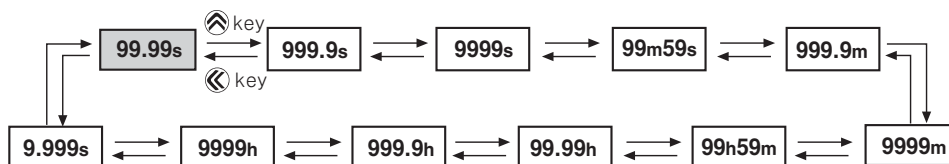

※ Shaded part on flowchart is factory default setting.

●One-Shot output time setting

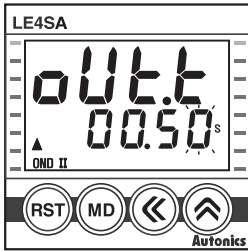

[Fig.2]

※Factory Default setting

When output operation mode ON DELAY 2(ond.2) is set, it is activated.

- 1)In function setting mode, if it enter into One-shot output time setting mode as shown in the [Fig. 2], the last digit will flash.
- 2)Set One-Shot output time using ◀ and ▶ key.(Setting range: 0.01s~99.99s)
- 3)Pressing (MD)key to complete one-shot output time setting and move to the next mode.
- 4)If pressing (MD)key for 3 sec. in any function setting mode, it will return to Run mode.

●Time progress UP/DOWN setting

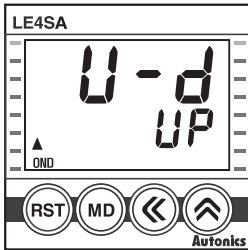

[Fig.3]

※Factory Default setting

- 1)In function setting mode, if it advances to UP/DOWN setting mode, the characters will be displayed as shown in the [Fig. 3].
- 2)Select UP(▲), Dn(▼)using ◀, ▶key.

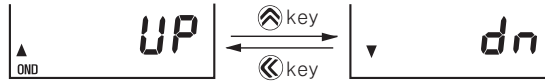

- 3)Press (MD)key to complete UP/DOWN setting and move to the next mode.
- 4)If pressing (MD)key for 3sec. in any function setting mode, it will return to Run mode.

●The minimum input signal setting(LE4S only.)

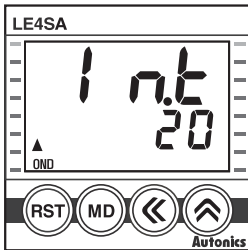

[Fig.4]

※Factory Default setting

Reset, Start and Inhibit.

- 1)In function setting mode, if it enter into input signal setting mode, the characters will be displayed as shown in the [Fig. 4].
- 2)Select 1ms or 20ms using ◀, ▶key

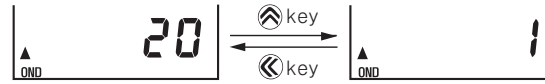

- 3)Press (MD)key to complete input signal width and move to the next mode.
- 4)If Pressing (MD)key over 3 sec. in any function setting mode, it will return to Run mode.

●Output contact setting(LE4SA only.)

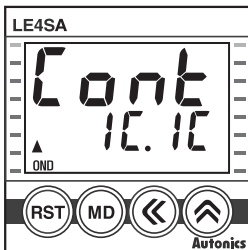

[Fig.5]

※Factory Default setting

- 1)In function setting mode, if it enter into output contact setting mode, the characters will be displayed as shown in the [Fig. 5].
- 2)Select time limit contact 1c+instantaneous contact 1c or time limit contact 2c.
(Refer to LE4SA Connections on B-20 page for output contact connections)

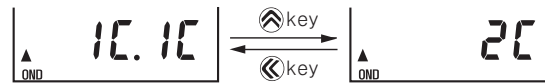

- 3)Press (MD)key to complete output contact setting and move to the next mode.
- 4)If pressing (MD)key for 3 sec. in any function setting, it will return to Run mode.

- ※Except for Star-Delta, Twin and Twin 1 modes(2c is set automatically)
- ※If pressing (MD)key in Run mode, output contact setting value will be displayed.
(If no key is pressed over 3 sec., it will enter into function setting mode.)

(A)
Counter

(B)
Timer

(C)
Temp.
controller

(D)
Power
controller

(E)
Panel
meter

(F)
Tacho/
Speed/
Pulse
meter

(G)
Display
unit

(H)
Sensor
controller

(I)
Switching
power
supply

(J)
Proximity
sensor

(K)
Photo
electric
sensor

(L)
Pressure
sensor

(M)
Rotary
encoder

(N)
Stepping
motor &
Driver &
Controller

(O)
Graphic
panel

(P)
Field
network
device

(Q)
Production
stoppage
models &
replacement

LE4S Series

● Backlight ON/OFF setting

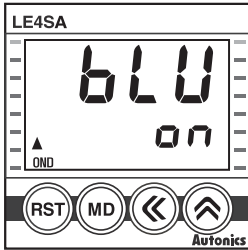

[Fig.6]

※ Factory Default setting

1) In function setting mode, if it enter into Backlight ON/OFF setting mode, the characters will be displayed as shown in the [Fig. 6].

2) Select Backlight ON or OFF using ⏪, ⏩ key.

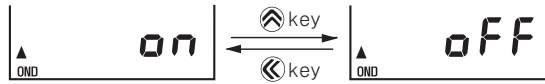

3) Press MD key to complete Backlight ON/OFF setting and move to the next mode.

4) If pressing MD key for 3 sec. in any function setting mode, it will return to Run mode.

● Key Lock setting

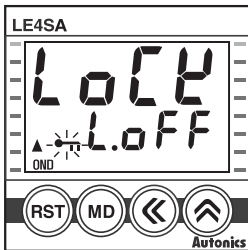

[Fig.7]

※ Factory Default setting

1) In function setting mode, if it enter into Key Lock setting mode, the characters will be displayed as shown in the [Fig. 7].

2) Select LoFF, LoC.1, LoC.2 or LoC.3 using ⏪, ⏩ key.

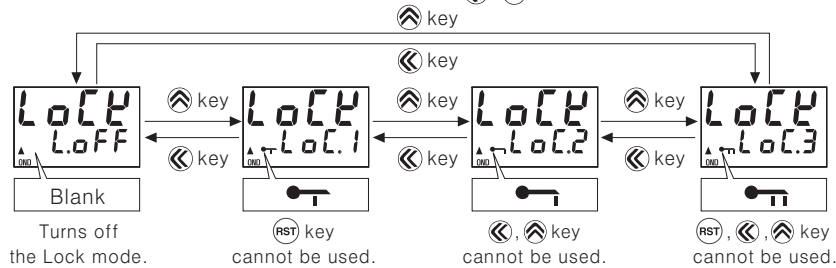

3) Press MD key to complete key lock setting and move to the next mode.

4) If pressing MD key for 3 sec. in any function setting mode, it will return to Run mode.

※ Factory default for LE4S is LoFF and Factory default for LE4SA is LoC.1.

※ Key Lock function

Display	Function
LoFF	Turns off the Key Lock mode.
LoC.1	RST key cannot be used.
LoC.2	⏪, ⏩ key cannot be used.
LoC.3	RST, ⏪, ⏩ key cannot be used.

■ Setting time change

Please set operation time according to following instruction as the setting is different depending on the output operation mode.

● Output operation mode : OND, OND I, OND II, INT, INT I, OFF D

(There is no OND I, INT I, OFF D in LE4SA.)

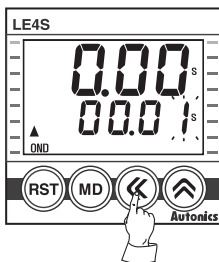

[Fig.1]

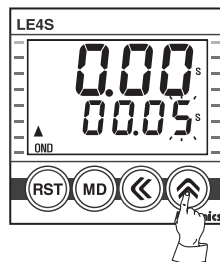

[Fig.2]

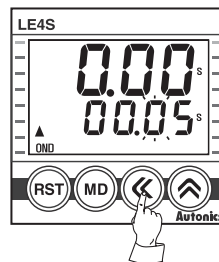

[Fig.3]

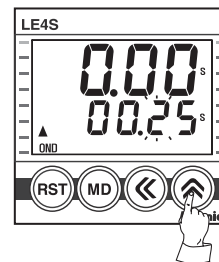

[Fig.4]

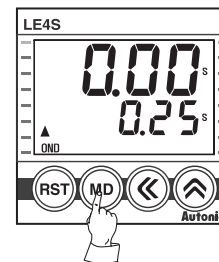

[Fig.5]

1) Press ⏪ key in RUN mode, time set digits will flash. [Fig. 1]

2) Change setting time by using ⏪ or ⏩ keys. [Fig. 2,3,4]

☞ ⏪ key : Shift the setting digits.

☞ ⏩ key : Shift the flashing position value. As press ⏩ key once, it will increase by 1digit, number will increase faster by press ⏩ key for over 2sec.

3) When the setting is completed, it will be stored and return to RUN mode by pressing MD key. [Fig. 5]

Digital LCD Timer

●Output operation mode : FK, FK I

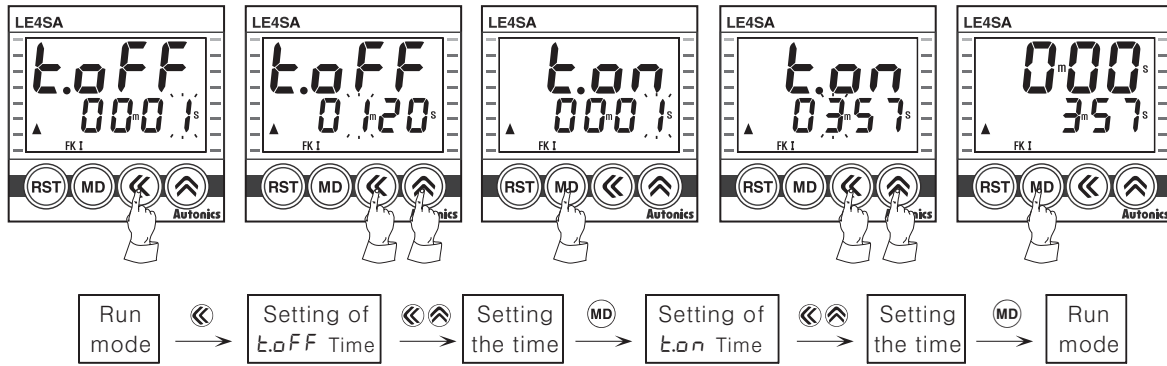

●Output operation mode : ON OFF D, ON OFF D I (LE4S only.)

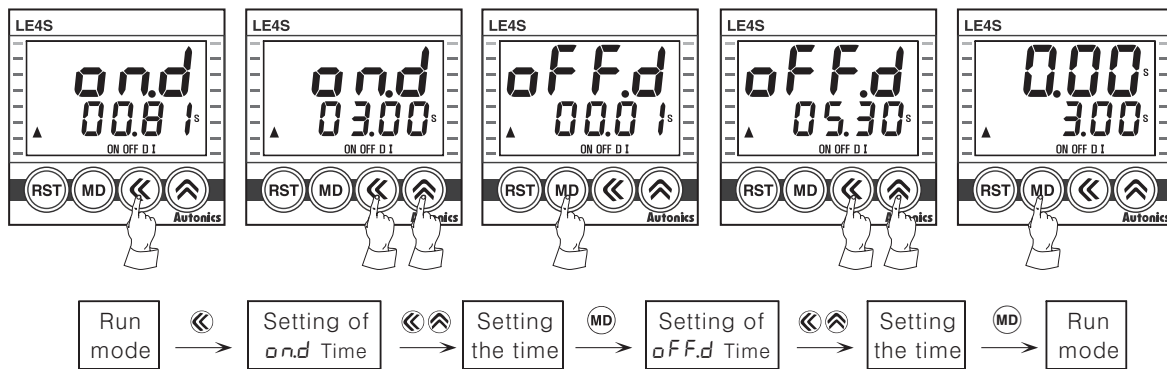

●Output operation mode : λ - Δ , T, T I (LE4SA only.)

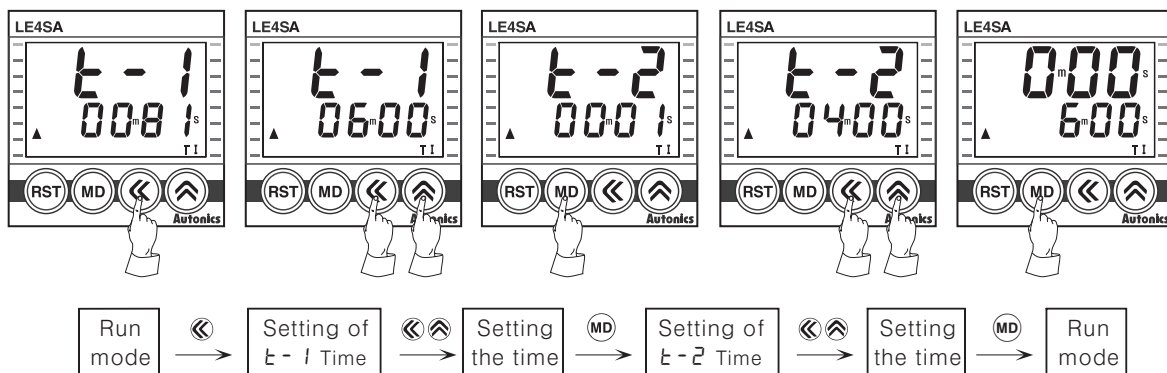

※ It is able to change the setting time during the time progressing, but be sure about the time progressing while changing of the time.

※ If pressing **MD** key while setting time is shorter than min. setting time, setting value will be flickering three times and it will be returned to setting mode again, not to RUN mode.

※ If there is no additional key operations after entering into setting mode, it will be return to RUN mode. (Setting value is not stored.)

※ Min. Setting time : 0.01 sec.

(In case of $on.d$, $on.d.1$ and $on.d.2$ modes, it is able to set "0" since no min. setting time is applied.)

(A) Counter

(B) Timer

(C) Temp. controller

(D) Power controller

(E) Panel meter

(F) Tacho/Speed/Pulse meter

(G) Display unit

(H) Sensor controller

(I) Switching power supply

(J) Proximity sensor

(K) Photo electric sensor

(L) Pressure sensor

(M) Rotary encoder

(N) Stepping motor & Driver & Controller

(O) Graphic panel

(P) Field network device

(Q) Production stoppage models & replacement

LE4S Series

LE4S Output operation mode

T = Setting time, T > Ta

Mode	Time chart	Operation
[ond] OND		
ON-Delay	<ol style="list-style-type: none"> Timing operation starts when START signal is ON at status of power on. Output will be ON when timing operation is progressed up to the setting time. Display value will be HOLD. (① position) When RESET signal is ON, display value and output will be reset. (② position) If RESET signal is OFF while START signal is ON, "STEP 1" will be restarted. (③ position) When START signal is OFF, display value and output will be reset. (④ position) 	T = Setting time
T > Ta		
[ond.1] OND I		
ON-Delay 1	<ol style="list-style-type: none"> Timing operation starts when START signal is ON at status of power on. Output will be ON when timing operation is progressed up to the setting time. Display value will be HOLD. (① position) Even though START signal is applied repeatedly, only the initial signal is recognized. (② position) When RESET signal is ON, display value and output will be reset. (③ position) 	T = Setting time
T > Ta		
[ond.2] OND II		
ON-Delay 2 (One-Shot Output)	<ol style="list-style-type: none"> Timing operation starts when START signal is ON at status of power on. Time limit output will be ON and goes OFF during Tout setting time when timing operation is progressed up to the setting time. Display value will be HOLD. (① position) When RESET signal is ON, display value and output will be reset. If START signal is applied while time is progressing, Timing operation will be reset and started again. (② position) Tout setting range: 0.01 sec~99.99 sec. 	Tout = Output time T = Setting time
T > Ta		
[FLF] FK		
Flicker (Toff operation precedes Ton operation)	<ol style="list-style-type: none"> If START signal is ON, output will be repeatedly OFF during Toff setting time and will be OFF during Ton setting time when power is ON. When RESET signal is ON, display value and output will be reset. If RESET signal is OFF when START signal is ON, "STEP 1" will be restarted. When START signal is OFF, display value and output will be reset. It is able to set each Toff time and Ton time separately. In [FLF] mode, timing operation starts with Toff. 	Ton, Toff = Setting time Able to set Ton and Toff time differently.
Ton, Toff > Ta		
[FLF.1] FK. I		
Flicker 1 (Ton operation precedes Toff operation)	<ol style="list-style-type: none"> If START signal is ON, output will be repeatedly ON during Ton setting time and will be OFF during Toff setting time when power is ON. Even though START signal is applied repeatedly, only the initial signal is recognized. (① position) When START signal is ON, display value and output will be reset. If START signal is ON, it will be restarted. It is able to set each Toff time and Ton time separately. In [FLF.1] mode, timing operation starts with Ton. 	Ton, Toff = Setting time Able to set Ton and Toff time differently.
Ton, Toff > Ta		

*Initial status : UP mode—display value is "0", output is "OFF".

DOWN mode—display value is "setting time", output is "OFF".

Digital LCD Timer

LE4S Output operation mode

T = Setting time, T > Ta

Mode	Time chart	Operation
[INT] Interval	<p>1. Output will be ON when START signal is ON at status of power on and Timing operation starts. 2. Output will be OFF when timing operation is progressed up to the setting time. Display value will be HOLD. 3. When RESET signal is ON, display value and output will be reset. (① position) 4. If RESET signal is OFF when START signal is ON, "STEP 1" will be restarted. 5. When STRAT signal is OFF, display value and output will be reset. (② position)</p>	<p>T = Setting time</p>
[INT.1] Interval 1	<p>1. Output will be ON when START signal is ON at status of power on and Timing operation starts. 2. Output will be OFF when timing operation is progressed up to the setting time. Display value will be HOLD. 3. Even though START signal is applied repeatedly, only the initial signal is recognized. (① position) 4. If START signal is ON after timing operation is progressed up to the setting time, Output will be ON and setting time will be reset and then timing setting starts. 5. When RESET signal is ON, display value and output will be reset. (② position)</p>	<p>T = Setting time</p>
[nFd] ON OFF Delay	<p>1. If START signal is ON when power is on, Output will be ON when timing operation is progressed up to the Ton setting time(On-Delay). IF START signal is OFF, output will be ON when timing operation is progressed up to the Toff setting time (OFF-Delay). 2. If START signal is applied repeatedly, output is ON and display value will be reset. (① position) 3. When RESET signal is ON, display value and output will be reset. When RESET signal is OFF while START signal is ON, it will be operating as On-Delay. (② position) 4. It is able to set each Toff time and Ton time separately.</p>	<p>Ton, Toff = Setting time</p>
[nFd.1] ON OFF Delay 1	<p>1. If START signal is ON when power is on, timing operation starts. Output will be ON when timing operation is progressed up to the Ton setting time(On-Delay). IF START signal is OFF, output will be ON when timing operation is progressed up to the Toff setting time (OFF-Delay). 2. Output will be ON when START signal is ON and goes OFF during setting time and display value will be reset. (① position) 3. Output will be OFF when START signal is OFF and goes ON during setting time and display value will be reset. (① position) 4. When RESET signal is ON, display value and output will be reset. When RESET signal is OFF while START signal is ON, it will be operating as On-Delay. (② position) 5. It is able to set each Toff time and Ton time separately.</p>	<p>Ton, Toff = Setting time</p>
[oFd] OFF Delay	<p>1. If START signal is ON when power is on, output will be ON. 2. When START signal is OFF, timing operation starts. Output will be OFF when timing operation is progressed up to the setting time. Display value will be HOLD. 3. When RESET signal is ON, display value and output will be reset.</p>	<p>T = Setting time</p>

*Initial status : UP mode—display value is "0", output is "OFF". DOWN mode—display value is "setting time", output is "OFF".

(A) Counter

(B) Timer

(C) Temp. controller

(D) Power controller

(E) Panel meter

(F) Tacho/Speed/Pulse meter

(G) Display unit

(H) Sensor controller

(I) Switching power supply

(J) Proximity sensor

(K) Photo electric sensor

(L) Pressure sensor

(M) Rotary encoder

(N) Stepping motor & Driver & Controller

(O) Graphic panel

(P) Field network device

(Q) Production stoppage models & replacement

LE4S Series

LE4SA Output operation mode

T = Setting time, T > Ta, Rt = Reset time

Mode	Time chart	Operation
[ond] OND ON Delay		<p>T = Setting time</p>
[ond2] OND II ON Delay 2 (One-Shot Output)		<p>Tout = Output time T = Setting time</p>
[FLF] FK Flicker (Toff operation precedes Ton operation)		<p>Ton, Toff = Setting time</p> <p>Able to set T-ON and T-OFF time differently.</p>
[FLF1] FK I Flicker 1 (Ton operation precedes Toff operation)		<p>T = Setting time</p>

*Initial status : UP mode—display value is "0", output is "OFF".

DOWN mode—display value is "setting time", output is "OFF".

*Instantaneous contact (OUT2) will be returned when power is off.

*RESET key is locked for default set and release the lock to use.

Digital LCD Timer

LE4SA Output operation mode

Rt : Reset time (Min. 500ms)

Mode	Time chart	Operation
[Interval] Mode: [Interval] INT Interval		<p>T = 설정시간</p>
[Star-Delta] Mode: [Star-Delta] λ - Δ Star-Delta (Output will be set automatically as Time limit 2c)		<p>※T1 : Setting time T2 : Return time (λ - Δ Return time)</p>
[Twin] Mode: [Twin] T Twin (Output will be set automatically as Time limit 2c)		<p>T1, T2 = Setting time</p> <p>Able to set T1 and T2 time differently.</p>
[Twin 1] Mode: [Twin 1] T1 Twin 1 (Output will be set automatically as Time limit 2c) T1, T2 > Ta		<p>T1, T2 = Setting time</p> <p>Able to set T1 and T2 time differently.</p>

※Initial status : UP mode—display value is "0", output is "OFF".

DOWN mode—display value is "setting time", output is "OFF".

※Instantaneous contact (OUT2) will be returned when power is off.

※RESET key is locked for default set and release the lock to use.

(A) Counter

(B) Timer

(C) Temp. controller

(D) Power controller

(E) Panel meter

(F) Tacho/ Speed/ Pulse meter

(G) Display unit

(H) Sensor controller

(I) Switching power supply

(J) Proximity sensor

(K) Photo electric sensor

(L) Pressure sensor

(M) Rotary encoder

(N) Stepping motor & Driver & Controller

(O) Graphic panel

(P) Field network device

(Q) Production stoppage models & replacement

LE4S Series

■ Proper usage

⚠ Caution

It may give an electric shock if touch the input signal terminal (Between START, RESET, INHIBIT and terminal ②) when the power is supplied.

◎ Power connection

- Connect AC power line between (②-⑦) for LE4S, LE4SA AC power type. Be careful of power connection for DC power type. (② ← ⊖, ⑦ ← ⊕)
- LE4S, LE4SA work stably within range of rated power. (If using power line with another high voltage line or energy line in the same conduit, it may cause inductive voltage. Therefore please use separate conduit for power line)

◎ Power start

- Caution for power rising time (100ms) after power on and power falling time (100ms) after power off.

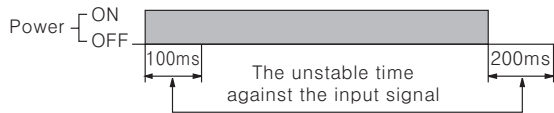

- Power start

LE4SA model is starting after 100ms of applying power (Refer to the above figure.)

(Please use over 100ms setting)

When you need under 100ms setting, please use Signal start type LE4S.

- Please supply power quickly as using switch or relay contact, otherwise it may cause timing error.

◎ Input/Output

- Power terminal and Input terminal have not been insulated because there is no power transformer in this Timer.

① When using the sensor of SSR output type with input terminal of timer, please check whether Double insulated or not.

② Please use double insulated relay when connecting relay output with input terminal.

- Please use 8 Pin socket when connecting this Timer with other equipment and do not touch the socket when power on.
- Please use Power supply with over current protection circuit. (250V 1A fuse)
- When using relay contact as input signal, please use a contact that can function reliable at 5VDC, 1mA.

- In case of connecting START terminal (③) and power terminal (②) of LE4S, do not use it to start at the same time applying power.

Please use relay contact or transistor to start.

(Time error can be occurred under 100ms setting because of rising time of Timer).

- LE4S is Transformer Less type, therefore please check following for connecting relay contact for input signal and transistor.

① When connecting more than 2 Timers with 1 relay contact for input or transistor, please wire following <Fig. 2 >.

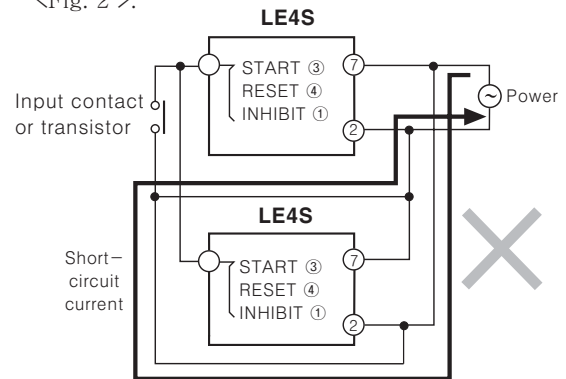

< Fig. 1 >

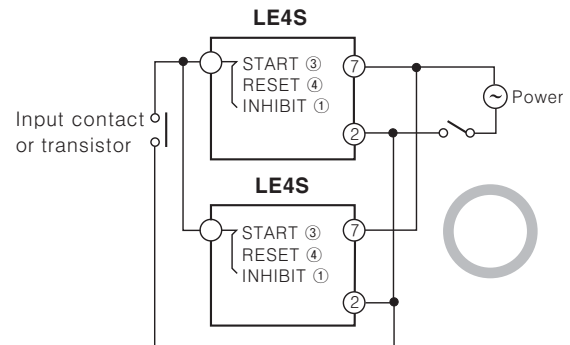

< Fig. 2 >

- ② Please use transformer with primary and secondary isolated for input.

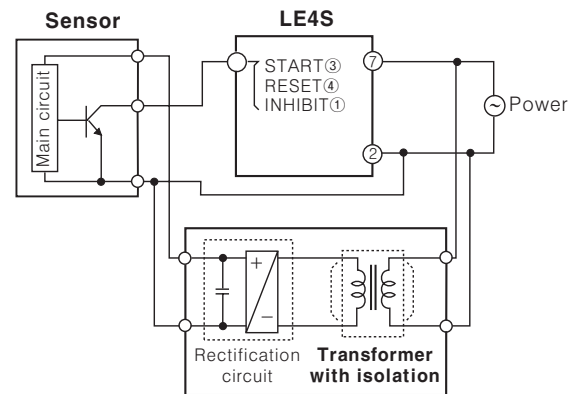

< External sensor power supply >

- Please supply power to LE4SA after checking operation specification.
- If setting 「0000」 for operation time, output may not work.

◎Interval mode

Able to make Instantaneous ON and Time limit OFF (Holding device) with using interval mode.

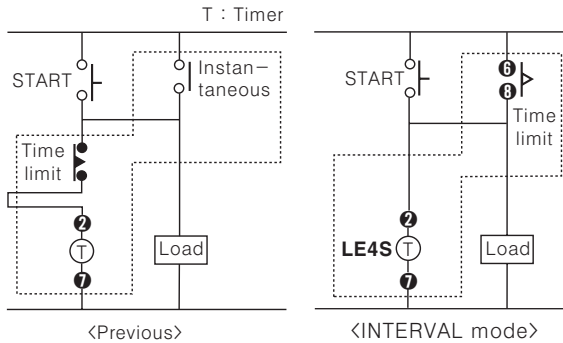

◎Change of output operation mode and Timer range

If changing output operation mode or Time range, previous PRESET value will be deleted.

But, Up/Down selection mode and Lock mode are exception.

◎Change of preset value

- If changing setting value while time progressing, new preset value should be higher than previous preset value. Otherwise output may work while changing setting value.
- If changing setting value while it is running, it will work as changed setting value. Please use LOCK function in order to avoid malfunction.

◎Noise

We test 2kV, pulse width 1 μ s against Impulse voltage between power terminals and 1kV, Pulse width 1 μ s at noise simulator against external noise voltage. Please install MP condensor (0.1~1 μ F) or Oil condensor between power teminals when over IMPULSE noise voltage occurs.

◎Environment

Please avoid the following places;

- Where this product may be damaged by strong impact or vibration.
- Where there are corrosive gas or flammable gas and water, oil, dust exist.
- Where magnetic and electrical noise occurs.
- Where there are high temperature and humidity beyond rated specification.
- Where there are strong alkalis and acids.
- Where there are direct rays of sun.

(A)
Counter

(B)
Timer

(C)
Temp.
controller

(D)
Power
controller

(E)
Panel
meter

(F)
Tacho/
Speed/
Pulse
meter

(G)
Display
unit

(H)
Sensor
controller

(I)
Switching
power
supply

(J)
Proximity
sensor

(K)
Photo
electric
sensor

(L)
Pressure
sensor

(M)
Rotary
encoder

(N)
Stepping
motor &
Driver &
Controller

(O)
Graphic
panel

(P)
Field
network
device

(Q)
Production
stoppage
models &
replacement