

THREAD FIXING UNITS

3001

Features: Adjustable height, drilled hole fixing.
Optional extras: Additional nuts, alternative thread sizes, dirt exit hole.

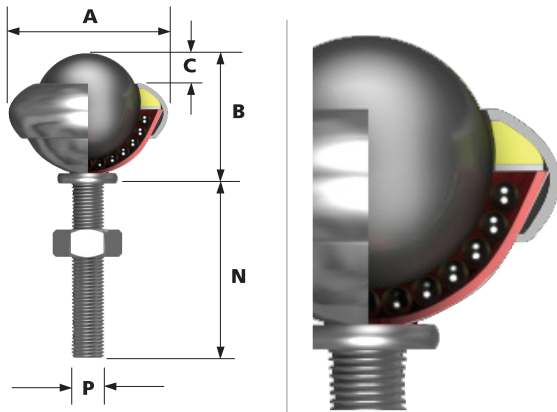

3002

Features: Large support area, greater stability, drilled hole fixing.
Optional extras: Alternative thread sizes, dirt exit hole.

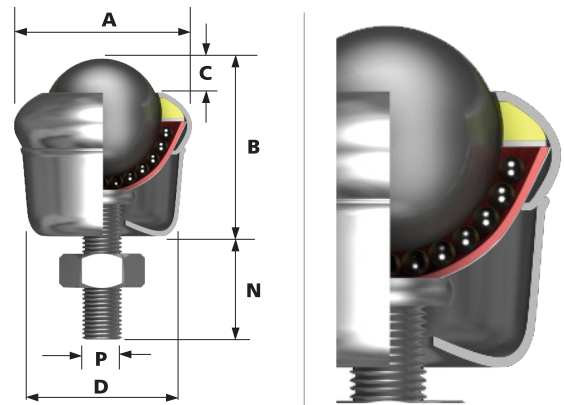

1003

Features: Large support area, greater stability, drilled hole fixing.
Optional extras: Alternative thread sizes, dirt exit hole.

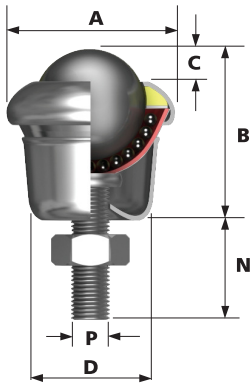

1009

Features: Adjustable height, drilled hole fixing.
Optional extras: Additional nuts, alternative thread sizes, dirt exit hole.

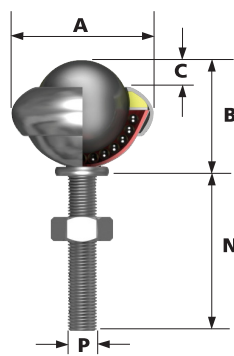

1501

Features: Large support area, greater stability, drilled hole fixing. High load capacity, plastic knife edge seal on main ball.
Optional extras: Alternative thread sizes, dirt exit hole.

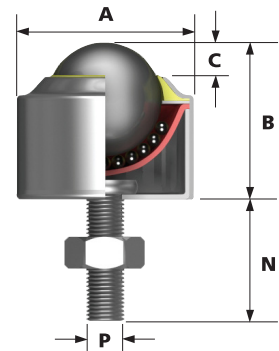

2001

Features: Adjustable height, drilled hole fixing.
Optional extras: Additional nuts, alternative thread sizes, dirt exit hole.

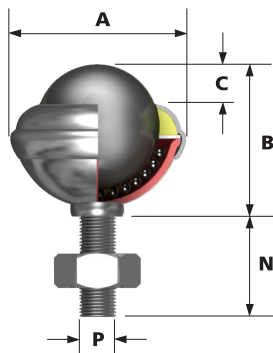

2005

Features: Large support area, greater stability, drilled hole fixing.
Optional extras: Alternative thread sizes, dirt exit hole.

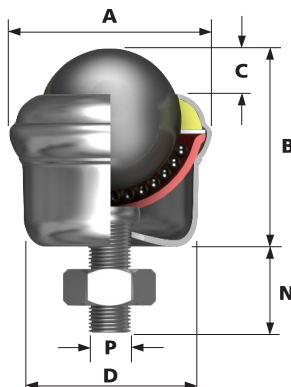

4004

Features: Adjustable height, drilled hole fixing. High load capacity, dirt exit hole. Can be dismantled for cleaning.
Optional extras: Grease points can be fitted. Alternative thread sizes.

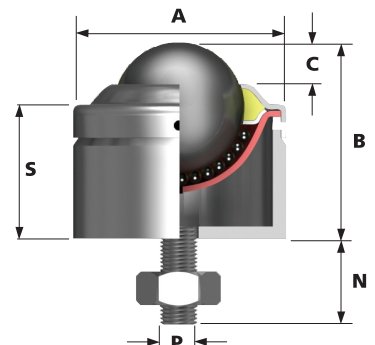

REF No.	BALL SIZE (mm)	MAX TORQUE on NUT (Nm)	WEIGHT (KGS)	DIMENSIONS (mm)						MAXIMUM DYNAMIC LOADING (kg)							
				A	B	C	D	N	P	TYPE 13 Carbon Steel Bearings, Zinc Plated Pressings		TYPE 14 Nylon Load Bearing, Zinc Plated Pressings		TYPE 15 Stainless Steel Bearings and Pressings		TYPE 16 Stainless Steel Bearings, Zinc Plated Pressings	
				Max Diameter	Working Height of Ball	Ball Exposure above Outer Ring	Body Diameter	Length of Thread	Thread Sizes	LOAD UP	LOAD DOWN	LOAD UP	LOAD DOWN	LOAD UP	LOAD DOWN	LOAD UP	LOAD DOWN

3001	19	15	0.060	32.1	24.6	4.7	-	25 30 35 40 50	M8	25	10	20	10	25	10	25	10
3002			0.080		30.2		25.4	18 23 28 33 43									

Ball units are also available with black phenolic load balls (see page 3 suffix PB) of Ø19mm and Ø25.4mm. Ball transfer units assembled with a black phenolic load ball can be used for glass handling applications.

1003	25.4	15	0.160	39.7	6.3	25.4	18 23 28 33 43	M8	55	25	25	10	55	25	55	25
1009			0.140				32.5									
1501			0.180	39.5	35.8	6.1	-									

*Pattern 4004 can be supplied with other screw sizes or plain shanks.

REF No.	BALL SIZE (mm)	MAX TORQUE on NUT (Nm)	WEIGHT (KGS)	DIMENSIONS (mm)							MAXIMUM DYNAMIC LOADING (kg)							
				A	B	C	D	N	P*	S	TYPE 13 Carbon Steel Bearings, Zinc Plated Pressings		TYPE 14 Nylon Load Bearing, Zinc Plated Pressings		TYPE 15 Stainless Steel Bearings and Pressings		TYPE 16 Stainless Steel Bearings, Zinc Plated Pressings	
				Max Diameter	Working Height of Ball	Ball Exposure above Outer Ring	Body Diameter	Length of Thread	Thread sizes	Base to top of body	LOAD UP	LOAD DOWN	LOAD UP	LOAD DOWN	LOAD UP	LOAD DOWN	LOAD UP	LOAD DOWN

2001	39.7	20	0.400	55.5	47.62	11.9	-	25 30 40 50	M10	-	140	60	N/A	N/A	140	60	140	60
2005			0.460	55.5	54.8		49	22 32 42										
4004	50.8	25	1.720	89	76	14.3	-	UPTO 75	5/8" Whit M16	53.8	340	100	N/A	N/A	250	100	340	100

To order, specify REF N°, TYPE and LENGTH OF THREAD, i.e. 3001-13-25.

General Tolerance unless stated ±0.3mm

