

mm inch

RoHS Directive compatibility information
<http://www.nais-e.com/>

FEATURES

- High contact capacity with superior inrush current characteristics;

	1 Form A	2 Form A
Rating	30 A 277 V AC	25 A 277 V AC
TV rating	TV-15	TV-10

- Excellent high heat-resistance;
- High dielectric strength: 10,000 V surge Conforming to VDE0806 (Insulation gap: 8 mm .315 inch) VDE, TÜV also approved

SPECIFICATIONS

Contacts

Type	DC coil type		AC coil type		
Arrangement	1a	2a	1a	2a	
Contact material	AgSnO ₂ type				
Initial contact resistance, max. (By voltage drop 6 V DC 1A)	100 mΩ				
Rating (resistive)	Nominal switching capacity	30 A 277 V AC	25 A 277 V AC	30 A 277 V AC	25 A 277 V AC
	Max. switching power	8,310 VA	6,925 VA	8,310 VA	6,925 VA
	Max. switching voltage	277 V AC, 30 V DC			
	Max. switching current	30 A	25 A	30 A	25 A
	Min. switching capacity ^{#1}	100 mA, 5 V DC			
Expected life (min. operations)	Mechanical (at 180 cpm)	10 ⁷		5×10 ⁶	
	Electrical (at 20 cpm)	10 ⁵ (1a: 30 A 277 V AC, 2a: 25 A 277 V AC) 2×10 ⁵ (1a: 30 A 250 V AC, 2a: 20 A 250 V AC)			

Coil (at 20°C 68°F)

	DC coil type	AC coil type
Nominal operating power	1.92 W	See Coil data (next page)

#1 This value can change due to the switching frequency, environmental conditions, and desired reliability level, therefore it is recommended to check this with the actual load.

Remarks

- * Specifications will vary with foreign standards certification ratings.
- *1 Measurement at same location as "initial breakdown voltage" section
- *2 Detection current: 10 mA
- *3 Wave is standard shock voltage of ±1.2×50μs according to JEC-212-1981
- *4 Excluding contact bounce time
- *5 Half-wave pulse of sine wave: 11ms; detection time: 10μs
- *6 Half-wave pulse of sine wave: 6ms
- *7 Detection time: 10μs
- *8 Refer to 6. Conditions for operation, transport and storage mentioned in AMBIENT ENVIRONMENT).

Characteristics

	DC coil type	AC coil type
Maximum operating speed	20 cpm	
Initial insulation resistance*1	Min. 1,000 MΩ at 500 V DC	
Initial breakdown voltage*2	Between open contacts	2,000 Vrms for 1 min.
	Between contacts and coil	5,000 Vrms for 1 min.
	Between contact sets (2a)	4,000 Vrms for 1 min.
Surge voltage between coil and contact*3	Min. 10,000 V	
Operate time*4 (at nominal voltage)	Max. 30 ms	
Release time*4 (at nominal voltage)	Max. 10 ms	Max. 30 ms
Temperature rise, max. (resistive load)(at 55°C)	60°C	65°C
Shock resistance	Functional*5	98 m/s ² {10 G}
	Destructive*6	980 m/s ² {100 G}
Vibration resistance	Functional*7	10 to 55 Hz at double amplitude of 1 mm
	Destructive	10 to 55 Hz at double amplitude of 1.5 mm
Conditions for operation, transport and storage*8 (Not freezing and condensing at low temperature)	Ambient temp.	-50°C to +55°C -58°F to +131°F
	Humidity	5 to 85% R.H.
	Air pressure	86 to 106 kPa
Unit weight	Approx. 90 g 3.17 oz (Plug-in type)	

TYPICAL APPLICATIONS

- Home appliances
 - Air conditioners
 - Microwave ovens
 - TV sets
 - Heaters
 - Stereo
- Office equipment
 - Copiers
 - Vending machines

ORDERING INFORMATION

Contact arrangement	Pick-up voltage	Terminals	Coil voltage
1a: 1 Form A 2a: 2 Form A	N: 70% of nominal voltage	Nil: Plug-in terminal type S: Screw terminal type SW: Screw terminal type (wide pitch) Q: NEMA terminal type P: PC board terminal type*	DC: 6, 12, 24, 48, 110 V AC: 12, 24, 48, 120, 240 V

Standard packing: Carton: 20 pcs.; Case: 100 pcs.
* PC board terminal are available only for 1 Form A type of DC coil voltage.
UL/CSA, TÜV approved type is standard.

TYPES

	Terminal shape	Contact arrangement	
		1 Form A	2 Form A
DC type	Plug-in terminal	HE1aN-DC6V	HE2aN-DC6V
		HE1aN-DC12V	HE2aN-DC12V
		HE1aN-DC24V	HE2aN-DC24V
		HE1aN-DC48V	HE2aN-DC48V
		HE1aN-DC110V	HE2aN-DC110V
	Screw terminal	HE1aN-S-DC6V	HE2aN-S-DC6V
		HE1aN-S-DC12V	HE2aN-S-DC12V
		HE1aN-S-DC24V	HE2aN-S-DC24V
		HE1aN-S-DC48V	HE2aN-S-DC48V
		HE1aN-S-DC110V	HE2aN-S-DC110V
	Screw terminal (wide pitch)	HE1aN-SW-DC6V	HE2aN-SW-DC6V
		HE1aN-SW-DC12V	HE2aN-SW-DC12V
		HE1aN-SW-DC24V	HE2aN-SW-DC24V
		HE1aN-SW-DC48V	HE2aN-SW-DC48V
		HE1aN-SW-DC110V	HE2aN-SW-DC110V
	NEMA terminal	HE1aN-Q-DC6V	HE2aN-Q-DC6V
		HE1aN-Q-DC12V	HE2aN-Q-DC12V
		HE1aN-Q-DC24V	HE2aN-Q-DC24V
		HE1aN-Q-DC48V	HE2aN-Q-DC48V
		HE1aN-Q-DC110V	HE2aN-Q-DC110V
PC board terminal	HE1aN-P-DC6V	—	
	HE1aN-P-DC12V	—	
	HE1aN-P-DC24V	—	
	HE1aN-P-DC48V	—	
		HE1aN-P-DC110V	—

	Terminal shape	Contact arrangement	
		1 Form A	2 Form A
AC type	Plug-in terminal	HE1aN-AC12V	HE2aN-AC12V
		HE1aN-AC24V	HE2aN-AC24V
		HE1aN-AC48V	HE2aN-AC48V
		HE1aN-AC120V	HE2aN-AC120V
		HE1aN-AC240V	HE2aN-AC240V
	Screw terminal	HE1aN-S-AC12V	HE2aN-S-AC12V
		HE1aN-S-AC24V	HE2aN-S-AC24V
		HE1aN-S-AC48V	HE2aN-S-AC48V
		HE1aN-S-AC120V	HE2aN-S-AC120V
		HE1aN-S-AC240V	HE2aN-S-AC240V
	Screw terminal (wide pitch)	HE1aN-SW-AC12V	HE2aN-SW-AC12V
		HE1aN-SW-AC24V	HE2aN-SW-AC24V
		HE1aN-SW-AC48V	HE2aN-SW-AC48V
		HE1aN-SW-AC120V	HE2aN-SW-AC120V
		HE1aN-SW-AC240V	HE2aN-SW-AC240V
	NEMA terminal	HE1aN-Q-AC12V	HE2aN-Q-AC12V
		HE1aN-Q-AC24V	HE2aN-Q-AC24V
		HE1aN-Q-AC48V	HE2aN-Q-AC48V
		HE1aN-Q-AC120V	HE2aN-Q-AC120V
		HE1aN-Q-AC240V	HE2aN-Q-AC240V

COIL DATA at 20°C 68°F

	Nominal voltage	Pick-up voltage, V DC (max.)	Drop-out voltage, V DC (min.)	Nominal coil current, mA (±10%)	Coil resistance, Ω (±10%)	Nominal operating power, W	Max. allowable voltage (at 50°C 122°F), V DC
DC coil type	6 V DC	4.2	0.6	320.9	18.8	1.92	6.6
	12 V DC	8.4	1.2	160	75	1.92	13.2
	24 V DC	16.8	2.4	80	300	1.92	26.4
	48 V DC	33.6	4.8	40	1200	1.92	52.8
	110 V DC	77.0	11.0	17.5	6300	1.92	121.0

	Nominal voltage	Pick-up voltage, V AC (max.)	Drop-out voltage, V AC (min.)	Nominal coil current, mA (±10%)	Coil resistance, Ω (±10%)	Nominal operating power, VA	Max. allowable voltage (at 50°C 122°F), V AC
AC coil type	12 V AC	8.4	1.8	138*	75	1.7	13.2
	24 V AC	16.8	3.6	74*	300	1.8	26.4
	48 V AC	33.6	7.2	39*	1200	1.9	52.8
	120 V AC	70.0	18.0	22.1*	5200	2.7	132.0
	240 V AC	140.0	36.0	10.8*	20800	2.6	264.0

*Value at 60 Hz

DIMENSIONS

1. Plug-in terminal type

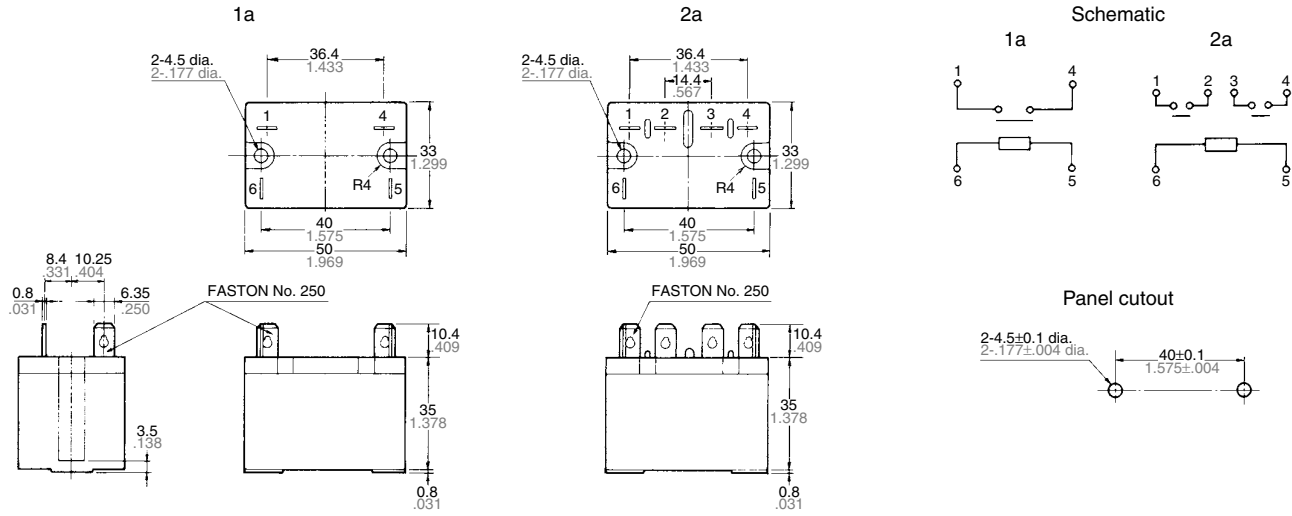

General tolerance: $\pm 0.3 \pm 0.012$

2. NEMA terminal type

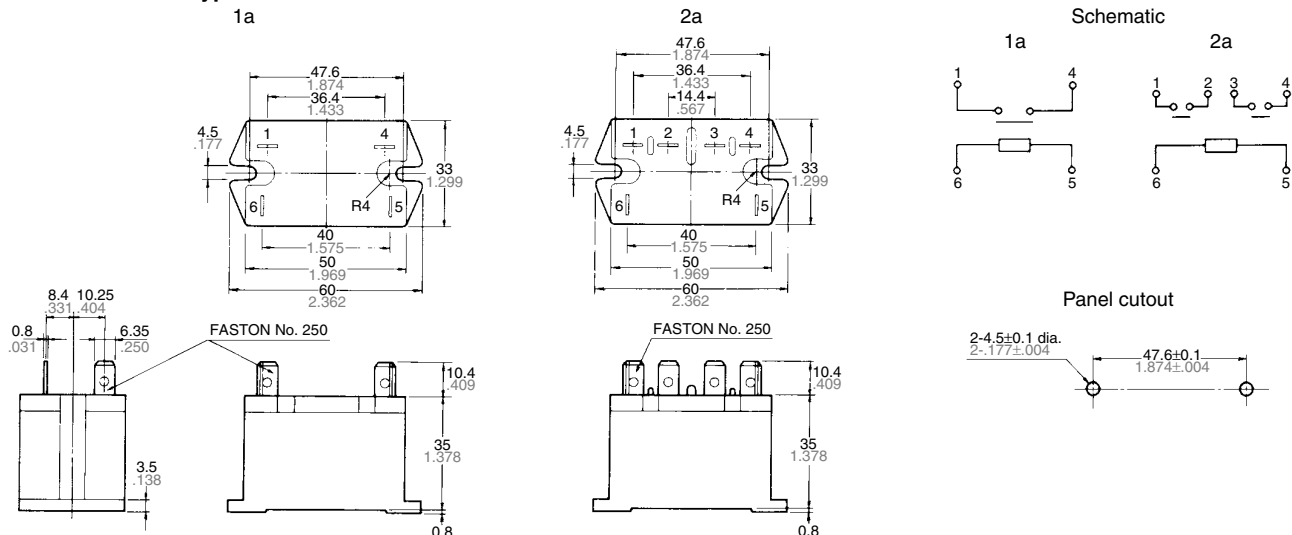

General tolerance: $\pm 0.3 \pm 0.012$

3. Screw terminal type

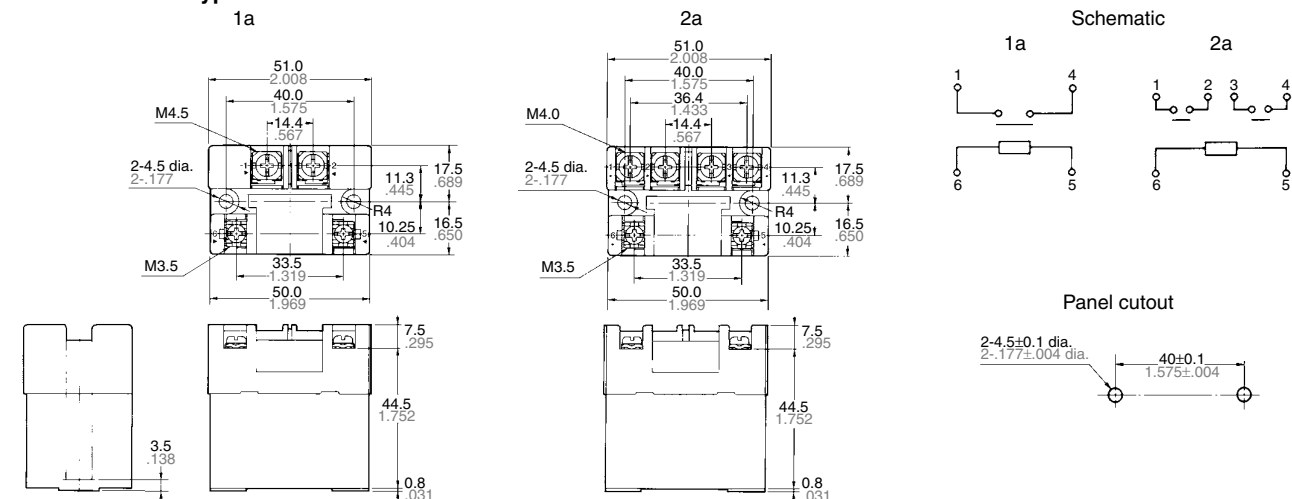

General tolerance: $\pm 0.3 \pm 0.012$

4. Screw terminal type (wide pitch)

mm inch

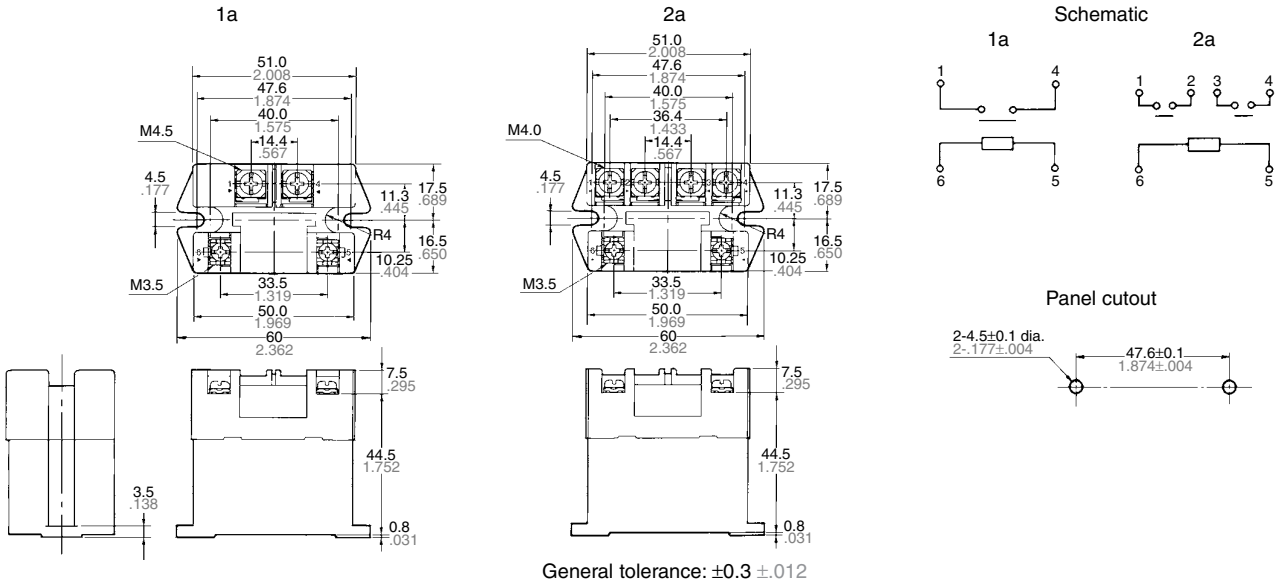

5. PC board terminal type

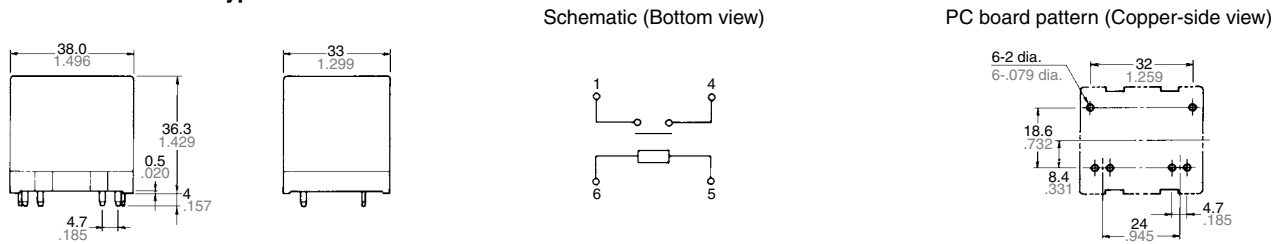

REFERENCE DATA

1 Form A Type

1. Maximum switching power

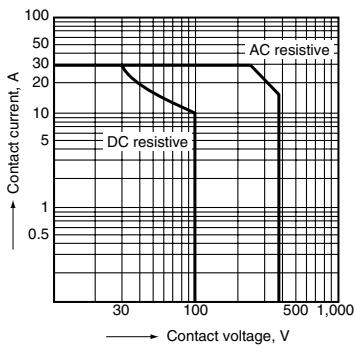

2. Life curve

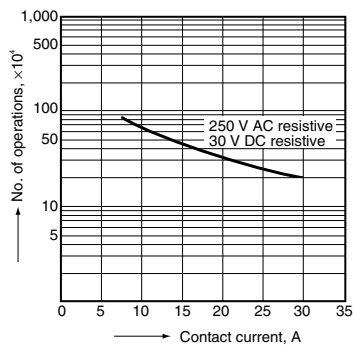

3. Contact temperature rise (DC type)

Measured portion: Inside the coil
Contact current: 30 A

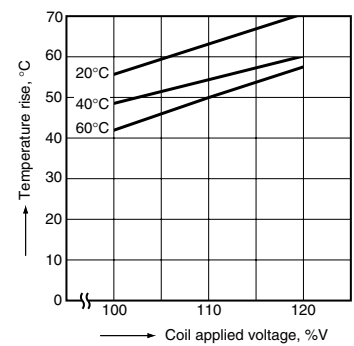

4. Ambient temperature characteristics

Sample: HE1aN-AC120V, 6 pcs.

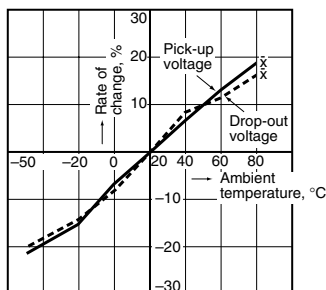

1 Form A Type

1. Maximum switching power

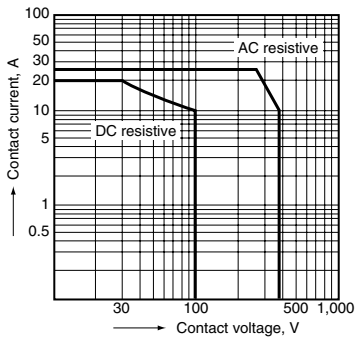

2. Life curve

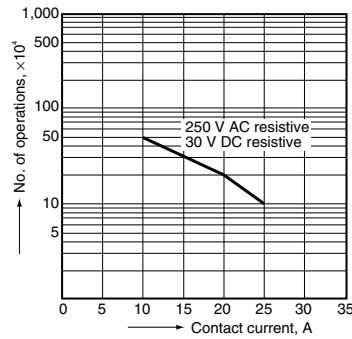

3. Contact temperature rise (DC type)

Measured portion: Inside the coil
Contact current: 30 A

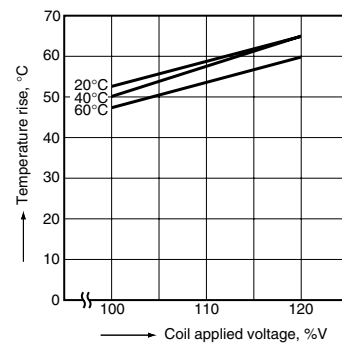

4. Ambient temperature characteristics

Sample: HE2aN-AC120V, 6 pcs.

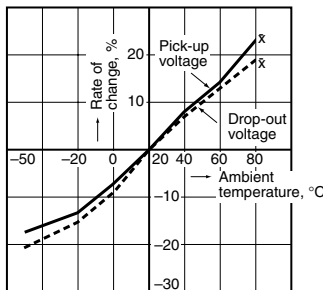

MOUNTING METHOD

1. Plug-in terminal type

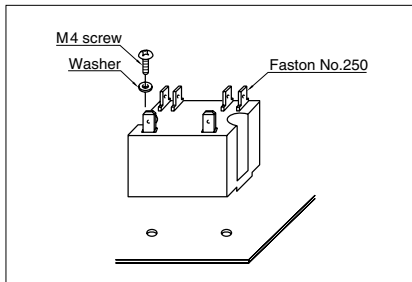

2. Screw terminal type

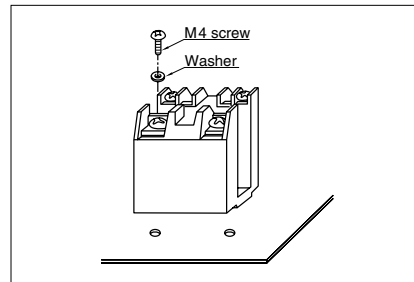

3. Allowable installation wiring size for screw terminal types and terminal blocks

1a type	2.6 mm or 5.5 mm ²
2a type	2.0 mm or 3.5 mm ²

Due to the UP terminals, it is possible to either directly connect the wires or use crimped terminal

NOTES

- The dust cover should not be removed since doing so may alter the characteristics.
- Avoid use under severe environmental conditions, such as high humidity, organic gas or in dust, oily locations and locations subjected to extremely frequent shock or vibrations.
- When mounting, use spring washers. Optimum fastening torque ranges from 5 kg to 7 kg·cm 4.5 to 6 pounds·inch.
- Firmly insert the receptacles so that there is no slack or looseness. To remove a receptacle, 2 to 4 kg of pulling strength

- is required. Do not remove more than one receptacle at one time. Always remove one receptacle at a time and pull it straight outwards.
- Install the relay so that it lies in direction A (up-down direction). (Pick-up voltage and drop-out voltage values are those when installed in direction A.)
- When using the AC type, the operate time due to the in-rush phase is 20 ms or more. Therefore, it is necessary for you to verify the characteristics for your actual circuit. Moreover, the release time for the NC side of the 2a1b type requires the

same verification.

- When using the push-on blocks for the screw terminal type, use crimped terminals and tighten the screw-down terminals to the torque's listed below.

M4.5 screw	147 N-cm to 166.6 N-cm (15 to 17 kg·cm)
M4 screw	117.6 N-cm to 137 N-cm (12 to 14 kg·cm)
M3.5 screw	78.4 N-cm to 98 N-cm (8 to 10 kg·cm)

- All AC240V types are rated for double coil voltage, both AC 220V AC 240V.

For Cautions for Use, see Relay Technical Information .

HE RELAY ACCESSORIES

Terminal socket instantly attachable to DIN rail



TYPES

Part No.	Applicable relays
JH1-SF	HE1a
JH2-SF	HE2a

SPECIFICATIONS

Part No.	JH1, JH2
Maximum continuous current*	20 A 250 V AC (1a: 30 A 250 V AC)
Breakdown voltage	2,000 Vrms between terminals
Insulation resistance	More than 1,000 MΩ between poles
Heat resistance	150°C ±3°C for 1 hour

* Don't insert or remove relays while in the energized condition.

DIMENSIONS

mm inch

1 Form A, 2 Form A

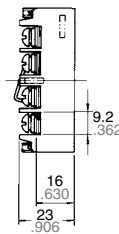
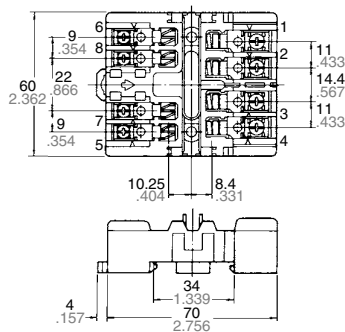

Relay mounting diagram

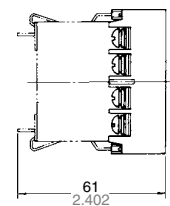

Panel cutout

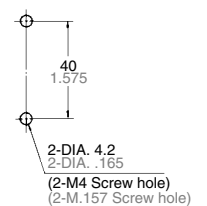

Note:

JH1-SF does not have receptacles (tooth rests) for numbers 2, 3, 7, and 8.
JH2-SF does not have receptacles (tooth rests) for numbers 7 and 8.

MOUNTING METHOD

1. Relay mounting

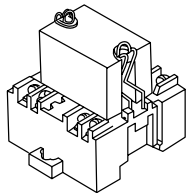

2. Installing to a DIN rail

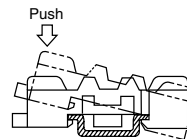

3. Removing from a DIN rail

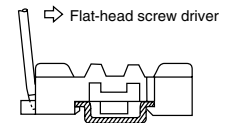

NOTE

1. Be careful not to drop the relay. It is made of heat-hardened resin and may break.

2. Be sure to tighten the screw-down terminals firmly. Loose terminals may lead to the generation of heat.