

LOW DROP FIXED AND ADJUSTABLE POSITIVE VOLTAGE REGULATORS

- LOW DROPOUT VOLTAGE
(1.15V TYP. @ $I_{OUT} = 1A$, 25°C)
- VERY LOW QUIESCENT CURRENT
(5 mA TYP. @ 25°C)
- OUTPUT CURRENT UP TO 1A
- FIXED OUTPUT VOLTAGE OF: 1.2V, 1.8V, 2.5V, 2.85V, 3.3V, 5.0V
- ADJUSTABLE VERSION AVAILABILITY
($V_{ref} = 1.25V$)
- INTERNAL CURRENT AND THERMAL LIMIT
- ONLY 10 μF FOR STABILITY
- AVAILABLE IN $\pm 2\%$ (AT 25°C) AND 4% IN FULL TEMPERATURE RANGE
- HIGH SUPPLY VOLTAGE REJECTION:
(80dB TYP. AT 25°C)
- TEMPERATURE RANGE: 0°C TO 125°C

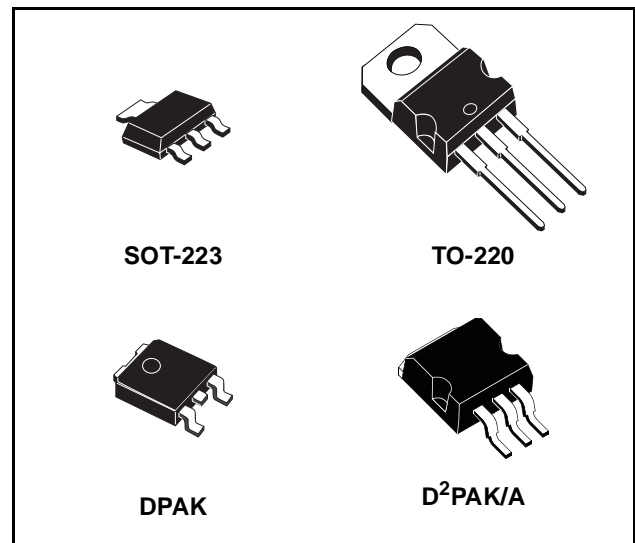

DESCRIPTION

The LD1117A is a LOW DROP Voltage Regulator able to provide up to 1A of Output Current, available even in adjustable version ($V_{ref}=1.25V$). Concerning fixed versions, are offered the following Output Voltages: 1.2V, 1.8V, 2.5V, 2.85V, 3.3V and 5.0V. The 2.85V type is ideal for SCSI-2 lines active termination. The device is

supplied in: SOT-223, DPAK, D²PAK/A and TO-220. Surface mount packages optimize the thermal characteristics even offering a relevant space saving effect. High efficiency is assured by NPN pass transistor. Only a very common 10 μF minimum capacitor is needed for stability. Only chip trimming allows the regulator to reach a very tight output voltage tolerance, within $\pm 2\%$ at 25°C.

Figure 1: Block Diagram

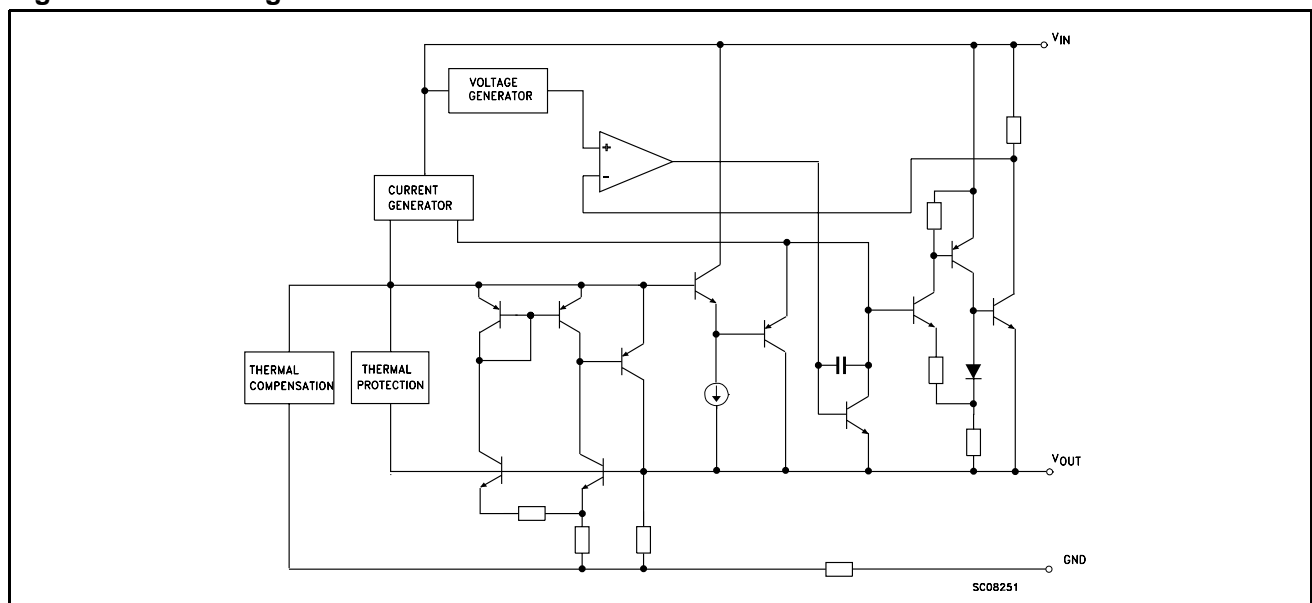

LD1117A SERIES

Table 1: Absolute Maximum Ratings

Symbol	Parameter	Value	Unit
V_{IN}	DC Input Voltage	10	V
P_{tot}	Power Dissipation	12	W
T_{stg}	Storage Temperature Range	-40 to +150	°C
T_{op}	Operating Junction Temperature Range	0 to +125	°C

Absolute Maximum Ratings are those values beyond which damage to the device may occur. Functional operation under these condition is not implied. Over the above suggested Max Power Dissipation a Short Circuit could definitively damage the device.

Table 2: Thermal Data

Symbol	Parameter	TO-220	SOT-223	DPAK	D ² PAK/A	Unit
$R_{thj-case}$	Thermal Resistance Junction-case	3	15	8	3	°C/W
$R_{thj-amb}$	Thermal Resistance Junction-ambient	50				°C/W

Figure 2: Pin Connection (top view)

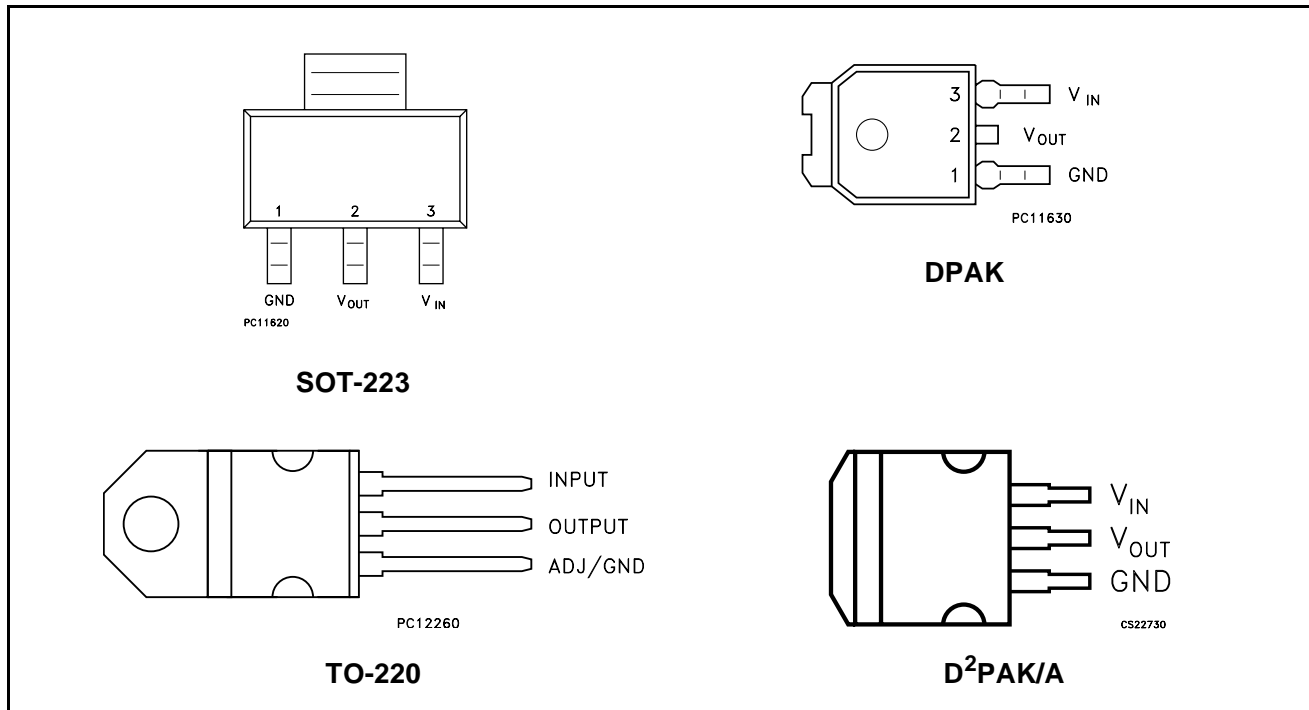

NOTE: The TAB is connected to the V_{OUT}.

Table 3: Order Codes

SOT-223	DPAK	D ² PAK/A	TO-220	OUTPUT VOLTAGE
LD1117AS12TR	LD1117ADT12TR (*)		LD1117AV12 (*)	1.2 V
LD1117AS18TR	LD1117ADT18TR		LD1117AV18	1.8 V
LD1117AS25TR	LD1117ADT25TR		LD1117AV25	2.5 V
LD1117AS28TR (*)	LD1117ADT28TR (*)		LD1117AV28 (*)	2.85 V
LD1117AS33TR	LD1117ADT33TR		LD1117AV33	3.3 V
LD1117AS50TR (*)	LD1117ADT50TR (*)		LD1117AV50 (*)	5 V
LD1117ASTR	LD1117ADT-TR	LD1117AD2MTR	LD1117AV	ADJUSTABLE FROM 1.25 TO 15 V

(*) On request



Figure 3: Application Circuit (For Other Fixed Output Voltages)

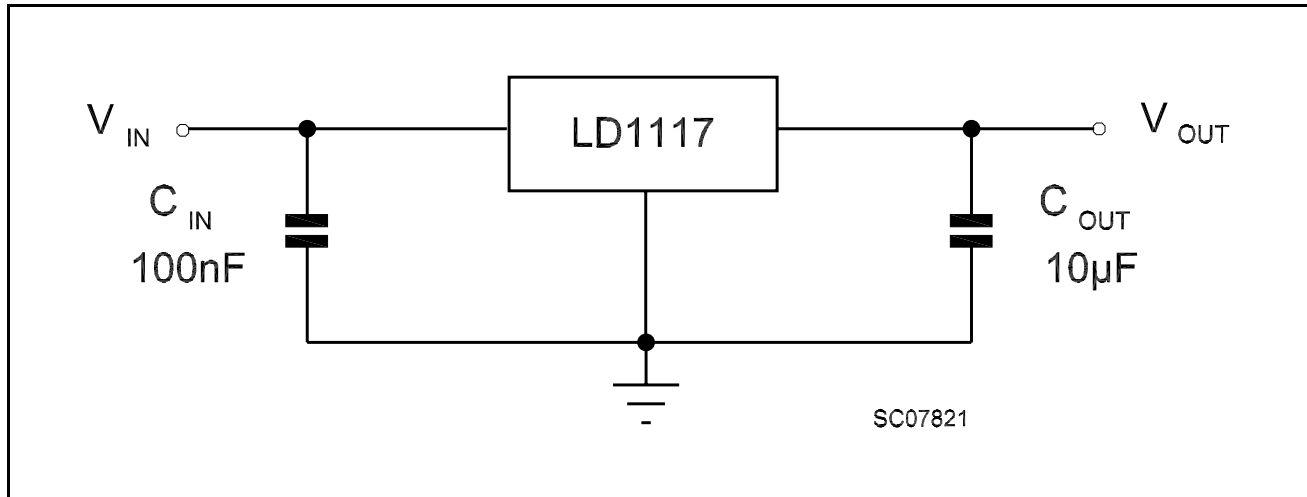

Table 4: Electrical Characteristics Of LD1117A#12 (refer to the test circuits, $T_J = 0$ to 125°C , $C_O = 10$ μF , $C_I = 10$ μF , $R = 120$ Ω between OUT-GND, unless otherwise specified)

Symbol	Parameter	Test Conditions	Min.	Typ.	Max.	Unit
V_O	Output Voltage	$V_I = 5.3$ V $I_O = 10$ mA $T_J = 25^\circ\text{C}$	1.176	1.2	1.224	V
V_O	Output Voltage	$I_O = 0$ to 1 A $V_I = 2.75$ to 10 V	1.152	1.2	1.248	V
ΔV_O	Line Regulation	$V_I = 2.75$ to 8 V $I_O = 0$ mA		1	6	mV
ΔV_O	Load Regulation	$V_I = 2.75$ V $I_O = 0$ to 1 A		1	10	mV
ΔV_O	Temperature Stability			0.5		%
ΔV_O	Long Term Stability	1000 hrs, $T_J = 125^\circ\text{C}$		0.3		%
V_I	Operating Input Voltage	$I_O = 100$ mA			10	V
I_d	Quiescent Current	$V_I \leq 8$ V $I_O = 0$ mA		5	10	mA
I_O	Output Current	$V_I - V_O = 5$ V $T_J = 25^\circ\text{C}$	1000	1200		mA
eN	Output Noise Voltage	B = 10Hz to 10KHz $T_J = 25^\circ\text{C}$		100		μV
SVR	Supply Voltage Rejection	$I_O = 40$ mA $f = 120$ Hz $V_I - V_O = 3$ V $V_{\text{ripple}} = 1$ V _{PP}	60	80		dB
V_D	Dropout Voltage	$I_O = 100$ mA		1	1.10	V
		$I_O = 500$ mA		1.05	1.15	
		$I_O = 1$ A		1.15	1.30	
$\Delta V_{O(\text{pwr})}$	Thermal Regulation	$T_a = 25^\circ\text{C}$ 30ms Pulse		0.08	0.2	%/W

LD1117A SERIES

Table 5: Electrical Characteristics Of LD1117A#18 (refer to the test circuits, $T_J = 0$ to 125°C , $C_O = 10 \mu\text{F}$, $C_I = 10 \mu\text{F}$ unless otherwise specified)

Symbol	Parameter	Test Conditions	Min.	Typ.	Max.	Unit
V_O	Output Voltage	$V_I = 3.8 \text{ V}$ $I_O = 10 \text{ mA}$ $T_J = 25^\circ\text{C}$	1.764	1.8	1.836	V
V_O	Output Voltage	$I_O = 0$ to 1 A $V_I = 3.3$ to 8 V	1.728		1.872	V
ΔV_O	Line Regulation	$V_I = 3.3$ to 8 V $I_O = 0 \text{ mA}$		1	6	mV
ΔV_O	Load Regulation	$V_I = 3.3 \text{ V}$ $I_O = 0$ to 1 A		1	10	mV
ΔV_O	Temperature Stability			0.5		%
ΔV_O	Long Term Stability	1000 hrs, $T_J = 125^\circ\text{C}$		0.3		%
V_I	Operating Input Voltage	$I_O = 100 \text{ mA}$			10	V
I_d	Quiescent Current	$V_I \leq 8 \text{ V}$ $I_O = 0 \text{ mA}$		5	10	mA
I_O	Output Current	$V_I - V_O = 5 \text{ V}$ $T_J = 25^\circ\text{C}$	1000			mA
eN	Output Noise Voltage	$B = 10\text{Hz}$ to 10KHz $T_J = 25^\circ\text{C}$		100		μV
SVR	Supply Voltage Rejection	$I_O = 40 \text{ mA}$ $f = 120\text{Hz}$ $V_I - V_O = 3 \text{ V}$ $V_{\text{ripple}} = 1 \text{ V}_{\text{PP}}$	60	80		dB
V_D	Dropout Voltage	$I_O = 100 \text{ mA}$		1	1.10	V
		$I_O = 500 \text{ mA}$		1.05	1.15	
		$I_O = 1 \text{ A}$		1.15	1.30	
$\Delta V_{O(\text{pwr})}$	Thermal Regulation	$T_a = 25^\circ\text{C}$ 30ms Pulse		0.08	0.2	%/W

Table 6: Electrical Characteristics Of LD1117A#25 (refer to the test circuits, $T_J = 0$ to 125°C , $C_O = 10 \mu\text{F}$, $C_I = 10 \mu\text{F}$ unless otherwise specified)

Symbol	Parameter	Test Conditions	Min.	Typ.	Max.	Unit
V_O	Output Voltage	$V_I = 4.5 \text{ V}$ $I_O = 10 \text{ mA}$ $T_J = 25^\circ\text{C}$	2.45	2.5	2.55	V
V_O	Output Voltage	$I_O = 0$ to 1 A $V_I = 3.9$ to 8 V	2.4		2.6	V
ΔV_O	Line Regulation	$V_I = 3.9$ to 8 V $I_O = 0 \text{ mA}$		1	6	mV
ΔV_O	Load Regulation	$V_I = 3.9 \text{ V}$ $I_O = 0$ to 1 A		1	10	mV
ΔV_O	Temperature Stability			0.5		%
ΔV_O	Long Term Stability	1000 hrs, $T_J = 125^\circ\text{C}$		0.3		%
V_I	Operating Input Voltage	$I_O = 100 \text{ mA}$			10	V
I_d	Quiescent Current	$V_I \leq 10 \text{ V}$ $I_O = 0 \text{ mA}$		5	10	mA
I_O	Output Current	$V_I - V_O = 5 \text{ V}$ $T_J = 25^\circ\text{C}$	1000	1200		mA
eN	Output Noise Voltage	$B = 10\text{Hz}$ to 10KHz $T_J = 25^\circ\text{C}$		100		μV
SVR	Supply Voltage Rejection	$I_O = 40 \text{ mA}$ $f = 120\text{Hz}$ $V_I - V_O = 3 \text{ V}$ $V_{\text{ripple}} = 1 \text{ V}_{\text{PP}}$	60	80		dB
V_D	Dropout Voltage	$I_O = 100 \text{ mA}$		1	1.10	V
		$I_O = 500 \text{ mA}$		1.05	1.15	
		$I_O = 1 \text{ A}$		1.15	1.30	
$\Delta V_{O(\text{pwr})}$	Thermal Regulation	$T_a = 25^\circ\text{C}$ 30ms Pulse		0.08	0.2	%/W

Table 7: Electrical Characteristics Of LD1117A#28 (refer to the test circuits, $T_J = 0$ to 125°C , $C_O = 10 \mu\text{F}$, $C_I = 10 \mu\text{F}$ unless otherwise specified)

Symbol	Parameter	Test Conditions	Min.	Typ.	Max.	Unit
V_O	Output Voltage	$V_I = 4.85 \text{ V}$ $I_O = 10 \text{ mA}$ $T_J = 25^\circ\text{C}$	2.793	2.85	2.907	V
V_O	Output Voltage	$I_O = 0$ to 1 A $V_I = 4.25$ to 10 V	2.736		2.964	V
ΔV_O	Line Regulation	$V_I = 4.25$ to 8 V $I_O = 0 \text{ mA}$		1	6	mV
ΔV_O	Load Regulation	$V_I = 4.25 \text{ V}$ $I_O = 0$ to 1 A		1	10	mV
ΔV_O	Temperature Stability			0.5		%
ΔV_O	Long Term Stability	1000 hrs, $T_J = 125^\circ\text{C}$		0.3		%
V_I	Operating Input Voltage	$I_O = 100 \text{ mA}$			10	V
I_d	Quiescent Current	$V_I \leq 10 \text{ V}$ $I_O = 0 \text{ mA}$		4.5	10	mA
I_O	Output Current	$V_I - V_O = 5 \text{ V}$ $T_J = 25^\circ\text{C}$	1000	1200		mA
eN	Output Noise Voltage	$B = 10\text{Hz}$ to 10KHz $T_J = 25^\circ\text{C}$		100		μV
SVR	Supply Voltage Rejection	$I_O = 40 \text{ mA}$ $f = 120\text{Hz}$ $V_I - V_O = 3 \text{ V}$ $V_{\text{ripple}} = 1 \text{ V}_{\text{PP}}$	60	75		dB
V_D	Dropout Voltage	$I_O = 100 \text{ mA}$		1	1.10	V
		$I_O = 500 \text{ mA}$		1.05	1.15	
		$I_O = 1 \text{ A}$		1.15	1.30	
$\Delta V_{O(\text{pwr})}$	Thermal Regulation	$T_a = 25^\circ\text{C}$ 30ms Pulse		0.08	0.2	%/W

Table 8: Electrical Characteristics Of LD1117A#33 (refer to the test circuits, $T_J = 0$ to 125°C , $C_O = 10 \mu\text{F}$, $C_I = 10 \mu\text{F}$ unless otherwise specified)

Symbol	Parameter	Test Conditions	Min.	Typ.	Max.	Unit
V_O	Output Voltage	$V_I = 5.3 \text{ V}$ $I_O = 10 \text{ mA}$ $T_J = 25^\circ\text{C}$	3.234	3.3	3.366	V
V_O	Output Voltage	$I_O = 0$ to 1 A $V_I = 4.75$ to 10 V	3.168		3.432	V
ΔV_O	Line Regulation	$V_I = 4.75$ to 8 V $I_O = 0 \text{ mA}$		1	6	mV
ΔV_O	Load Regulation	$V_I = 4.75 \text{ V}$ $I_O = 0$ to 1 A		1	10	mV
ΔV_O	Temperature Stability			0.5		%
ΔV_O	Long Term Stability	1000 hrs, $T_J = 125^\circ\text{C}$		0.3		%
V_I	Operating Input Voltage	$I_O = 100 \text{ mA}$			10	V
I_d	Quiescent Current	$V_I \leq 10 \text{ V}$ $I_O = 0 \text{ mA}$		5	10	mA
I_O	Output Current	$V_I - V_O = 5 \text{ V}$ $T_J = 25^\circ\text{C}$	1000	1200		mA
eN	Output Noise Voltage	$B = 10\text{Hz}$ to 10KHz $T_J = 25^\circ\text{C}$		100		μV
SVR	Supply Voltage Rejection	$I_O = 40 \text{ mA}$ $f = 120\text{Hz}$ $V_I - V_O = 3 \text{ V}$ $V_{\text{ripple}} = 1 \text{ V}_{\text{PP}}$	60	75		dB
V_D	Dropout Voltage	$I_O = 100 \text{ mA}$		1	1.10	V
		$I_O = 500 \text{ mA}$		1.05	1.15	
		$I_O = 1 \text{ A}$		1.15	1.30	
$\Delta V_{O(\text{pwr})}$	Thermal Regulation	$T_a = 25^\circ\text{C}$ 30ms Pulse		0.08	0.2	%/W

LD1117A SERIES

Table 9: Electrical Characteristics Of LD1117A#50 (refer to the test circuits, $T_J = 0$ to 125°C , $C_O = 10 \mu\text{F}$, $C_I = 10 \mu\text{F}$ unless otherwise specified)

Symbol	Parameter	Test Conditions	Min.	Typ.	Max.	Unit
V_O	Output Voltage	$V_I = 7 \text{ V}$ $I_O = 10 \text{ mA}$ $T_J = 25^\circ\text{C}$	4.9	5	5.1	V
V_O	Output Voltage	$I_O = 0$ to 1 A $V_I = 6.4$ to 10 V	4.8		5.2	V
ΔV_O	Line Regulation	$V_I = 6.4$ to 8 V $I_O = 0 \text{ mA}$		1	6	mV
ΔV_O	Load Regulation	$V_I = 6.4 \text{ V}$ $I_O = 0$ to 1 A		1	10	mV
ΔV_O	Temperature Stability			0.5		%
ΔV_O	Long Term Stability	1000 hrs, $T_J = 125^\circ\text{C}$		0.3		%
V_I	Operating Input Voltage	$I_O = 100 \text{ mA}$			10	V
I_d	Quiescent Current	$V_I \leq 10 \text{ V}$ $I_O = 0 \text{ mA}$		5	10	mA
I_O	Output Current	$V_I - V_O = 5 \text{ V}$ $T_J = 25^\circ\text{C}$	1000	1200		mA
eN	Output Noise Voltage	$B = 10\text{Hz}$ to 10KHz $T_J = 25^\circ\text{C}$		100		μV
SVR	Supply Voltage Rejection	$I_O = 40 \text{ mA}$ $f = 120\text{Hz}$ $V_I - V_O = 3 \text{ V}$ $V_{\text{ripple}} = 1 \text{ V}_{\text{PP}}$	60	80		dB
V_D	Dropout Voltage	$I_O = 100 \text{ mA}$		1	1.10	V
		$I_O = 500 \text{ mA}$		1.05	1.15	
		$I_O = 1 \text{ A}$		1.15	1.30	
$\Delta V_{O(\text{pwr})}$	Thermal Regulation	$T_a = 25^\circ\text{C}$ 30ms Pulse		0.08	0.2	%/W

Table 10: Electrical Characteristics Of LD1117A (Adjustable) (refer to the test circuits, $T_J = 0$ to 125°C , $C_O = 10 \mu\text{F}$, $C_I = 10 \mu\text{F}$ unless otherwise specified)

Symbol	Parameter	Test Conditions	Min.	Typ.	Max.	Unit
V_O	Output Voltage	$V_I = 5.3 \text{ V}$ $I_O = 10 \text{ mA}$ $T_J = 25^\circ\text{C}$	1.225	1.25	1.275	V
V_O	Output Voltage	$I_O = 0$ to 1 A $V_I = 2.75$ to 10 V	1.2		1.3	V
ΔV_O	Line Regulation	$V_I = 2.75$ to 8 V $I_O = 0 \text{ mA}$		1	6	mV
ΔV_O	Load Regulation	$V_I = 2.75 \text{ V}$ $I_O = 0$ to 1 A		1	10	mV
ΔV_O	Temperature Stability			0.5		%
ΔV_O	Long Term Stability	1000 hrs, $T_J = 125^\circ\text{C}$		0.3		%
V_I	Operating Input Voltage	$I_O = 100 \text{ mA}$			10	V
I_d	Quiescent Current	$V_I \leq 8 \text{ V}$ $I_O = 0 \text{ mA}$		5	10	mA
I_O	Output Current	$V_I - V_O = 5 \text{ V}$ $T_J = 25^\circ\text{C}$	1000	1200		mA
eN	Output Noise Voltage	$B = 10\text{Hz}$ to 10KHz $T_J = 25^\circ\text{C}$		100		μV
SVR	Supply Voltage Rejection	$I_O = 40 \text{ mA}$ $f = 120\text{Hz}$ $V_I - V_O = 3 \text{ V}$ $V_{\text{ripple}} = 1 \text{ V}_{\text{PP}}$	60	80		dB
V_D	Dropout Voltage	$I_O = 100 \text{ mA}$		1	1.10	V
		$I_O = 500 \text{ mA}$		1.05	1.15	
		$I_O = 1 \text{ A}$		1.15	1.30	
$\Delta V_{O(\text{pwr})}$	Thermal Regulation	$T_a = 25^\circ\text{C}$ 30ms Pulse		0.08	0.2	%/W

TYPICAL APPLICATIONS

Figure 4: Negative Supply

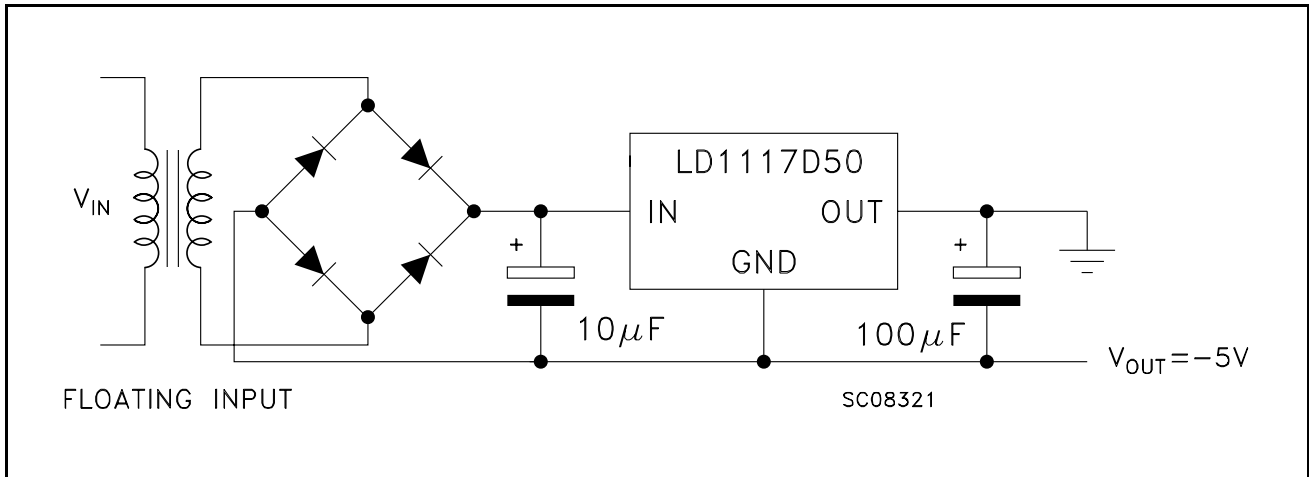

Figure 5: Active Terminator for SCSI-2 BUS

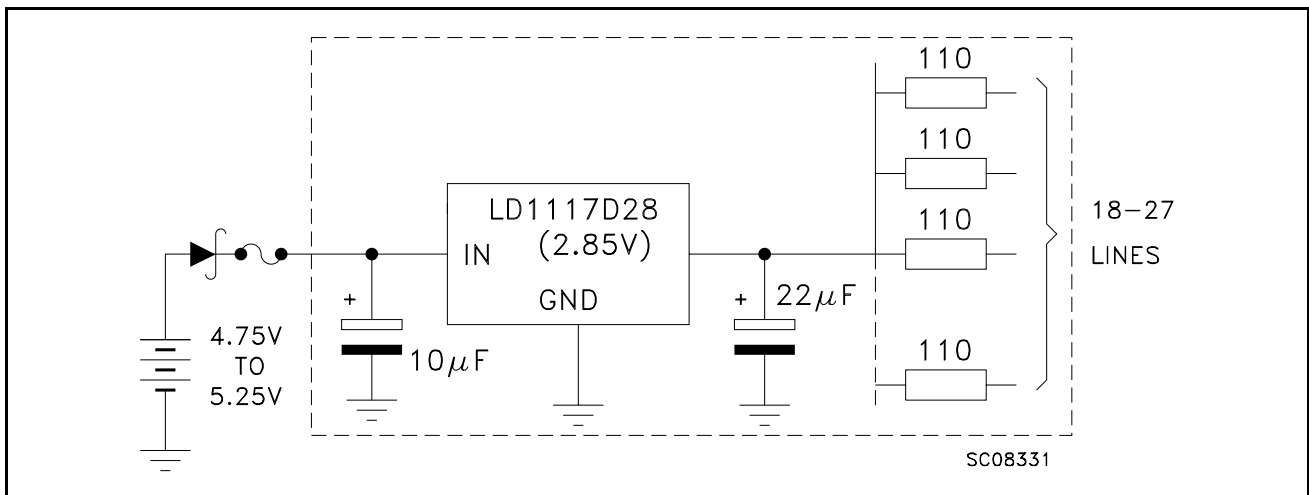

Figure 6: Circuit for Increasing Output Voltage

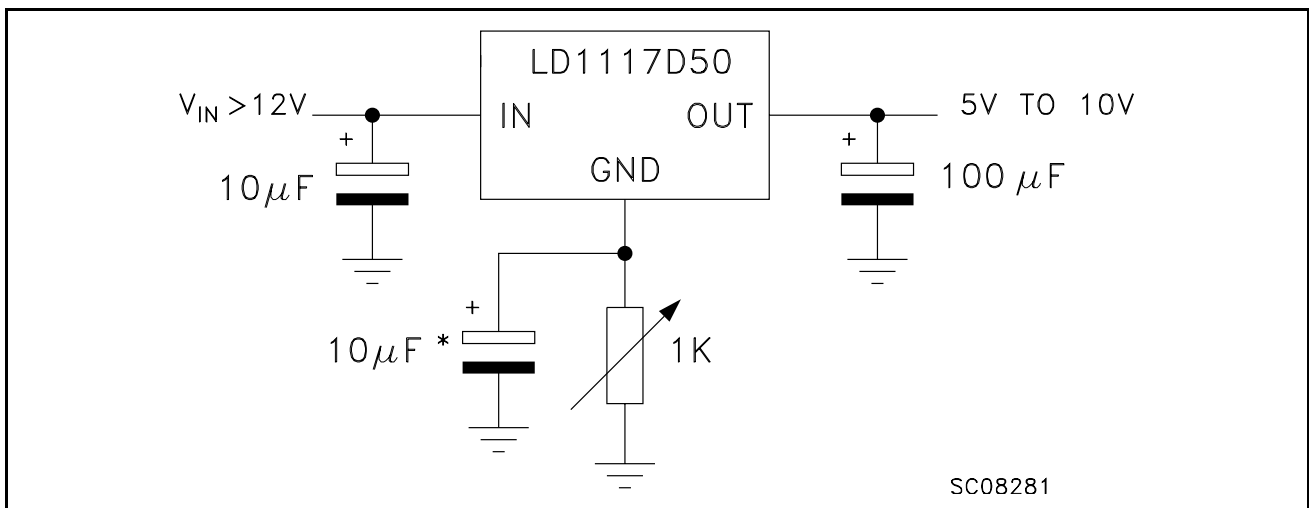

Figure 7: Voltage Regulator With Reference

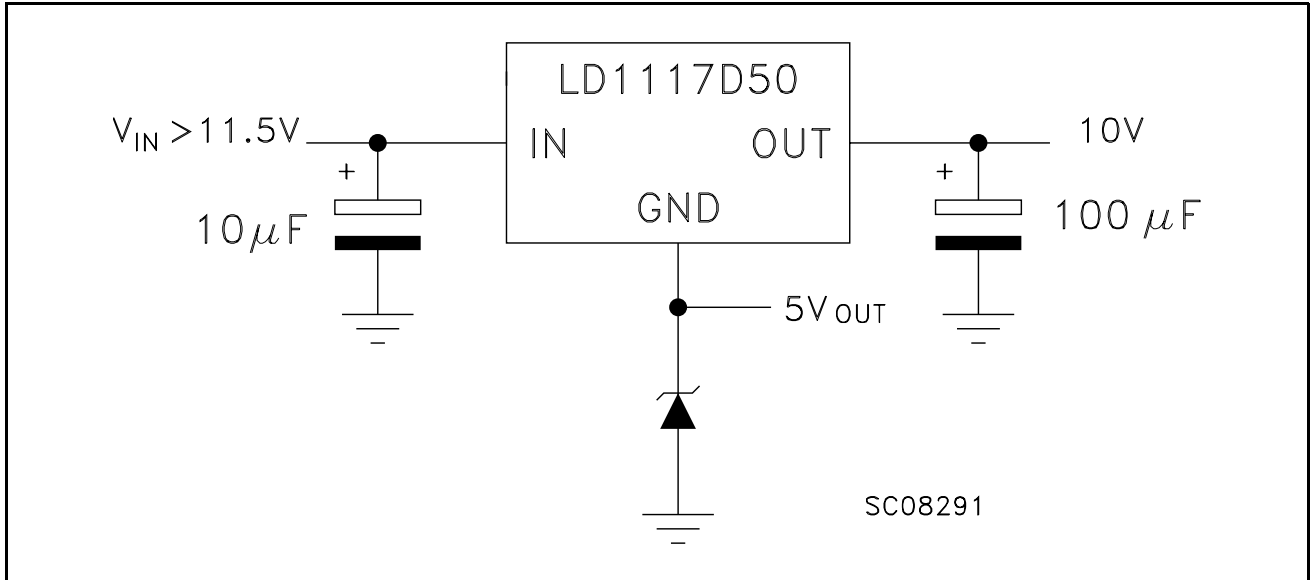

Figure 8: Battery Backed-up Regulated Supply

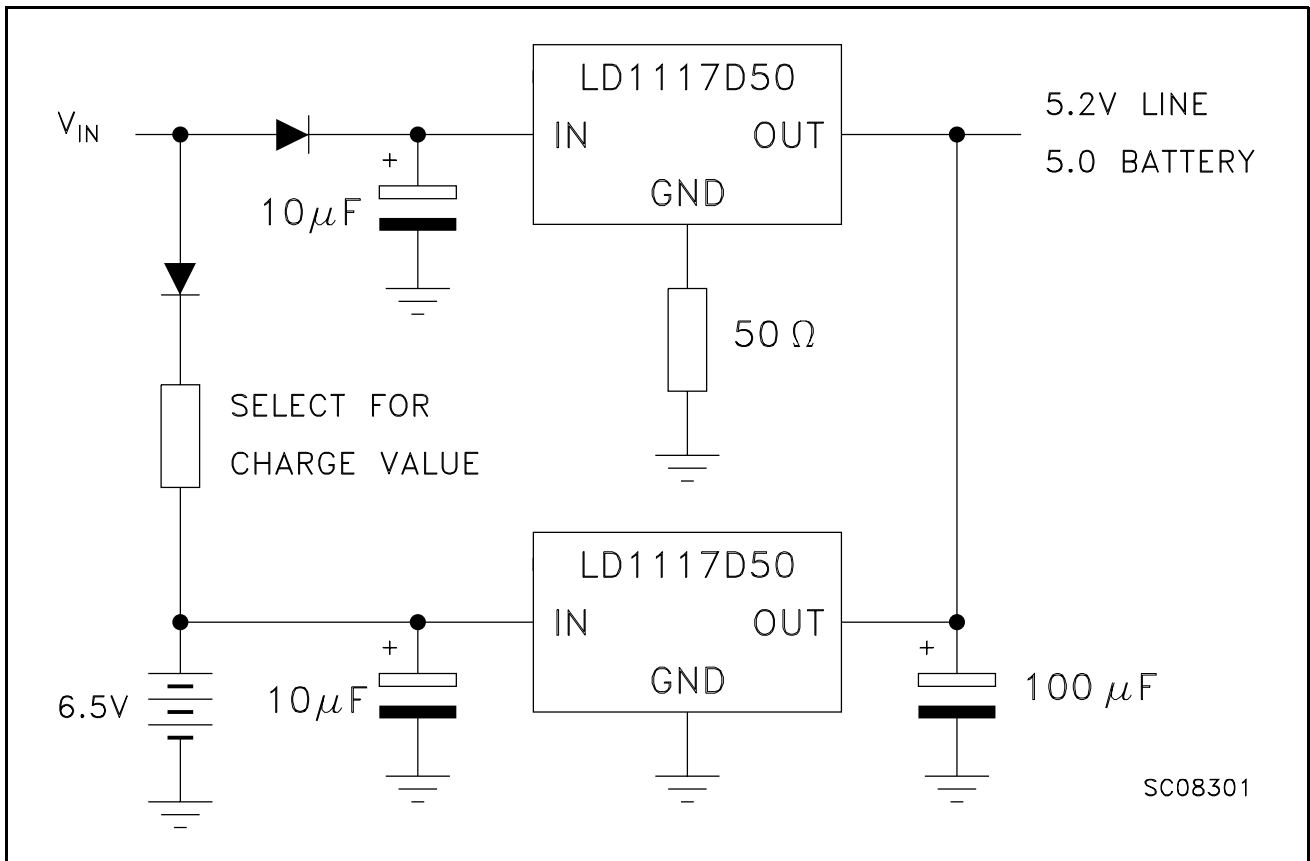
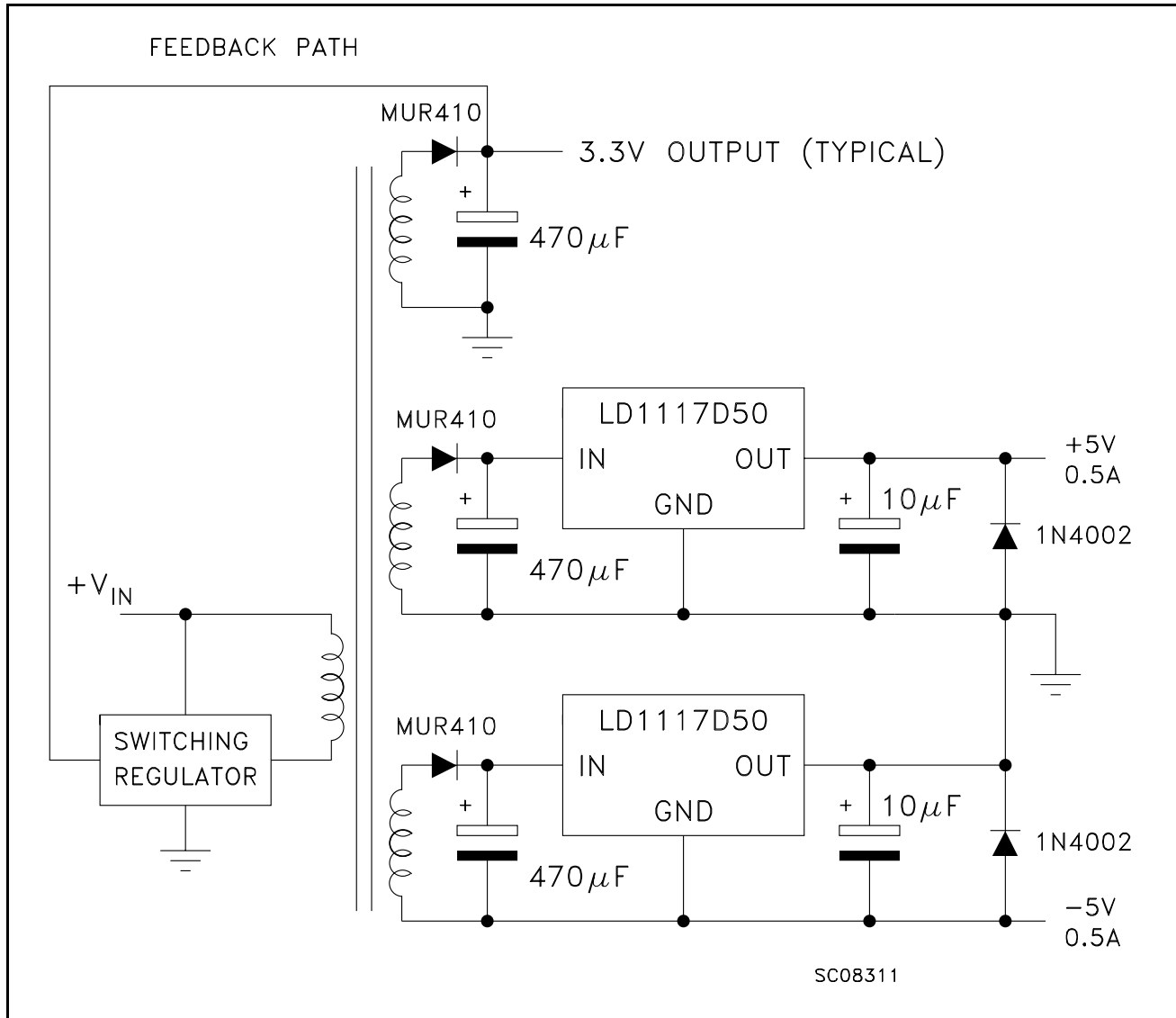

Figure 9: Post-Regulated Dual Supply

**LD1117A ADJUSTABLE: APPLICATION NOTE**

The LD1117A ADJUSTABLE has a thermal stabilized $1.25 \pm 0.012\text{V}$ reference voltage between the OUT and ADJ pins. I_{ADJ} is $60\mu\text{A}$ typ. ($120\mu\text{A}$ max.) and ΔI_{ADJ} is $1\mu\text{A}$ typ. ($5\mu\text{A}$ max.).

R_1 is normally fixed to 120Ω . From figure 7 we obtain:

$$V_{OUT} = V_{REF} + R_2 (I_{ADJ} + I_{R1}) = V_{REF} + R_2 (I_{ADJ} + V_{REF}/R_1) = V_{REF} (1 + R_2 / R_1) + R_2 \times I_{ADJ}$$

In normal application R_2 value is in the range of few Kohm, so the $R_2 \times I_{DJ}$ product could not be

considered in the V_{OUT} calculation; then the above expression becomes:

$$V_{OUT} = V_{REF} (1 + R_2 / R_1)$$

In order to have the better load regulation it is important to realize a good Kelvin connection of R_1 and R_2 resistors. In particular R_1 connection must be realized very close to OUT and ADJ pin, while R_2 ground connection must be placed as near as possible to the negative Load pin. Ripple rejection can be improved by introducing a $10\mu\text{F}$ electrolytic capacitor placed in parallel to the R_2 resistor (see Fig. 10).

Figure 10: Adjustable Output Voltage Application

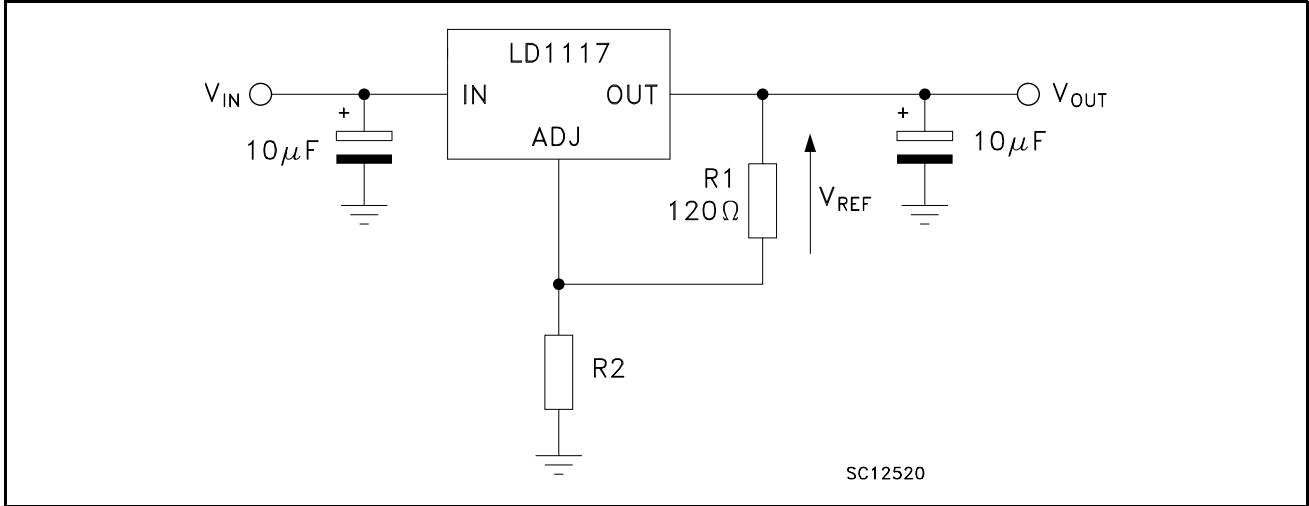
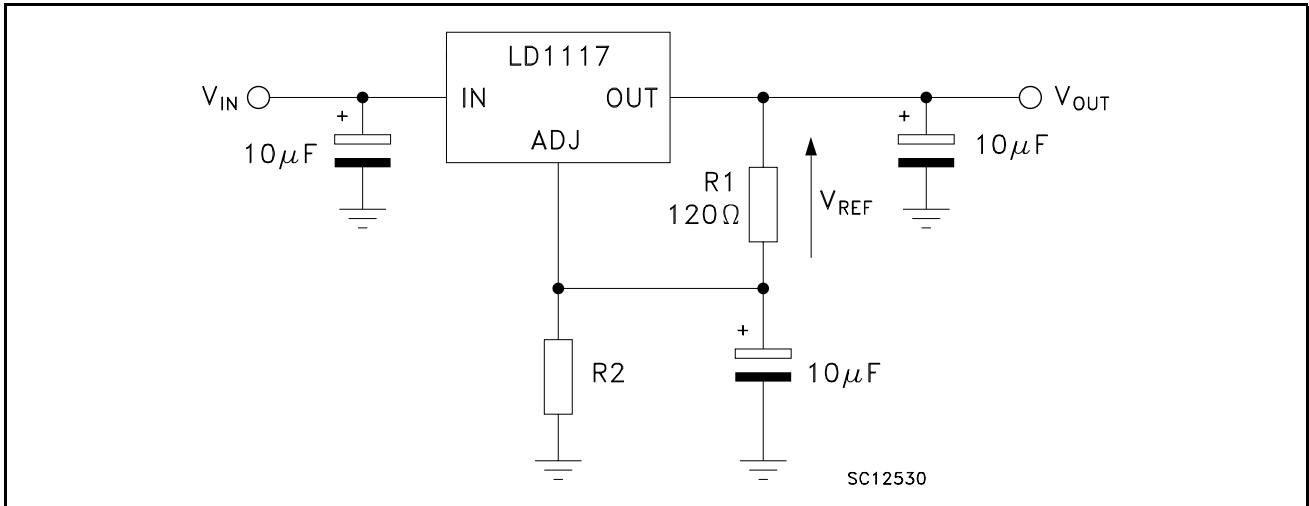
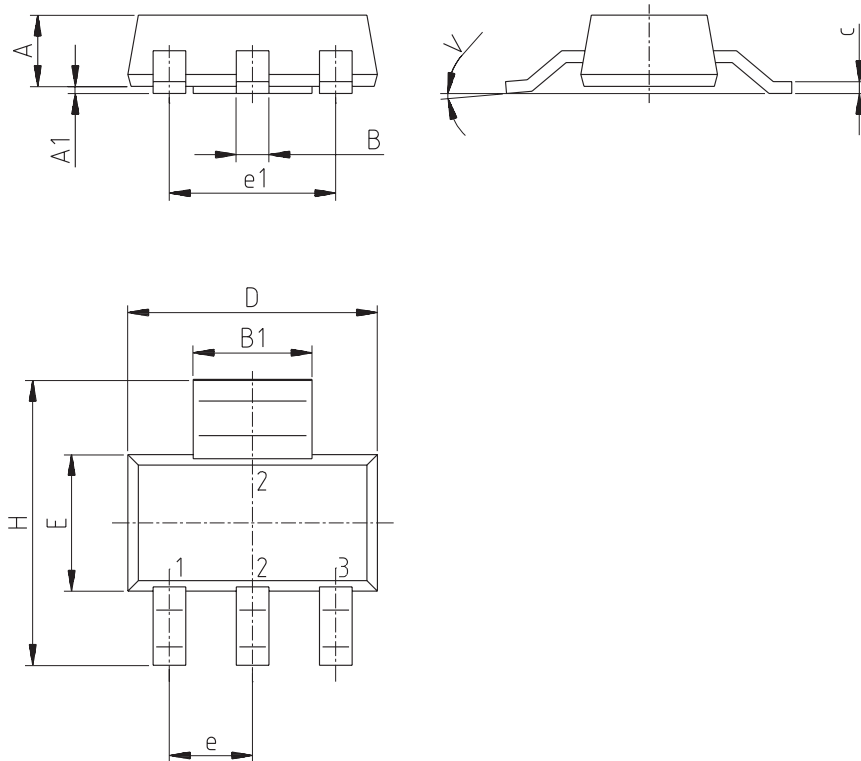

Figure 11: Adjustable Output Voltage Application with improved Ripple Rejection



SOT-223 MECHANICAL DATA

DIM.	mm.			mils		
	MIN.	TYP	MAX.	MIN.	TYP.	MAX.
A			1.8			70.9
A1	0.02		0.1	0.8		3.9
B	0.6	0.7	0.85	23.6	27.6	33.5
B1	2.9	3	3.15	114.2	118.1	124.0
c	0.24	0.26	0.35	9.4	10.2	13.8
D	6.3	6.5	6.7	248.0	255.9	263.8
e		2.3			90.6	
e1		4.6			181.1	
E	3.3	3.5	3.7	129.9	137.8	145.7
H	6.7	7	7.3	129.9	137.8	145.7
V			10°			10°



0046067/H

DPAK MECHANICAL DATA

DIM.	mm.			inch		
	MIN.	TYP	MAX.	MIN.	TYP.	MAX.
A	2.2		2.4	0.086		0.094
A1	0.9		1.1	0.035		0.043
A2	0.03		0.23	0.001		0.009
B	0.64		0.9	0.025		0.035
b4	5.2		5.4	0.204		0.212
C	0.45		0.6	0.017		0.023
C2	0.48		0.6	0.019		0.023
D	6		6.2	0.236		0.244
D1		5.1			0.200	
E	6.4		6.6	0.252		0.260
E1		4.7			0.185	
e		2.28			0.090	
e1	4.4		4.6	0.173		0.181
H	9.35		10.1	0.368		0.397
L	1			0.039		
(L1)		2.8			0.110	
L2		0.8			0.031	
L4	0.6		1	0.023		0.039

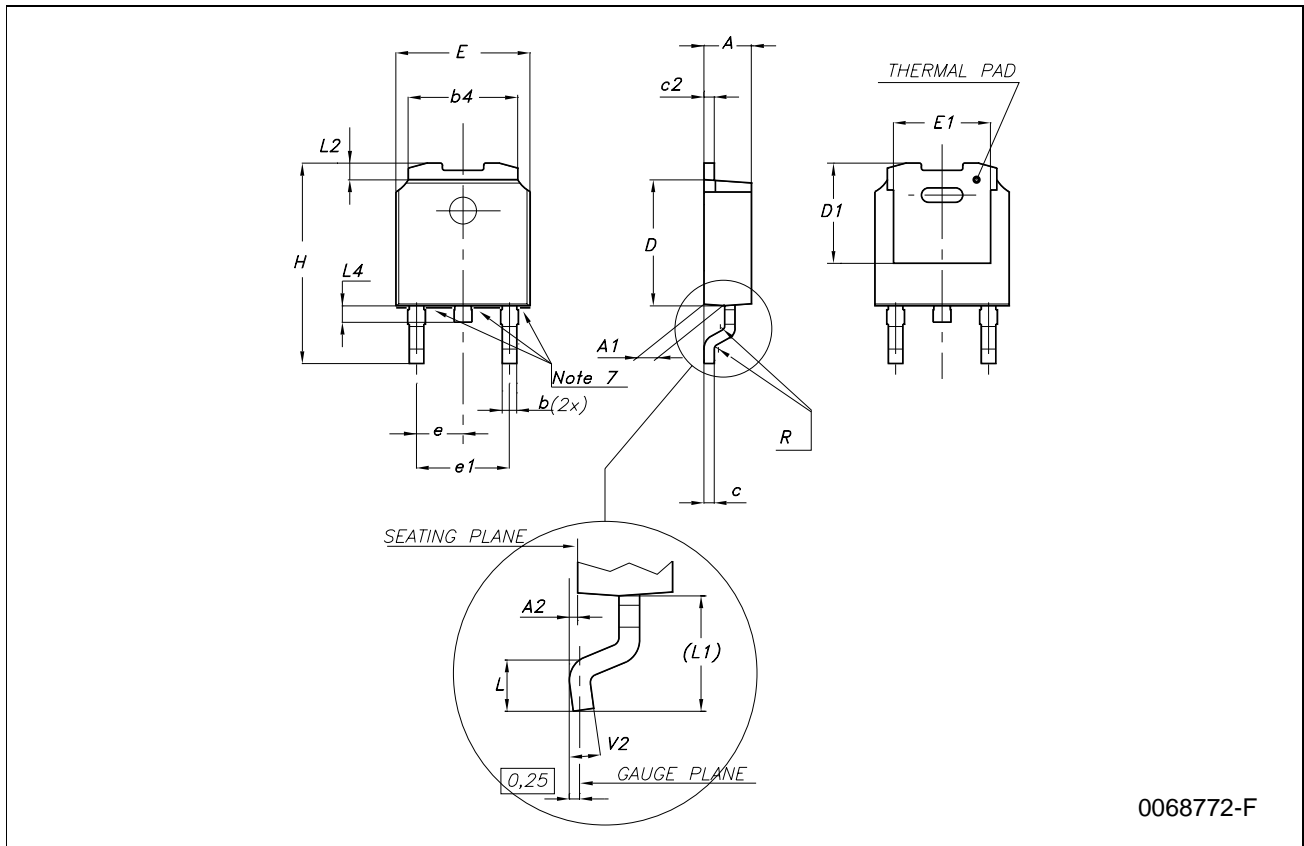

0068772-F

TO-220 MECHANICAL DATA

DIM.	mm.			inch		
	MIN.	TYP	MAX.	MIN.	TYP.	MAX.
A	4.40		4.60	0.173		0.181
C	1.23		1.32	0.048		0.051
D	2.40		2.72	0.094		0.107
D1		1.27			0.050	
E	0.49		0.70	0.019		0.027
F	0.61		0.88	0.024		0.034
F1	1.14		1.70	0.044		0.067
F2	1.14		1.70	0.044		0.067
G	4.95		5.15	0.194		0.203
G1	2.4		2.7	0.094		0.106
H2	10.0		10.40	0.393		0.409
L2		16.4			0.645	
L4	13.0		14.0	0.511		0.551
L5	2.65		2.95	0.104		0.116
L6	15.25		15.75	0.600		0.620
L7	6.2		6.6	0.244		0.260
L9	3.5		3.93	0.137		0.154
DIA.	3.75		3.85	0.147		0.151

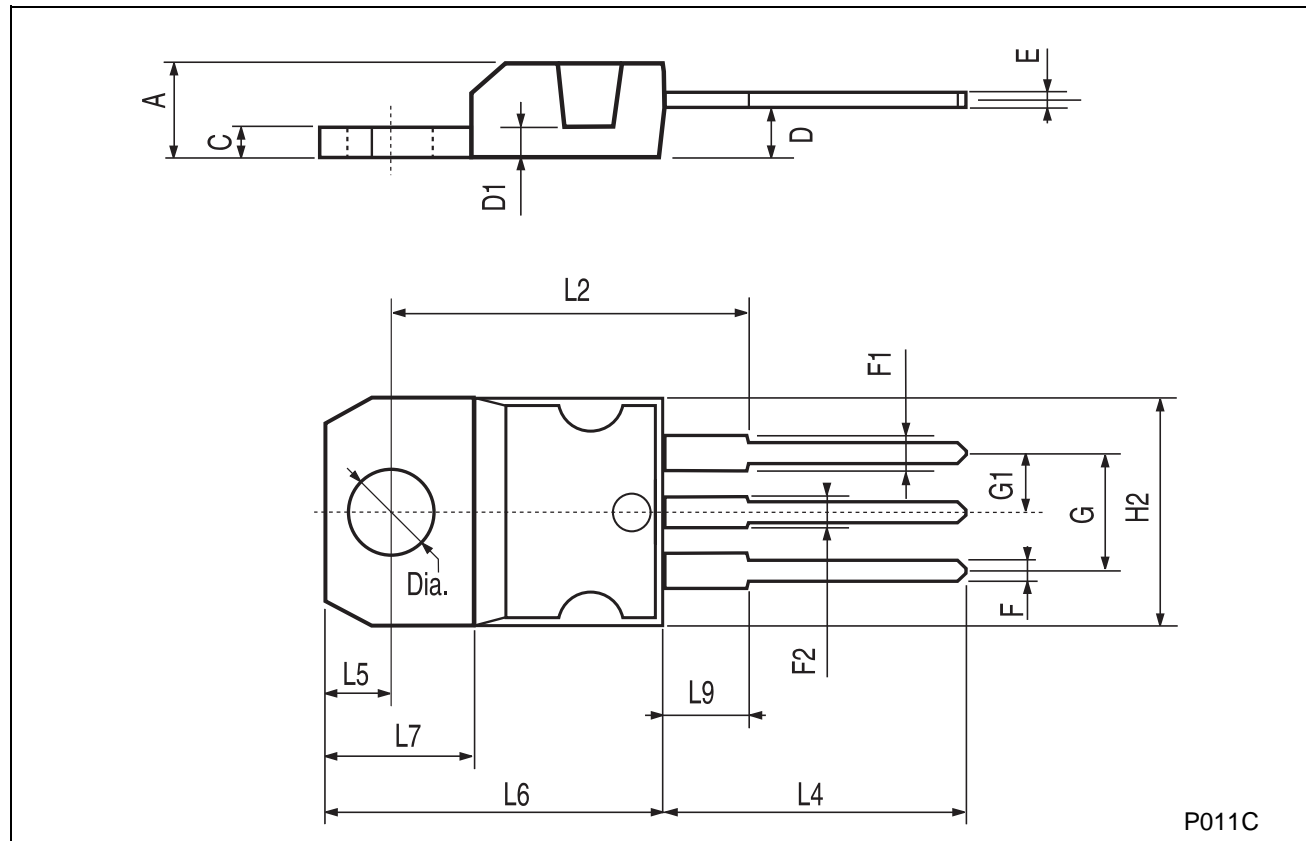

D²PAK/A MECHANICAL DATA

DIM.	mm.			inch		
	MIN.	TYP	MAX.	MIN.	TYP.	MAX.
A	4.40		4.60	0.173		0.181
A1	2.49		2.69	0.098		0.106
A2	0.03		0.23	0.001		0.009
B	0.7		0.93	0.028		0.037
B1	0.8		1.3	0.031		0.051
B2	1.14		1.7	0.045		0.067
C	0.45		0.60	0.018		0.024
C2	1.23		1.36	0.048		0.054
D	8.95		9.35	0.352		0.368
D1		8			0.315	
E	10		10.4	0.394		0.409
E1		8.5			0.335	
G	4.88		5.28	0.192		0.208
L	15		15.85	0.591		0.624
L2	1.27		1.4	0.050		0.055
M	2.4		3.2	0.094		0.126
R		0.4			0.016	
V2	0°		8°	0°		8°

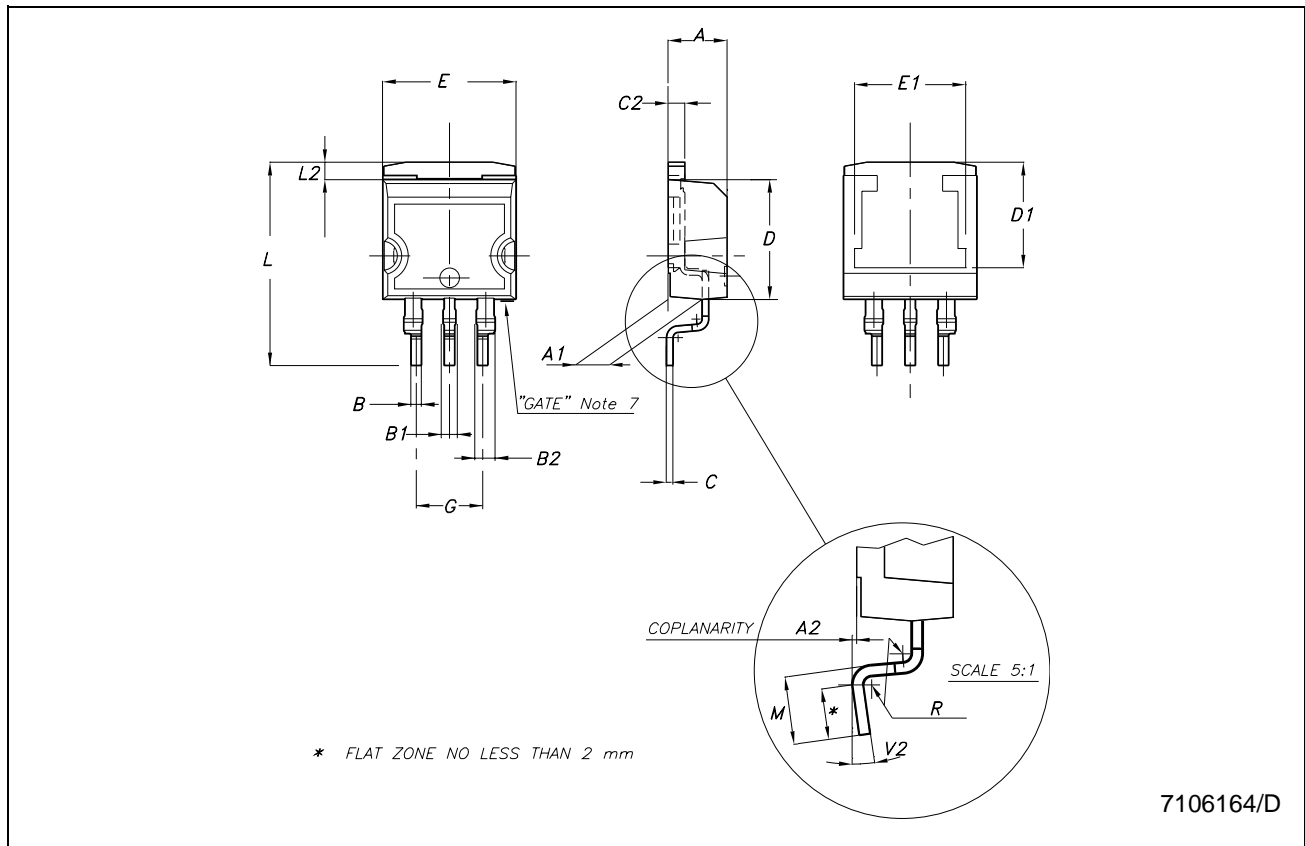

7106164/D

Tape & Reel SOT223 MECHANICAL DATA

DIM.	mm.			inch		
	MIN.	TYP	MAX.	MIN.	TYP.	MAX.
A			330			12.992
C	12.8	13.0	13.2	0.504	0.512	0.519
D	20.2			0.795		
N	60			2.362		
T			14.4			0.567
Ao	6.73	6.83	6.93	0.265	0.269	0.273
Bo	7.32	7.42	7.52	0.288	0.292	0.296
Ko	1.78		2	0.070		0.078
Po	3.9	4.0	4.1	0.153	0.157	0.161
P	7.9	8.0	8.1	0.311	0.315	0.319

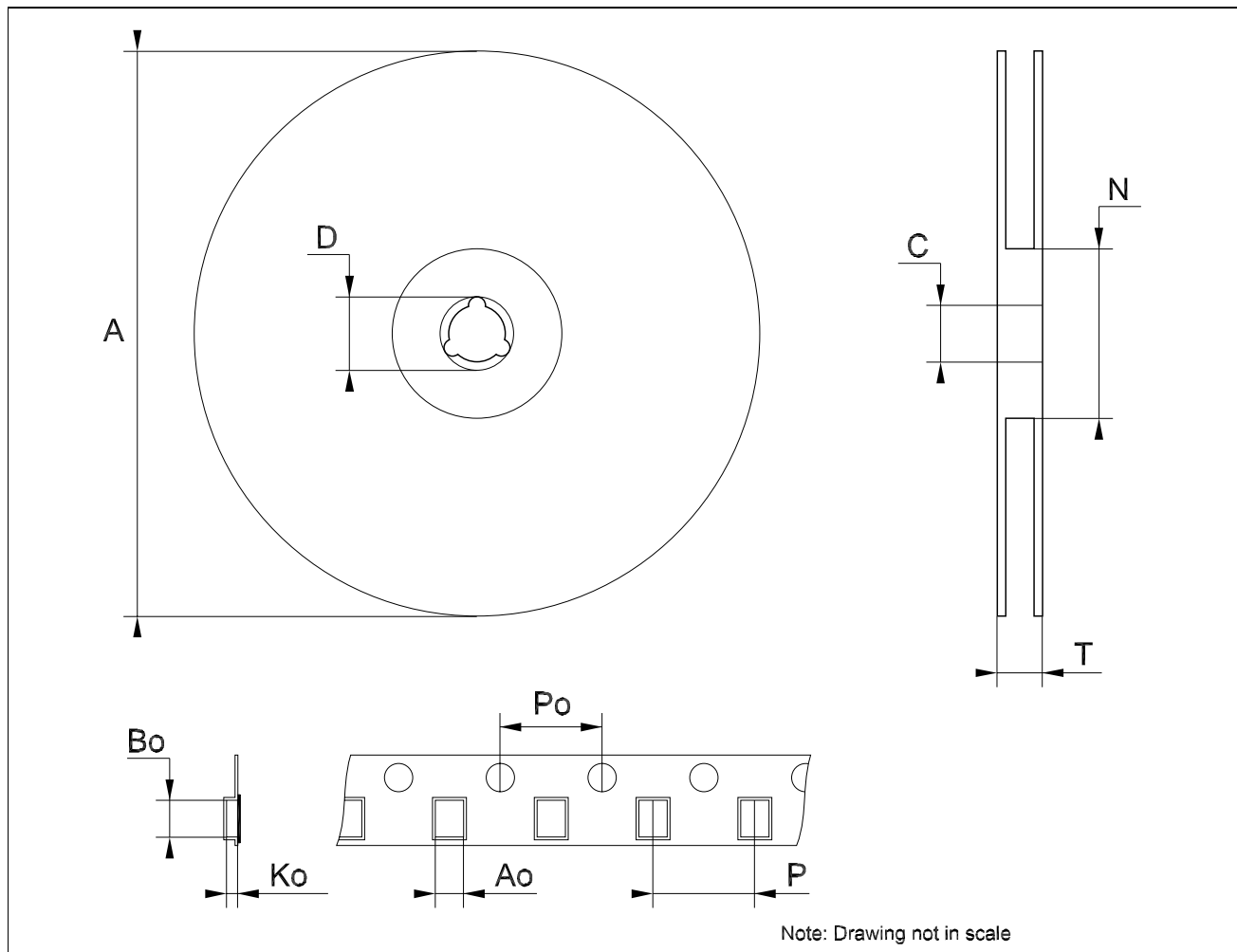

Tape & Reel DPAK-PPAK MECHANICAL DATA

DIM.	mm.			inch		
	MIN.	TYP	MAX.	MIN.	TYP.	MAX.
A			330			12.992
C	12.8	13.0	13.2	0.504	0.512	0.519
D	20.2			0.795		
N	60			2.362		
T			22.4			0.882
Ao	6.80	6.90	7.00	0.268	0.272	0.276
Bo	10.40	10.50	10.60	0.409	0.413	0.417
Ko	2.55	2.65	2.75	0.100	0.104	0.105
Po	3.9	4.0	4.1	0.153	0.157	0.161
P	7.9	8.0	8.1	0.311	0.315	0.319

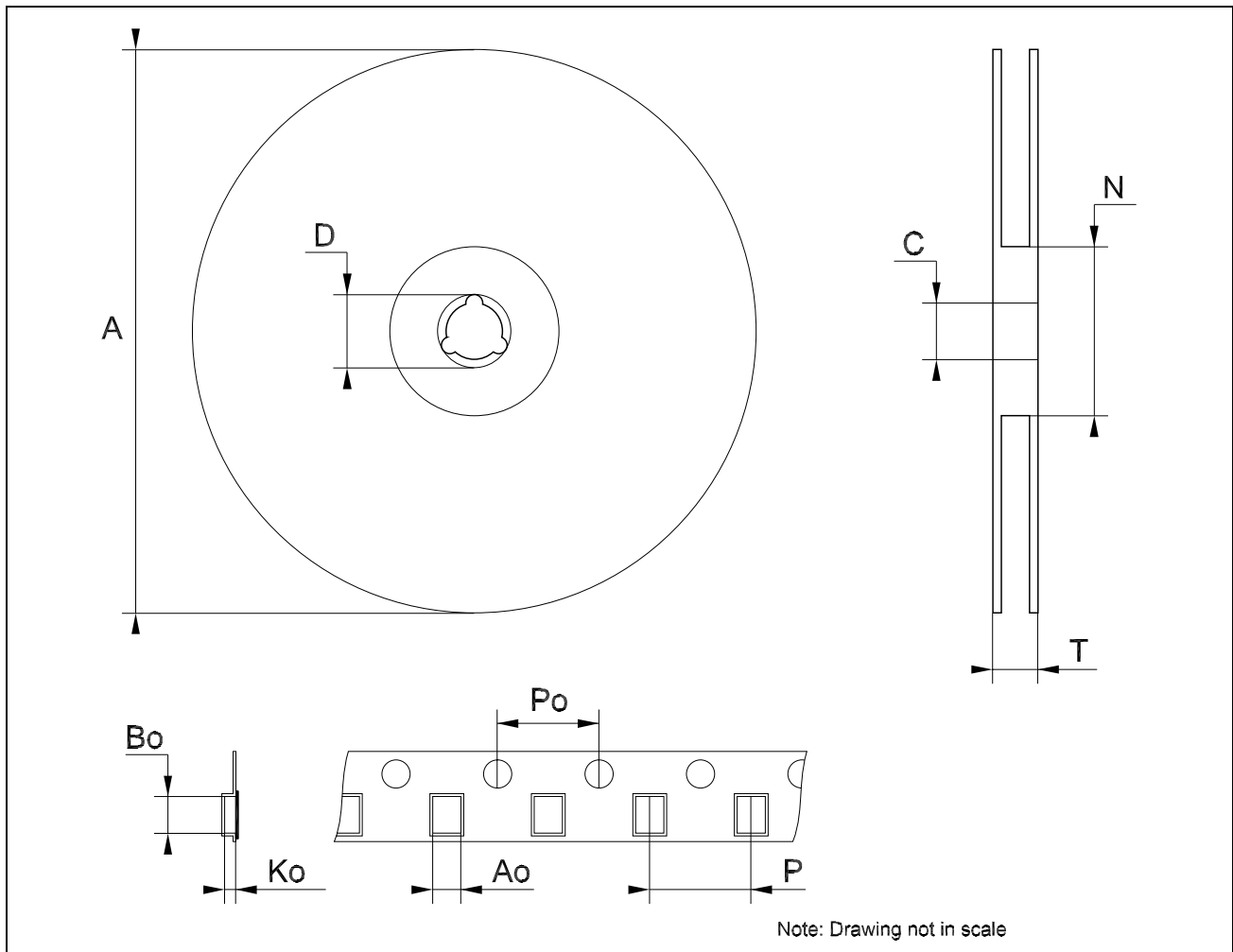

Tape & Reel D²PAK-P²PAK-D²PAK/A-P²PAK/A MECHANICAL DATA

DIM.	mm.			inch		
	MIN.	TYP	MAX.	MIN.	TYP.	MAX.
A			180			7.086
C	12.8	13.0	13.2	0.504	0.512	0.519
D	20.2			0.795		
N	60			2.362		
T			14.4			0.567
Ao	10.50	10.6	10.70	0.413	0.417	0.421
Bo	15.70	15.80	15.90	0.618	0.622	0.626
Ko	4.80	4.90	5.00	0.189	0.193	0.197
Po	3.9	4.0	4.1	0.153	0.157	0.161
P	11.9	12.0	12.1	0.468	0.472	0.476

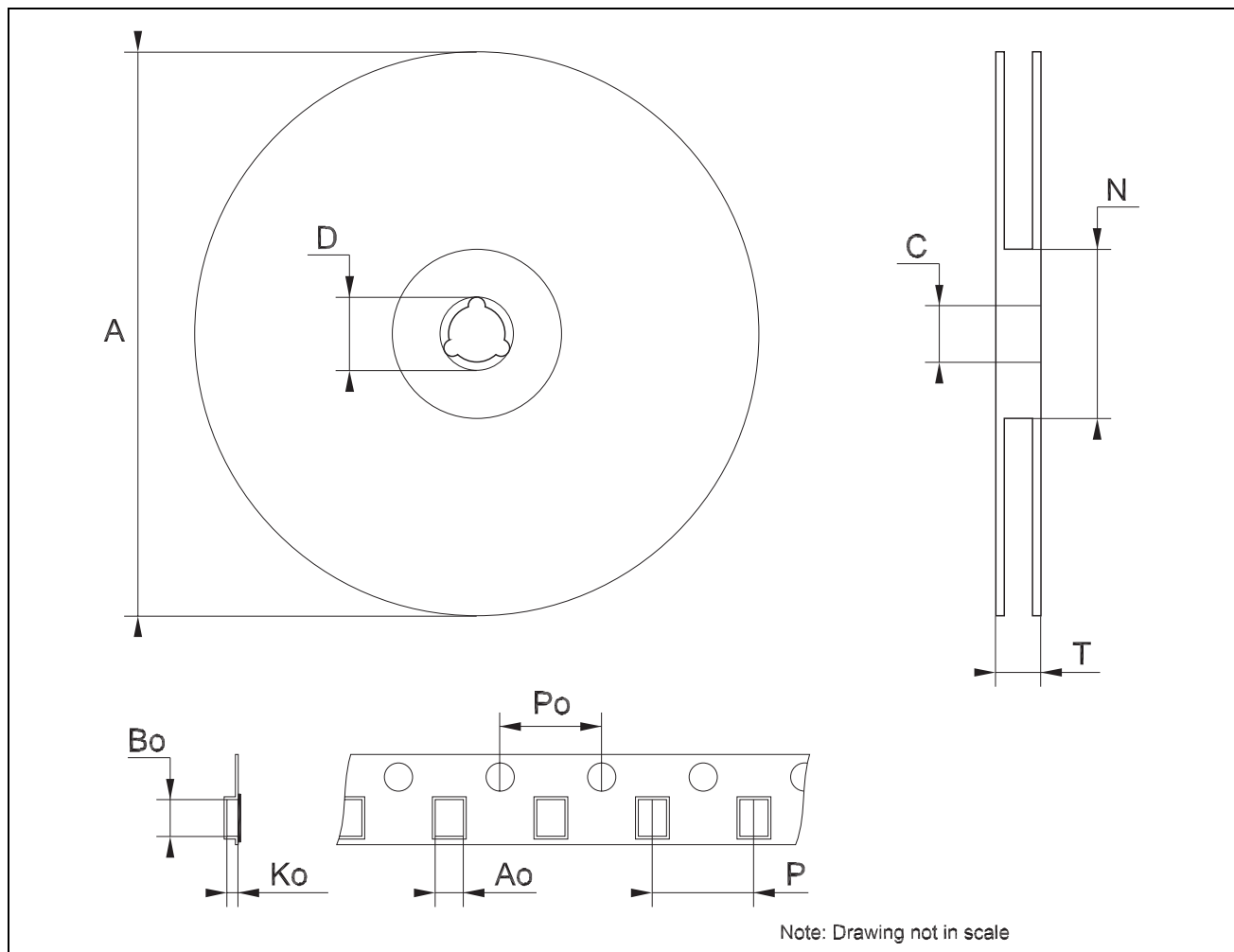

Table 11: Revision History

Date	Revision	Description of Changes
29-Sep-2004	11	Add new Part Number #12.
12-Oct-2004	12	Mistake V_O max. - Table 4.
21-Apr-2005	13	Add new package - D ² PAK/A.
05-Jul-2005	14	The DPAK Mechanical Data has been updated.

Information furnished is believed to be accurate and reliable. However, STMicroelectronics assumes no responsibility for the consequences of use of such information nor for any infringement of patents or other rights of third parties which may result from its use. No license is granted by implication or otherwise under any patent or patent rights of STMicroelectronics. Specifications mentioned in this publication are subject to change without notice. This publication supersedes and replaces all information previously supplied. STMicroelectronics products are not authorized for use as critical components in life support devices or systems without express written approval of STMicroelectronics.

The ST logo is a registered trademark of STMicroelectronics

All other names are the property of their respective owners

© 2005 STMicroelectronics - All Rights Reserved

STMicroelectronics group of companies

Australia - Belgium - Brazil - Canada - China - Czech Republic - Finland - France - Germany - Hong Kong - India - Israel - Italy - Japan -
Malaysia - Malta - Morocco - Singapore - Spain - Sweden - Switzerland - United Kingdom - United States of America

www.st.com

