

FEATURES

- 3-Terminal Adjustable
- Output Current of 3A, 5A or 7.5A
- Operates Down to 1V Dropout
- Guaranteed Dropout Voltage at Multiple Current Levels
- Line Regulation: 0.015%
- Load Regulation: 0.1%
- 100% Thermal Limit Functional Test
- Fixed Versions Available
- Available in 3-Lead Plastic TO-220, TO-3P and DD Packages

APPLICATIONS

- High Efficiency Linear Regulators
- Post Regulators for Switching Supplies
- Constant Current Regulators
- Battery Chargers

| DEVICE | OUTPUT CURRENT* |
|--------|-----------------|
| LT1083 | 7.5A |
| LT1084 | 5.0A |
| LT1085 | 3.0A |

*For a 1.5A low dropout regulator see the LT1086 data sheet.

DESCRIPTION

The LT[®]1083 series of positive adjustable regulators are designed to provide 7.5A, 5A and 3A with higher efficiency than currently available devices. All internal circuitry is designed to operate down to 1V input-to-output differential and the dropout voltage is fully specified as a function of load current. Dropout is guaranteed at a maximum of 1.5V at maximum output current, decreasing at lower load currents. On-chip trimming adjusts the reference voltage to 1%. Current limit is also trimmed, minimizing the stress on both the regulator and power source circuitry under overload conditions.

The LT1083/LT1084/LT1085 devices are pin compatible with older 3-terminal regulators. A 10 μ F output capacitor is required on these new devices. However, this is included in most regulator designs.

Unlike PNP regulators, where up to 10% of the output current is wasted as quiescent current, the LT1083 quiescent current flows into the load, increasing efficiency.

LT, LT, LTM and LTM are registered trademarks of Linear Technology Corporation. All other trademarks are the property of their respective owners.

TYPICAL APPLICATION

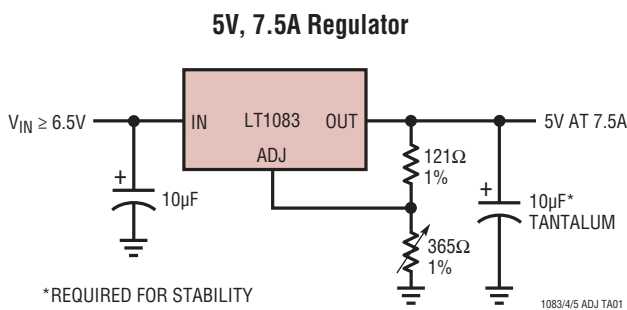

Dropout Voltage vs Output Current

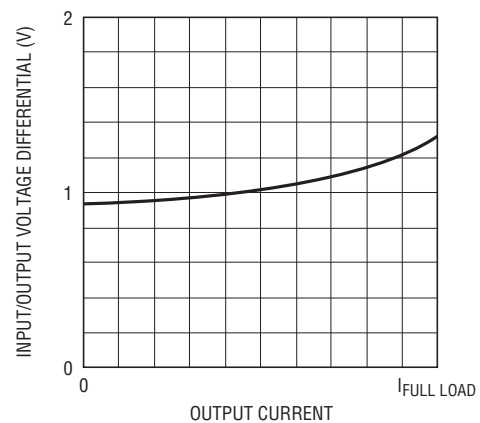

LT1083/LT1084/LT1085

ABSOLUTE MAXIMUM RATINGS (Note 1)

| | |
|---|--------------------|
| Power Dissipation | Internally Limited |
| Input-to-Output Voltage Differential | |
| C-Grades | 30V |
| I-Grades | 30V |
| M-Grades (OBSELETE) | 35V |
| Operating Junction Temperature Range (Note 9) | |
| C-Grades: Control Section | 0°C to 125°C |
| Power Transistor | 0°C to 150°C |
| I-Grades: Control Section | -40°C to 125°C |
| Power Transistor | -40°C to 150°C |

| | |
|--|----------------|
| M-Grades: (OBSELETE) | |
| Control Section | -55°C to 150°C |
| Power Transistor | -55°C to 200°C |
| Storage Temperature Range | -65°C to 150°C |
| Lead Temperature (Soldering, 10 sec) | 300°C |

PRECONDITIONING

100% thermal shutdown functional test.

PIN CONFIGURATION

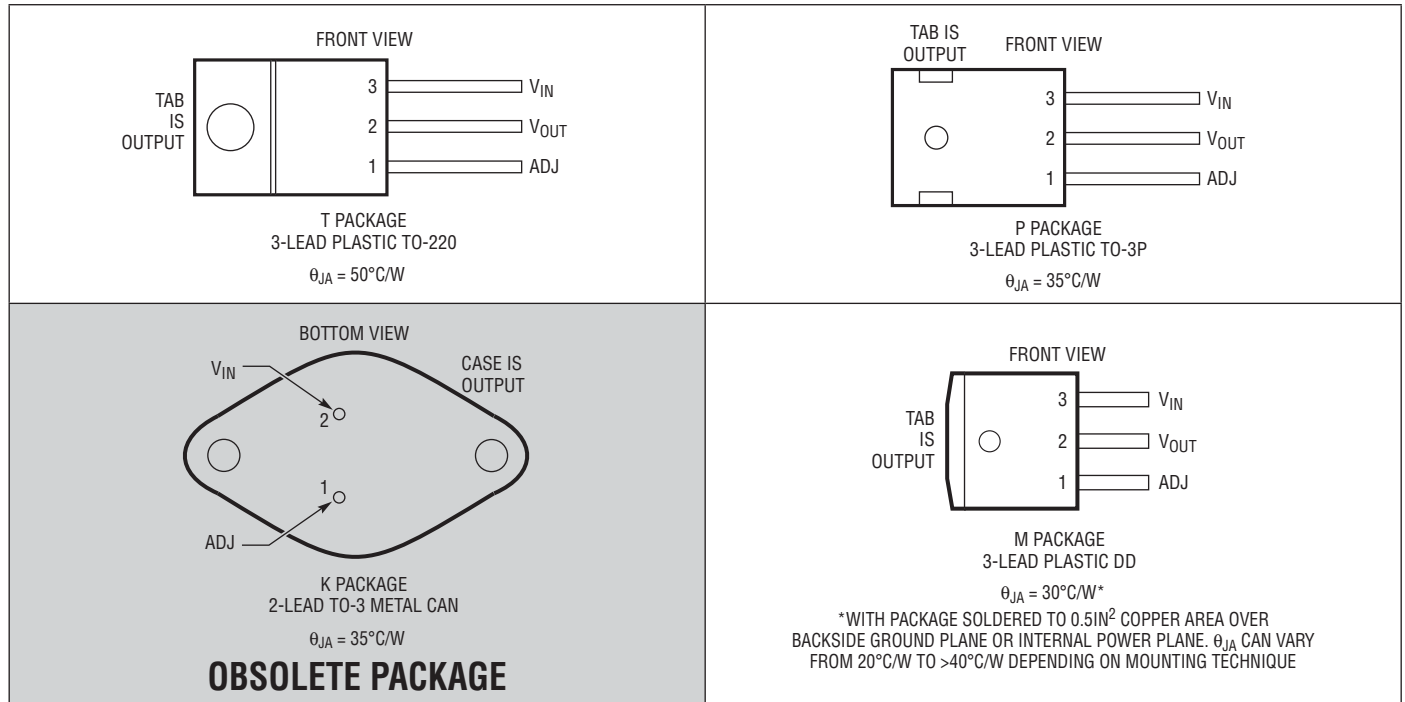

ORDER INFORMATION

| LEAD FREE FINISH | TAPE AND REEL | PART MARKING* | PACKAGE DESCRIPTION | TEMPERATURE RANGE |
|-------------------|----------------|---------------|-----------------------|--|
| LT1083CP#PBF | LT1083CP#TRPBF | LT1083CP | 3-Lead Plastic TO-3P | Control: 0°C to 125°C Power: 0°C to 150°C |
| LT1084CP#PBF | LT1084CP#TRPBF | LT1084CP | 3-Lead Plastic TO-3P | Control: 0°C to 125°C Power: 0°C to 150°C |
| LT1084CT#PBF | LT1084CT#TRPBF | LT1084CT | 3-Lead Plastic TO-220 | Control: 0°C to 125°C Power: 0°C to 150°C |
| LT1084IT#PBF | LT1084IT#TRPBF | LT1084IT | 3-Lead Plastic TO-220 | Control: -40°C to 125°C Power: -40°C to 150°C |
| LT1085CT#PBF | LT1085CT#TRPBF | LT1085CT | 3-Lead Plastic TO-220 | Control: 0°C to 125°C Power: 0°C to 150°C |
| LT1085IT#PBF | LT1085IT#TRPBF | LT1085IT | 3-Lead Plastic TO-220 | Control: -40°C to 125°C Power: -40°C to 150°C |
| LT1085CM#PBF | LT1085CM#TRPBF | LT1085CM | 3-Lead Plastic DD | Control: 0°C to 125°C Power: 0°C to 150°C |
| LT1085IM#PBF | LT1085IM#TRPBF | LT1085IM | 3-Lead Plastic DD | Control: -40°C to 125°C Power: -40°C to 150°C |
| LEAD BASED FINISH | TAPE AND REEL | PART MARKING* | PACKAGE DESCRIPTION | TEMPERATURE RANGE |
| LT1083CP | LT1083CP#TR | LT1083CP | 3-Lead Plastic TO-3P | Control: 0°C to 125°C Power: 0°C to 150°C |
| LT1084CP | LT1084CP#TR | LT1084CP | 3-Lead Plastic TO-3P | Control: 0°C to 125°C Power: 0°C to 150°C |
| LT1084CT | LT1084CT#TR | LT1084CT | 3-Lead Plastic TO-220 | Control: 0°C to 125°C Power: 0°C to 150°C |
| LT1084IT | LT1084IT#TR | LT1084IT | 3-Lead Plastic TO-220 | Control: -40°C to 125°C Power: -40°C to 150°C |
| LT1085CT | LT1085CT#TR | LT1085CT | 3-Lead Plastic TO-220 | Control: 0°C to 125°C Power: 0°C to 150°C |
| LT1085IT | LT1085IT#TR | LT1085IT | 3-Lead Plastic TO-220 | Control: -40°C to 125°C Power: -40°C to 150°C |
| LT1085CM | LT1085CM#TR | LT1085CM | 3-Lead Plastic DD | Control: 0°C to 125°C Power: 0°C to 150°C |
| LT1085IM | LT1085IM#TR | LT1085IM | 3-Lead Plastic DD | Control: -40°C to 125°C Power: -40°C to 150°C |
| LT1083CK | LT1083CK#TR | LT1083CK | 2-Lead TO-3 Metal Can | Control: 0°C to 125°C Power: 0°C to 150°C |
| LT1083MK | LT1083MK#TR | LT1083MK | 2-Lead TO-3 Metal Can | Control: -55°C to 150°C Power: -55°C to 200°C |
| LT1084CK | LT1084CK#TR | LT1084CK | 2-Lead TO-3 Metal Can | Control: 0°C to 125°C Power: 0°C to 150°C |
| LT1084MK | LT1084MK#TR | LT1084MK | 2-Lead TO-3 Metal Can | Control: -55°C to 150°C Power: -55°C to 200°C |
| LT1085CK | LT1085CK#TR | LT1085CK | 2-Lead TO-3 Metal Can | Control: 0°C to 125°C Power: 0°C to 150°C |
| LT1085MK | LT1085MK#TR | LT1085MK | 2-Lead TO-3 Metal Can | Control: -55°C to 150°C Power: -55°C to 200°C |

OBSOLETE PACKAGE

Consult LTC Marketing for parts specified with wider operating temperature ranges. *The temperature grade is identified by a label on the shipping container.

For more information on lead free part marking, go to: <http://www.linear.com/leadfree/>

For more information on tape and reel specifications, go to: <http://www.linear.com/tapeandreeel/>

LT1083/LT1084/LT1085

ELECTRICAL CHARACTERISTICS The ● denotes the specifications which apply over the full operating temperature range, otherwise specifications are at $T_A = 25^\circ\text{C}$.

| PARAMETER | CONDITIONS | MIN | TYP | MAX | UNITS |
|------------------------------------|---|--------|-------|-------|---------------|
| Reference Voltage | $I_{OUT} = 10\text{mA}$, $T_J = 25^\circ\text{C}$, $(V_{IN} - V_{OUT}) = 3\text{V}$ $10\text{mA} \leq I_{OUT} \leq I_{FULL_LOAD}$ $1.5\text{V} \leq (V_{IN} - V_{OUT}) \leq 25\text{V}$ (Notes 4, 6, 7) | 1.238 | 1.250 | 1.262 | V |
| | ● | 1.225 | 1.250 | 1.270 | V |
| Line Regulation | $I_{LOAD} = 10\text{mA}$, $1.5\text{V} \leq (V_{IN} - V_{OUT}) \leq 15\text{V}$, $T_J = 25^\circ\text{C}$ (Notes 2, 3) | ● | 0.015 | 0.2 | % |
| | ● | 0.035 | 0.2 | % | |
| | M-Grade: $15\text{V} \leq (V_{IN} - V_{OUT}) \leq 35\text{V}$ (Notes 2, 3) | ● | 0.05 | 0.5 | % |
| | C-, I-Grades: $15\text{V} \leq (V_{IN} - V_{OUT}) \leq 30\text{V}$ (Notes 2, 3) | ● | 0.05 | 0.5 | % |
| Load Regulation | $(V_{IN} - V_{OUT}) = 3\text{V}$, $10\text{mA} \leq I_{OUT} \leq I_{FULL_LOAD}$, $T_J = 25^\circ\text{C}$ (Notes 2, 3, 4, 6) | ● | 0.1 | 0.3 | % |
| | ● | 0.2 | 0.4 | % | |
| Dropout Voltage | $\Delta V_{REF} = 1\%$, $I_{OUT} = I_{FULL_LOAD}$ (Notes 5, 6, 8) | ● | 1.3 | 1.5 | V |
| Current Limit | LT1083 $(V_{IN} - V_{OUT}) = 5\text{V}$ | ● | 8.0 | 9.5 | A |
| | ● | 0.4 | 1.0 | A | |
| | LT1084 $(V_{IN} - V_{OUT}) = 5\text{V}$ | ● | 5.5 | 6.5 | A |
| | ● | 0.3 | 0.6 | A | |
| | LT1085 $(V_{IN} - V_{OUT}) = 5\text{V}$ | ● | 3.2 | 4.0 | A |
| | ● | 0.2 | 0.5 | A | |
| Minimum Load Current | $(V_{IN} - V_{OUT}) = 25\text{V}$ | ● | 5 | 10 | mA |
| Thermal Regulation | $T_A = 25^\circ\text{C}$, 30ms Pulse | | 0.002 | 0.010 | %/W |
| | | LT1083 | 0.003 | 0.015 | %/W |
| | | LT1084 | 0.004 | 0.020 | %/W |
| LT1085 | | | | | |
| Ripple Rejection | $f = 120\text{Hz}$, $C_{ADJ} = 25\mu\text{F}$, $C_{OUT} = 25\mu\text{F}$ Tantalum $I_{OUT} = I_{FULL_LOAD}$, $(V_{IN} - V_{OUT}) = 3\text{V}$ (Notes 6, 7, 8) | ● | 60 | 75 | dB |
| Adjust Pin Current | $T_J = 25^\circ\text{C}$ | ● | 55 | | μA |
| | | | | 120 | μA |
| Adjust Pin Current Change | $10\text{mA} \leq I_{OUT} \leq I_{FULL_LOAD}$, $1.5\text{V} \leq (V_{IN} - V_{OUT}) \leq 25\text{V}$ (Note 6) | ● | 0.2 | 5 | μA |
| Temperature Stability | | ● | 0.5 | | % |
| Long-Term Stability | $T_A = 125^\circ\text{C}$, 1000 Hrs | | 0.3 | 1 | % |
| RMS Output Noise (% of V_{OUT}) | $T_A = 25^\circ\text{C}$, $10\text{Hz} \leq f \leq 10\text{kHz}$ | | 0.003 | | % |

ELECTRICAL CHARACTERISTICS The ● denotes the specifications which apply over the full operating temperature range, otherwise specifications are at $T_A = 25^\circ\text{C}$.

| PARAMETER | CONDITIONS | MIN | TYP | MAX | UNITS |
|---|------------------------------------|-----|-----|----------|--------------------|
| Thermal Resistance Junction-to-Case LT1083 | Control Circuitry/Power Transistor | | | | |
| | K Package | | | 0.6/1.6 | $^\circ\text{C/W}$ |
| LT1084 | P Package | | | 0.5/1.6 | $^\circ\text{C/W}$ |
| | K Package | | | 0.75/2.3 | $^\circ\text{C/W}$ |
| LT1085 | P Package | | | 0.65/2.3 | $^\circ\text{C/W}$ |
| | T Package | | | 0.65/2.7 | $^\circ\text{C/W}$ |
| | K Package | | | 0.9/3.0 | $^\circ\text{C/W}$ |
| | M, T Package | | | 0.7/3.0 | $^\circ\text{C/W}$ |

Note 1: Stresses beyond those listed under Absolute Maximum Ratings may cause permanent damage to the device. Exposure to any Absolute Maximum Rating condition for extended periods may affect device reliability and lifetime.

Note 2: See thermal regulation specifications for changes in output voltage due to heating effects. Load and line regulation are measured at a constant junction temperature by low duty cycle pulse testing.

Note 3: Line and load regulation are guaranteed up to the maximum power dissipation (60W for the LT1083, 45W for the LT1084 (K, P), 30W for the LT1084 (T) and 30W for the LT1085). Power dissipation is determined by the input/output differential and the output current. Guaranteed maximum power dissipation will not be available over the full input/output voltage range.

Note 4: $I_{\text{FULL_LOAD}}$ is defined in the current limit curves. The $I_{\text{FULL_LOAD}}$ curve is defined as the minimum value of current limit as a function of input-to-output voltage. Note that the 60W power dissipation for the LT1083 (45W for the LT1084 (K, P), 30W for the LT1084 (T), 30W for the LT1085) is only achievable over a limited range of input-to-output voltage.

Note 5: Dropout voltage is specified over the full output current range of the device. Test points and limits are shown on the Dropout Voltage curve.

Note 6: For LT1083 $I_{\text{FULL_LOAD}}$ is 5A for $-55^\circ\text{C} \leq T_J < -40^\circ\text{C}$ and 7.5A for $T_J \geq -40^\circ\text{C}$.

Note 7: $1.7\text{V} \leq (V_{\text{IN}} - V_{\text{OUT}}) \leq 25\text{V}$ for LT1084 at $-55^\circ\text{C} \leq T_J \leq -40^\circ\text{C}$.

Note 8: Dropout is 1.7V maximum for LT1084 at $-55^\circ\text{C} \leq T_J \leq -40^\circ\text{C}$.

Note 9: The LT1083/LT1084/LT1085 regulators are tested and specified under pulse load conditions such that $T_J \cong T_A$. The C-grade LT1083/LT1084/LT1085 are 100% tested at 25°C . The I-grade LT1084/LT1085 are guaranteed over the full -40°C to 125°C operating ambient temperature range.

TYPICAL PERFORMANCE CHARACTERISTICS

LT1083
Dropout Voltage

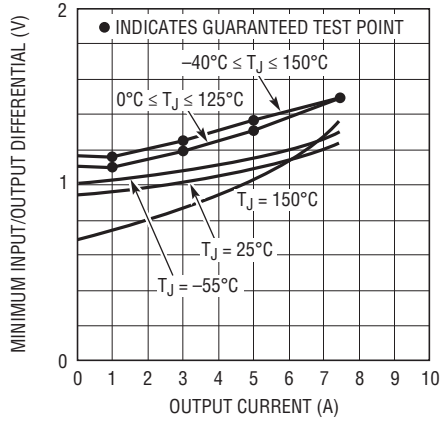

LT1083
Short-Circuit Current

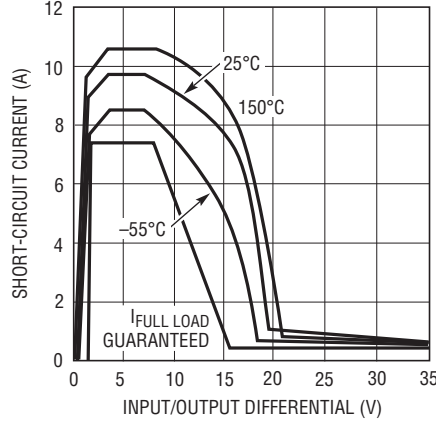

LT1083
Load Regulation

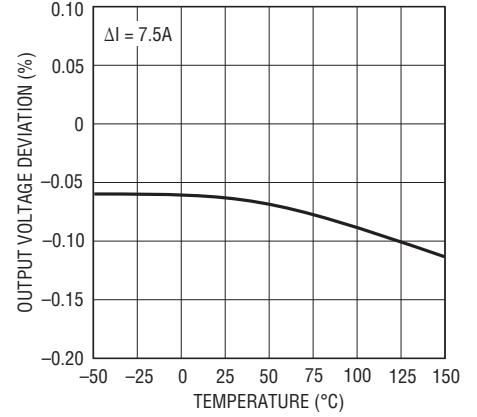

LT1084
Dropout Voltage

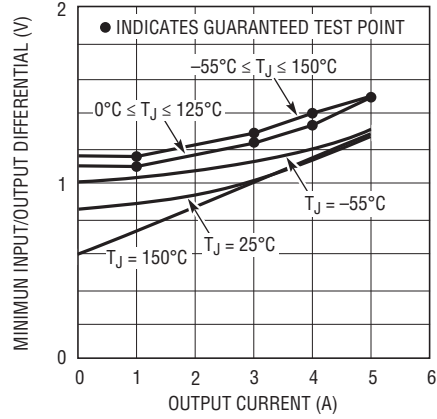

LT1084
Short-Circuit Current

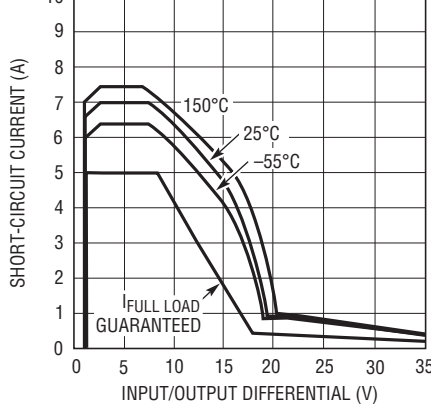

LT1084
Load Regulation

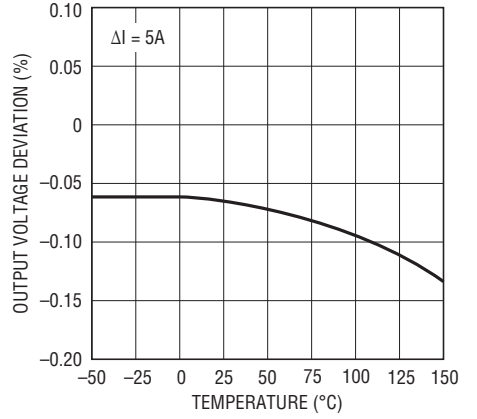

LT1085
Dropout Voltage

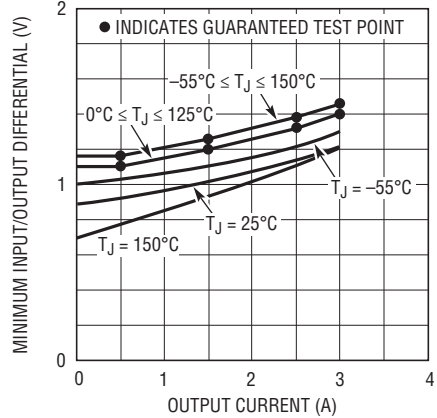

LT1085
Short-Circuit Current

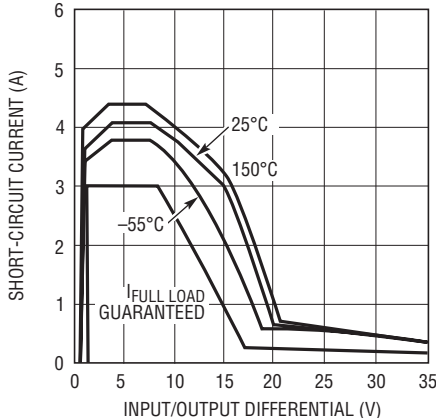

LT1085
Load Regulation

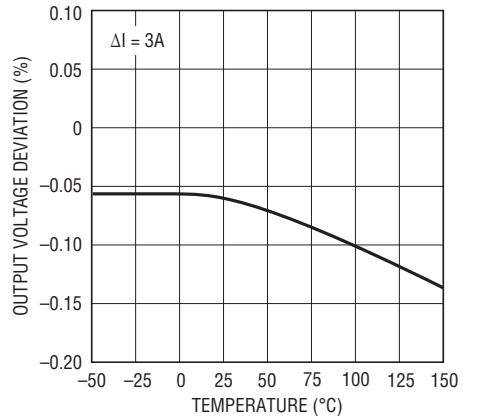

TYPICAL PERFORMANCE CHARACTERISTICS

Minimum Operating Current

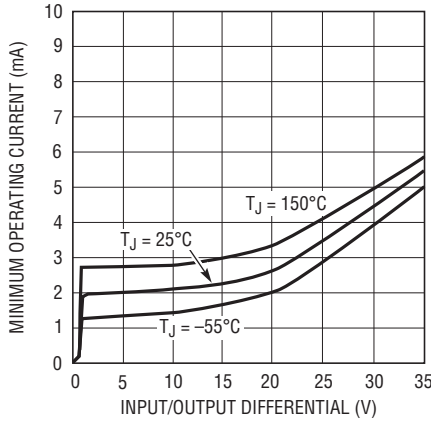

LT1083/4/5 ADJ G10

Temperature Stability

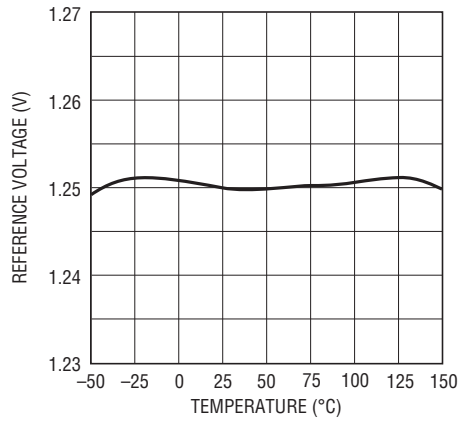

LT1083/4/5 ADJ G11

Adjust Pin Current

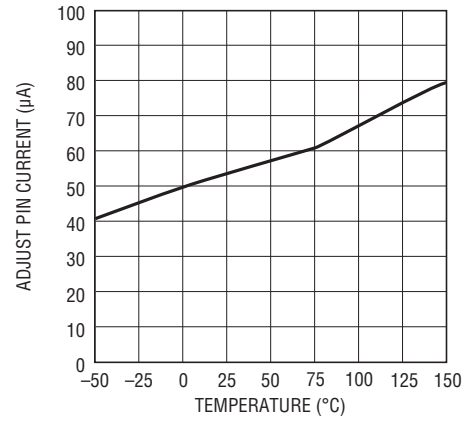

LT1083/4/5 ADJ G12

**LT1083
Ripple Rejection**

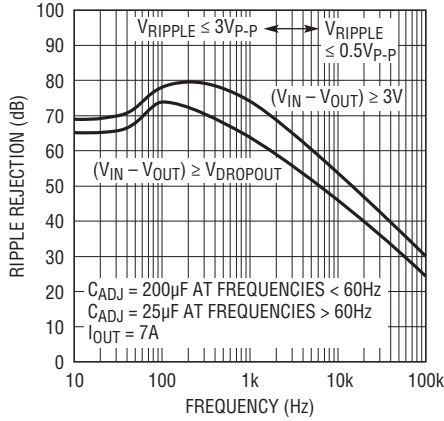

1083/4/5 ADJ G13

**LT1083
Ripple Rejection vs Current**

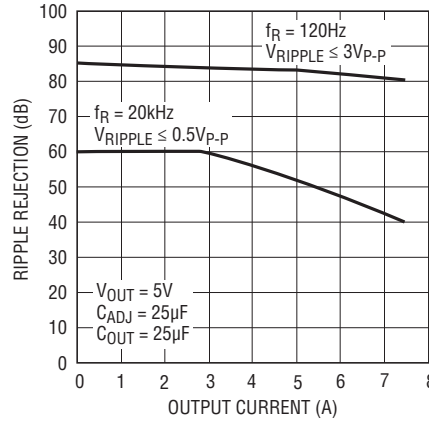

1083/4/5 ADJ G14

**LT1083
Maximum Power Dissipation***

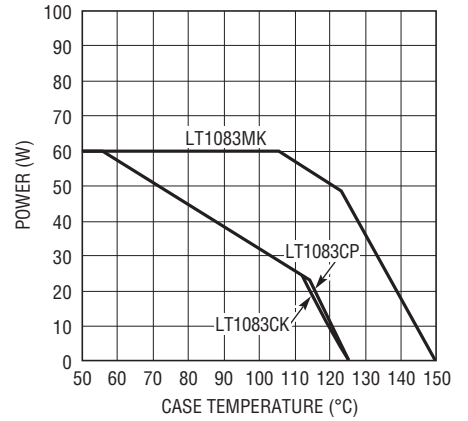

* AS LIMITED BY MAXIMUM JUNCTION TEMPERATURE
LT1083/4/5 ADJ G15

**LT1084
Ripple Rejection**

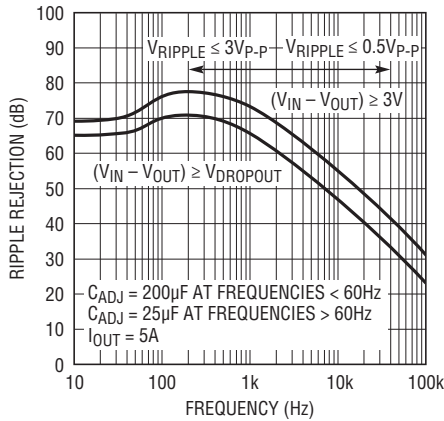

1083/4/5 ADJ G16

**LT1084
Ripple Rejection vs Current**

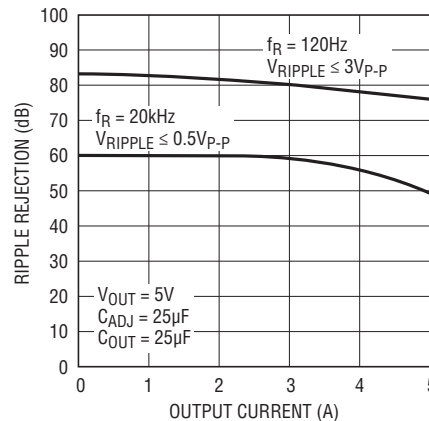

1083/4/5 ADJ G17

**LT1084
Maximum Power Dissipation***

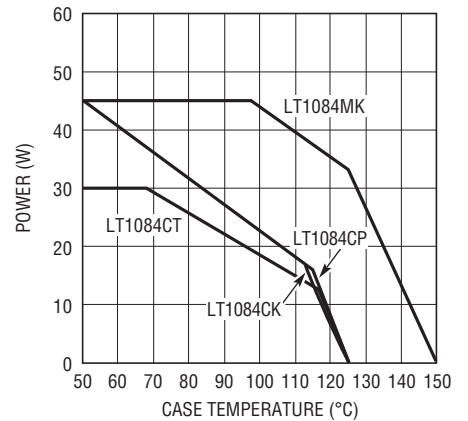

* AS LIMITED BY MAXIMUM JUNCTION TEMPERATURE
LT1083/4/5 ADJ G18

TYPICAL PERFORMANCE CHARACTERISTICS

LT1085
Ripple Rejection

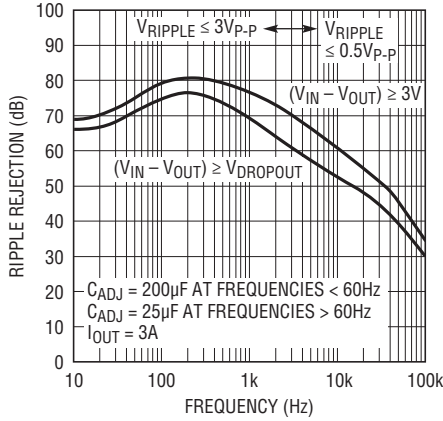

1083/4/5 ADJ G19

LT1085
Ripple Rejection vs Current

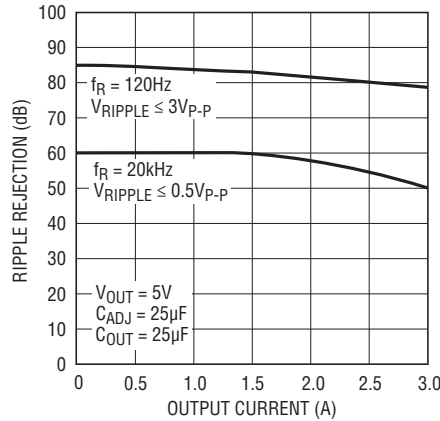

1083/4/5 ADJ G20

LT1085
Maximum Power Dissipation*

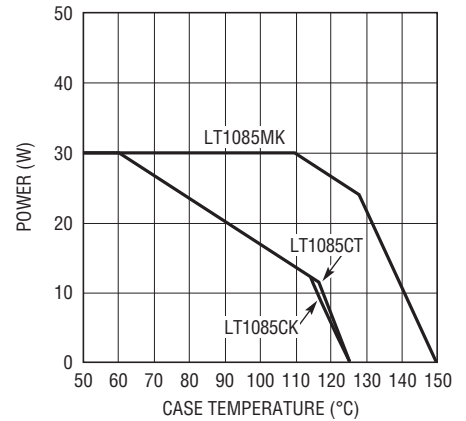

* AS LIMITED BY MAXIMUM JUNCTION TEMPERATURE
LT1083/4/5 ADJ G21

LT1083
Load Transient Response

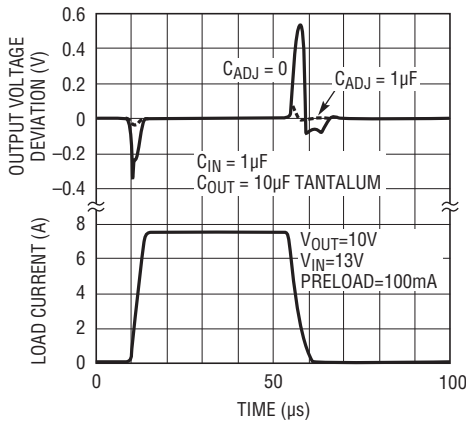

1083/4/5 ADJ G22

LT1084
Load Transient Response

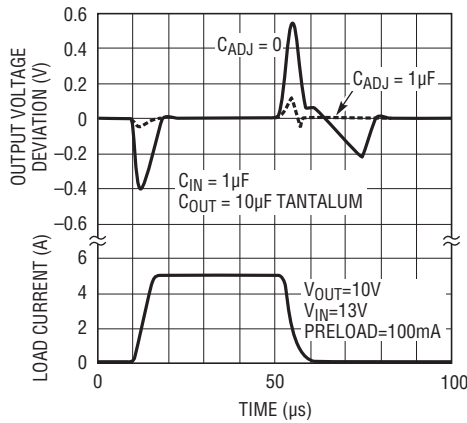

1083/4/5 ADJ G23

LT1085
Load Transient Response

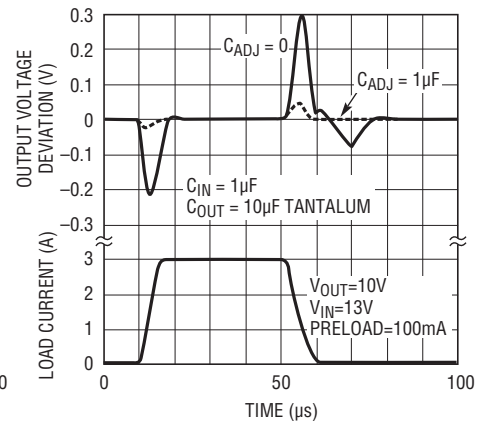

1083/4/5 ADJ G24

LT1083
Line Transient Response

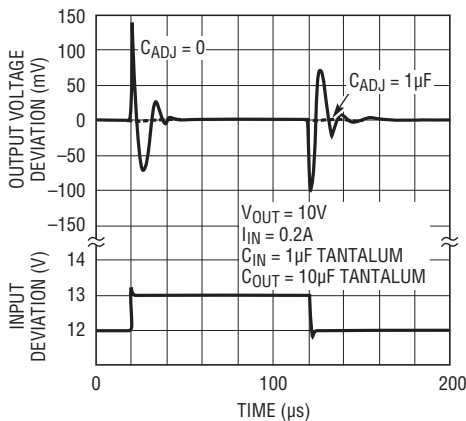

1083/4/5 ADJ G25

LT1084
Line Transient Response

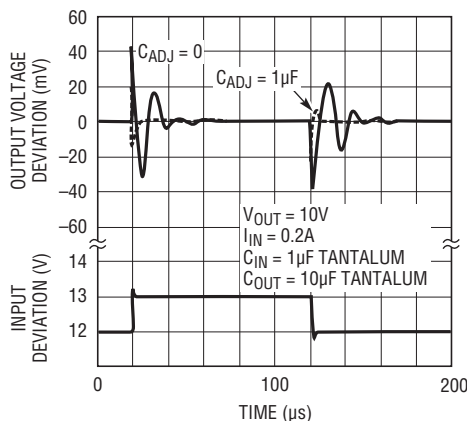

1083/4/5 ADJ G26

LT1085
Line Transient Response

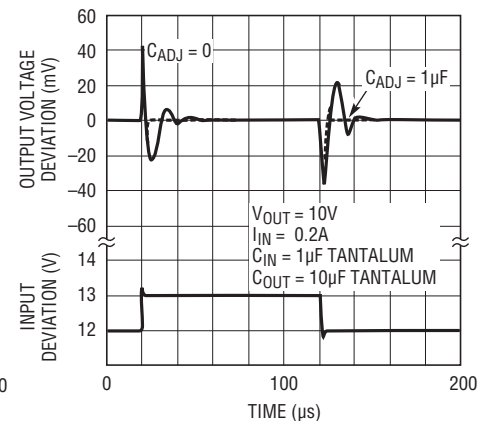

1083/4/5 ADJ G27

BLOCK DIAGRAM

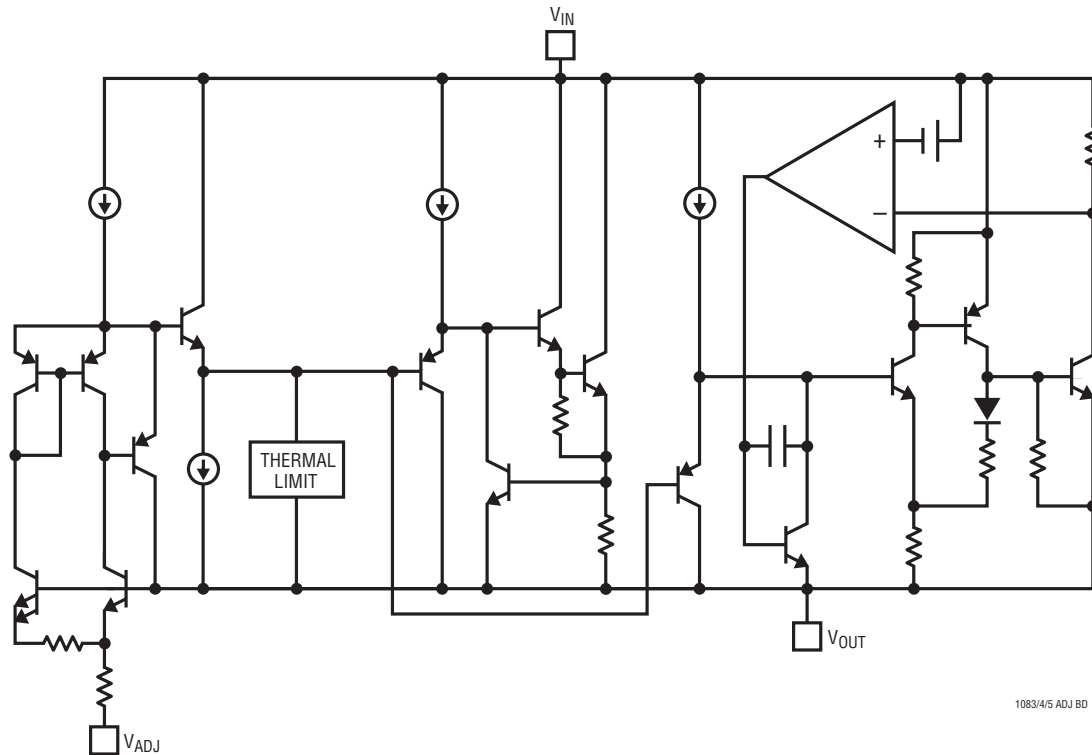

1083/4/5 ADJ BD

APPLICATIONS INFORMATION

The LT1083 family of 3-terminal adjustable regulators is easy to use and has all the protection features that are expected in high performance voltage regulators. They are short-circuit protected, and have safe area protection as well as thermal shutdown to turn off the regulator should the junction temperature exceed about 165°C.

These regulators are pin compatible with older 3-terminal adjustable devices, offer lower dropout voltage and more precise reference tolerance. Further, the reference stability with temperature is improved over older types of regulators. The only circuit difference between using the LT1083 family and older regulators is that this new family requires an output capacitor for stability.

Stability

The circuit design used in the LT1083 family requires the use of an output capacitor as part of the device frequency compensation. For all operating conditions, the addition of a 150µF aluminium electrolytic or a 22µF solid tantalum

on the output will ensure stability. Normally, capacitors much smaller than this can be used with the LT1083. Many different types of capacitors with widely varying characteristics are available. These capacitors differ in capacitor tolerance (sometimes ranging up to ±100%), equivalent series resistance, and capacitance temperature coefficient. The 150µF or 22µF values given will ensure stability.

When the adjustment terminal is bypassed to improve the ripple rejection, the requirement for an output capacitor increases. The value of 22µF tantalum or 150µF aluminium covers all cases of bypassing the adjustment terminal. Without bypassing the adjustment terminal, smaller capacitors can be used with equally good results and the table below shows approximately what size capacitors are needed to ensure stability.

Recommended Capacitor Values

| INPUT | OUTPUT | ADJUSTMENT |
|--------------|---|--------------|
| 10µF 10µF | 10µF Tantalum, 50µF Aluminium 22µF Tantalum, 150µF Aluminium | None 20µF |

APPLICATIONS INFORMATION

Normally, capacitor values on the order of 100 μ F are used in the output of many regulators to ensure good transient response with heavy load current changes. Output capacitance can be increased without limit and larger values of output capacitor further improve stability and transient response of the LT1083 regulators.

Another possible stability problem that can occur in monolithic IC regulators is current limit oscillations. These can occur because, in current limit, the safe area protection exhibits a negative impedance. The safe area protection decreases the current limit as the input-to-output voltage increases. That is the equivalent of having a negative resistance since increasing voltage causes current to decrease. Negative resistance during current limit is not unique to the LT1083 series and has been present on all power IC regulators. The value of the negative resistance is a function of how fast the current limit is folded back as input-to-output voltage increases. This negative resistance can react with capacitors or inductors on the input to cause oscillation during current limiting. Depending on the value of series resistance, the overall circuitry may end up unstable. Since this is a system problem, it is not necessarily easy to solve; however, it does not cause any problems with the IC regulator and can usually be ignored.

Protection Diodes

In normal operation, the LT1083 family does not need any protection diodes. Older adjustable regulators required protection diodes between the adjustment pin and the output and from the output to the input to prevent overstressing the die. The internal current paths on the LT1083 adjustment pin are limited by internal resistors. Therefore, even with capacitors on the adjustment pin, no protection diode is needed to ensure device safety under short-circuit conditions.

Diodes between input and output are usually not needed. The internal diode between the input and the output pins of the LT1083 family can handle microsecond surge currents of 50A to 100A. Even with large output capacitances, it is very difficult to get those values of surge currents in normal operations. Only with a high value of output capacitors, such as 1000 μ F to 5000 μ F and with the input

pin instantaneously shorted to ground, can damage occur. A crowbar circuit at the input of the LT1083 can generate those kinds of currents, and a diode from output to input is then recommended. Normal power supply cycling or even plugging and unplugging in the system will not generate current large enough to do any damage.

The adjustment pin can be driven on a transient basis ± 25 V, with respect to the output without any device degradation. Of course, as with any IC regulator, exceeding the maximum input to output voltage differential causes the internal transistors to break down and none of the protection circuitry is functional.

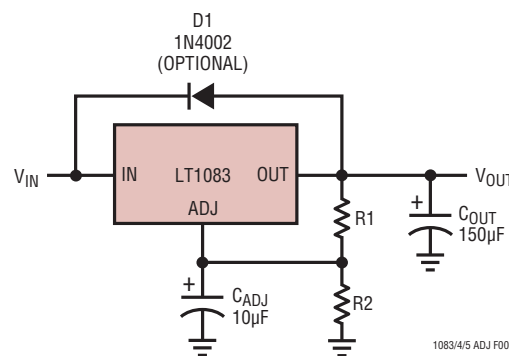

Overload Recovery

Like any of the IC power regulators, the LT1083 has safe area protection. The safe area protection decreases the current limit as input-to-output voltage increases and keeps the power transistor inside a safe operating region for all values of input-to-output voltage. The LT1083 protection is designed to provide some output current at all values of input-to-output voltage up to the device breakdown.

When power is first turned on, as the input voltage rises, the output follows the input, allowing the regulator to start up into very heavy loads. During the start-up, as the input voltage is rising, the input-to-output voltage differential remains small, allowing the regulator to supply large output currents. With high input voltage, a problem can occur wherein removal of an output short will not allow the output voltage to recover. Older regulators, such as the 7800 series, also exhibited this phenomenon, so it is not unique to the LT1083.

APPLICATIONS INFORMATION

The problem occurs with a heavy output load when the input voltage is high and the output voltage is low, such as immediately after removal of a short. The load line for such a load may intersect the output current curve at two points. If this happens, there are two stable output operating points for the regulator. With this double intersection, the power supply may need to be cycled down to zero and brought up again to make the output recover.

Ripple Rejection

The typical curves for ripple rejection reflect values for a bypassed adjustment pin. This curve will be true for all values of output voltage. For proper bypassing and ripple rejection approaching the values shown, the impedance of the adjust pin capacitor at the ripple frequency should be less than the value of R1, (normally 100Ω to 120Ω). The size of the required adjust pin capacitor is a function of the input ripple frequency. At 120Hz the adjust pin capacitor should be 25μF if R1 = 100Ω. At 10kHz only 0.22μF is needed.

For circuits without an adjust pin bypass capacitor, the ripple rejection will be a function of output voltage. The output ripple will increase directly as a ratio of the output voltage to the reference voltage (V_{OUT}/V_{REF}). For example, with the output voltage equal to 5V and no adjust pin capacitor, the output ripple will be higher by the ratio of 5V/1.25V or four times larger. Ripple rejection will be degraded by 12dB from the value shown on the typical curve.

Output Voltage

The LT1083 develops a 1.25V reference voltage between the output and the adjust terminal (see Figure 1). By placing a resistor R1 between these two terminals, a constant current is caused to flow through R1 and down through R2 to set the overall output voltage. Normally this current is the specified minimum load current of 10mA. Because I_{ADJ} is very small and constant when compared with the current through R1, it represents a small error and can usually be ignored.

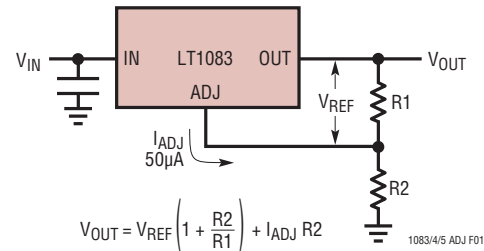

Figure 1. Basic Adjustable Regulator

Load Regulation

Because the LT1083 is a 3-terminal device, it is not possible to provide true remote load sensing. Load regulation will be limited by the resistance of the wire connecting the regulator to the load. The data sheet specification for load regulation is measured at the bottom of the package. Negative side sensing is a true Kelvin connection, with the bottom of the output divider returned to the negative side of the load. Although it may not be immediately obvious, best load regulation is obtained when the top of the resistor divider R1 is connected *directly* to the case *not to the load*. This is illustrated in Figure 2. If R1 were connected to the load, the effective resistance between the regulator and the load would be:

$$R_P \cdot \left(\frac{R_2 + R_1}{R_1} \right), R_P = \text{Parasitic Line Resistance}$$

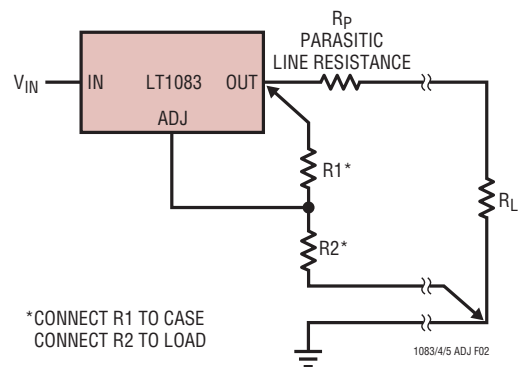

Figure 2. Connections for Best Load Regulation

APPLICATIONS INFORMATION

Connected as shown, R_P is not multiplied by the divider ratio. R_P is about 0.004Ω per foot using 16-gauge wire. This translates to 4mV/ft at 1A load current, so it is important to keep the positive lead between regulator and load as short as possible and use large wire or PC board traces.

Thermal Considerations

The LT1083 series of regulators have internal power and thermal limiting circuitry designed to protect the device under overload conditions. For continuous normal load conditions however, maximum junction temperature ratings must not be exceeded. It is important to give careful consideration to all sources of thermal resistance from junction to ambient. This includes junction-to-case, case-to-heat sink interface, and heat sink resistance itself. New thermal resistance specifications have been developed to more accurately reflect device temperature and ensure safe operating temperatures. The data section for these new regulators provides a separate thermal resistance and maximum junction temperature for both the *Control Section* and the *Power Transistor*. Previous regulators, with a single junction-to-case thermal resistance specification, used an average of the two values provided here and therefore could allow excessive junction temperatures under certain conditions of ambient temperature and heat sink resistance. To avoid this possibility, calculations should be made for both sections to ensure that both thermal limits are met.

Junction-to-case thermal resistance is specified from the IC junction to the bottom of the case directly below the die. This is the lowest resistance path for heat flow. Proper mounting is required to ensure the best possible thermal flow from this area of the package to the heat sink. Thermal

compound at the case-to-heat sink interface is strongly recommended. If the case of the device must be electrically isolated, a thermally conductive spacer can be used, as long as its added contribution to thermal resistance is considered. Note that the case of all devices in this series is electrically connected to the output.

For example, using an LT1083CK (TO-3, Commercial) and assuming:

$$V_{IN} (\text{Max Continuous}) = 9\text{V}, V_{OUT} = 5\text{V}, I_{OUT} = 6\text{A},$$

$$T_A = 75^\circ\text{C}, \theta_{\text{HEAT SINK}} = 1^\circ\text{C/W},$$

$$\theta_{\text{CASE-TO-HEAT SINK}} = 0.2^\circ\text{C/W for K package with thermal compound.}$$

Power dissipation under these conditions is equal to:

$$P_D = (V_{IN} - V_{OUT}) I_{OUT} = 24\text{W}$$

Junction temperature will be equal to:

$$T_J = T_A + P_D (\theta_{\text{HEAT SINK}} + \theta_{\text{CASE-TO-HEAT SINK}} + \theta_{JC})$$

For the Control Section:

$$T_J = 75^\circ\text{C} + 24\text{W} (1^\circ\text{C/W} + 0.2^\circ\text{C/W} + 0.6^\circ\text{C/W}) = 118^\circ\text{C}$$

$$118^\circ\text{C} < 125^\circ\text{C} = T_{J\text{MAX}} (\text{Control Section Commercial Range})$$

For the Power Transistor:

$$T_J = 75^\circ\text{C} + 24\text{W} (1^\circ\text{C/W} + 0.2^\circ\text{C/W} + 1.6^\circ\text{C/W}) = 142^\circ\text{C}$$

$$142^\circ\text{C} < 150^\circ\text{C} = T_{J\text{MAX}} (\text{Power Transistor Commercial Range})$$

In both cases the junction temperature is below the maximum rating for the respective sections, ensuring reliable operation.

TYPICAL APPLICATION

Paralleling Regulators

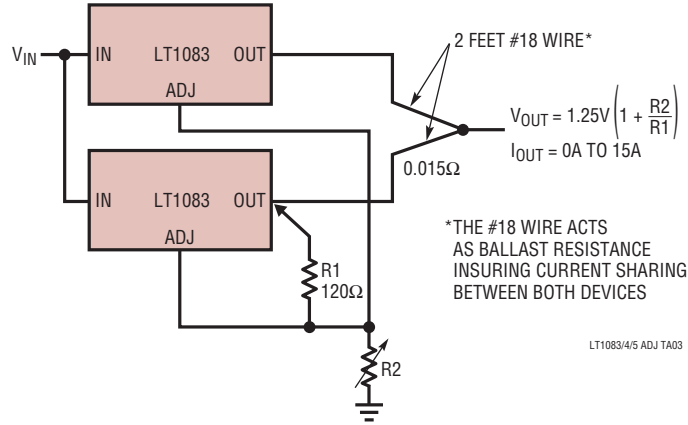

Improving Ripple Rejection

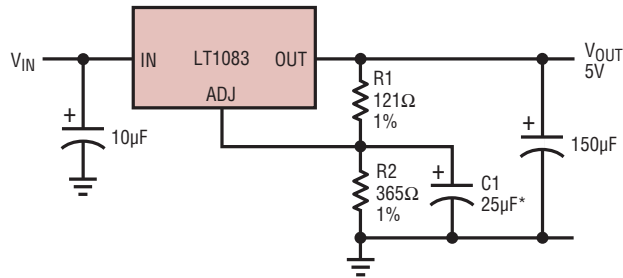

Remote Sensing

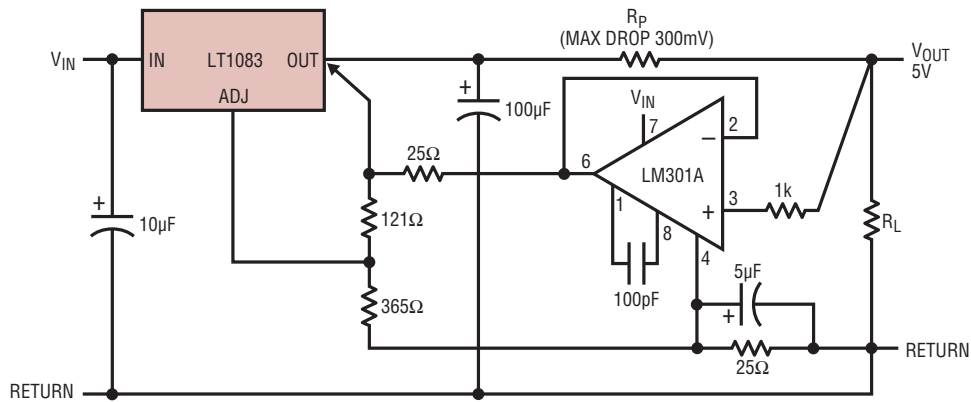

TYPICAL APPLICATION

High Efficiency Regulator with Switching Preregulator

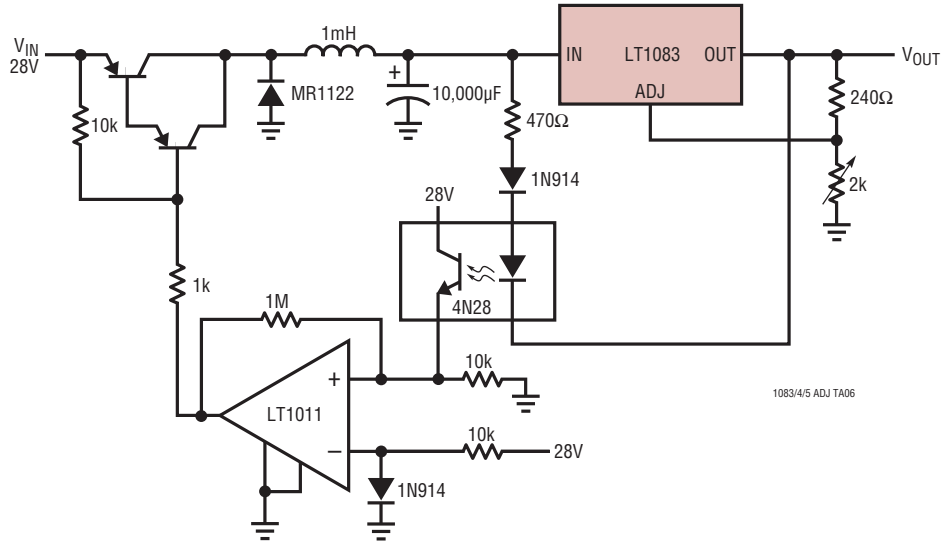

1083/4/5 ADJ TA06

1.2V to 15V Adjustable Regulator

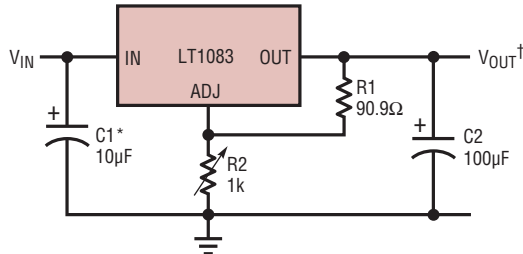

*NEEDED IF DEVICE IS FAR FROM FILTER CAPACITORS

$$V_{OUT} = 1.25V \left(1 + \frac{R2}{R1} \right)$$

1083/4/5 ADJ TA08

5V Regulator with Shutdown*

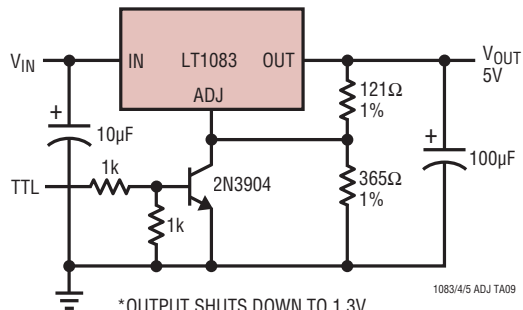

* OUTPUT SHUTS DOWN TO 1.3V

1083/4/5 ADJ TA09

PACKAGE DESCRIPTION

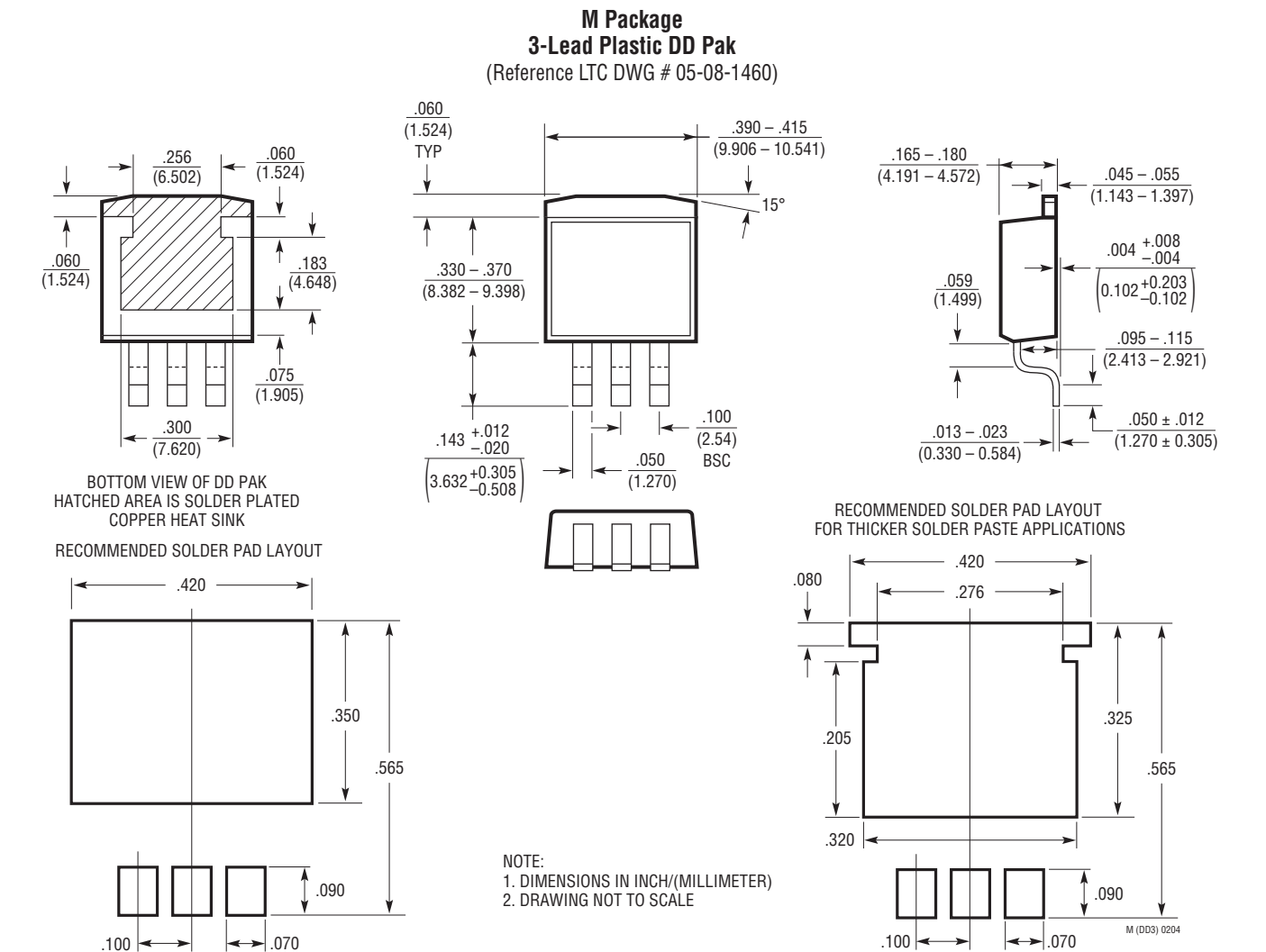
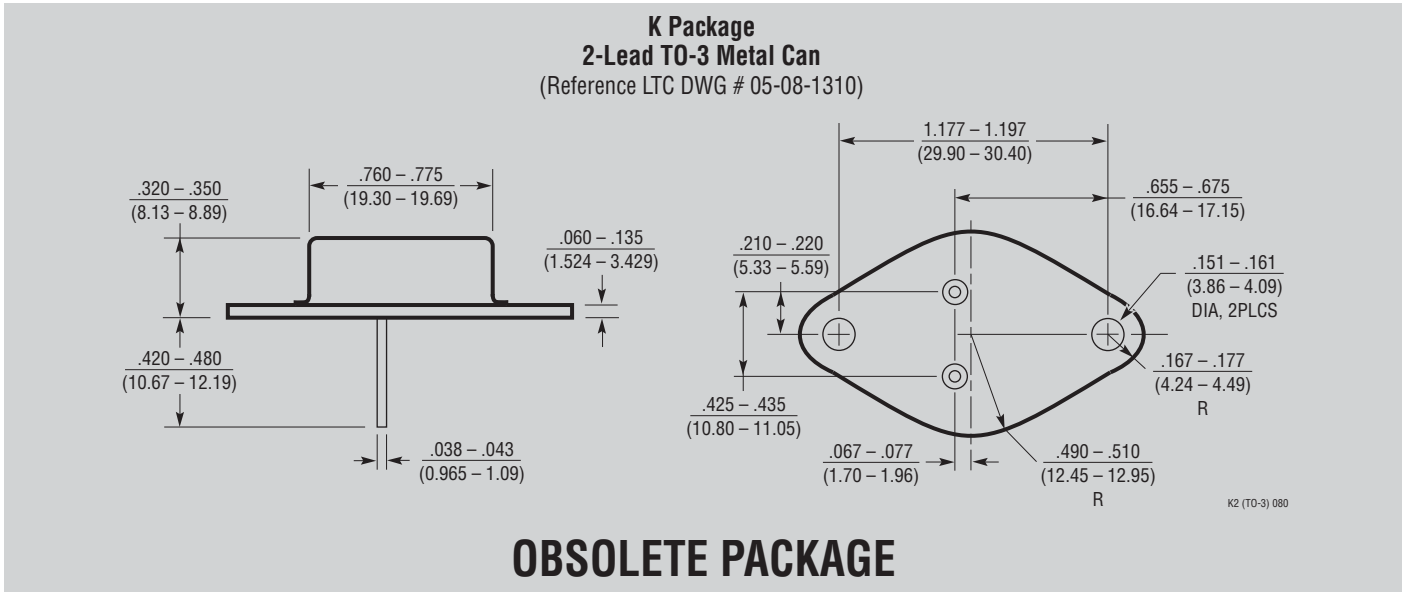

PACKAGE DESCRIPTION

P Package
3-Lead Plastic TO-3P (Similar to TO-247)
 (Reference LTC DWG # 05-08-1450)

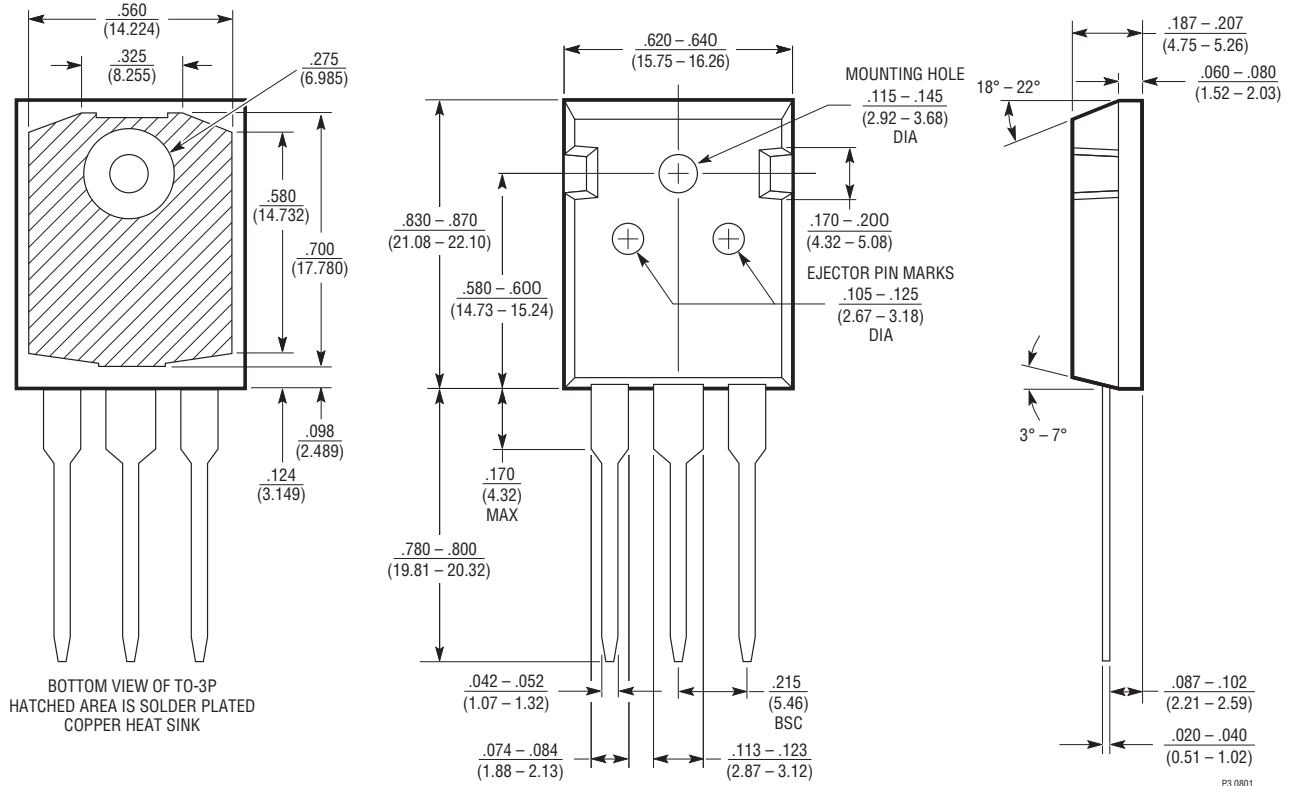

T Package
3-Lead Plastic TO-220
 (Reference LTC DWG # 05-08-1420)

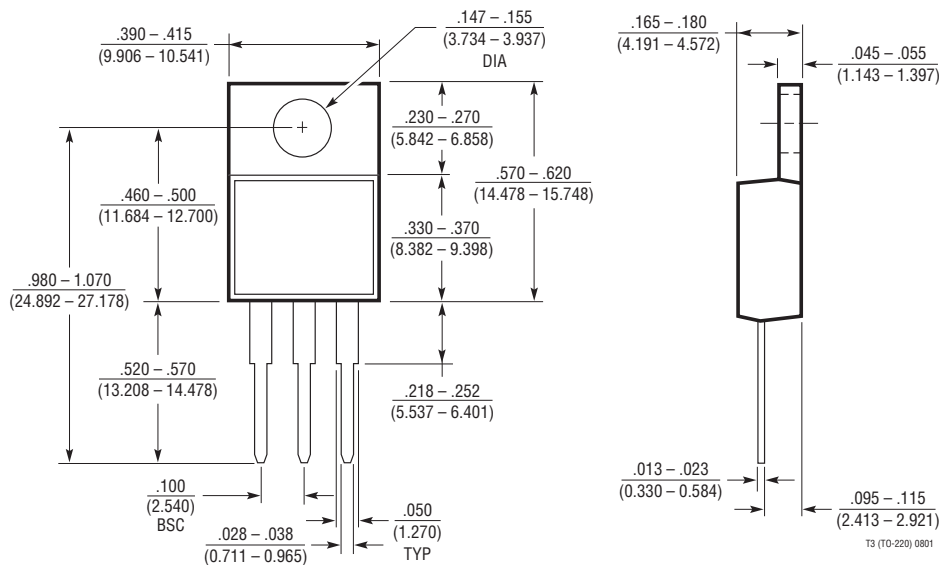

LT1083/LT1084/LT1085

TYPICAL APPLICATIONS

Automatic Light Control

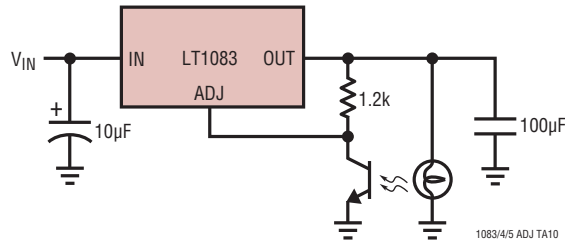

Protected High Current Lamp Driver

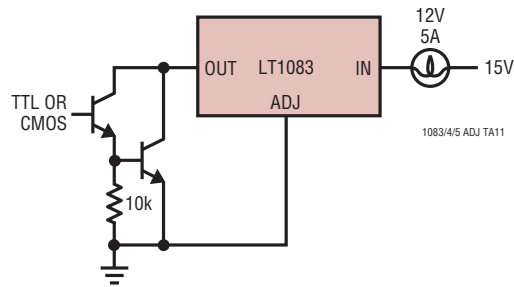

RELATED PARTS

| PART NUMBER | DESCRIPTION | COMMENTS |
|----------------------|---|--|
| LT1086 | 1.5A Low Dropout Regulator | Fixed 2.85V, 3.3V, 3.6V, 5V and 12V Output |
| LT1117 | 800mA Low Dropout Regulator | Fixed 2.85V, 3.3V, 5V or Adjustable Output |
| LT1584/LT1585/LT1587 | 7A/4.6A/3A Fast Response Low Dropout Regulators | For High Performance Microprocessors |
| LT1580 | 7A Very Low Dropout Linear Regulator | 0.54V Dropout at 7A, Fixed 2.5V _{OUT} and Adjustable |
| LT1581 | 10A Very Low Dropout Linear Regulator | 0.43V Dropout at 10A, Fixed 2.5V _{OUT} and Adjustable |
| LT1430 | High Power Step-Down Switching Regulator | 5V to 3.3V at 10A, >90% Efficiency |
| LT1575 | UltraFast™ Transient Response LDO Controller | External MOSFET Pass Element |
| LT1573 | UltraFast Transient Response LDO Controller | External PNP Pass Element |

UltraFast is a trademark of Linear Technology Corporation.