

## Ultra Low Power CODEC for Portable Audio Applications

---

### DESCRIPTION

The WM8903 is a high performance ultra-low power stereo CODEC optimised for portable audio applications.

The device features stereo ground-referenced headphone amplifiers using the Wolfson 'Class-W' amplifier techniques - incorporating an innovative dual-mode charge pump architecture - to optimise efficiency and power consumption during playback. The ground-referenced outputs eliminate headphone coupling capacitors. Both headphone and line outputs include common mode feedback paths to reject ground noise.

Control sequences for audio path setup can be pre-loaded and executed by an integrated sequencer to reduce software driver development and eliminate pops and clicks via Wolfson's SilentSwitch™ technology.

The analogue input stage can be configured for single ended or differential inputs. Up to 3 stereo microphone or line inputs may be connected. The input impedance is constant with PGA gain setting.

A stereo digital microphone interface is provided, which can also be mixed with the mic/line signals at the output mixers.

A dynamic range controller provides compression and level control to support a wide range of portable recording applications. Anti-clip and quick release features offer good performance in the presence of loud impulsive noises.

Common audio sampling frequencies are supported from a range of external clocks, either directly or generated via the Frequency Locked Loop (FLL).

The WM8903 can operate directly from a single 1.8V switched supply. For optimal power consumption, the digital core can be operated from a 1.0V supply.

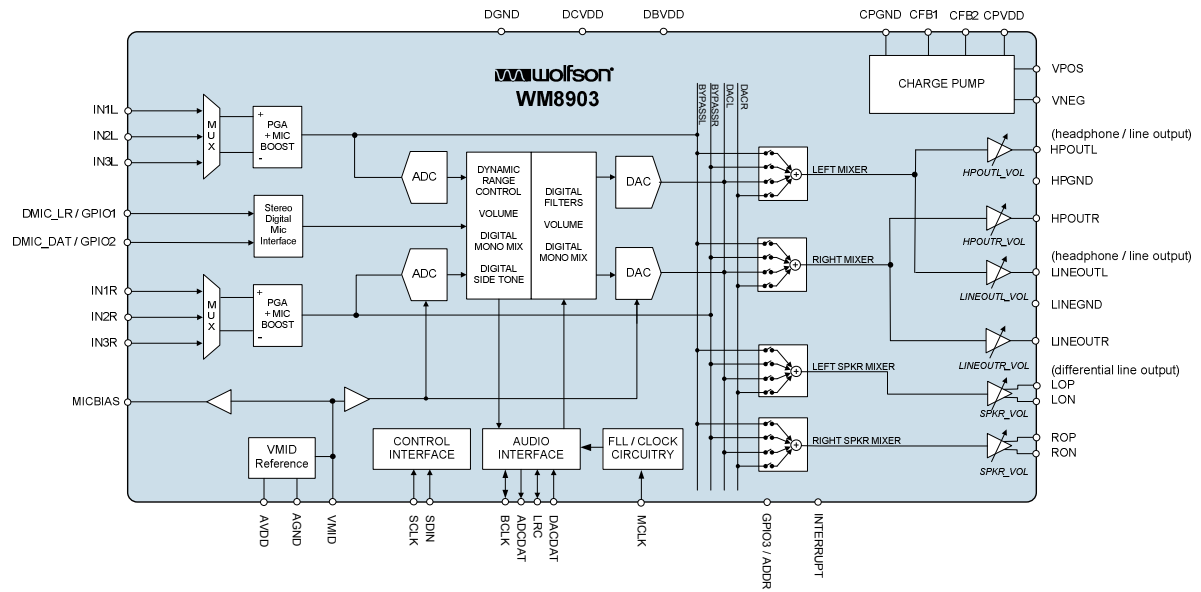
### FEATURES

- 4.5mW power consumption for DAC to headphone playback
- DAC SNR 96dB typical, THD -86dB typical
- ADC SNR 92dB typical, THD -80dB typical
- Control sequencer for pop minimised start-up and shut-down
- Single register write for default start-up sequence
- Integrated FLL provides all necessary clocks
  - Self-clocking modes allow processor to sleep
  - All standard sample rates from 8kHz to 96kHz
- Stereo digital microphone input
- 3 single ended inputs per stereo channel
- 1 fully differential mic / line input per stereo channel
- Digital Dynamic Range Controller (compressor / limiter)
- Digital sidetone mixing
- Ground-referenced headphone driver
- Ground-referenced line outputs
- Stereo differential line driver for direct interface to WM9001 speaker driver
- 40-pin QFN package (5x5mm)

### APPLICATIONS

- Portable multimedia players
- Multimedia handsets
- Handheld gaming

BLOCK DIAGRAM



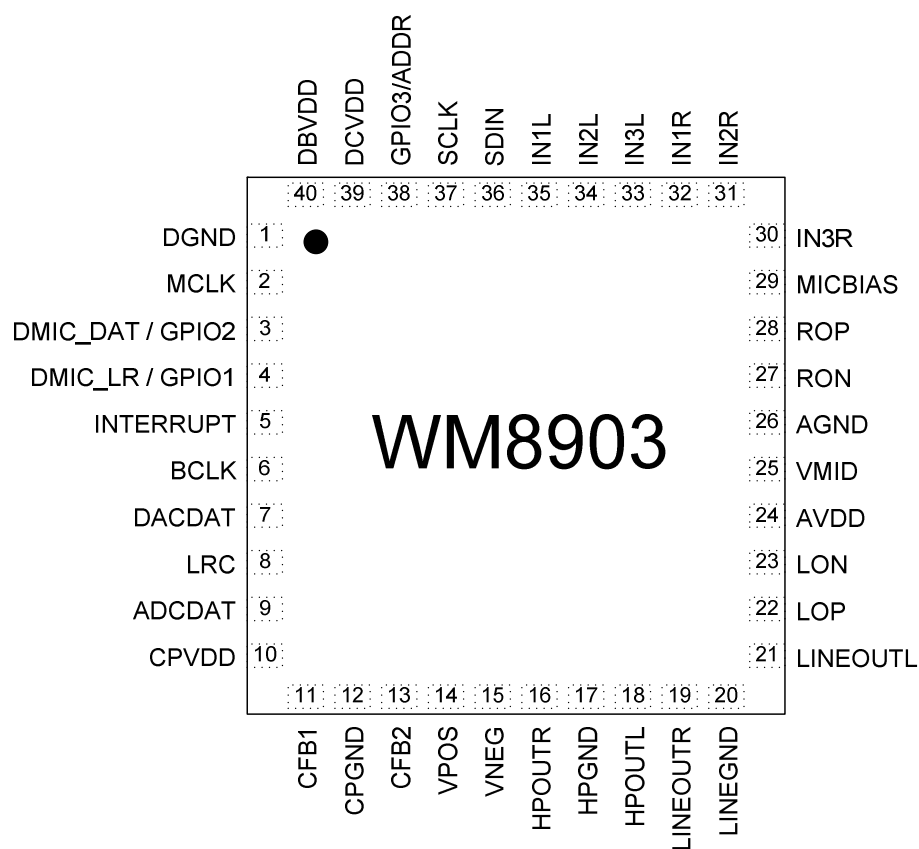
## TABLE OF CONTENTS

<b>DESCRIPTION .....</b>	<b>1</b>
<b>FEATURES.....</b>	<b>1</b>
<b>APPLICATIONS .....</b>	<b>1</b>
<b>BLOCK DIAGRAM .....</b>	<b>2</b>
<b>TABLE OF CONTENTS .....</b>	<b>3</b>
<b>PIN CONFIGURATION.....</b>	<b>6</b>
<b>ORDERING INFORMATION .....</b>	<b>6</b>
<b>PIN DESCRIPTION .....</b>	<b>7</b>
<b>ABSOLUTE MAXIMUM RATINGS.....</b>	<b>8</b>
<b>RECOMMENDED OPERATING CONDITIONS .....</b>	<b>8</b>
<b>ELECTRICAL CHARACTERISTICS .....</b>	<b>9</b>
TERMINOLOGY.....	9
COMMON TEST CONDITIONS .....	9
INPUT SIGNAL PATH.....	10
OUTPUT SIGNAL PATH.....	12
BYPASS PATH .....	14
CHARGE PUMP.....	15
FLL.....	15
OTHER PARAMETERS .....	15
<b>POWER CONSUMPTION .....</b>	<b>17</b>
COMMON TEST CONDITIONS .....	17
POWER CONSUMPTION MEASUREMENTS .....	17
<b>SIGNAL TIMING REQUIREMENTS .....</b>	<b>19</b>
COMMON TEST CONDITIONS .....	19
MASTER CLOCK.....	19
AUDIO INTERFACE TIMING .....	20
MASTER MODE .....	20
SLAVE MODE .....	21
TDM MODE .....	22
CONTROL INTERFACE TIMING .....	23
<b>DIGITAL FILTER CHARACTERISTICS .....</b>	<b>24</b>
DAC FILTER RESPONSES .....	25
ADC FILTER RESPONSES .....	26
ADC HIGH PASS FILTER RESPONSES .....	27
DE-EMPHASIS FILTER RESPONSES .....	28
<b>DEVICE DESCRIPTION .....</b>	<b>29</b>
INTRODUCTION.....	29
ANALOGUE INPUT SIGNAL PATH .....	30
INPUT PGA ENABLE .....	31
INPUT PGA CONFIGURATION.....	31
SINGLE-ENDED INPUT .....	33
DIFFERENTIAL LINE INPUT.....	33
DIFFERENTIAL MICROPHONE INPUT .....	34
INPUT PGA GAIN CONTROL .....	34
INPUT PGA COMMON MODE AMPLIFIER.....	36
ELECTRET CONDENSER MICROPHONE INTERFACE.....	37
MICBIAS CURRENT DETECT .....	37

MICBIAS CURRENT DETECT FILTERING .....	38
MICROPHONE HOOK SWITCH DETECTION .....	39
<b>DIGITAL MICROPHONE INTERFACE.....</b>	<b>40</b>
<b>ANALOGUE-TO-DIGITAL CONVERTER (ADC).....</b>	<b>42</b>
ADC DIGITAL VOLUME CONTROL .....	42
HIGH-PASS FILTER (HPF) .....	45
ADC OVERSAMPLING RATIO (OSR).....	46
<b>DYNAMIC RANGE CONTROL (DRC).....</b>	<b>46</b>
COMPRESSION/LIMITING CAPABILITIES.....	46
GAIN LIMITS .....	48
DYNAMIC CHARACTERISTICS.....	49
ANTI-CLIP CONTROL .....	50
QUICK RELEASE CONTROL.....	50
GAIN SMOOTHING .....	51
INITIALISATION .....	52
<b>DIGITAL MIXING .....</b>	<b>53</b>
DIGITAL MIXING PATHS .....	53
DAC INTERFACE VOLUME BOOST.....	54
DIGITAL SIDETONE .....	55
<b>DIGITAL-TO-ANALOGUE CONVERTER (DAC).....</b>	<b>56</b>
DAC DIGITAL VOLUME CONTROL .....	56
DAC SOFT MUTE AND SOFT UN-MUTE .....	59
DAC MONO MIX.....	60
DAC DE-EMPHASIS.....	60
DAC SLOPING STOPBAND FILTER.....	61
DAC BIAS CONTROL.....	61
DAC OVERSAMPLING RATIO (OSR).....	62
<b>OUTPUT SIGNAL PATH.....</b>	<b>63</b>
OUTPUT SIGNAL PATHS ENABLE .....	64
HEADPHONE / LINE OUTPUT SIGNAL PATHS ENABLE .....	65
OUTPUT PGA BIAS CONTROL .....	68
OUTPUT DRIVERS BIAS CONTROL.....	68
OUTPUT MIXER CONTROL.....	69
OUTPUT VOLUME CONTROL.....	71
<b>ANALOGUE OUTPUTS .....</b>	<b>75</b>
HEADPHONE OUTPUTS – HPOUTL AND HPOUTR.....	75
LINE OUTPUTS – LINEOUTL AND LINEOUTR .....	75
DIFFERENTIAL LINE OUTPUTS – LON/LOP AND RON/ROP .....	75
EXTERNAL COMPONENTS FOR GROUND-REFERENCED OUTPUTS .....	76
<b>REFERENCE VOLTAGES AND MASTER BIAS.....</b>	<b>77</b>
<b>POP SUPPRESSION CONTROL.....</b>	<b>79</b>
DISABLED INPUT / OUTPUT CONTROL.....	79
DIFFERENTIAL LINE OUTPUT DISCHARGE CONTROL.....	79
<b>CHARGE PUMP.....</b>	<b>80</b>
<b>DC SERVO .....</b>	<b>81</b>
<b>DIGITAL AUDIO INTERFACE.....</b>	<b>84</b>
MASTER AND SLAVE MODE OPERATION .....	84
OPERATION WITH TDM.....	85
BCLK FREQUENCY .....	86
AUDIO DATA FORMATS (NORMAL MODE).....	86
AUDIO DATA FORMATS (TDM MODE).....	88
<b>DIGITAL AUDIO INTERFACE CONTROL .....</b>	<b>90</b>
BCLK AND LRCLK CONTROL .....	91
COMPANDING .....	93

LOOPBACK.....	94
<b>CLOCKING AND SAMPLE RATES .....</b>	<b>95</b>
CLK_SYS CONTROL .....	97
CONTROL INTERFACE CLOCKING.....	98
AUTOMATIC CLOCKING CONFIGURATION.....	98
USB CLOCKING MODE .....	100
ADC / DAC OPERATION AT 88.2K / 96K.....	100
DIGITAL MICROPHONE (DMIC) OPERATION .....	101
<b>FREQUENCY LOCKED LOOP (FLL).....</b>	<b>101</b>
FREE-RUNNING FLL CLOCK .....	105
GPIO OUTPUTS FROM FLL .....	105
EXAMPLE FLL CALCULATION .....	105
EXAMPLE FLL SETTINGS .....	106
<b>GENERAL PURPOSE INPUT/OUTPUT (GPIO) .....</b>	<b>107</b>
<b>INTERRUPTS .....</b>	<b>112</b>
<b>CONTROL INTERFACE .....</b>	<b>115</b>
<b>CONTROL WRITE SEQUENCER.....</b>	<b>118</b>
INITIATING A SEQUENCE.....	118
PROGRAMMING A SEQUENCE.....	119
DEFAULT SEQUENCES .....	121
START-UP SEQUENCE.....	122
SHUTDOWN SEQUENCE.....	124
<b>POWER-ON RESET .....</b>	<b>126</b>
<b>QUICK START-UP AND SHUTDOWN .....</b>	<b>128</b>
QUICK START-UP (DEFAULT SEQUENCE) .....	128
QUICK SHUTDOWN (DEFAULT SEQUENCE) .....	128
<b>SOFTWARE RESET AND CHIP ID .....</b>	<b>129</b>
<b>REGISTER MAP.....</b>	<b>130</b>
REGISTER BITS BY ADDRESS .....	133
<b>APPLICATIONS INFORMATION .....</b>	<b>172</b>
RECOMMENDED EXTERNAL COMPONENTS.....	172
MIC DETECTION SEQUENCE USING MICBIAS CURRENT .....	174
<b>PACKAGE DIMENSIONS .....</b>	<b>176</b>
<b>IMPORTANT NOTICE .....</b>	<b>177</b>
ADDRESS.....	177

**PIN CONFIGURATION**



**ORDERING INFORMATION**

DEVICE	TEMPERATURE RANGE	PACKAGE	MOISTURE SENSITIVITY LEVEL	PEAK SOLDERING TEMPERATURE
WM8903LGEFK/V	-40°C to +85°C	40-lead QFN (5x5x0.55mm, lead-free)	MSL3	260°C
WM8903LGEFK/RV	-40°C to +85°C	40-lead QFN (5x5x0.55mm, lead-free, tape and reel)	MSL3	260°C

**Note:**

Tube quantity = 95  
 Reel quantity = 3,500

**PIN DESCRIPTION**

PIN	NAME	TYPE	DESCRIPTION
1	DGND	Supply	Digital ground (return path for DCVDD and DBVDD)
2	MCLK	Digital Input	Master clock for CODEC
3	GPIO2/ DMIC_DAT	Digital Input/Output	GPIO2 / Digital microphone data input
4	GPIO1/ DMIC_LR	Digital Input/Output	GPIO1 / Digital microphone clock output
5	INTERRUPT	Digital Output	Interrupt output / GPIO4
6	BCLK	Digital Input/Output	Audio interface bit clock / GPIO5
7	DACDAT	Digital Input	DAC digital audio data
8	LRC	Digital Input/Output	Audio interface left / right clock (common for ADC and DAC)
9	ADCDAT	Digital Output	ADC digital audio data
10	CPVDD	Supply	Charge pump power supply
11	CFB1	Analogue Output	Charge pump flyback capacitor pin
12	CPGND	Supply	Charge pump ground
13	CFB2	Analogue Output	Charge pump flyback capacitor pin
14	VPOS	Analogue Output	Charge pump positive supply decoupling (powers HPOUTL/R, LINEOUTL/R)
15	VNEG	Analogue Output	Charge pump negative supply decoupling (powers HPOUTL/R, LINEOUTL/R)
16	HPOUTR	Analogue Output	Right headphone output (line or headphone output)
17	HPGND	Analogue Input	Headphone ground
18	HPOUTL	Analogue Output	Left headphone output (line or headphone output)
19	LINEOUTR	Analogue Output	Right line output 1 (line output)
20	LINEGND	Analogue Input	Line-out ground
21	LINEOUTL	Analogue Output	Left line output 1 (line output)
22	LOP	Analogue Output	Left differential output positive side
23	LON	Analogue Output	Left differential output negative side
24	AVDD	Supply	Analogue power supply (powers analogue inputs, reference, ADC, DAC, LOP, LON, ROP, RON)
25	VMID	Analogue Output	Midrail voltage decoupling capacitor
26	AGND	Supply	Analogue power return
27	RON	Analogue Output	Right differential output negative side
28	ROP	Analogue Output	Right differential output positive side
29	MICBIAS	Analogue Output	Microphone bias
30	IN3R	Analogue Input	Right channel input 3
31	IN2R	Analogue Input	Right channel input 2
32	IN1R	Analogue Input	Right channel input 1
33	IN3L	Analogue Input	Left channel input 3
34	IN2L	Analogue Input	Left channel input 2
35	IN1L	Analogue Input	Left channel input 1
36	SDIN	Digital Input/Output	Control interface data Input / 2-wire acknowledge output
37	SCLK	Digital Input	Control interface clock Input
38	GPIO3 /ADDR	Digital Input/Output	GPIO3 / control interface address selection
39	DCVDD	Supply	Digital core supply
40	DBVDD	Supply	Digital buffer supply (powers audio interface and control interface)

## ABSOLUTE MAXIMUM RATINGS

Absolute Maximum Ratings are stress ratings only. Permanent damage to the device may be caused by continuously operating at or beyond these limits. Device functional operating limits and guaranteed performance specifications are given under Electrical Characteristics at the test conditions specified.



ESD Sensitive Device. This device is manufactured on a CMOS process. It is therefore generically susceptible to damage from excessive static voltages. Proper ESD precautions must be taken during handling and storage of this device.

Wolfson tests its package types according to IPC/JEDEC J-STD-020B for Moisture Sensitivity to determine acceptable storage conditions prior to surface mount assembly. These levels are:

MSL1 = unlimited floor life at <30°C / 85% Relative Humidity. Not normally stored in moisture barrier bag.

MSL2 = out of bag storage for 1 year at <30°C / 60% Relative Humidity. Supplied in moisture barrier bag.

MSL3 = out of bag storage for 168 hours at <30°C / 60% Relative Humidity. Supplied in moisture barrier bag.

The Moisture Sensitivity Level for each package type is specified in Ordering Information.

CONDITION	MIN	MAX
AVDD, DCVDD	-0.3V	+2.5V
DBVDD,	-0.3V	+4.5V
CPVDD	-0.3V	+2.2V
HPOUTL, HPOUTR, LINEOUTL, LINEOUTR	(CPVDD + 0.3V) * -1	CPVDD + 0.3
Voltage range digital inputs	DGND -0.3V	DBVDD +0.3V
Voltage range analogue inputs	AGND -0.3V	AVDD +0.3V
Temperature range, T <sub>A</sub>	-40°C	+85°C
Storage temperature after soldering	-65°C	+150°C

### Notes

1. Analogue and digital grounds must always be within 0.3V of each other.
2. All digital and analogue supplies are completely independent from each other; there is no restriction on power supply sequencing.
3. HPOUTL, HPOUTR, LINEOUTL, LINEOUTR are outputs, and should not normally become connected to DC levels. However, if the limits above are exceeded, then damage to the WM8903 may occur.

## RECOMMENDED OPERATING CONDITIONS

PARAMETER	SYMBOL	MIN	TYP	MAX	UNIT
Digital supply range (Core)	DCVDD	0.95	1.2	1.89	V
Digital supply range (Buffer)	DBVDD	1.42	1.8	3.6	V
Analogue supplies range	AVDD	1.71	1.8	2.0	V
Charge pump supply range	CPVDD	1.71	1.8	2.0	V
Ground	DGND, AGND, CPGND		0		V
Operating Temperature (ambient)	T <sub>A</sub>	-40	+25	+85	°C



## ELECTRICAL CHARACTERISTICS

### TERMINOLOGY

1. Signal-to-Noise Ratio (dB) – SNR is the difference in level between a full scale output signal and the device output noise with no signal applied, measured over a bandwidth of 20Hz to 20kHz. This ratio is also called idle channel noise. (No Auto-zero or Automute function is employed).
2. Total Harmonic Distortion (dB) – THD is the difference in level between a 1kHz full scale sinewave output signal and the first seven harmonics of the output signal. The amplitude of the fundamental frequency of the output signal is compared to the RMS value of the next seven harmonics and expressed as a ratio.
3. Total Harmonic Distortion + Noise (dB) – THD+N is the difference in level between a 1kHz full scale sine wave output signal and all noise and distortion products in the audio band. The amplitude of the fundamental reference frequency of the output signal is compared to the RMS value of all other noise and distortion products and expressed as a ratio.
4. Channel Separation (dB) – is a measure of the coupling between left and right channels. A full scale signal is applied to the left channel only, the right channel amplitude is measured. Then a full scale signal is applied to the right channel only and the left channel amplitude is measured. The worst case channel separation is quoted as a ratio.
5. Channel Level Matching (dB) – measures the difference in gain between the left and the right channels.
6. Power Supply Rejection Ratio (dB) – PSRR is a measure of ripple attenuation between the power supply pin and an output path. With the signal path idle, a small signal sine wave is summed onto the power supply rail, The amplitude of the sine wave is measured at the output port and expressed as a ratio.
7. All performance measurements carried out with 20kHz AES17 low pass filter for distortion measurements, and an A-weighted filter for noise measurement. Failure to use such a filter will result in higher THD and lower SNR and Dynamic Range readings than are found in the Electrical Characteristics. The low pass filter removes out of band noise; although it is not audible it may affect dynamic specification values.

### COMMON TEST CONDITIONS

Unless otherwise stated, the following test conditions apply throughout the following sections:

- DCVDD = 1.2V
- DBVDD = 1.8V
- AVDD = CPVDD = 1.8V
- Ambient temperature = +25°C
- Audio signal: 1kHz sine wave, sampled at 48kHz with 24-bit data resolution

Additional, specific test conditions are given within the relevant sections below.

## INPUT SIGNAL PATH

<b>Single-ended stereo line record - IN1L+IN1R pins to ADC output</b>						
Test conditions: L_MODE = R_MODE = 00b (Single ended) LIN_VOL = RIN_VOL = 00000b (-1.5dB) Total signal path gain = 4.45dB, incorporating 6dB single-ended to differential conversion gain						
PARAMETER	SYMBOL	TEST CONDITIONS	MIN	TYP	MAX	UNIT
Full Scale Input Signal Level (for ADC 0dBFS).			0.570	0.600	0.630	Vrms
			-4.88	-4.45	-4.01	dBV
			1.61	1.70	1.78	Vpk-pk
Input Resistance	R <sub>in</sub>		10	12		kΩ
Input Capacitance	C <sub>in</sub>			10		pF
DC Offset		At ADC output with ADC_HPF_ENA=0		11864		LSBs (24-bit)
				47		LSBs (16-bit)
Signal to Noise Ratio	SNR	A-weighted	85	91		dBFS
Total Harmonic Distortion	THD	-5.45dBV input		-78	-68	dBFS
Total Harmonic Distortion + Noise	THD+N	-5.45dBV input		-76	-66	dBFS
Channel Separation		1kHz signal, -5.45dBV		85		dB
		10kHz signal, -5.45dBV		80		
Channel Level Matching		1kHz signal, -5.45dBV		+/-1		dB
Power Supply Rejection Ratio	PSRR	1kHz, 100mVpk-pk		60		dB
		20kHz, 100mV pk-pk		40		

<b>Differential stereo line record - IN2L+IN3L / IN2R+IN3R pins to ADC output</b>						
Test conditions: L_MODE = R_MODE = 01b (Differential Line) LIN_VOL = RIN_VOL = 01111b (+4.2dB) Total signal path gain = +4.20dB						
PARAMETER	SYMBOL	TEST CONDITIONS	MIN	TYP	MAX	UNIT
Line Input Full Scale Signal Level applied to IN2L or IN2R (for ADC 0dBFS output)			0.586	0.617	0.648	Vrms
			-4.64	-4.20	-3.77	dBV
			1.657	1.745	1.833	Vpk-pk
IN3L, IN3R input range				+/-100		mV
Input Resistance	R <sub>in</sub>		10	12		kΩ
Input Capacitance	C <sub>in</sub>			10		pF
DC Offset		At ADC output with ADC_HPF_ENA=0		11864		LSBs (24-bit)
				47		LSBs (16-bit)
Signal to Noise Ratio	SNR	A-weighted	85	92		dBFS
Total Harmonic Distortion	THD	-5.2dBV input		-80	-66	dBFS
Total Harmonic Distortion + Noise	THD+N	-5.2dBV input		-78	-64	dBFS
Common Mode Rejection Ratio	CMRR	1kHz, 100mV pk-pk		60		dB
Channel Separation		1kHz signal, -5.2dBV		85		dB
		10kHz signal, -5.2dBV		80		
Channel Level Matching		1kHz signal, -5.2dBV		+/-1		dB
Power Supply Rejection Ratio	PSRR	1kHz, 100mVpk-pk		60		dB
		20kHz, 100mV pk-pk		40		

Single-ended stereo record from analogue microphones - IN2L / IN2R pins to ADC output						
Test conditions: L_MODE = R_MODE = 00b (Single ended) LIN_VOL = RIN_VOL = 11111b (+28.3dB) Total signal path gain = +34.3dB, incorporating 6dB single-ended to differential conversion gain						
PARAMETER	SYMBOL	TEST CONDITIONS	MIN	TYP	MAX	UNIT
Single-ended mic input full-scale Signal Level (for ADC 0dBFS output)				0.019 -34.3 0.055		Vrms dBV Vpk-pk
Input Resistance	R <sub>in</sub>		10	12		kΩ
Input Capacitance	C <sub>in</sub>			10		pF
DC offset		At ADC output with ADC_HP_F_ENA=0		11864 47		LSBs (24-bit) LSBs (16-bit)
Signal to Noise Ratio	SNR	A-weighted		73		dBFS
Total Harmonic Distortion	THD	-35dBV input		-78		dBFS
Total Harmonic Distortion + Noise	THD+N	-35dBV input		-77		dBFS
Channel Level Matching		1kHz signal, -35dBV		+/-3		dB
Power Supply Rejection Ratio	PSRR	1kHz, 100mVpk-pk		60		dB
		20kHz, 100mV pk-pk		40		

Differential stereo record from analogue microphones - IN1L+IN2L / IN1R+IN2R pins to ADC output						
Test conditions: L_MODE = R_MODE = 10b (Differential mic) LIN_VOL = RIN_VOL = 00111b (+30dB) Total signal path gain = +30dB						
PARAMETER	SYMBOL	TEST CONDITIONS	MIN	TYP	MAX	UNIT
Differential Mic Input Full Scale Signal Level IN1L-IN2L / IN1R-IN2R (for ADC 0dBFS output)				0.032 -30 0.089		Vrms dBV Vpk-pk
Input Resistance	R <sub>in</sub>		100	120		kΩ
Input Capacitance	C <sub>in</sub>			10		pF
DC Offset		At ADC output with ADC_HP_F_ENA=0		189813 742		LSBs (24-bit) LSBs (16-bit)
Signal to Noise Ratio	SNR	A-weighted		75		dBFS
Total Harmonic Distortion	THD	-31dBV input		-78		dBFS
Total Harmonic Distortion + Noise	THD+N	-31dBV input		-72		dBFS
Common Mode Rejection Ratio	CMRR	1kHz, 100mVpk-pk		60		dB
Channel Separation		1kHz signal, -31dBV		85		dB
		10kHz signal, -31dBV		80		
Channel Level Matching		1kHz signal, -31dBV		+/-1		dB
PSRR (Referred to Input)	PSRR	1kHz, 100mVpk-pk		60		dB
		20kHz, 100mV pk-pk		40		

PGA and microphone boost					
PARAMETER	TEST CONDITIONS	MIN	TYP	MAX	UNIT
Minimum PGA gain setting	L_MODE/R_MODE= 00b or 01b		-1.55		dB
	L_MODE/R_MODE= 10b		+12		
Maximum PGA gain setting	L_MODE/R_MODE= 00b or 01b		+28.28		dB
	L_MODE/R_MODE= 10b		+30		
Single-ended to differential conversion gain	L_MODE/R_MODE= 00b		+6		dB
PGA gain accuracy	L_MODE/R_MODE= 00b Gain -1.5 to +6.7dB	-1		+1	dB
	L_MODE/R_MODE= 00b Gain +7.5 to +28.3dB	-1.5		+1.5	
	L_MODE/R_MODE= 1X Gain +12 to +24dB	-1		+1	
	L_MODE/R_MODE= 1X Gain +27 to +30dB	-1.5		+1.5	
Mute attenuation	all modes of operation		88		dB
Equivalent input noise	L_MODE/R_MODE= 00b or 01b		114		$\mu$ Vrms
			828		nV/ $\sqrt$ Hz

## OUTPUT SIGNAL PATH

Stereo Playback to Headphones - DAC input to HPOUTL+HPOUTR pins with 15 $\Omega$ load						
Test conditions: HPOUTL_VOL = HPOUTR_VOL = 111001b (0dB)						
PARAMETER	SYMBOL	TEST CONDITIONS	MIN	TYP	MAX	UNIT
Output Power (per Channel)	P <sub>o</sub>	1% THD R <sub>Load</sub> = 30 $\Omega$		28 0.91 -0.76		mW Vrms dBV
		1% THD R <sub>Load</sub> = 15 $\Omega$		30 0.67 -3.47		mW Vrms dBV
DC Offset		DC servo enabled, calibration complete.	0		+/-1.5	mV
Signal to Noise Ratio	SNR	A-weighted	90	96		dB
Total Harmonic Distortion	THD	R <sub>L</sub> =30 $\Omega$ ; P <sub>o</sub> =2mW		-93		dB
		R <sub>L</sub> =30 $\Omega$ ; P <sub>o</sub> =20mW		-82		
		R <sub>L</sub> =15 $\Omega$ ; P <sub>o</sub> =2mW		-83	-72	
		R <sub>L</sub> =15 $\Omega$ ; P <sub>o</sub> =20mW		-83		
Total Harmonic Distortion + Noise	THD+N	R <sub>L</sub> =30 $\Omega$ ; P <sub>o</sub> =2mW		-90		dB
		R <sub>L</sub> =30 $\Omega$ ; P <sub>o</sub> =20mW		-82		
		R <sub>L</sub> =15 $\Omega$ ; P <sub>o</sub> =2mW		-81	-70	
		R <sub>L</sub> =15 $\Omega$ ; P <sub>o</sub> =20mW		-81		
Channel Separation		1kHz signal, 0dBFS		100		dB
		10kHz signal, 0dBFS		85		
Channel Level Matching		1kHz signal, 0dBFS		+/-1		dB
Power Supply Rejection Ratio	PSRR	1kHz, 100mV pk-pk		60		dB
		20kHz, 100mV pk-pk		40		

Stereo Playback to Line-out - DAC input to LINEOUTL+LINEOUTR pins with 3.01kΩ / 50pF load						
Test conditions: LINEOUTL_VOL = LINEOUTR_VOL = 111001b (0dB)						
PARAMETER	SYMBOL	TEST CONDITIONS	MIN	TYP	MAX	UNIT
Full Scale Output Signal Level		DAC 0dBFS output at 0dB volume	0.95	1.0	1.05	Vrms
			-0.446	0	0.424	dBV
			2.69	2.83	2.97	Vpk-pk
DC offset		DC servo enabled. Calibration complete.	0		+/-1.5	mV
Signal to Noise Ratio	SNR	A-weighted	90	95		dB
Total Harmonic Distortion	THD	3.01kΩ load		-86	-77	dB
Total Harmonic Distortion + Noise	THD+N	3.01kΩ load		-84	-75	dB
Channel Separation		1kHz signal, 0dBFS		100		dB
		10kHz signal, 0dBFS		85		
Channel Level Matching		1kHz signal, 0dBFS		+/-1dB		dB
Power Supply Rejection Ratio	PSRR	1kHz, 100mVpk-pk		60		dB
		20kHz, 100mV pk-pk		40		

Stereo Playback to Differential Line-out - DAC input to LOP+LON or ROP+RON pins with 10kΩ / 50pF load						
Test conditions: SPKR_LVOL = SPKR_RVOL = 111001b (0dB)						
PARAMETER	SYMBOL	TEST CONDITIONS	MIN	TYP	MAX	UNIT
Full Scale Output Signal Level		0dBFS Measured Differentially	0.95	1.0	1.05	Vrms
			-0.446	0	0.424	dBV
			2.69	2.83	2.97	Vpk-pk
Common mode output level				AVDD/2		
Common mode output error				+/-7		mV
Signal to Noise Ratio	SNR	A-weighted	90	95		dB
Total Harmonic Distortion	THD			-92	-82	dB
Total Harmonic Distortion + Noise	THD+N			-88	-80	dB
Channel Separation		1kHz signal, 0dBFS		100		dB
		10kHz signal, 0dBFS		85		
Channel Level Matching		1kHz signal		+/-1dB		dB
Power Supply Rejection Ratio	PSRR	1kHz, 100mVpk-pk		60		dB
		20kHz, 100mV pk-pk		40		

Output PGAs (HP, LINE and Differential LINE)					
PARAMETER	TEST CONDITIONS	MIN	TYP	MAX	UNIT
Minimum PGA gain setting			-57		dB
Maximum PGA gain setting			6		dB
PGA Gain Step Size			1		dB
PGA gain accuracy	+6dB to 0dB	-1.5		+1.5	dB
PGA gain accuracy	0dB to -57dB	-1		+1	dB
Mute attenuation	HPOUTL/R		77		dB
	LINEOUTL/R		79		
	Differential LINE (LOP-LOR/ROP-RON)		105		dB

**BYPASS PATH**

<b>Differential stereo line input to stereo line output- IN2L-IN3L / IN2R-IN3R pins to LINEOUTL+LINEOUTR pins with 3.01k<math>\Omega</math> / 50pF load</b>						
Test conditions: L_MODE = R_MODE = 01b (Differential Line) LIN_VOL = RIN_VOL = 00101b (0dB) LINEOUTL_VOL = LINEOUTR_VOL = 111001b (0dB) Total signal path gain = 0dB						
PARAMETER	SYMBOL	TEST CONDITIONS	MIN	TYP	MAX	UNIT
Maximum Line Input Signal Level applied to IN2L or IN2R				1.0 0 2.83		Vrms dBV Vpk-pk
Full Scale Output Signal Level			0.95 -0.446 2.69	1.0 0 2.83	1.05 0.424 2.97	Vrms dBV Vpk-pk
Signal to Noise Ratio	SNR	A-weighted	85	97		dBV
Total Harmonic Distortion	THD	-1.0dBV input		-92	-82	dBV
Total Harmonic Distortion + Noise	THD+N	-1.0dBV input		-89	-80	dBV
Channel Separation		1kHz signal, -1dBV		85		dB
		10kHz signal, -1dBV		80		
Channel Level Matching		1kHz signal, -1dBV		+/-1		dB
Power Supply Rejection Ratio	PSRR	1kHz, 100mVpk-pk		56		dB
		20kHz, 100mV pk-pk		40		

**CHARGE PUMP**

PARAMETER	SYMBOL	TEST CONDITIONS	MIN	TYP	MAX	UNIT
Charge pump start-up time				40		µs
<b>External component requirements</b>						
To achieve specified headphone output power and performance						
Flyback capacitor (between CFB1 and CFB2 pins)	C <sub>FB</sub>	at 2V	1			µF
VPOS capacitor		at 2V	2			µF
VNEG capacitor		at 2V	2			µF

**FLL**

PARAMETER	SYMBOL	TEST CONDITIONS	MIN	TYP	MAX	UNIT
Input Frequency	F <sub>REF</sub>	FLL_CLK_REF_DIV = 00	0.032		13.5	MHz
		FLL_CLK_REF_DIV = 01	0.032		27	MHz
Lock time				2		ms
Free-running mode start-up time		VMID enabled		100		µs
Free-running mode frequency accuracy		Reference supplied initially		+/-10		%
		No reference provided		+/-30		%

**OTHER PARAMETERS**

<b>VMID Reference</b>						
PARAMETER	TEST CONDITIONS	MIN	TYP	MAX	UNIT	
Midrail Reference Voltage (VMID pin)		-3%	AVDD/2	+3%	V	

<b>Microphone bias</b> (for analogue electret condenser microphones)						
Additional test conditions: MICBIAS_ENA=1, all parameters measured at the MICBIAS pin						
PARAMETER	SYMBOL	TEST CONDITIONS	MIN	TYP	MAX	UNIT
Bias Voltage	V <sub>MICBIAS</sub>	3mA load current	-5%	0.9×AVDD	+5%	V
Maximum source current	I <sub>MICBIAS</sub>			4		mA
Noise spectral density		At 1kHz		19		nV/√Hz
Power Supply Rejection Ratio	PSRR	1kHz, 100mV pk-pk		50		dB
		20kHz, 100mV pk-pk		70		
<b>MICBIAS Current Detect Function</b> (See Notes 1, 2)						
Current Detect Threshold (Microphone insertion)		MICDET_THR = 00			100	µA
Current Detect Threshold (Microphone removal)			15			
Delay Time for Current Detect Interrupt	t <sub>DET</sub>			1.25-15		ms
<b>MICBIAS Short Circuit (Hook Switch) Detect Function</b> (See Notes 1, 2)						
Short Circuit Detect Threshold (Button press)		MICSHORT_THR = 00	400	520	647	µA
Short Circuit Detect Hysteresis (See Note 3)				50		
Minimum Delay Time for Short Circuit Detect Interrupt	t <sub>SHORT</sub>			40		ms
Short Circuit Detect measurement frequency				250		Hz

**Notes:**

1. If AVDD ≠ 1.8, current threshold values should be multiplied by (AVDD/1.8)

2. MICBIAS current detect and short circuit (Hook switch) detect functionality tested using GPIO pin rather than by interrupt.
3. Hysteresis = difference between Button Press and Button Release thresholds

Digital Inputs / Outputs						
PARAMETER	SYMBOL	TEST CONDITIONS	MIN	TYP	MAX	UNIT
Input HIGH Level	$V_{IH}$		$0.7 \times DBVDD$			V
Input LOW Level	$V_{IL}$				$0.3 \times DBVDD$	V
Output HIGH Level	$V_{OH}$	$I_{OH} = +1mA$	$0.9 \times DBVDD$			V
Output LOW Level	$V_{OL}$	$I_{OL} = -1mA$			$0.1 \times DBVDD$	V



## POWER CONSUMPTION

The WM8903 power consumption is dependent on many parameters. Most significantly, it depends on supply voltages, sample rates, mode of operation, and output loading.

The power consumption on each supply rail varies approximately with the square of the voltage. Power consumption is greater at fast sample rates than at slower ones. When the digital audio interface is operating in Master mode, the DBVDD current is significantly greater than in Slave mode. (Note also that power savings can be made by using MCLK as the BCLK source in Slave mode.) The output load conditions (impedance, capacitance and inductance) can also impact significantly on the device power consumption.

## COMMON TEST CONDITIONS

Unless otherwise stated, the following test conditions apply throughout the following sections:

- Ambient temperature = +25°C
- Audio signal = quiescent (zero amplitude)
- Sample rate = 44.1kHz
- MCLK = 12MHz
- Audio interface mode = Master (LRCLK\_DIR=1, BCLK\_DIR=1)
- CLK\_SRC\_SEL = 0 (System clock comes direct from MCLK, not from FLL)

Additional, variant test conditions are quoted within the relevant sections below. Where applicable, power dissipated in the headphone or line loads is included.

## POWER CONSUMPTION MEASUREMENTS

**Single-ended stereo line record** - IN1L/R, IN2L/R or IN3L/R pins to ADC output.

Test conditions:

L\_MODE = R\_MODE = 00b (Single ended)

LIN\_VOL = RIN\_VOL = 00000b (-1.5dB)

ADC\_OSR128 = 0

Variant test conditions	AVDD		DCVDD		DBVDD		CPVDD		TOTAL
	V	mA	V	mA	V	mA	V	mA	mW
44.1kHz sample rate	1.8	3.60	1.2	1.04	1.8	0.10	1.8	0.00	7.9
8kHz sample rate	1.8	3.40	1.2	0.50	1.8	0.03	1.8	0.00	6.8

**Differential stereo record from analogue microphones** - IN1L/R, IN2L/R or IN3L/R pins to ADC out.

Test conditions:

L\_MODE = R\_MODE = 10b (Differential mic)

ADC\_OSR128 = 0

Variant test conditions	AVDD		DCVDD		DBVDD		CPVDD		TOTAL
	V	mA	V	mA	V	mA	V	mA	mW
44.1kHz sample rate	1.8	3.60	1.2	1.00	1.8	0.10	1.8	0.00	7.9
8kHz sample rate	1.8	3.40	1.2	0.50	1.8	0.03	1.8	0.00	6.8

**Stereo Playback to Headphones** - DAC input to HPOUTL+HPOUTR pins with 30Ω load.

Test conditions

DACBIAS\_SEL = 01b (Normal bias x 0.5)

DACVMID\_BIAS\_SEL = 11b (Normal bias x 0.75)

PGA\_BIAS = 011b (Normal bias x 0.5)

CP\_DYN\_PWR = 1b (Charge pump controlled by real-time audio level)

Variant test conditions	AVDD		DCVDD		DBVDD		CPVDD		TOTAL
	V	mA	V	mA	V	mA	V	mA	mW
Slave mode, 44.1kHz sample rate, quiescent	1.8	1.60	1.2	0.76	1.8	0.00	1.8	0.41	4.5
Master mode, 44.1kHz sample rate, quiescent	1.8	1.60	1.2	0.76	1.8	0.09	1.8	0.41	4.7
Master mode, 44.1kHz, P <sub>o</sub> = 0.1mW/channel	1.8	1.60	1.2	0.90	1.8	0.09	1.8	1.85	7.5
Master mode, 44.1kHz, P <sub>o</sub> = 1mW/channel	1.8	1.60	1.2	0.92	1.8	0.09	1.8	5.77	14.5
Master mode, 8kHz sample rate, quiescent	1.8	1.60	1.2	0.65	1.8	0.03	1.8	0.41	4.4
Master mode, 8kHz, P <sub>o</sub> = 0.1mW/channel	1.8	1.60	1.2	0.71	1.8	0.03	1.8	1.85	7.1

**Stereo Playback to Line-out** - DAC input to LINEOUTL+LINEOUTR or HPOUTL+HPOUTR pins with 3.01kΩ / 50pF load

Test conditions:

CP\_DYN\_PWR = 1b (Charge pump controlled by real-time audio level)

Variant test conditions	AVDD		DCVDD		DBVDD		CPVDD		TOTAL
	V	mA	V	mA	V	mA	V	mA	mW
44.1kHz sample rate	1.8	1.95	1.2	0.76	1.8	0.09	1.8	0.32	5.2
8kHz sample rate	1.8	1.95	1.2	0.68	1.8	0.03	1.8	0.32	4.9

**Stereo analogue bypass to headphones** - IN1L/R, IN2L/R or IN3L/R pins to HPOUTL+HPOUTR pins with 30Ω load.

Test conditions: Audio interface disabled

Note that the Analogue bypass configuration does not benefit from the Class W dynamic control, and the power consumption is greater in this case than the DAC to Line-Out case. See "Charge Pump" section.

Variant test conditions	AVDD		DCVDD		DBVDD		CPVDD		TOTAL
	V	mA	V	mA	V	mA	V	mA	mW
Quiescent	1.8	1.46	1.2	0.12	1.8	0.00	1.8	1.54	5.5
P <sub>o</sub> = 0.1mW/channel	1.8	1.46	1.2	0.12	1.8	0.00	1.8	4.54	11.0

**Off**

Test conditions: No Clocks applied

Variant test conditions	AVDD		DCVDD		DBVDD		CPVDD		TOTAL
	V	mA	V	mA	V	mA	V	mA	mW
None	1.8	0.01	1.2	0.012	1.8	0.003	1.8	0.005	0.047

## SIGNAL TIMING REQUIREMENTS

### COMMON TEST CONDITIONS

Unless otherwise stated, the following test conditions apply throughout the following sections:

- Ambient temperature = +25°C
- DCVDD = 1.2V
- DBVDD = AVDD = CPVDD = 1.8V
- DGND = AGND = CPGND = 0V

Additional, specific test conditions are given within the relevant sections below.

### MASTER CLOCK

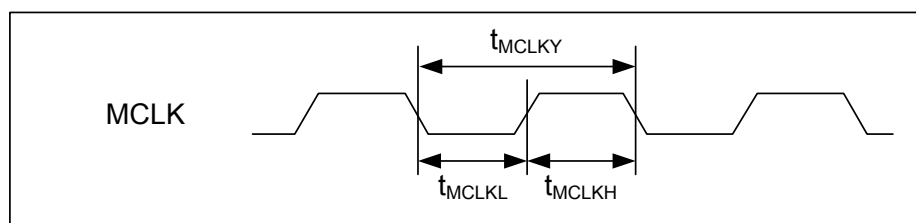
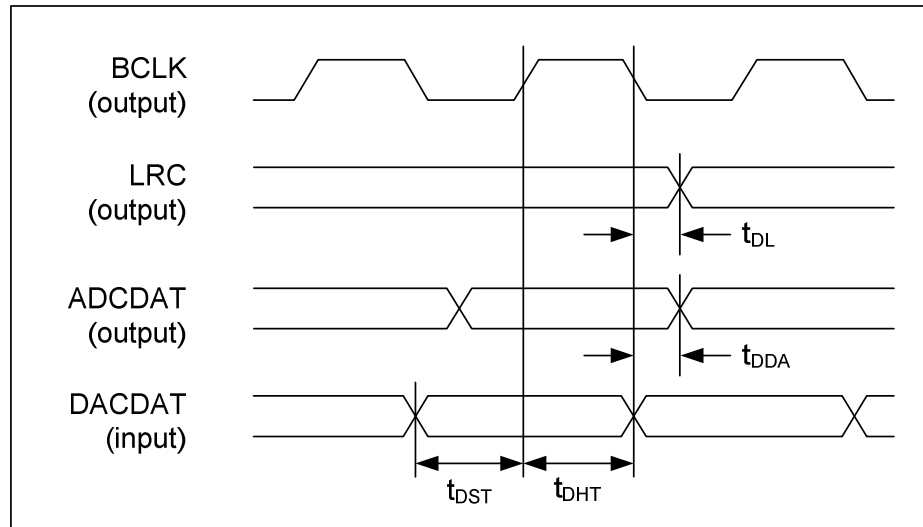


Figure 1 Master Clock Timing

Master Clock Timing						
PARAMETER	SYMBOL	TEST CONDITIONS	MIN	TYP	MAX	UNIT
MCLK cycle time	$T_{MCLKY}$	MCLKDIV2=1	40			ns
		MCLKDIV2=0	80			ns
MCLK cycle time	$T_{MCLKY}$	DCVDD ≥ 1.62V MCLKDIV2=0	54.25			ns
MCLK duty cycle	$T_{MCLKDS}$		60:40		40:60	

**AUDIO INTERFACE TIMING**

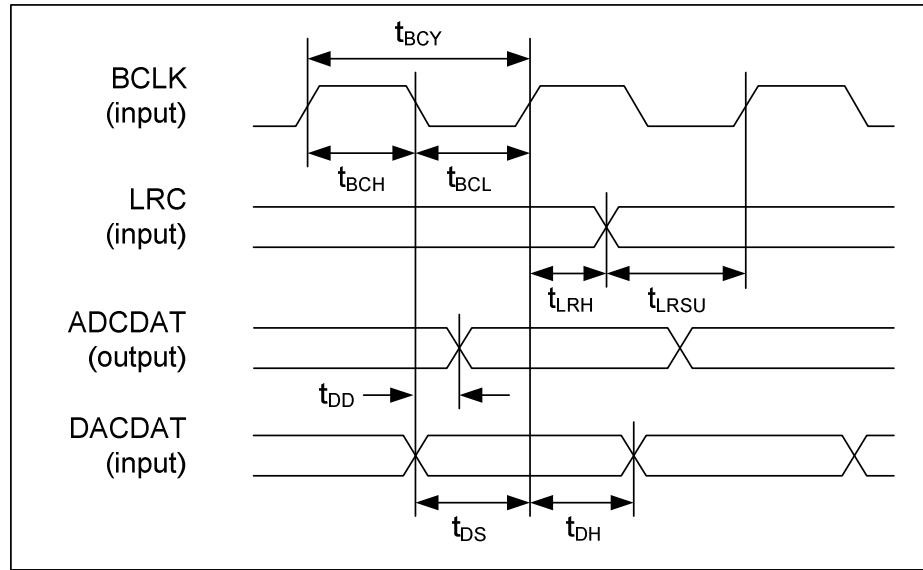
**MASTER MODE**



**Figure 2 Audio Interface Timing – Master Mode**

Audio Interface Timing – Master Mode					
PARAMETER	SYMBOL	MIN	TYP	MAX	UNIT
LRC propagation delay from BCLK falling edge	$t_{DL}$			10	ns
ADCDAT propagation delay from BCLK falling edge	$t_{DDA}$			10	ns
DACDAT setup time to BCLK rising edge	$t_{DST}$	10			ns
DACDAT hold time from BCLK rising edge	$t_{DHT}$	10			ns

**SLAVE MODE**



**Figure 3 Audio Interface Timing – Slave Mode**

Audio Interface Timing – Slave Mode					
PARAMETER	SYMBOL	MIN	TYP	MAX	UNIT
BCLK cycle time	$t_{BCY}$	50			ns
BCLK pulse width high	$t_{BCH}$	20			ns
BCLK pulse width low	$t_{BCL}$	20			ns
LRC set-up time to BCLK rising edge	$t_{LRSU}$	10			ns
LRC hold time from BCLK rising edge	$t_{LRH}$	10			ns
DACDAT hold time from BCLK rising edge	$t_{DH}$	10			ns
ADCDAT propagation delay from BCLK falling edge	$t_{DD}$			10	ns
DACDAT set-up time to BCLK rising edge	$t_{DS}$			40	ns

**Note:** BCLK period must always be greater than or equal to MCLK period.

**TDM MODE**

In TDM mode, it is important that two devices do not attempt to drive the ADCDAT pin simultaneously. The timing of the WM8903 ADCDAT pin tri-stating at the start and end of the data transmission is described below.

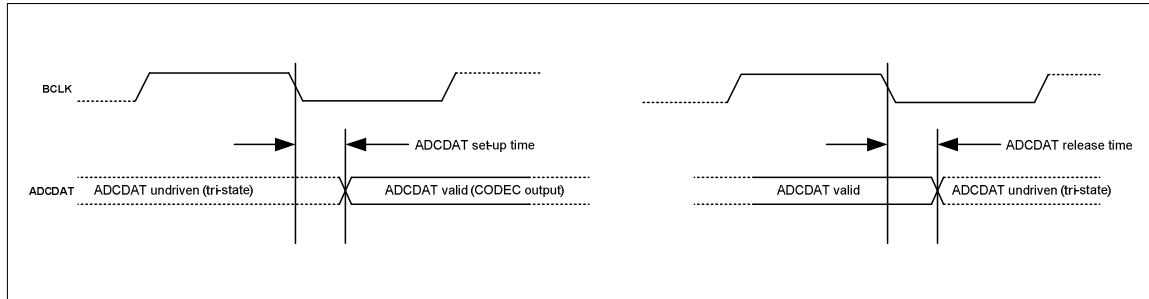
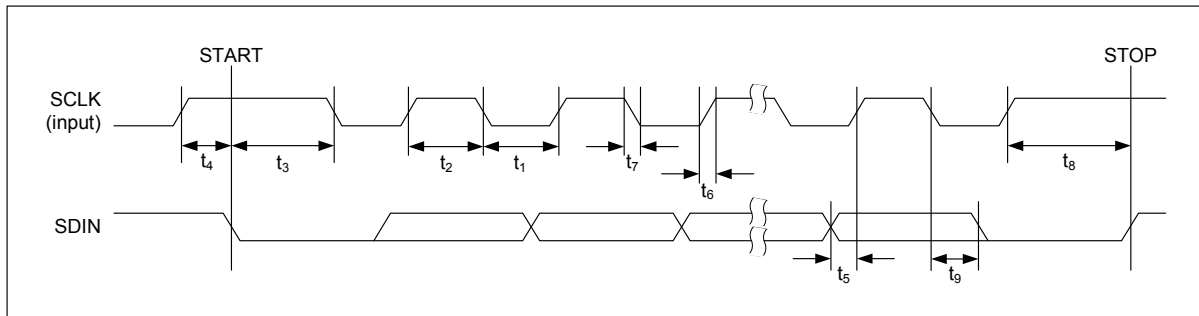


Figure 4 Audio Interface Timing – TDM Mode

Audio Interface Timing – TDM Mode					
PARAMETER	SYMBOL	MIN	TYP	MAX	UNIT
ADCDAT setup time from BCLK falling edge			4		ns
ADCDAT release time from BCLK falling edge			25		ns

**CONTROL INTERFACE TIMING****Figure 5 Control Interface Timing**

Control Interface Timing					
PARAMETER	SYMBOL	MIN	TYP	MAX	UNIT
SCLK Frequency				526	kHz
SCLK Low Pulse-Width	$t_1$	1.3			$\mu$ s
SCLK High Pulse-Width	$t_2$	600			ns
Hold Time (Start Condition)	$t_3$	600			ns
Setup Time (Start Condition)	$t_4$	600			ns
Data Setup Time	$t_5$	100			ns
SDIN, SCLK Rise Time	$t_6$			300	ns
SDIN, SCLK Fall Time	$t_7$			300	ns
Setup Time (Stop Condition)	$t_8$	600			ns
Data Hold Time	$t_9$			900	ns
Pulse width of spikes that will be suppressed	$t_{ps}$	0		5	ns

## DIGITAL FILTER CHARACTERISTICS

PARAMETER	TEST CONDITIONS	MIN	TYP	MAX	UNIT
<b>ADC Filter</b>					
Passband	+/- 0.05dB	0		0.454 fs	
	-6dB		0.5fs		
Passband Ripple				+/- 0.05	dB
Stopband		0.546s			
Stopband Attenuation	f > 0.546 fs	-60			dB
<b>DAC Normal Filter</b>					
Passband	+/- 0.05dB	0		0.454 fs	
	-6dB		0.5 fs		
Passband Ripple	0.454 fs			+/- 0.03	dB
Stopband		0.546 fs			
Stopband Attenuation	F > 0.546 fs	-50			dB
<b>DAC Sloping Stopband Filter</b>					
Passband	+/- 0.03dB	0		0.25 fs	
	+/- 1dB	0.25 fs		0.454 fs	
	-6dB		0.5 fs		
Passband Ripple	0.25 fs			+/- 0.03	dB
Stopband 1		0.546 fs		0.7 fs	
Stopband 1 Attenuation	f > 0.546 fs	-60			dB
Stopband 2		0.7 fs		1.4 fs	
Stopband 2 Attenuation	f > 0.7 fs	-85			dB
Stopband 3		1.4 fs			
Stopband 3 Attenuation	F > 1.4 fs	-55			dB

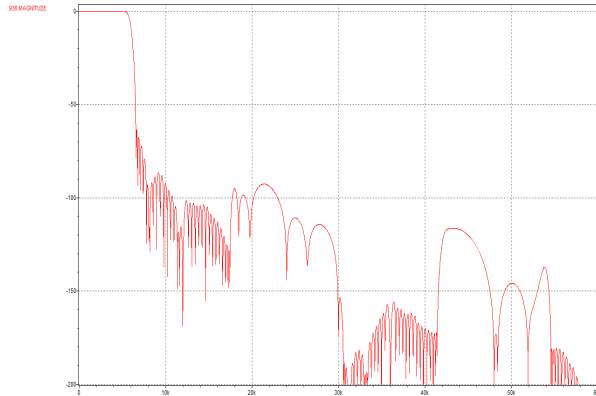
DAC FILTERS		ADC FILTERS	
Mode	Group Delay	Mode	Group Delay
Normal	16.5 / fs	Normal	16.5 / fs
Sloping Stopband	18 / fs		

## TERMINOLOGY

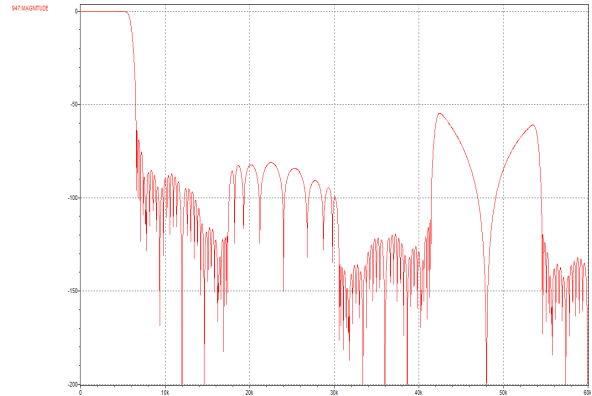
1. Stop Band Attenuation (dB) – the degree to which the frequency spectrum is attenuated (outside audio band)
2. Pass-band Ripple – any variation of the frequency response in the pass-band region



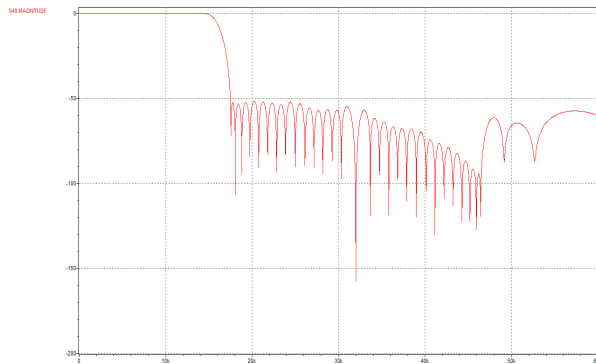
**DAC FILTER RESPONSES**



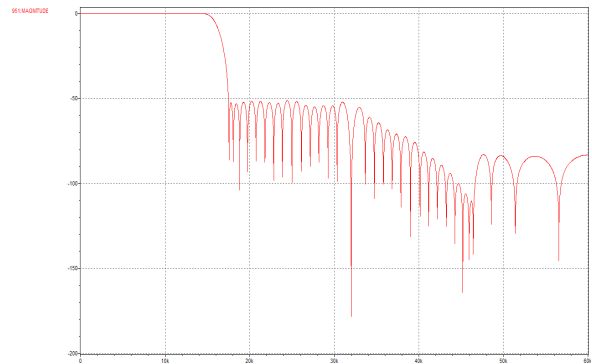
**Figure 6 DAC Filter Response for  
CLK\_SYS\_MODE = 10b (Clock is 250 x fs related)  
DAC\_SB\_FILT = 1b (Sloping StopBand Filter)  
Sample Rate ≤ 24kHz**



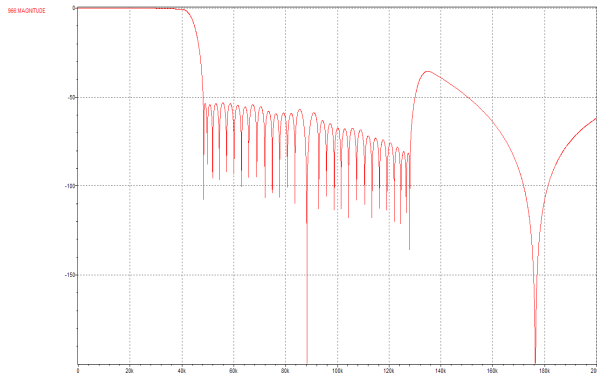
**Figure 7 DAC Filter Response for  
CLK\_SYS\_MODE = 00b or 01b  
DAC\_SB\_FILT = 1b (Sloping StopBand Filter)  
Sample Rate ≤ 24kHz**



**Figure 8 DAC Filter Response for  
CLK\_SYS\_MODE = 10b (Clock is 250 x fs related)  
DAC\_SB\_FILT = 0b (Normal Filter)  
Sample Rate > 24kHz (except 88.2kHz)**

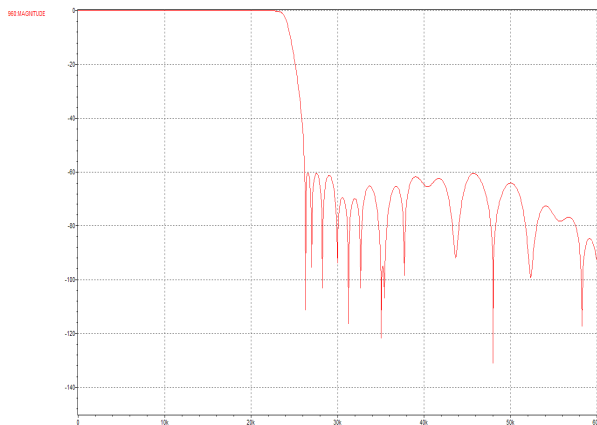


**Figure 9 DAC Filter Response for  
CLK\_SYS\_MODE = 00b or 01b  
DAC\_SB\_FILT = 0b (Normal Filter)  
Sample Rate > 24kHz**

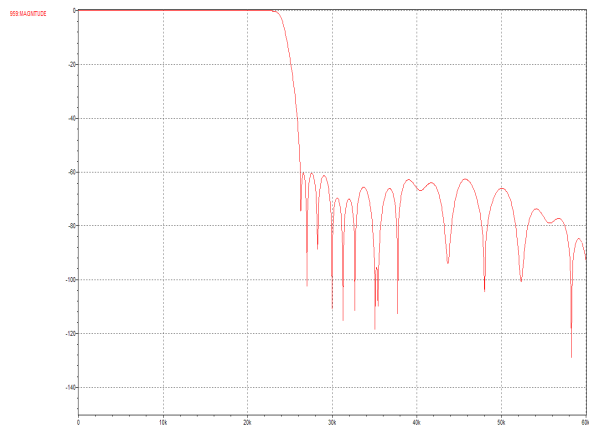


**Figure 10 DAC Filter Response for  
 CLK\_SYS\_MODE = 01b (Clock is 272 x fs related)  
 DAC\_SB\_FILT = 0b (Normal Filter)  
 Sample Rate = 88.2kHz**

**ADC FILTER RESPONSES**



**Figure 11 ADC Filter Response for  
 CLK\_SYS\_MODE = 10b (not applicable to 88.2/96kHz)**



**Figure 12 ADC Filter Response for  
 CLK\_SYS\_MODE = 00b or 01b**

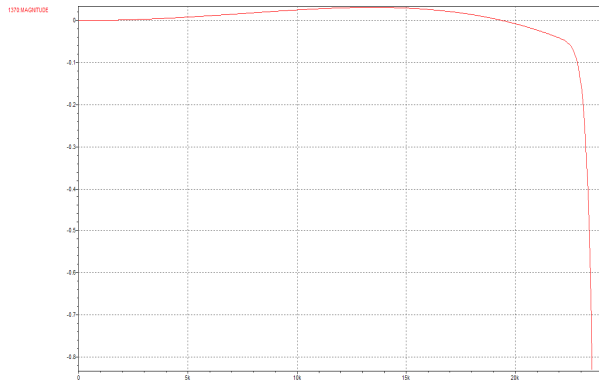


Figure 13 ADC Filter Passband Ripple for CLK\_SYS\_MODE = 10b

ADC HIGH PASS FILTER RESPONSES

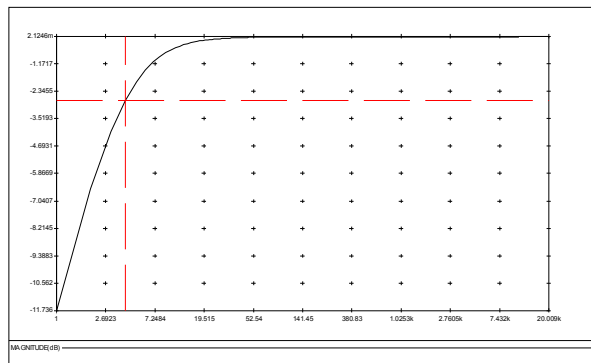


Figure 14 ADC Digital High Pass Filter Frequency Response (48kHz, Hi-Fi Mode, ADC\_HPF\_CUT[1:0]=00)

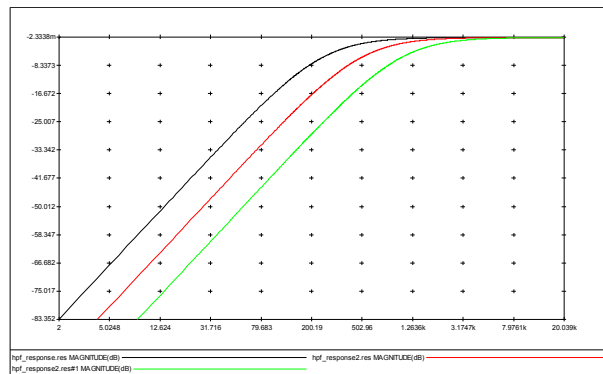


Figure 15 ADC Digital High Pass Filter Ripple (48kHz, Voice Mode, ADC\_HPF\_CUT=01, 10 and 11)

The plots shown are for 48kHz. For other sample rates, the plots should be scaled accordingly.

DE-EMPHASIS FILTER RESPONSES

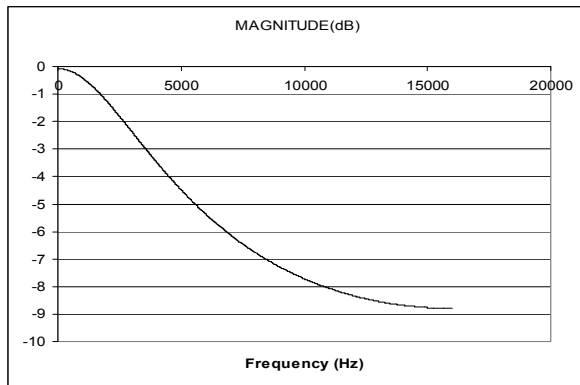


Figure 16 De-Emphasis Digital Filter Response (32kHz)

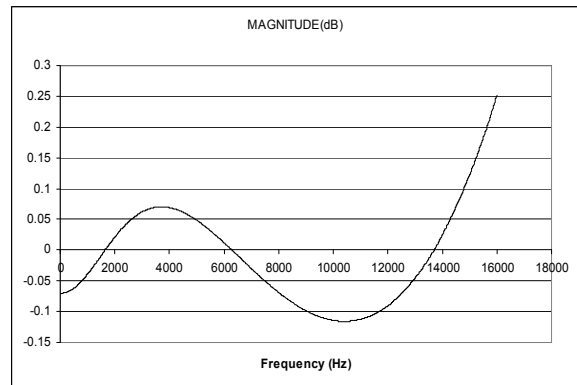


Figure 17 De-Emphasis Error (32kHz)

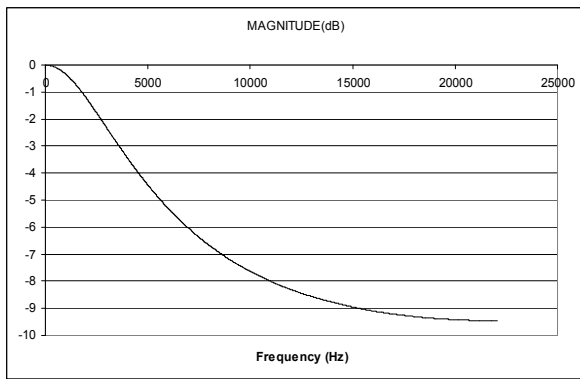


Figure 18 De-Emphasis Digital Filter Response (44.1kHz)

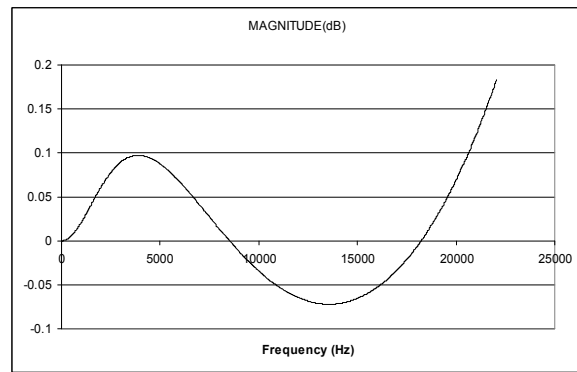


Figure 19 De-Emphasis Error (44.1kHz)

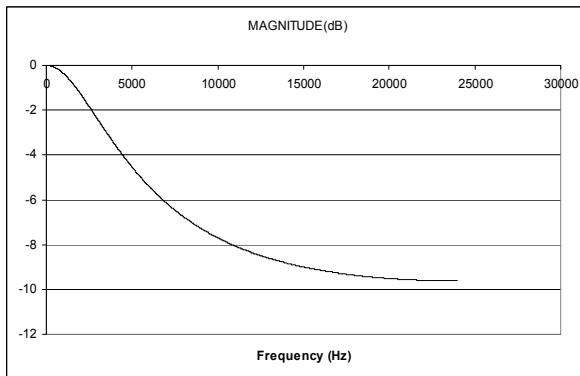


Figure 20 De-Emphasis Digital Filter Response (48kHz)

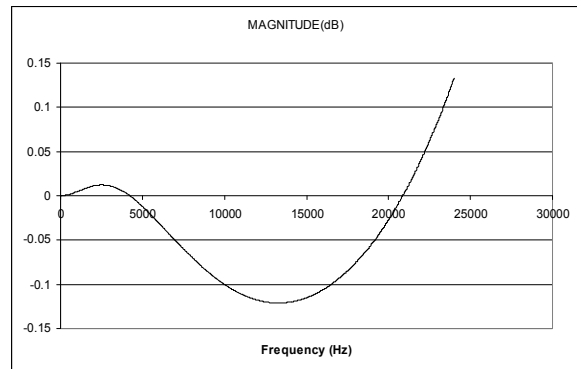


Figure 21 De-Emphasis Error (48kHz)

## DEVICE DESCRIPTION

### INTRODUCTION

The WM8903 is a high performance ultra-low power stereo CODEC optimised for portable audio applications. Flexible analogue interfaces and powerful digital signal processing (DSP) make it ideal for small portable devices.

The WM8903 supports up to 6 analogue audio inputs. One pair of single-ended or differential microphone/line inputs is selected as the ADC input source. An integrated bias reference is provided to power standard electret microphones.

A two-channel digital microphone interface is also supported, with direct input to the DSP core bypassing the ADCs.

Two pairs of ground-referenced Class-W headphone / line outputs are provided; these are powered from an integrated Charge Pump, enabling high quality, power efficient headphone playback without any requirement for DC blocking capacitors. A DC Servo circuit is available for DC offset correction, thereby suppressing pops and reducing power consumption. Two differential line outputs are also provided; these are also capable of driving external speaker drivers. Ground loop feedback is available on the ground-referenced headphone and line outputs, providing rejection of noise on the ground connections. All outputs use Wolfson SilentSwitch™ technology for pop and click suppression.

The stereo ADCs and DACs are of hi-fi quality, using a 24-bit low-order oversampling architecture to deliver optimum performance. A high pass filter is available in the ADC path for removing DC offsets and suppressing low frequency noise such as mechanical vibration and wind noise. A digital mixing path from the ADC to the DAC provides a sidetone of enhanced quality during voice calls. DAC soft mute and un-mute is available for pop-free music playback.

The integrated Dynamic Range Controller (DRC) provides further processing capability of the digital audio paths. The DRC provides compression and signal level control to improve the handling of unpredictable signal levels. 'Anti-clip' and 'quick release' algorithms improve intelligibility in the presence of transients and impulsive noises.

The WM8903 has a highly flexible digital audio interface, supporting a number of protocols, including I2S, DSP, MSB-first left/right justified, and can operate in master or slave modes. PCM operation is supported in the DSP mode. A-law and  $\mu$ -law companding are also supported. Time division multiplexing (TDM) is available to allow multiple devices to stream data simultaneously on the same bus, saving space and power.

The system clock CLK\_SYS provides clocking for the ADCs, DACs, DSP core, digital audio interface and other circuits. CLK\_SYS can be derived directly from the MCLK pin or via an integrated FLL, providing flexibility to support a wide range of clocking schemes. Typical portable system MCLK frequencies, and sample rates from 8kHz to 96kHz are all supported. The clocking circuits are configured automatically from the sample rate (fs) and from the CLK\_SYS / fs ratio.

The integrated FLL can be used to generate CLK\_SYS from a wide variety of different reference sources and frequencies. The FLL can accept a wide range of reference frequencies, which may be high frequency (e.g. 13MHz) or low frequency (eg. 32.768kHz). The FLL is tolerant of jitter and may be used to generate a stable CLK\_SYS from a less stable input signal. The integrated FLL can be used as a free-running oscillator, enabling autonomous clocking of the Charge Pump and DC Servo if required.

The WM8903 uses a standard 2-wire control interface, providing full software control of all features, together with device register readback. An integrated Control Write Sequencer enables automatic scheduling of control sequences; commonly-used signal configurations may be selected using ready-programmed sequences, including time-optimised control of the WM8903 pop suppression features. It is an ideal partner for a wide range of industry standard microprocessors, controllers and DSPs. Unused circuitry can be disabled under software control, in order to save power; low leakage currents enable extended standby/off time in portable battery-powered applications.

Up to 5 GPIO pins may be configured for miscellaneous input/output functions such as button/accessory detect inputs, or for clock, system status, or programmable logic level output for control of additional external circuitry. Interrupt logic, status readback and de-bouncing options are supported within this functionality.

### ANALOGUE INPUT SIGNAL PATH

The WM8903 has six analogue input pins, which may be used to support connections to multiple microphone or line input sources. The input multiplexer on the Left and Right channels can be used to select different configurations for each of the input sources. The analogue input paths can support line and microphone inputs, in single-ended and differential modes. The input stage can also provide common mode noise rejection in some configurations.

The Left and Right analogue input channels are routed to the Analogue to Digital converters (ADCs). There is also a bypass path for each channel, enabling the signal to be routed directly to the output mixers.

The WM8903 input signal paths and control registers are illustrated in Figure 22.

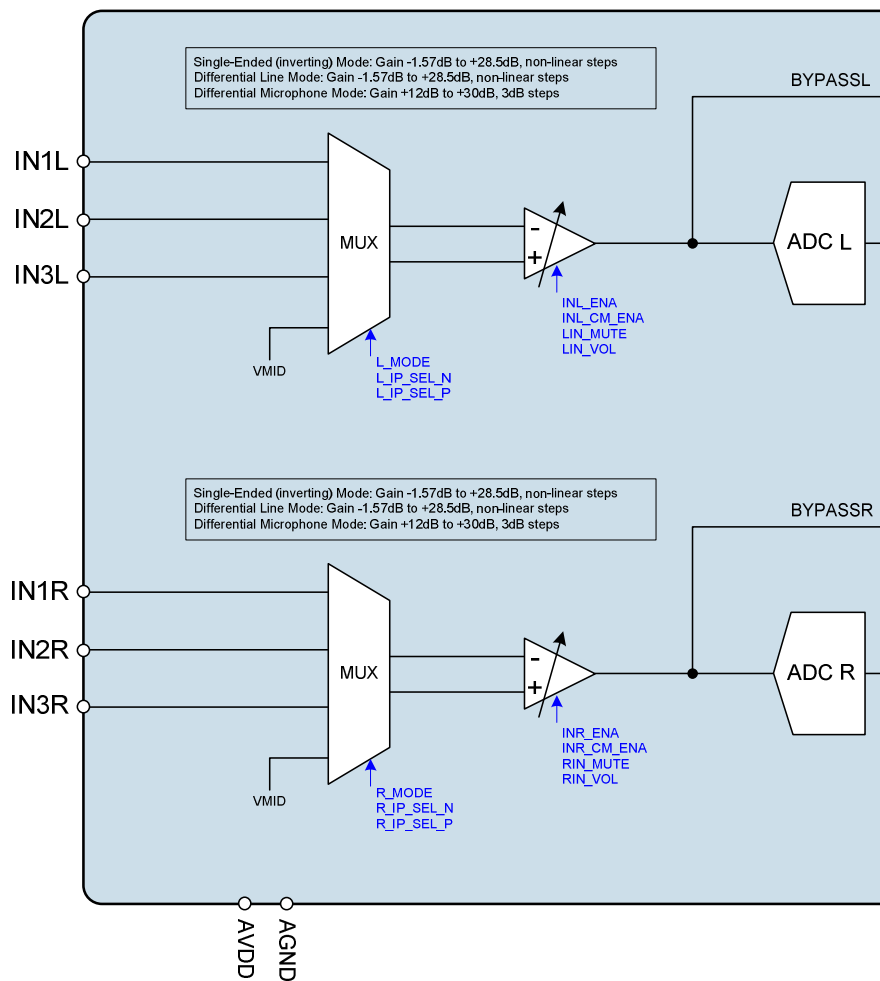


Figure 22 Block Diagram for Input Signal Path

**INPUT PGA ENABLE**

The input PGAs (Programmable Gain Amplifiers) and Multiplexers are enabled using register bits INL\_ENA and INR\_ENA, as shown in Table 1.

REGISTER ADDRESS	BIT	LABEL	DEFAULT	DESCRIPTION
R12 (0Ch) Power Management 0	1	INL_ENA	0	Left Input PGA Enable 0 = disabled 1 = enabled
	0	INR_ENA	0	Right Input PGA Enable 0 = disabled 1 = enabled

**Table 1 Input PGA Enable**

To enable the input PGAs, the reference voltage VMID and the bias current must also be enabled. See "Reference Voltages and Master Bias" for details of the associated controls VMID\_RES and BIAS\_ENA.

**INPUT PGA CONFIGURATION**

The analogue input channels can each be configured in three different modes, which are as follows:

- Single-Ended Mode (Inverting)
- Differential Line Mode
- Differential Mic Mode

The mode is selected by the L\_MODE and R\_MODE fields for the Left and Right channels respectively. The input pins are selected using the L\_IP\_SEL\_N and L\_IP\_SEL\_P fields for the Left channel and the R\_IP\_SEL\_N and R\_IP\_SEL\_P for the Right channel. In Single-Ended mode, L\_IP\_SEL\_N alone determines the Left Input pin, and the R\_IP\_SEL\_N determines the Right Input pin.

The three modes are illustrated in Figure 23, Figure 24 and Figure 25. It should be noted that the available gain and input impedance varies between configurations (see also "Electrical Characteristics"). The input impedance is constant with PGA gain setting.

The Input PGA modes are selected and configured using the register fields described in Table 2.

REGISTER ADDRESS	BIT	LABEL	DEFAULT	DESCRIPTION
R46 (2Eh) Analogue Left Input 1	5:4	L_IP_SEL_N [1:0]	00	In Single-Ended or Differential Line Modes, this field selects the input pin for the inverting side of the left input path.  In Differential Mic Mode, this field selects the input pin for the non-inverting side of the left input path. 00 = IN1L 01 = IN2L 1X = IN3L
	3:2	L_IP_SEL_P [1:0]	01	In Single-Ended or Differential Line Modes, this field selects the input pin for the non-inverting side of the left input path.  In Differential Mic Mode, this field selects the input pin for the inverting side of the left input path. 00 = IN1L 01 = IN2L 1X = IN3L
	1:0	L_MODE [1:0]	00	Sets the mode for the left analogue input: 00 = Single-Ended 01 = Differential Line 10 = Differential MIC 11 = Reserved
R47 (2Fh) Analogue Right Input 1	5:4	R_IP_SEL_N [1:0]	00	In Single-Ended or Differential Line Modes, this field selects the input pin for the inverting side of the right input path.  In Differential Mic Mode, this field selects the input pin for the non-inverting side of the right input path. 00 = IN1R 01 = IN2R 1X = IN3R
	3:2	R_IP_SEL_P [1:0]	01	In Single-Ended or Differential Line Modes, this field selects the input pin for the non-inverting side of the right input path.  In Differential Mic Mode, this field selects the input pin for the inverting side of the right input path. 00 = IN1R 01 = IN2R 1X = IN3R
	1:0	R_MODE [1:0]	00	Sets the mode for the right analogue input: 00 = Single-Ended 01 = Differential Line 10 = Differential MIC 11 = Reserved

Table 2 Input PGA Mode Selection



**SINGLE-ENDED INPUT**

The Single-Ended PGA configuration is illustrated in Figure 23 for the Left channel. The available gain in this mode is from -1.57dB to +28.5dB in non-linear steps. The input impedance is 12kΩ. The input to the ADC is phase inverted with respect to the selected input pin. Different input pins can be selected in the same mode by altering the L\_IP\_SEL\_N field.

The equivalent configuration is also available on the Right channel; this can be selected independently of the Left channel mode.

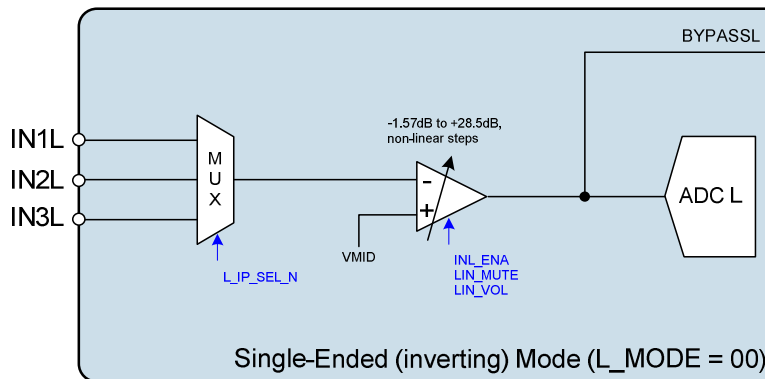


Figure 23 Single Ended Mode

**DIFFERENTIAL LINE INPUT**

The Differential Line PGA configuration is illustrated in Figure 24 for the Left channel. The available gain in this mode is from -1.57dB to +28.5dB in non-linear steps. The input impedance is 12kΩ. The input to the ADC is in phase with the input pin selected by L\_IP\_SEL\_P. The input to the ADC is phase inverted with respect to the input pin selected by L\_IP\_SEL\_N.

As an option, common mode noise rejection can be provided in this PGA configuration, as illustrated in Figure 24. This is enabled using the register bits defined in Table 5.

The equivalent configuration is also available on the Right channel; this can be selected independently of the Left channel mode.

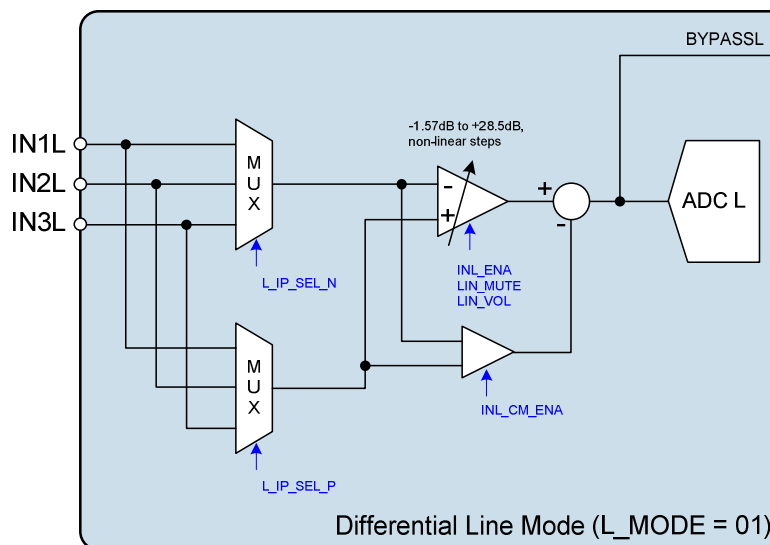


Figure 24 Differential Line Mode

### DIFFERENTIAL MICROPHONE INPUT

The Differential Mic PGA configuration is illustrated in Figure 25 for the Left channel. The available gain in this mode is from +12dB to +30dB in 3dB linear steps. The input impedance is 120k $\Omega$ . The input to the ADC is in phase with the input pin selected by L\_IP\_SEL\_N. The input to the ADC is phase inverted with respect to the input pin selected by L\_IP\_SEL\_P.

Note that the inverting input pin is selected using L\_IP\_SEL\_P and the non-inverting input pin is selected using L\_IP\_SEL\_N. This is not the same as for the Differential Line mode.

The equivalent configuration is also available on the Right channel; this can be selected independently of the Left channel mode.

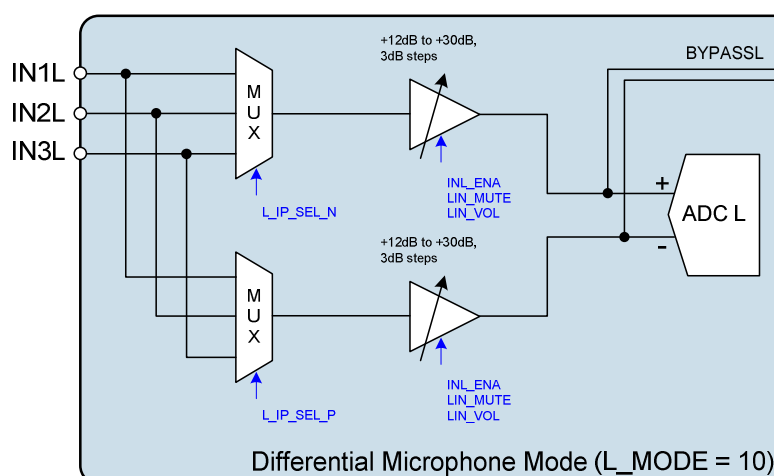


Figure 25 Differential Microphone Mode

### INPUT PGA GAIN CONTROL

The volume control gain for the Left and Right channels be independently controlled using the LIN\_VOL and RIN\_VOL register fields as described in Table 3. The available gain range varies according to the selected PGA Mode as detailed in Table 4. Note that the value '00000' must not be used in Differential Mic Mode, as the PGA will not function correctly under this setting. In single-ended mode (L\_MODE / R\_MODE = 00b), the conversion from single-ended to differential within the WM8903 adds a further 6dB of gain to the signal path.

Each input channel can be independently muted using LINMUTE and RINMUTE.

It is recommended to not adjust the gain dynamically whilst the signal path is enabled; the signal should be muted at the input or output stage prior to adjusting the volume control.

REGISTER ADDRESS	BIT	LABEL	DEFAULT	DESCRIPTION
R44 (2Ch) Analogue Left Input 0	7	LINMUTE	1	Left Input PGA Mute 0 = not muted 1 = muted
	4:0	LIN_VOL [4:0]	00101	Left Input PGA Volume (See Table 4 for volume range)
R45 (2Dh) Analogue Right Input 0	7	RINMUTE	1	Right Input PGA Mute 0 = not muted 1 = muted
	4:0	RIN_VOL [4:0]	00101	Right Input PGA Volume (See Table 4 for volume range)

Table 3 Input PGA Volume Control

LIN_VOL [4:0], RIN_VOL [4:0]	GAIN – SINGLE-ENDED MODE / DIFFERENTIAL LINE MODE	GAIN – DIFFERENTIAL MIC MODE
00000	-1.5 dB	Not valid
00001	-1.3 dB	+12 dB
00010	-1.0 dB	+15 dB
00011	-0.7 dB	+18 dB
00100	-0.3 dB	+21 dB
00101	0.0 dB	+24 dB
00110	+0.3 dB	+27 dB
00111	+0.7 dB	+30 dB
01000	+1.0 dB	+30 dB
01001	+1.4 dB	+30 dB
01010	+1.8 dB	+30 dB
01011	+2.3 dB	+30 dB
01100	+2.7 dB	+30 dB
01101	+3.2 dB	+30 dB
01110	+3.7 dB	+30 dB
01111	+4.2 dB	+30 dB
10000	+4.8 dB	+30 dB
10001	+5.4 dB	+30 dB
10010	+6.0 dB	+30 dB
10011	+6.7 dB	+30 dB
10100	+7.5 dB	+30 dB
10101	+8.3 dB	+30 dB
10110	+9.2 dB	+30 dB
10111	+10.2 dB	+30 dB
11000	+11.4 dB	+30 dB
11001	+12.7 dB	+30 dB
11010	+14.3 dB	+30 dB
11011	+16.2 dB	+30 dB
11100	+19.2 dB	+30 dB
11101	+22.3 dB	+30 dB
11110	+25.2 dB	+30 dB
11111	+28.3 dB	+30 dB

Table 4 Input PGA Volume Range

**INPUT PGA COMMON MODE AMPLIFIER**

In Differential Line Mode only, a Common Mode amplifier can be enabled as part of the input PGA circuit. This feature provides approximately 20dB reduction in common mode noise on the differential input, which can reduce problematic interference. Since the ADC has differential signal inputs, it has an inherent immunity to common mode noise (see “Electrical Characteristics”) However, the presence of Common Mode noise can limit the usable signal range of the ADC path; enabling the Common Mode amplifier can solve this issue.

It should be noted that the Common Mode amplifier consumes additional power and can also add its own noise to the input signal. For these reasons, it is recommended that the Common Mode Amplifier is only enabled if there is a known source of Common Mode interference.

The Common Mode amplifier is controlled by the INL\_CM\_ENA and INR\_CM\_ENA fields as described in Table 5. Although the Common Mode amplifier may be enabled regardless of the input PGA mode, its function is only effective in the Differential Line Mode configuration.

REGISTER ADDRESS	BIT	LABEL	DEFAULT	DESCRIPTION
R46 (2Eh) Analogue Left Input 1	6	INL_CM_ENA	1	Left Input PGA Common Mode Rejection enable 0 = Disabled 1 = Enabled (only available for L_MODE=01 – Differential Line)
R47 (2Fh) Analogue Right Input 1	6	INR_CM_ENA	1	Right Input PGA Common Mode Rejection enable 0 = Disabled 1 = Enabled (only available for R_MODE=01 – Differential Line)

**Table 5 Common Mode Amplifier Enable**

## ELECTRET CONDENSER MICROPHONE INTERFACE

Electret Condenser microphones may be connected as single-ended or differential inputs to the Input PGAs described in the “Analogue Input Signal Path” section. The WM8903 provides a low-noise reference voltage suitable for biasing electret condenser microphones.

The MICBIAS reference is provided on the MICBIAS pin. This reference voltage is enabled by setting the MICBIAS\_ENA register bit, as defined in Table 6.

REGISTER ADDRESS	BIT	LABEL	DEFAULT	DESCRIPTION
R6 (06h) Mic Bias Control 0	0	MICBIAS_ENA	0	MICBIAS Enable 0 = disabled 1 = enabled

**Table 6 MICBIAS Control**

### MICBIAS CURRENT DETECT

A MICBIAS Current Detect function is provided for external accessory detection. This is provided in order to detect the insertion/removal of a microphone or the pressing/releasing of the microphone ‘hook’ switch; these events will cause a significant change in MICBIAS current flow, which can be detected and used to generate a signal to the host processor.

The MICBIAS current detect function is enabled by setting the MICDET\_ENA register bit. When this function is enabled, two current thresholds can be defined, using the MICDET\_THR and MICSHORT\_THR registers. When a change in MICBIAS current which crosses either threshold is detected, then an interrupt event can be generated. In a typical application, accessory insertion would be detected when the MICBIAS current exceeds MICDET\_THR, and microphone hookswitch operation would be detected when the MICBIAS current exceeds MICSHORT\_THR.

The current detect threshold functions are both inputs to the Interrupt control circuit and can be used to trigger an Interrupt event when either threshold is crossed. Both events can also be indicated as an output on a GPIO pin - see “General Purpose Input/Output (GPIO)”.

The current detect thresholds are enabled and controlled using the registers described in Table 7. Performance parameters for this circuit block can be found in the “Electrical Characteristics” section.

Hysteresis and filtering is also provided in the both current detect circuits to improve reliability in conditions where AC current spikes are present due to ambient noise conditions. These features are described in the following section. Further guidance on the usage of the MICBIAS current monitoring features is also described in the following pages.

REGISTER ADDRESS	BIT	LABEL	DEFAULT	DESCRIPTION
R6 (06h) Mic Bias Control 0	5:4	MICDET_THR [1:0]	00	MICBIAS Current Detect Insertion Threshold 00 = 0.063mA 01 = 0.26mA 10 = 0.45mA 11 = 0.635mA Values are scaled with AVDD. Figures shown are based on AVDD=1.8V.
	3:2	MICSHORT_TH R [1:0]	00	MICBIAS Short Circuit Button Push Threshold 00 = 0.52mA 01 = 0.77mA 10 = 1.2mA 11 = 1.43mA Values are scaled with AVDD. Figures shown are based on AVDD=1.8V.

REGISTER ADDRESS	BIT	LABEL	DEFAULT	DESCRIPTION
	1	MICDET_ENA	0	MICBIAS Current and Short Circuit Detect Enable 0 = disabled 1 = enabled

Table 7 MICBIAS Current Detect

### MICBIAS CURRENT DETECT FILTERING

The function of the filtering is to ensure that AC current spikes caused by ambient noise conditions near the microphone do not lead to incorrect signalling of the microphone insertion/removal status or the microphone hookswitch status.

Hysteresis on the current thresholds is provided; this means that a different current threshold is used to detect microphone insertion and microphone removal. Similarly, a different current threshold is used to detect hookswitch press and hookswitch release.

Digital filtering of the hookswitch status ensures that the MICBIAS Short Circuit detection event is only signalled if the MICSHORT\_THR threshold condition has been met for 10 consecutive measurements.

In a typical application, microphone insertion would be detected when the MICBIAS current exceeds the Current Detect threshold set by MICDET\_THR.

When the MICDET\_INV interrupt polarity bit is set to 0, then microphone insertion detection will cause the MICDET\_EINT interrupt status register to be set.

For detection of microphone removal, the MICDET\_INV bit should be set to 1. When the MICDET\_INV interrupt polarity bit is set to 1, then microphone removal detection will cause the MICDET\_EINT interrupt status register to be set.

The detection of these events is bandwidth limited for best noise rejection, and is subject to detection delay time  $t_{DET}$ , as specified in the "Electrical Characteristics". Provided that the MICDET\_THR field has been set appropriately, each insertion or removal event is guaranteed to be detected within the delay time  $t_{DET}$ .

It is likely that the microphone socket contacts will have mechanical "bounce" when a microphone is inserted or removed, and hence the resultant control signal will not be a clean logic level transition. Since  $t_{DET}$  has a range of values, it is possible that the interrupt will be generated before the mechanical "bounce" has ceased. Hence after a mic insertion or removal has been detected, a time delay should be applied before re-configuring the MICDET\_INV bit. The maximum possible mechanical bounce times for mic insertion and removal must be understood by the software programmer.

Utilising a GPIO pin to monitor the steady state of the microphone detection function does not change the timing of the detection mechanism, so there will also be a delay  $t_{DET}$  before the signal changes state. It may be desirable to implement de-bounce in the host processor when monitoring the state of the GPIO signal.

Microphone hook switch operation is detected when the MICBIAS current exceeds the Short Circuit Detect threshold set by MICSHORT\_THR. Using the digital filtering, the hook switch detection event is only signalled if the MICSHORT\_THR threshold condition has been met for 10 consecutive measurements.

When the MICSHT\_INV interrupt polarity bit is set to 0, then hook switch operation will cause the MICSHT\_EINT interrupt status register to be set.

For detection of microphone removal, the MICSHT\_INV bit should be set to 1. When the MICSHT\_INV interrupt polarity bit is set to 1, then hook switch release will cause the MICSHT\_EINT interrupt status register to be set.

The hook switch detection measurement frequency and the detection delay time  $t_{\text{SHORT}}$  are detailed in the “Electrical Characteristics” section.

The WM8903 Interrupt function is described in the “Interrupts” section. Example control sequences for configuring the Interrupts functions for MICBIAS current detection events are described in the “Applications Information” section.

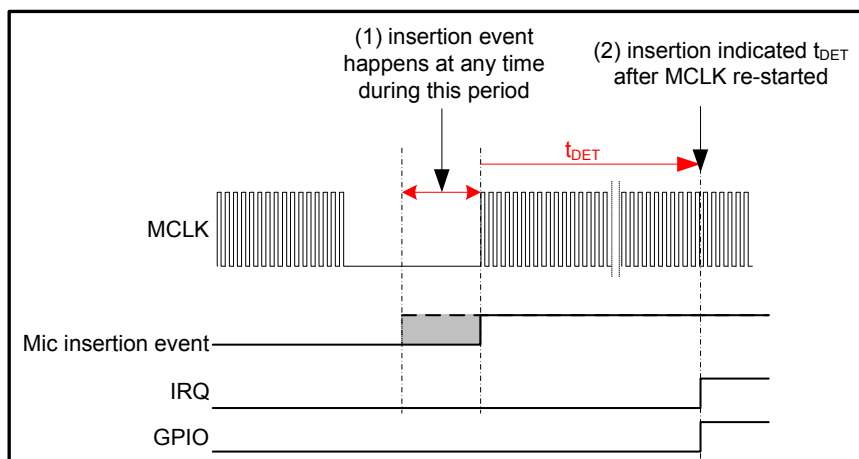
A clock is required for the digital filtering function. This requires:

- MCLK is present
- CLK\_SYS\_ENA = 1
- WSMD\_CLK\_ENA

REGISTER ADDRESS	BIT	LABEL	DEFAULT	DESCRIPTION
R22 (16h) Clock Rates 2	2	CLK_SYS_ENA	0	System Clock enable 0 = Disabled 1 = Enabled
R108 (6Ch) Write Sequencer 0	8	WSMD_CLK_ENA	0	Write Sequencer / Mic Detect Clock Enable. 0 = Disabled 1 = Enabled

**Table 8 MICBIAS Current Detect Clocking**

Any MICBIAS Current Detect event (accessory insertion/removal or hookswitch press/release) which happens while one or more of the clocking criteria is not satisfied (for example during a low power mode where the CPU has disabled MCLK) will still be detected, but only after the clocking conditions are met. An example is illustrated in Figure 26, where the mic is inserted while MCLK is stopped.



**Figure 26 MICBIAS Detection events without MCLK**

### MICROPHONE HOOK SWITCH DETECTION

The possibility of spurious hook switch interrupts due to ambient noise conditions can be removed by careful understanding of the microphone behaviour under extremely high sound pressure levels or during mechanical shock, and by correct selection of the MICBIAS resistor value; these factors will affect the level of the MICBIAS AC current spikes.

In applications where the Current Detect threshold is close to the level of the current spikes, the probability of false detections is reduced by the hysteresis and digital filtering described above.

Note that the filtering algorithm provides only limited rejection of very high current spikes at frequencies less than or equal to the hook switch detect measurement frequency, or at frequencies equal to harmonics of the hook switch detect measurement frequency.

The MICBIAS Hook Switch digital filtering is illustrated in Figure 27. Example control sequences for configuring the Interrupts functions for MICBIAS current detection events are described in the “Applications Information” section.

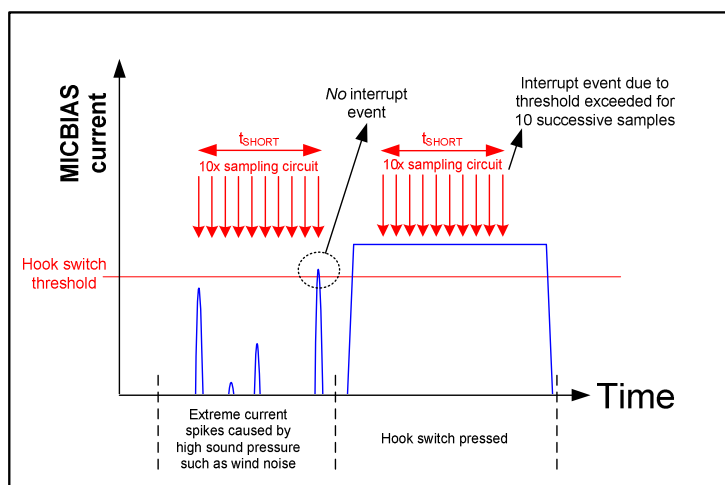


Figure 27 MICBIAS Hook Switch Detect Filtering

## DIGITAL MICROPHONE INTERFACE

The WM8903 supports a two-channel digital microphone interface. The two-channel audio data is multiplexed on the DMIC\_DAT input and clocked by the DMIC\_LR output.

The Digital Microphone Input, DMIC\_DAT, is provided on the GPIO2/DMIC\_DAT pin. The associated clock, DMIC\_LR, is provided on the GPIO1/DMIC\_LR pin.

The Digital Microphone Input is selected as input by setting the ADC\_DIG\_MIC bit. When the Digital Microphone Input is selected, the ADC input is bypassed.

The Digital Microphone Interface configuration is illustrated in Figure 28.

Note that that care must be taken to ensure that the respective digital logic levels of the microphone are compatible with the digital input thresholds of the WM8903. The digital input thresholds are referenced to DBVDD, as defined in “Electrical Characteristics”. It is recommended to power the digital microphones from the same DBVDD supply as WM8903.



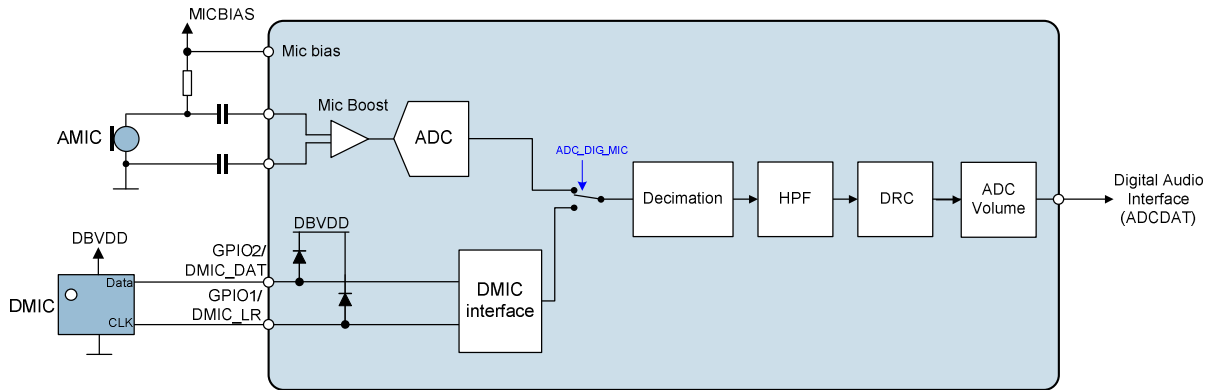


Figure 28 Digital Microphone Interface Control

When GPIO1 is configured as DMIC\_LR Clock output, the WM8903 outputs a clock which supports Digital Mic operation at a multiple of the ADC sampling rate, in the range 1-3MHz. The ADC and Record Path filters must be enabled and the ADC sampling rate must be set in order to ensure correct operation of all DSP functions associated with the digital microphone. Volume control for the Digital Microphone Interface signals is provided using the ADC Volume Control.

See “Analogue-to-Digital Converter (ADC)” for details of the ADC Enable and volume control functions. See “General Purpose Input/Output (GPIO)” for details of configuring the DMIC\_LR and DMIC\_DAT functions. See “Clocking and Sample Rates” for the details of the supported clocking configurations.

When GPIO2/DMIC\_DAT is configured as DMIC\_DAT input, then this pin is the digital microphone input. Up to two microphones can share this pin; the two microphones are interleaved as illustrated in Figure 29.

The digital microphone interface requires that MIC1 transmits a data bit each time that DMIC\_LR is high, and MIC2 transmits when DMIC\_LR is low. The WM8903 samples the digital microphone data in the middle of each DMIC\_LR clock phase. Each microphone must tri-state its data output when the other microphone is transmitting.

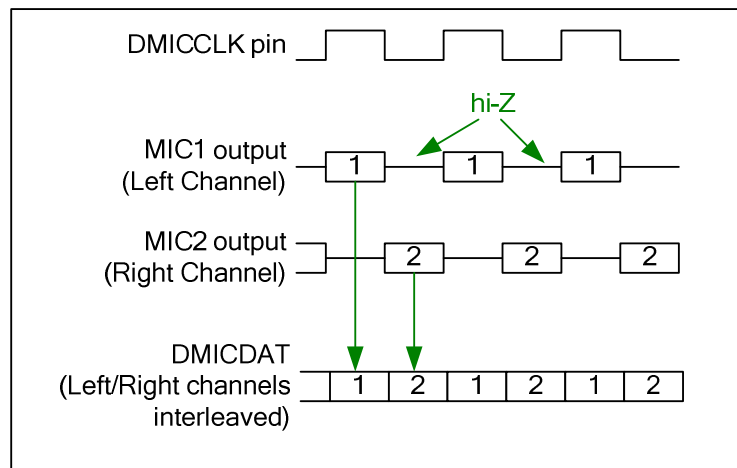


Figure 29 Digital Microphone Interface Timing

The digital microphone interface control fields are described in Table 9.

REGISTER ADDRESS	BIT	LABEL	DEFAULT	DESCRIPTION
R164 (A4h) Clock Rate Test 4	9	ADC_DIG_MIC	0	Enables Digital Microphone mode. 0 = Audio DSP input is from ADC 1 = Audio DSP input is from digital microphone interface

Table 9 Digital Microphone Interface Control

Note that, in addition to setting the ADC\_DIG\_MIC bit as described in Table 9, the pins GPIO1/DMIC\_LR and GPIO2/DMIC\_DAT must also be configured to provide the digital microphone interface function. See "General Purpose Input/Output (GPIO)" for details.

## ANALOGUE-TO-DIGITAL CONVERTER (ADC)

The WM8903 uses two 24-bit, 128x oversampled sigma-delta ADCs. The use of multi-bit feedback and high oversampling rates reduces the effects of jitter and high frequency noise. An oversample rate of 64x can also be supported - see "Clocking and Sample Rates" for details. The ADC full-scale input level is proportional to AVDD - see "Electrical Characteristics". Any input signal greater than full scale may overload the ADC and cause distortion.

The ADCs are enabled by the ADCL\_ENA and ADCR\_ENA register bits.

REGISTER ADDRESS	BIT	LABEL	DEFAULT	DESCRIPTION
R18 (12h) Power Management 6	1	ADCL_ENA	0	Left ADC Enable 0 = disabled 1 = enabled
	0	ADCR_ENA	0	Right ADC Enable 0 = disabled 1 = enabled

Table 10 ADC Enable Control

### ADC DIGITAL VOLUME CONTROL

The output of the ADCs can be digitally amplified or attenuated over a range from -71.625dB to +17.625dB in 0.375dB steps. The volume of each channel can be controlled separately. The gain for a given eight-bit code is detailed in Table 12.

The ADC\_VU bit controls the loading of digital volume control data. When ADC\_VU is set to 0, the ADCL\_VOL or ADCR\_VOL control data is loaded into the respective control register, but does not actually change the digital gain setting. Both left and right gain settings are updated when a 1 is written to ADC\_VU. This makes it possible to update the gain of both channels simultaneously.

REGISTER ADDRESS	BIT	LABEL	DEFAULT	DESCRIPTION
R36 (24h) ADC Digital Volume Left	8	ADCVU	N/A	ADC Volume Update Writing a 1 to this bit causes left and right ADC volume to be updated simultaneously
	7:0	ADCL_VOL [7:0]	1100_0000 (0dB)	Left ADC Digital Volume 00h = Mute 01h = -71.625dB 02h = -71.250dB ... (0.375dB steps) C0h = 0dB ... (0.375dB steps) EFh to FFh = +17.625dB (See Table 12 for volume range)
R37 (25h) ADC Digital Volume Right	8	ADCVU	N/A	ADC Volume Update Writing a 1 to this bit causes left and right ADC volume to be updated simultaneously
	7:0	ADCR_VOL [7:0]	1100_0000 (0dB)	Right ADC Digital Volume 00h = Mute 01h = -71.625dB 02h = -71.250dB ... (0.375dB steps) C0h = 0dB ... (0.375dB steps) EFh to FFh = +17.625dB (See Table 12 for volume range)

Table 11 ADC Digital Volume Control

ADCL_VOL or ADCR_VOL		ADCL_VOL or Volume (dB)		ADCL_VOL or ADCR_VOL		ADCL_VOL or Volume (dB)		ADCL_VOL or ADCR_VOL		ADCL_VOL or Volume (dB)	
0h	MUTE	40h	-48.000	80h	-24.000	C0h	0.000				
1h	-71.625	41h	-47.625	81h	-23.625	C1h	0.375				
2h	-71.250	42h	-47.250	82h	-23.250	C2h	0.750				
3h	-70.875	43h	-46.875	83h	-22.875	C3h	1.125				
4h	-70.500	44h	-46.500	84h	-22.500	C4h	1.500				
5h	-70.125	45h	-46.125	85h	-22.125	C5h	1.875				
6h	-69.750	46h	-45.750	86h	-21.750	C6h	2.250				
7h	-69.375	47h	-45.375	87h	-21.375	C7h	2.625				
8h	-69.000	48h	-45.000	88h	-21.000	C8h	3.000				
9h	-68.625	49h	-44.625	89h	-20.625	C9h	3.375				
Ah	-68.250	4Ah	-44.250	8Ah	-20.250	CAh	3.750				
Bh	-67.875	4Bh	-43.875	8Bh	-19.875	CBh	4.125				
Ch	-67.500	4Ch	-43.500	8Ch	-19.500	CCh	4.500				
Dh	-67.125	4Dh	-43.125	8Dh	-19.125	CDh	4.875				
Eh	-66.750	4Eh	-42.750	8Eh	-18.750	CEh	5.250				
Fh	-66.375	4Fh	-42.375	8Fh	-18.375	CFh	5.625				
10h	-66.000	50h	-42.000	90h	-18.000	D0h	6.000				
11h	-65.625	51h	-41.625	91h	-17.625	D1h	6.375				
12h	-65.250	52h	-41.250	92h	-17.250	D2h	6.750				
13h	-64.875	53h	-40.875	93h	-16.875	D3h	7.125				
14h	-64.500	54h	-40.500	94h	-16.500	D4h	7.500				
15h	-64.125	55h	-40.125	95h	-16.125	D5h	7.875				
16h	-63.750	56h	-39.750	96h	-15.750	D6h	8.250				
17h	-63.375	57h	-39.375	97h	-15.375	D7h	8.625				
18h	-63.000	58h	-39.000	98h	-15.000	D8h	9.000				
19h	-62.625	59h	-38.625	99h	-14.625	D9h	9.375				
1Ah	-62.250	5Ah	-38.250	9Ah	-14.250	DAh	9.750				
1Bh	-61.875	5Bh	-37.875	9Bh	-13.875	DBh	10.125				
1Ch	-61.500	5Ch	-37.500	9Ch	-13.500	DCh	10.500				
1Dh	-61.125	5Dh	-37.125	9Dh	-13.125	DDh	10.875				
1Eh	-60.750	5Eh	-36.750	9Eh	-12.750	DEh	11.250				
1Fh	-60.375	5Fh	-36.375	9Fh	-12.375	DFh	11.625				
20h	-60.000	60h	-36.000	A0h	-12.000	E0h	12.000				
21h	-59.625	61h	-35.625	A1h	-11.625	E1h	12.375				
22h	-59.250	62h	-35.250	A2h	-11.250	E2h	12.750				
23h	-58.875	63h	-34.875	A3h	-10.875	E3h	13.125				
24h	-58.500	64h	-34.500	A4h	-10.500	E4h	13.500				
25h	-58.125	65h	-34.125	A5h	-10.125	E5h	13.875				
26h	-57.750	66h	-33.750	A6h	-9.750	E6h	14.250				
27h	-57.375	67h	-33.375	A7h	-9.375	E7h	14.625				
28h	-57.000	68h	-33.000	A8h	-9.000	E8h	15.000				
29h	-56.625	69h	-32.625	A9h	-8.625	E9h	15.375				
2Ah	-56.250	6Ah	-32.250	AAh	-8.250	EAh	15.750				
2Bh	-55.875	6Bh	-31.875	ABh	-7.875	EBh	16.125				
2Ch	-55.500	6Ch	-31.500	ACh	-7.500	ECh	16.500				
2Dh	-55.125	6Dh	-31.125	ADh	-7.125	EDh	16.875				
2Eh	-54.750	6Eh	-30.750	A Eh	-6.750	EEh	17.250				
2Fh	-54.375	6Fh	-30.375	AFh	-6.375	EFh	17.625				
30h	-54.000	70h	-30.000	B0h	-6.000	F0h	17.625				
31h	-53.625	71h	-29.625	B1h	-5.625	F1h	17.625				
32h	-53.250	72h	-29.250	B2h	-5.250	F2h	17.625				
33h	-52.875	73h	-28.875	B3h	-4.875	F3h	17.625				
34h	-52.500	74h	-28.500	B4h	-4.500	F4h	17.625				
35h	-52.125	75h	-28.125	B5h	-4.125	F5h	17.625				
36h	-51.750	76h	-27.750	B6h	-3.750	F6h	17.625				
37h	-51.375	77h	-27.375	B7h	-3.375	F7h	17.625				
38h	-51.000	78h	-27.000	B8h	-3.000	F8h	17.625				
39h	-50.625	79h	-26.625	B9h	-2.625	F9h	17.625				
3Ah	-50.250	7Ah	-26.250	BAh	-2.250	FAh	17.625				
3Bh	-49.875	7Bh	-25.875	BBh	-1.875	FBh	17.625				
3Ch	-49.500	7Ch	-25.500	BCh	-1.500	FCh	17.625				
3Dh	-49.125	7Dh	-25.125	BDh	-1.125	FDh	17.625				
3Eh	-48.750	7Eh	-24.750	BEh	-0.750	FEh	17.625				
3Fh	-48.375	7Fh	-24.375	BFh	-0.375	FFh	17.625				

Table 12 ADC Digital Volume Range

**HIGH-PASS FILTER (HPF)**

A digital high-pass filter is applied by default to the ADC path to remove DC offsets. This filter can also be programmed to remove low frequency noise in handheld applications (e.g. wind noise, handling noise or mechanical vibration). This filter is controlled using the ADC\_HPF\_ENA and ADC\_HPF\_CUT register bits (see Table 13).

In hi-fi mode the high pass filter is optimised for removing DC offsets without degrading the bass response and has a cut-off frequency of 3.7Hz at fs=44.1kHz.

In voice mode the high pass filter is optimised for voice communication and it is recommended to program the cut-off frequency below 300Hz (e.g. ADC\_HPF\_CUT=11 at fs=8kHz or ADC\_HPF\_CUT=10 at fs=16kHz).

REGISTER ADDRESS	BIT	LABEL	DEFAULT	DESCRIPTION
R38 (26h) ADC Digital 0	6:5	ADC_HPF_CUT [1:0]	00	ADC Digital High Pass Filter Cut-Off Frequency (fc) 00 = Hi-fi mode (fc=4Hz at fs=48kHz) 01 = Voice mode 1 (fc=127Hz at fs=16kHz) 10 = Voice mode 2 (fc=130Hz at fs=8kHz) 11 = Voice mode 3 (fc=267Hz at fs=8kHz) (Note: fc scales with sample rate fs. See Table 14 for cut-off frequencies at all supported sample rates)
	4	ADC_HPF_ENA	1	ADC Digital High Pass Filter Enable 0 = disabled 1 = enabled

**Table 13 ADC High-pass Filter Control Registers**

Sample Rate (kHz)	Value of ADC_HPF_CUT bits			
	00	01	10	11
	Cut-off frequency (Hz)			
8.000	0.7	64	130	267
11.025	0.9	88	178	367
16.000	1.3	127	258	532
22.050	1.9	175	354	733
24.000	2.0	190	386	798
32.000	2.7	253	514	1063
44.100	3.7	348	707	1464
48.000	4.0	379	770	1594
88.200	7.4	696	1414	2928
96.000	8.0	758	1540	3188

**Table 14 ADC High-pass Filter Cut-off Frequencies**

The high pass filter characteristics are shown in "Digital Filter Characteristics" section.

**ADC OVERSAMPLING RATIO (OSR)**

The ADC oversampling rate is programmable to allow power consumption versus audio performance trade-offs. The default oversampling rate is high for best performance; using the lower OSR setting reduces ADC power consumption.

REGISTER ADDRESS	BIT	LABEL	DEFAULT	DESCRIPTION
R10 (0Ah) Analogue ADC 0	0	ADC_OS128	1	ADC Oversampling Ratio 0 = Low Power (64 x fs) 1 = High Performance (128 x fs) Note that the Low Power options is not supported when CLK_SYS_MODE=10

**Table 15 ADC Oversampling Ratio**

Note that the Low Power (64 x fs) oversampling option is not supported when CLK\_SYS\_MODE=10 (see "Clocking and Sample Rates", Table 62).

**DYNAMIC RANGE CONTROL (DRC)**

The dynamic range controller (DRC) is a circuit which can be enabled in the digital data path of the ADC. Its function is to adjust the signal gain in conditions where the input amplitude is unknown or varies over a wide range, e.g. when recording from microphones built into a handheld system. The DRC can apply Compression and Automatic Level Control to the signal path. It incorporates 'anti-clip' and 'quick release' features for handling transients in order to improve intelligibility in the presence of loud impulsive noises.

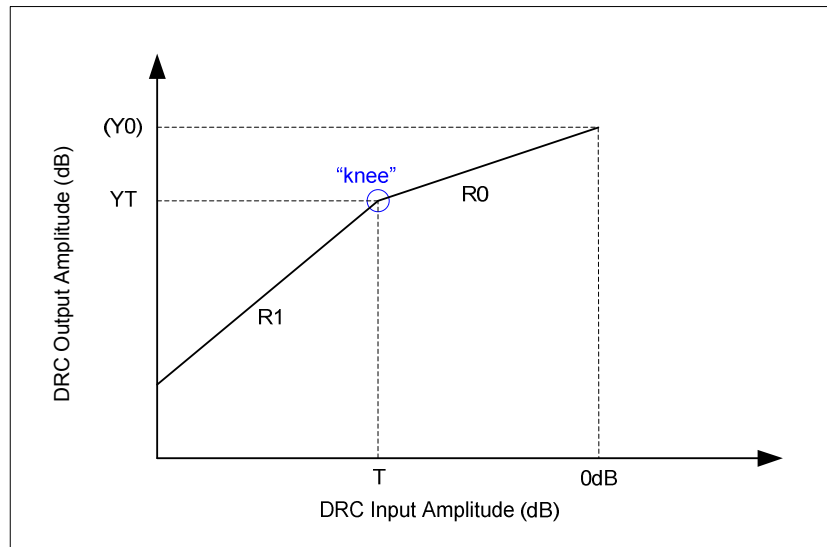
The DRC is enabled as shown in Table 16.

REGISTER ADDRESS	BIT	LABEL	DEFAULT	DESCRIPTION
R40 (28h) DRC 0	15	DRC_ENA	0	DRC enable 1 = enabled 0 = disabled

**Table 16 DRC Enable****COMPRESSION/LIMITING CAPABILITIES**

The DRC supports two different compression regions, specified by R0 and R1, separated by a "knee" at input amplitude T. For signals above the knee, the compression slope R0 applies; for signals below the knee, the compression slope R1 applies.

The overall DRC compression characteristic in "steady state" (i.e. where the input amplitude is near-constant) is illustrated in Figure 30.



**Figure 30 DRC Compression Characteristic**

The slope of R0 and R1 are determined by register fields DRC\_R0\_SLOPE\_COMP and DRC\_R1\_SLOPE\_COMP respectively. A slope of 1 indicates constant gain in this region. A slope less than 1 represents compression (i.e. a change in input amplitude produces only a smaller change in output amplitude). A slope of 0 indicates that the target output amplitude is the same across a range of input amplitudes; this is infinite compression.

The "knee" in Figure 30 is represented by T and Y, which are determined by register fields DRC\_THRESH\_COMP and DRC\_AMP\_COMP respectively.

Parameter Y0, the output level for a 0dB input, is not specified directly, but can be calculated from the other parameters, using the equation

$$Y0 = YT - (T * R0)$$

The DRC Compression parameters are defined in Table 17.

REGISTER ADDRESS	BIT	LABEL	DEFAULT	DESCRIPTION
R42 (2Ah) DRC 2	5:3	DRC_R0_SLOP E_COMP [2:0]	100	Compressor slope R0 000 = 1 (no compression) 001 = 1/2 010 = 1/4 011 = 1/8 100 = 1/16 101 = 0 110 = Reserved 111 = Reserved
	2:0	DRC_R1_SLOP E_COMP [2:0]	000	Compressor slope R1 000 = 1 (no compression) 001 = 1/2 010 = 1/4 011 = 1/8 100 = 0 101 = Reserved 11X = Reserved
R43 (2Bh) DRC 3	10:5	DRC_THRESH_ COMP [5:0]	000000	Compressor threshold T (dB) 000000 = 0dB 000001 = -0.75dB 000010 = -1.5dB ... (-0.75dB steps) 111100 = -45dB 111101 = Reserved 11111X = Reserved
	4:0	DRC_AMP_CO MP [4:0]	00000	Compressor amplitude at threshold YT (dB) 00000 = 0dB 00001 = -0.75dB 00010 = -1.5dB ... (-0.75dB steps) 11110 = -22.5dB 11111 = Reserved

Table 17 DRC Compression Control

**GAIN LIMITS**

The minimum and maximum gain applied by the DRC is set by register fields DRC\_MINGAIN and DRC\_MAXGAIN. These limits can be used to alter the DRC response from that illustrated in Figure 30. If the range between maximum and minimum gain is reduced, then the extent of the dynamic range control is reduced. The maximum gain prevents quiet signals (or silence) from being excessively amplified.



REGISTER ADDRESS	BIT	LABEL	DEFAULT	DESCRIPTION
R41(29h) DRC 1	3:2	DRC_MINGAIN [1:0]	00	Minimum gain the DRC can use to attenuate audio signals 00 = 0dB (default) 01 = -6dB 10 = -12dB 11 = -18dB
	1:0	DRC_MAXGAIN [1:0]	01	Maximum gain the DRC can use to boost audio signals 00 = 12dB 01 = 18dB (default) 10 = 24dB 11 = 36dB

Table 18 DRC Gain Limits

### DYNAMIC CHARACTERISTICS

The dynamic behaviour determines how quickly the DRC responds to changing signal levels. Note that the DRC responds to the average (RMS) signal amplitude over a period of time.

The DRC\_ATTACK\_RATE determines how quickly the DRC gain decreases when the signal amplitude is high. The DRC\_DECAY\_RATE determines how quickly the DRC gain increases when the signal amplitude is low.

These register fields are described in Table 19. Note that the register defaults are suitable for general purpose microphone use.

REGISTER ADDRESS	BIT	LABEL	DEFAULT	DESCRIPTION
R41 (29h) DRC 1	15:12	DRC_ATTACK_RATE [3:0]	0011	Gain attack rate (seconds/6dB) 0000 = Reserved 0001 = 182µs 0010 = 363µs 0011 = 726µs (default) 0100 = 1.45ms 0101 = 2.9ms 0110 = 5.8ms 0111 = 11.6ms 1000 = 23.2ms 1001 = 46.4ms 1010 = 92.8ms 1011-1111 = Reserved
	11:8	DRC_DECAY_RATE [3:0]	0010	Gain decay rate (seconds/6dB) 0000 = 186ms 0001 = 372ms 0010 = 743ms (default) 0011 = 1.49s 0100 = 2.97s 0101 = 5.94s 0110 = 11.89s 0111 = 23.78s 1000 = 47.56s 1001-1111 = Reserved

Table 19 DRC Attack and Decay Rates

**Note:**

For detailed information about DRC attack and decay rates, please see Wolfson application note WAN0247.

**ANTI-CLIP CONTROL**

The DRC includes an Anti-Clip feature to avoid signal clipping when the input amplitude rises very quickly. This feature uses a feed-forward technique for early detection of a rising signal level. Signal clipping is avoided by dynamically increasing the gain attack rate when required. The Anti-Clip feature is enabled using the DRC\_ANTICLIP\_ENA bit.

Note that the feed-forward processing increases the latency in the input signal path. For low-latency applications (e.g. telephony), it may be desirable to reduce the delay, although this will also reduce the effectiveness of the anti-clip feature. The latency is determined by the DRC\_FF\_DELAY bit. If necessary, the latency can be minimised by disabling the anti-clip feature altogether.

The DRC Anti-Clip control bits are described in Table 20.

REGISTER ADDRESS	BIT	LABEL	DEFAULT	DESCRIPTION
R40 (28h) DRC 0	5	DRC_FF_DELAY	1	Feed-forward delay for anti-clip feature 0 = 5 samples 1 = 9 samples Time delay can be calculated as $5/f_s$ or $9/f_s$ , where $f_s$ is the sample rate.
	1	DRC_ANTICLIP_ENA	1	Anti-clip enable 0 = disabled 1 = enabled

**Table 20 DRC Anti-Clip Control**

Note that the Anti-Clip feature operates entirely in the digital domain, i.e. after the ADC. It cannot be used to prevent signal clipping in the analogue domain (e.g. in the input PGAs or ADCs), nor in the source signal. Analogue clipping can only be prevented by reducing the analogue signal gain or by adjusting the source signal.

**QUICK RELEASE CONTROL**

The DRC includes a Quick-Release feature to handle short transient peaks that are not related to the intended source signal. For example, in handheld microphone recording, transient signal peaks sometimes occur due to user handling, key presses or accidental tapping against the microphone. The Quick Release feature ensures that these transients do not cause the intended signal to be masked by the longer time constants of DRC\_DECAY\_RATE.

The Quick-Release feature is enabled by setting the DRC\_QR\_ENA bit. When this bit is enabled, the DRC measures the crest factor (peak to RMS ratio) of the input signal. A high crest factor is indicative of a transient peak that may not be related to the intended source signal. If the crest factor exceeds the level set by DRC\_THRESH\_QR, then the normal decay rate (DRC\_DECAY\_RATE) is ignored and a faster decay rate (DRC\_RATE\_QR) is used instead.

The DRC Quick-Release control bits are described in Table 21.

REGISTER ADDRESS	BIT	LABEL	DEFAULT	DESCRIPTION
R40 (28h) DRC 0	2	DRC_QR_ENA	1	Quick release enable 0 = disabled 1 = enabled
R41 (29h) DRC 1	7:6	DRC_THRESH_QR [1:0]	01	Quick release crest factor threshold 00 = 12dB 01 = 18dB (default) 10 = 24dB 11 = 30dB
	5:4	DRC_RATE_QR [1:0]	00	Quick release decay rate (seconds/6dB) 00 = 0.725ms (default) 01 = 1.45ms 10 = 5.8ms 11 = Reserved

Table 21 DRC Quick-Release Control

### GAIN SMOOTHING

The DRC includes a gain smoothing filter in order to prevent gain ripples. A programmable level of hysteresis is also used to control the DRC gain. This improves the handling of very low frequency input signals whose period is close to the DRC attack/decay time. DRC Gain Smoothing is enabled by default and it is recommended to use the default register settings.

The extent of the gain smoothing filter may be adjusted or disabled using the control fields described in Table 22.

REGISTER ADDRESS	BIT	LABEL	DEFAULT	DESCRIPTION
R40 (28h) DRC 0	12:11	DRC_THRESH_HYST [1:0]	01	Gain smoothing hysteresis threshold 00 = Low 01 = Medium (recommended) 10 = High 11 = Reserved
	3	DRC_SMOOTH_ENA	1	Gain smoothing enable 0 = disabled 1 = enabled
	0	DRC_HYST_ENA	1	Gain smoothing hysteresis enable 0 = disabled 1 = enabled

Table 22 DRC Gain Smoothing

**INITIALISATION**

When the DRC is initialised, the gain is set to the level determined by the DRC\_STARTUP\_GAIN register field. The default setting is 0dB, but values from -18dB to +36dB are available, as described in Table 23.

REGISTER ADDRESS	BIT	LABEL	DEFAULT	DESCRIPTION
R40 (28h) DRC 0	10:6	DRC_STARTUP_GAIN [4:0]	00110	Initial gain at DRC startup 00000 = -18dB 00001 = -15dB 00010 = -12dB 00011 = -9dB 00100 = -6dB 00101 = -3dB 00110 = 0dB (default) 00111 = 3dB 01000 = 6dB 01001 = 9dB 01010 = 12dB 01011 = 15dB 01100 = 18dB 01101 = 21dB 01110 = 24dB 01111 = 27dB 10000 = 30dB 10001 = 33dB 10010 = 36dB 10011 to 11111 = Reserved

**Table 23 DRC Initialisation**

## DIGITAL MIXING

The ADC and DAC data can be combined in various ways to support a range of different usage modes.

Data from either of the two ADCs can be routed to either the left or the right channel of the digital audio interface. In addition, data from either of the digital audio interface channels can be routed to either the left or the right DAC. See “Digital Audio Interface” for more information on the audio interface.

The WM8903 provides a Dynamic Range Control (DRC) feature, which can apply compression and gain adjustment in the digital domain to the ADC signal path. This is effective in controlling signal levels under conditions where input amplitude is unknown or varies over a wide range.

The DACs can be configured as a mono mix of the two audio channels. Digital sidetone from the ADCs can also be selectively mixed into the DAC output path.

### DIGITAL MIXING PATHS

Figure 31 shows the digital mixing paths available in the WM8903 digital core.

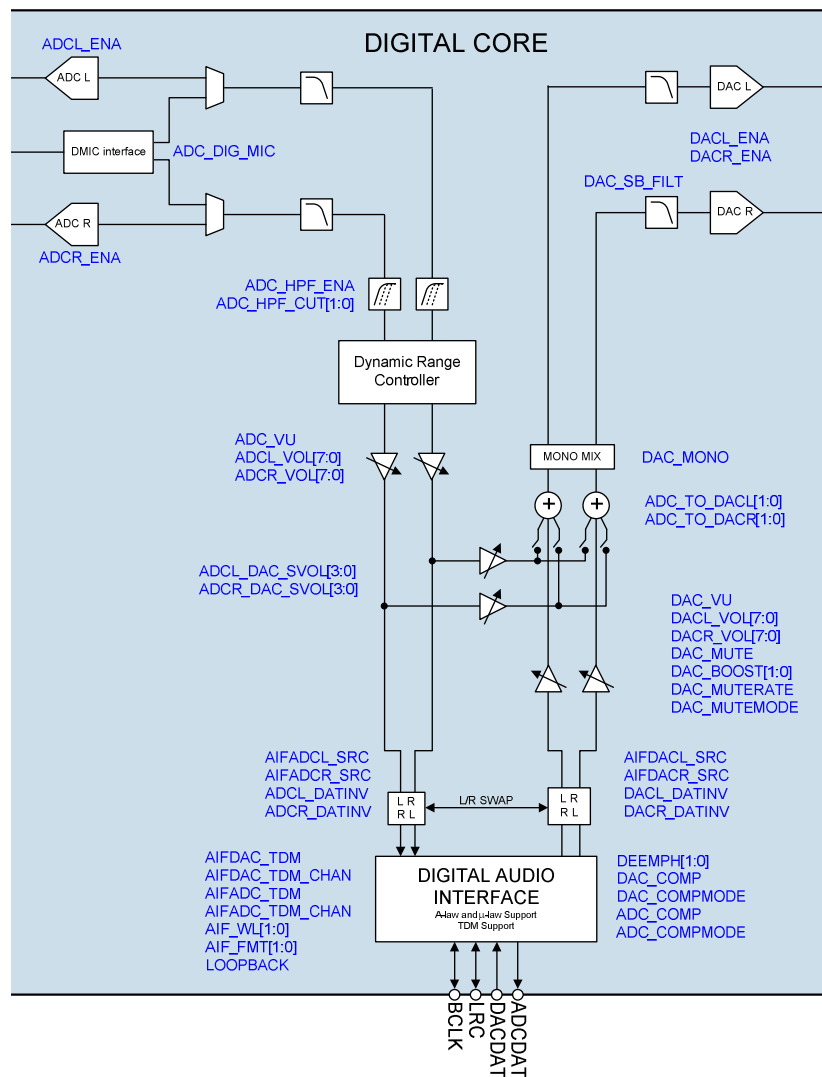


Figure 31 Digital Mixing Paths

The polarity of each ADC output signal can be changed under software control using the ADCL\_DATINV and ADCR\_DATINV register bits. The AIFADCL\_SRC and AIFADCR\_SRC register bits may be used to select which ADC is used for the left and right digital audio interface data. These register bits are described in Table 24.

REGISTER ADDRESS	BIT	LABEL	DEFAULT	DESCRIPTION
R24 (18h) Audio Interface 0	7	AIFADCL_SRC	0	Left Digital Audio channel source 0 = Left ADC data is output on left channel 1 = Right ADC data is output on left channel
	6	AIFADCR_SRC	1	Right Digital Audio channel source 0 = Left ADC data is output on right channel 1 = Right ADC data is output on right channel
R38 (26h) ADC Digital 0	1	ADCL_DATINV	0	Left ADC Invert 0 = Left ADC output not inverted 1 = Left ADC output inverted
	0	ADCR_DATINV	0	Right ADC Invert 0 = Right ADC output not inverted 1 = Right ADC output inverted

Table 24 ADC Routing and Control

The input data source for each DAC can be changed under software control using register bits DACL\_SRC and DACR\_SRC. The polarity of each DAC input may also be modified using register bits DACL\_DATINV and DACR\_DATINV. These register bits are described in Table 25.

REGISTER ADDRESS	BIT	LABEL	DEFAULT	DESCRIPTION
R24 (18h) Audio Interface 0	12	DACL_DATINV	0	Left DAC Invert 0 = Left DAC output not inverted 1 = Left DAC output inverted
	11	DACR_DATINV	0	Right DAC Invert 0 = Right DAC output not inverted 1 = Right DAC output inverted
	5	AIFDACL_SRC	0	Left DAC Data Source Select 0 = Left DAC outputs left channel data 1 = Left DAC outputs right channel data
	4	AIFDACR_SRC	1	Right DAC Data Source Select 0 = Right DAC outputs left channel data 1 = Right DAC outputs right channel data

Table 25 DAC Routing and Control

### DAC INTERFACE VOLUME BOOST

A digital gain function is available at the audio interface to boost the DAC volume when a small signal is received on DACDAT. This is controlled using register bits DAC\_BOOST [1:0]. To prevent clipping at the DAC input, this function should not be used when the boosted DAC data is expected to be greater than 0dBFS.

The digital interface volume is controlled as shown in Table 26.

REGISTER ADDRESS	BIT	LABEL	DEFAULT	DESCRIPTION
R24 (18h) Audio Interface 0	10:9	DAC_BOOST [1:0]	00	DAC Input Volume Boost 00 = 0dB 01 = +6dB (Input data must not exceed -6dBFS) 10 = +12dB (Input data must not exceed -12dBFS) 11 = +18dB (Input data must not exceed -18dBFS)

Table 26 DAC Interface Volume Boost

### DIGITAL SIDETONE

Digital sidetone mixing (from ADC output into DAC input) is available when ADCs and DACs are operating at the same sample rate. Digital data from either left or right ADC can be mixed with the audio interface data on the left and right DAC channels. Sidetone data is taken from the ADC high-pass filter output, to reduce low frequency noise in the sidetone (e.g. wind noise or mechanical vibration).

When using the digital sidetone, it is recommended that the ADCs are enabled before un-muting the DACs to prevent pop noise. The DAC volumes and sidetone volumes should be set to an appropriate level to avoid clipping at the DAC input.

When digital sidetone is used, it is recommended that the Charge Pump operates in Register Control mode only (CP\_DYN\_PWR = 0). See "Charge Pump" for details.

The digital sidetone is controlled as shown in Table 27.

REGISTER ADDRESS	BIT	LABEL	DEFAULT	DESCRIPTION
R32 (20h) DAC Digital 0	11:8	ADCL_DAC_SV OL [3:0]	0000	Left Digital Sidetone Volume 0000 = -36dB 0001 = -33dB (... 3dB steps) 1011 = -3dB 11XX = 0dB (See Table 28 for volume range)
	7:4	ADCR_DAC_SV OL [3:0]	0000	Right Digital Sidetone Volume 0000 = -36dB 0001 = -33dB (... 3dB steps) 1011 = -3dB 11XX = 0dB (See Table 28 for volume range)
	3:2	ADC_TO_DACL [1:0]	00	Left DAC Digital Sidetone Source 00 = No sidetone 01 = Left ADC 10 = Right ADC 11 = Reserved
	1:0	ADC_TO_DACR [1:0]	00	Right DAC Digital Sidetone Source 00 = No sidetone 01 = Left ADC 10 = Right ADC 11 = Reserved

Table 27 Digital Sidetone Control

The digital sidetone volume settings are shown in Table 28.

ADCL_DAC_SVOL OR ADCR_DAC_SVOL	SIDETONE VOLUME
0000	-36
0001	-33
0010	-30
0011	-27
0100	-24
0101	-21
0110	-18
0111	-15
1000	-12
1001	-9
1010	-6
1011	-3
1100	0
1101	0
1110	0
1111	0

Table 28 Digital Sidetone Volume

## DIGITAL-TO-ANALOGUE CONVERTER (DAC)

The WM8903 DACs receive digital input data from the DACDAT pin and via the digital sidetone path (see “Digital Mixing” section). The digital audio data is converted to oversampled bit streams in the on-chip, true 24-bit digital interpolation filters. The bitstream data enters two multi-bit, sigma-delta DACs, which convert them to high quality analogue audio signals. The Wolfson SmartDAC™ architecture offers reduced power consumption, whilst also delivering a reduction in high frequency noise and sensitivity to clock jitter. It also uses a Dynamic Element Matching technique for high linearity and low distortion.

The analogue outputs from the DACs can then be mixed with other analogue inputs before being sent to the analogue output pins (see “Output Signal Path”).

The DACs are enabled by the DACL\_ENA and DACR\_ENA register bits.

REGISTER ADDRESS	BIT	LABEL	DEFAULT	DESCRIPTION
R18 (12h) Power Management 6	3	DACL_ENA	0	Left DAC Enable 0 = DAC disabled 1 = DAC enabled
	2	DACR_ENA	0	Right DAC Enable 0 = DAC disabled 1 = DAC enabled

Table 29 DAC Enable Control

### DAC DIGITAL VOLUME CONTROL

The output level of each DAC can be controlled digitally over a range from -71.625dB to 0dB in 0.375dB steps. The level of attenuation for an eight-bit code is detailed in Table 31.

The DAC\_VU bit controls the loading of digital volume control data. When DAC\_VU is set to 0, the DACL\_VOL or DACR\_VOL control data is loaded into the respective control register, but does not actually change the digital gain setting. Both left and right gain settings are updated when a 1 is written to DAC\_VU. This makes it possible to update the gain of both channels simultaneously.



REGISTER ADDRESS	BIT	LABEL	DEFAULT	DESCRIPTION
R30 (1Eh) DAC Digital Volume Left	8	DACVU	N/A	DAC Volume Update Writing a 1 to this bit causes left and right DAC volume to be updated simultaneously
	7:0	DACL_VOL [7:0]	1100_0000 (0dB)	Left DAC Digital Volume 00h = Mute 01h = -71.625dB 02h = -71.250dB ... (0.375dB steps) C0h = 0dB ... (0.375dB steps) EFh to FFh = +17.625dB (See Table 31 for volume range)
R31 (1Fh) DAC Digital Volume Right	8	DACVU	N/A	DAC Volume Update Writing a 1 to this bit causes left and right DAC volume to be updated simultaneously
	7:0	DACR_VOL [7:0]	1100_0000 (0dB)	Right DAC Digital Volume 00h = Mute 01h = -71.625dB 02h = -71.250dB ... (0.375dB steps) C0h = 0dB ... (0.375dB steps) EFh to FFh = +17.625dB (See Table 31 for volume range)

Table 30 DAC Digital Volume Control

DACL_VOL or DACR_VOL		DACL_VOL or Volume (dB)		DACL_VOL or DACR_VOL		DACL_VOL or Volume (dB)		DACL_VOL or DACR_VOL		DACL_VOL or Volume (dB)	
0h	MUTE	40h	-48.000	80h	-24.000	C0h	0.000				
1h	-71.625	41h	-47.625	81h	-23.625	C1h	0.000				
2h	-71.250	42h	-47.250	82h	-23.250	C2h	0.000				
3h	-70.875	43h	-46.875	83h	-22.875	C3h	0.000				
4h	-70.500	44h	-46.500	84h	-22.500	C4h	0.000				
5h	-70.125	45h	-46.125	85h	-22.125	C5h	0.000				
6h	-69.750	46h	-45.750	86h	-21.750	C6h	0.000				
7h	-69.375	47h	-45.375	87h	-21.375	C7h	0.000				
8h	-69.000	48h	-45.000	88h	-21.000	C8h	0.000				
9h	-68.625	49h	-44.625	89h	-20.625	C9h	0.000				
Ah	-68.250	4Ah	-44.250	8Ah	-20.250	CAh	0.000				
Bh	-67.875	4Bh	-43.875	8Bh	-19.875	CBh	0.000				
Ch	-67.500	4Ch	-43.500	8Ch	-19.500	CCh	0.000				
Dh	-67.125	4Dh	-43.125	8Dh	-19.125	CDh	0.000				
Eh	-66.750	4Eh	-42.750	8Eh	-18.750	CEh	0.000				
Fh	-66.375	4Fh	-42.375	8Fh	-18.375	CFh	0.000				
10h	-66.000	50h	-42.000	90h	-18.000	D0h	0.000				
11h	-65.625	51h	-41.625	91h	-17.625	D1h	0.000				
12h	-65.250	52h	-41.250	92h	-17.250	D2h	0.000				
13h	-64.875	53h	-40.875	93h	-16.875	D3h	0.000				
14h	-64.500	54h	-40.500	94h	-16.500	D4h	0.000				
15h	-64.125	55h	-40.125	95h	-16.125	D5h	0.000				
16h	-63.750	56h	-39.750	96h	-15.750	D6h	0.000				
17h	-63.375	57h	-39.375	97h	-15.375	D7h	0.000				
18h	-63.000	58h	-39.000	98h	-15.000	D8h	0.000				
19h	-62.625	59h	-38.625	99h	-14.625	D9h	0.000				
1Ah	-62.250	5Ah	-38.250	9Ah	-14.250	DAh	0.000				
1Bh	-61.875	5Bh	-37.875	9Bh	-13.875	DBh	0.000				
1Ch	-61.500	5Ch	-37.500	9Ch	-13.500	DCh	0.000				
1Dh	-61.125	5Dh	-37.125	9Dh	-13.125	DDh	0.000				
1Eh	-60.750	5Eh	-36.750	9Eh	-12.750	DEh	0.000				
1Fh	-60.375	5Fh	-36.375	9Fh	-12.375	DFh	0.000				
20h	-60.000	60h	-36.000	A0h	-12.000	E0h	0.000				
21h	-59.625	61h	-35.625	A1h	-11.625	E1h	0.000				
22h	-59.250	62h	-35.250	A2h	-11.250	E2h	0.000				
23h	-58.875	63h	-34.875	A3h	-10.875	E3h	0.000				
24h	-58.500	64h	-34.500	A4h	-10.500	E4h	0.000				
25h	-58.125	65h	-34.125	A5h	-10.125	E5h	0.000				
26h	-57.750	66h	-33.750	A6h	-9.750	E6h	0.000				
27h	-57.375	67h	-33.375	A7h	-9.375	E7h	0.000				
28h	-57.000	68h	-33.000	A8h	-9.000	E8h	0.000				
29h	-56.625	69h	-32.625	A9h	-8.625	E9h	0.000				
2Ah	-56.250	6Ah	-32.250	AAh	-8.250	EAh	0.000				
2Bh	-55.875	6Bh	-31.875	ABh	-7.875	EBh	0.000				
2Ch	-55.500	6Ch	-31.500	ACh	-7.500	ECh	0.000				
2Dh	-55.125	6Dh	-31.125	ADh	-7.125	EDh	0.000				
2Eh	-54.750	6Eh	-30.750	AEdh	-6.750	EEh	0.000				
2Fh	-54.375	6Fh	-30.375	AFh	-6.375	EFh	0.000				
30h	-54.000	70h	-30.000	B0h	-6.000	F0h	0.000				
31h	-53.625	71h	-29.625	B1h	-5.625	F1h	0.000				
32h	-53.250	72h	-29.250	B2h	-5.250	F2h	0.000				
33h	-52.875	73h	-28.875	B3h	-4.875	F3h	0.000				
34h	-52.500	74h	-28.500	B4h	-4.500	F4h	0.000				
35h	-52.125	75h	-28.125	B5h	-4.125	F5h	0.000				
36h	-51.750	76h	-27.750	B6h	-3.750	F6h	0.000				
37h	-51.375	77h	-27.375	B7h	-3.375	F7h	0.000				
38h	-51.000	78h	-27.000	B8h	-3.000	F8h	0.000				
39h	-50.625	79h	-26.625	B9h	-2.625	F9h	0.000				
3Ah	-50.250	7Ah	-26.250	BAh	-2.250	FAh	0.000				
3Bh	-49.875	7Bh	-25.875	BBh	-1.875	FBh	0.000				
3Ch	-49.500	7Ch	-25.500	BCh	-1.500	FCh	0.000				
3Dh	-49.125	7Dh	-25.125	BDh	-1.125	FDh	0.000				
3Eh	-48.750	7Eh	-24.750	BEh	-0.750	FEh	0.000				
3Fh	-48.375	7Fh	-24.375	BFh	-0.375	FFh	0.000				

Table 31 DAC Digital Volume Range

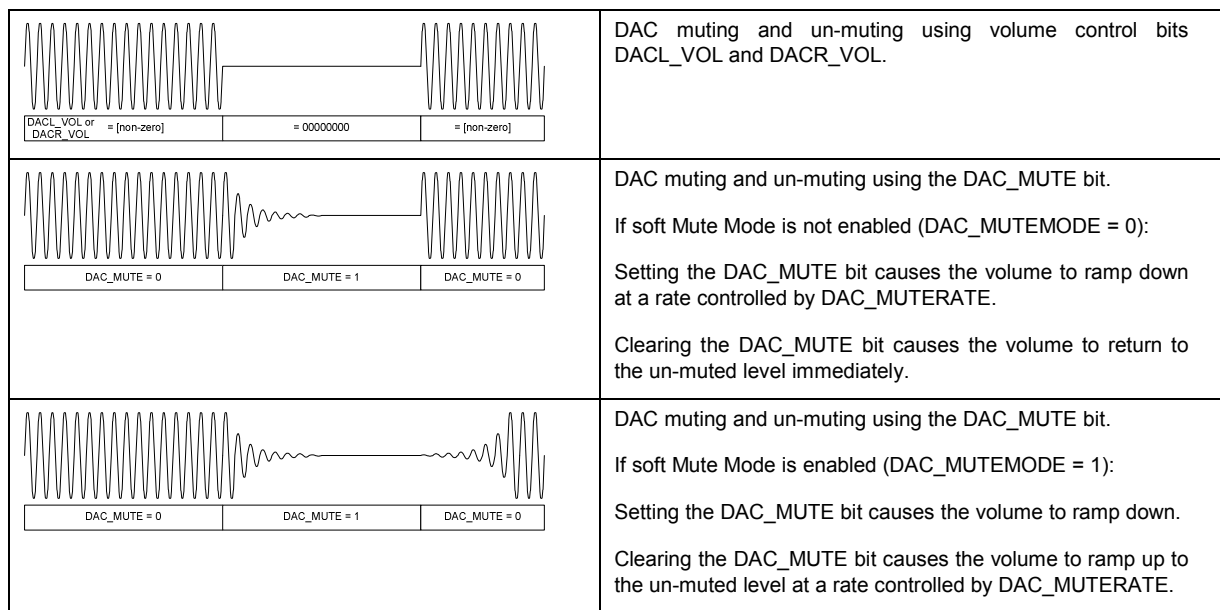
**DAC SOFT MUTE AND SOFT UN-MUTE**

The WM8903 has a soft mute function. When enabled, this gradually attenuates the volume of the DAC output. When soft mute is disabled, the gain will either gradually ramp back up to the digital gain setting, or return instantly to the digital gain setting, depending on the DAC\_MUTEMODE register bit.

The DAC is not muted by default (DAC\_MUTE = 0). To mute the DAC, this function must be enabled by setting DAC\_MUTE to 1.

Soft Mute Mode would typically be enabled (DAC\_MUTEMODE = 1) when using DAC\_MUTE during playback of audio data so that when DAC\_MUTE is subsequently disabled, the sudden volume increase will not create pop noise by jumping immediately to the previous volume level (e.g. resuming playback after pausing during a track).

Soft Mute Mode would typically be disabled (DAC\_MUTEMODE = 0) when un-muting at the start of a music file, in order that the first part of the track is not attenuated (e.g. when starting playback of a new track, or resuming playback after pausing between tracks).



**Figure 32 DAC Mute Control**

The volume ramp rate during soft mute and un-mute is controlled by the DAC\_MUTERATE bit. Ramp rates of fs/32 and fs/2 can be selected, as shown in Table 32. The ramp rate determines the rate at which the volume is increased or decreased. The actual ramp time depends on the extent of the difference between the muted and un-muted volume settings.

REGISTER ADDRESS	BIT	LABEL	DEFAULT	DESCRIPTION
R33 (21h) DAC Digital 1	10	DAC_MUTERATE	0	DAC Soft Mute Ramp Rate 0 = Fast ramp (fs/2, maximum ramp time is 10.7ms at fs=48k) 1 = Slow ramp (fs/32, maximum ramp time is 171ms at fs=48k)
	9	DAC_MUTE MODE	0	DAC Soft Mute Mode 0 = Disabling soft-mute (DAC_MUTE=0) will cause the DAC volume to change immediately to DACL_VOL and DACR_VOL settings 1 = Disabling soft-mute (DAC_MUTE=0) will cause the DAC volume to ramp up gradually to the DACL_VOL and DACR_VOL settings
	3	DAC_MUTE	0	DAC Soft Mute Control 0 = DAC Un-mute 1 = DAC Mute

Table 32 DAC Soft-Mute Control

### DAC MONO MIX

A DAC digital mono-mix mode can be enabled using the DAC\_MONO register bit. This mono mix will be output on whichever DAC is enabled. To prevent clipping, a -6dB attenuation is automatically applied to the mono mix.

The mono mix is only supported when one or other DAC is disabled. When the mono mix is selected, then the mono mix is output on the enabled DAC only; there is no output from the disabled DAC. If DACL\_ENA and DACR\_ENA are both set, then stereo operation applies.

REGISTER ADDRESS	BIT	LABEL	DEFAULT	DESCRIPTION
R33 (21h) DAC Digital 1	12	DAC_MONO	0	DAC Mono Mix 0 = Stereo 1 = Mono (Mono mix output on enabled DAC)

Table 33 DAC Mono Mix

### DAC DE-EMPHASIS

Digital de-emphasis can be applied to the DAC playback data (e.g. when the data comes from a CD with pre-emphasis used in the recording). De-emphasis filtering is available for sample rates of 48kHz, 44.1kHz and 32kHz. See "Digital Filter Characteristics" for details of de-emphasis filter characteristics.

REGISTER ADDRESS	BIT	LABEL	DEFAULT	DESCRIPTION
R33 (21h) DAC Digital 1	2:1	DEEMPH [1:0]	00	DAC De-Emphasis Control 00 = No de-emphasis 01 = 32kHz sample rate 10 = 44.1kHz sample rate 11 = 48kHz sample rate

Table 34 DAC De-Emphasis Control

**DAC SLOPING STOPBAND FILTER**

Two DAC filter types are available, selected by the register bit DAC\_SB\_FILT. When operating at sample rates  $\leq 24$ kHz (e.g. during voice communication) it is recommended that the sloping stopband filter type is selected (DAC\_SB\_FILT=1) to reduce out-of-band noise which can be audible at low DAC sample rates. See "Digital Filter Characteristics" for details of DAC filter characteristics.

REGISTER ADDRESS	BIT	LABEL	DEFAULT	DESCRIPTION
R33 (21h) DAC Digital 1	11	DAC_SB_FILT	0	Selects DAC filter characteristics 0 = Normal mode 1 = Sloping stopband mode (recommended when $f_s \leq 24$ kHz)

**Table 35 DAC Sloping Stopband Filter****DAC BIAS CONTROL**

The analogue circuits within the DAC use the Master bias current (see "Reference Voltages and Master Bias"). The DAC bias currents can also be reduced using the DACBIAS\_SEL and DACVMID\_SEL fields as described in Table 36. These can be used to reduce power consumption, but may have a marginal impact on audio performance in some usage modes.

The DAC bias currents can be increased using the DAC\_BIAS\_BOOST field. Setting this bit doubles the bias level of DACBIAS\_SEL and DACVMID\_BIAS\_SEL. This offers a performance improvement, but also an increase in power consumption.

Note that the increased DAC VMID buffer bias is unlikely to give better performance; when DAC\_BIAS\_BOOST is set, it is recommended to set DACVMID\_BIAS\_SEL = 01 in order to restore the Normal DAC VMID buffer bias level.

REGISTER ADDRESS	BIT	LABEL	DEFAULT	DESCRIPTION
R8 (08h) Analogue DAC 0	5	DAC_BIAS_BOOST	0	DAC Bias boost 0 = Disable 1 = Enable When DAC Bias boost is enabled, the bias selected by DACBIAS_SEL and DACVMID_BIAS_SEL are both doubled.
	4:3	DACBIAS_SEL	00	DAC bias current select 00 = Normal bias 01 = Normal bias x 0.5 10 = Normal bias x 0.66 11 = Normal bias x 0.75
	2:1	DACVMID_BIAS_SEL	00	DAC VMID buffer bias select 00 = Normal bias 01 = Normal bias x 0.5 10 = Normal bias x 0.66 11 = Normal bias x 0.75

**Table 36 DAC Bias Control**

**DAC OVERSAMPLING RATIO (OSR)**

The DAC oversampling rate is programmable to allow power consumption versus audio performance trade-offs. The default oversampling rate is low for reduced power consumption; using the higher OSR setting improves the DAC signal-to-noise performance.

REGISTER ADDRESS	BIT	LABEL	DEFAULT	DESCRIPTION
R33 (21h) DAC Digital 1	0	DAC_OSR	0	DAC Oversampling Control 0 = Low power (normal oversample) 1 = High performance (double rate)

**Table 37 DAC Oversampling Control**

## OUTPUT SIGNAL PATH

The outputs HPOUTL and LINEOUTL are derived from the Left Mixer, whilst the HPOUTR and LINEOUTR are derived from the Right Mixer. These mixers allow the stereo DAC and stereo bypass signals to be mixed together for the Headphone and Line outputs.

A feedback path for common mode noise rejection is provided at HPGND and LINEGND for the Headphone and Line outputs respectively. This pin must be connected to ground for normal operation.

The outputs LOP/LON and ROP/RON are differential line outputs derived from the Left Speaker mixer and Right Speaker mixer respectively.

Each analogue output can be separately enabled; independent volume control is also provided for each output. The output signal paths and associated control registers are illustrated in Figure 33. See "Analogue Outputs" for details of the external connections to these outputs.

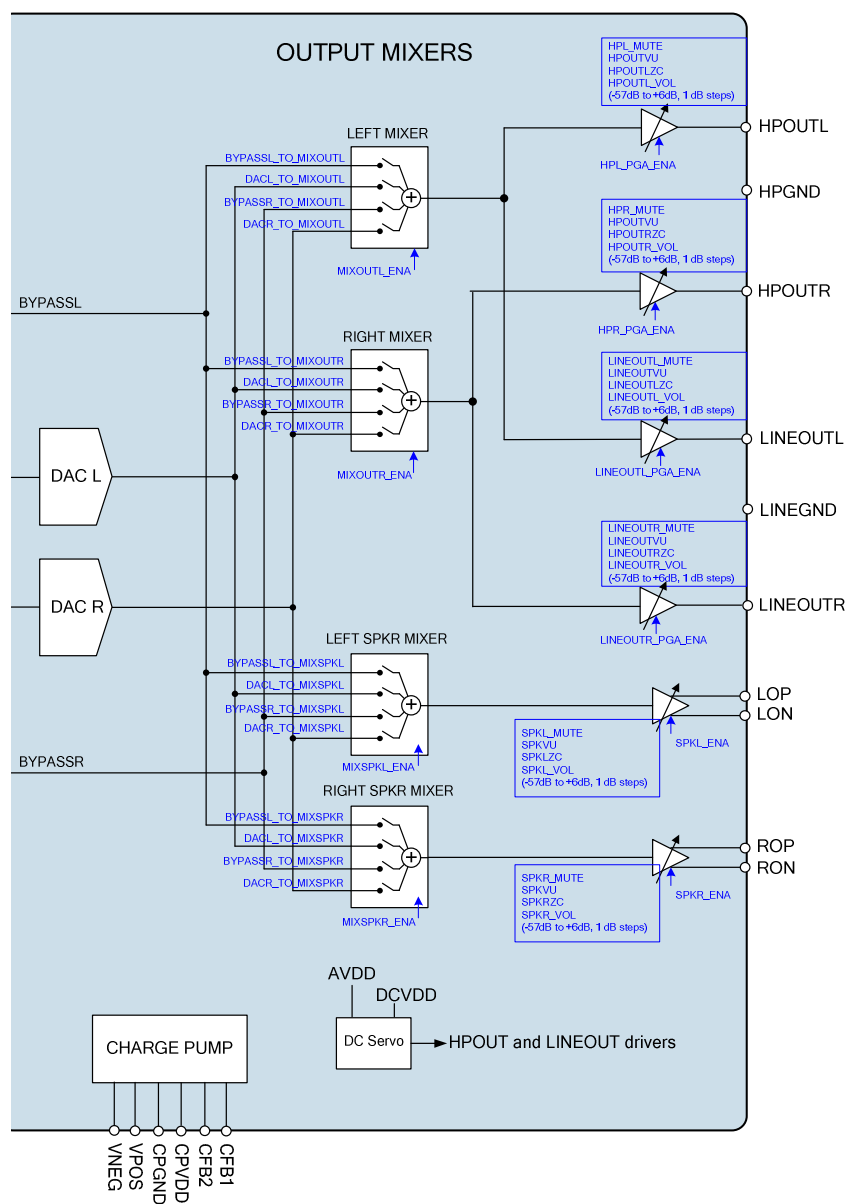


Figure 33 Output Signal Path and Control Registers

### OUTPUT SIGNAL PATHS ENABLE

The output mixers and drivers can be independently enabled and disabled using the register bits described in Table 38.

Note that the Headphone Outputs and Line Outputs are also controlled by fields located within Register R90 and R94, which provide suppression of pops & clicks when enabling and disabling these signal paths. These registers are described in the following “Headphone / Line Output Signal Paths Enable” section.

Under recommended usage conditions, the pop suppression control bits will be configured by scheduling the default Start-Up and Shut-Down sequences as described in the “Control Write Sequencer” section. In these cases, the user does not need to set the register fields in R13, R14, R15, R90 and R94 directly.

REGISTER ADDRESS	BIT	LABEL	DEFAULT	DESCRIPTION
R13 (0Dh) Power Management 1	1	MIXOUTL_ENA	0	Left Output Mixer Enable 0 = disabled 1 = enabled
	0	MIXOUTR_ENA	0	Right Output Mixer Enable 0 = disabled 1 = enabled
R14 (0Eh) Power Management 2	1	HPL_PGA_ENA	0	Left Headphone Output Enable 0 = disabled 1 = enabled
	0	HPR_PGA_ENA	0	Right Headphone Output Enable 0 = disabled 1 = enabled
R15 (0Fh) Power Management 3	1	LINEOUTL_PGA_ENA	0	Left Line Output Enable 0 = disabled 1 = enabled
	0	LINEOUTR_PGA_ENA	0	Right Line Output Enable 0 = disabled 1 = enabled
R16 (10h) Power Management 4	1	MIXSPKL_ENA	0	Left Speaker Mixer Enable 0 = disabled 1 = enabled
	0	MIXSPKR_ENA	0	Right Speaker Mixer Enable 0 = disabled 1 = enabled
R17 (11h) Power Management 5	1	SPKL_ENA	0	Left Speaker Output Enable 0 = disabled 1 = enabled
	0	SPKR_ENA	0	Right Speaker Output Enable 0 = disabled 1 = enabled

**Table 38 Output Signal Paths Enable**

To enable the output PGAs and mixers, the reference voltage VMID and the bias current must also be enabled. See “Reference Voltages and Master Bias” for details of the associated controls VMID\_RES and BIAS\_ENA.



**HEADPHONE / LINE OUTPUT SIGNAL PATHS ENABLE**

The Headphone / Line output paths can be actively discharged to AGND through internal resistors if desired. This is desirable at start-up in order to achieve a known output stage condition prior to enabling the VMID reference voltage. This is also desirable in shutdown to prevent the external connections from being affected by the internal circuits. The ground-referenced Headphone outputs and Line outputs are shorted to AGND by default; the short circuit is removed on each of these paths by setting the applicable fields HPL\_RMV\_SHORT, HPR\_RMV\_SHORT, LINEOUTL\_RMV\_SHORT or LINEOUTR\_RMV\_SHORT.

The ground-referenced Headphone output and Line output drivers are designed to suppress pops and clicks when enabled or disabled. However, it is necessary to control the drivers in accordance with a defined sequence in start-up and shut-down to achieve the pop suppression. It is also necessary to schedule the DC Servo offset correction at the appropriate point in the sequence (see "DC Servo"). Table 39 and Table 40 describe the recommended sequences for enabling and disabling these output drivers.

SEQUENCE	HEADPHONE ENABLE	LINEOUT ENABLE
Step 1	HPL_ENA = 1 HPR_ENA = 1	LINEOUTL_ENA = 1 LINEOUTR_ENA = 1
Step 2	HPL_ENA_DLY = 1 HPR_ENA_DLY = 1	LINEOUTL_ENA_DLY = 1 LINEOUTR_ENA_DLY = 1
Step 3	DC offset correction	DC offset correction
Step 4	HPL_ENA_OUTP = 1 HPR_ENA_OUTP = 1	LINEOUTL_ENA_OUTP = 1 LINEOUTR_ENA_OUTP = 1
Step 5	HPL_RMV_SHORT = 1 HPR_RMV_SHORT = 1	LINEOUTL_RMV_SHORT = 1 LINEOUTR_RMV_SHORT = 1

**Table 39 Headphone / Line Output Enable Sequence**

SEQUENCE	HEADPHONE DISABLE	LINEOUT DISABLE
Step 1	HPL_RMV_SHORT = 0 HPR_RMV_SHORT = 0	LINEOUTL_RMV_SHORT = 0 LINEOUTR_RMV_SHORT = 0
Step 2	HPL_ENA = 0 HPL_ENA_DLY = 0 HPL_ENA_OUTP = 0 HPR_ENA = 0 HPR_ENA_DLY = 0 HPR_ENA_OUTP = 0	LINEOUTL_ENA = 0 LINEOUTL_ENA_DLY = 0 LINEOUTL_ENA_OUTP = 0 LINEOUTR_ENA = 0 LINEOUTR_ENA_DLY = 0 LINEOUTR_ENA_OUTP = 0

**Table 40 Headphone / Line Output Disable Sequence**

The registers relating to Headphone / Line Output pop suppression control are defined in Table 41.

REGISTER ADDRESS	BIT	LABEL	DEFAULT	DESCRIPTION
R90 (5Ah) Analogue HP 0	7	HPL_RMV_SHORT	0	Removes HPL short 0 = HPL short enabled 1 = HPL short removed For normal operation, this bit should be set as the final step of the HPL Enable sequence.
	6	HPL_ENA_OUTP	0	Enables HPL output stage 0 = Disabled 1 = Enabled For normal operation, this bit should be set to 1 after the DC offset cancellation has been scheduled.

REGISTER ADDRESS	BIT	LABEL	DEFAULT	DESCRIPTION
	5	HPL_ENA_DLY	0	Enables HPL intermediate stage 0 = Disabled 1 = Enabled For normal operation, this bit should be set to 1 after the output signal path has been configured, and before DC offset cancellation is scheduled. This bit should be set with at least 20us delay after HPL_ENA.
	4	HPL_ENA	0	Enables HPL input stage 0 = Disabled 1 = Enabled For normal operation, this bit should be set as the first step of the HPL Enable sequence.
	3	HPR_RMV_SHORT	0	Removes HPR short 0 = HPR short enabled 1 = HPR short removed For normal operation, this bit should be set as the final step of the HPR Enable sequence.
	2	HPR_ENA_OUTP	0	Enables HPR output stage 0 = Disabled 1 = Enabled For normal operation, this bit should be set to 1 after the DC offset cancellation has been scheduled.
	1	HPR_ENA_DLY	0	Enables HPR intermediate stage 0 = Disabled 1 = Enabled For normal operation, this bit should be set to 1 after the output signal path has been configured, and before DC offset cancellation is scheduled. This bit should be set with at least 20us delay after HPR_ENA.
	0	HPR_ENA	0	Enables HPR input stage 0 = Disabled 1 = Enabled For normal operation, this bit should be set as the first step of the HPR Enable sequence.

REGISTER ADDRESS	BIT	LABEL	DEFAULT	DESCRIPTION
R94 (5Eh) Analogue Lineout 0	7	LINEOUTL_RMV_SHORT	0	Removes LINEOUTL short 0 = LINEOUTL short enabled 1 = LINEOUTL short removed For normal operation, this bit should be set as the final step of the LINEOUTL Enable sequence.
	6	LINEOUTL_ENA_OUTP	0	Enables LINEOUTL output stage 0 = Disabled 1 = Enabled For normal operation, this bit should be set to 1 after the DC offset cancellation has been scheduled.
	5	LINEOUTL_ENA_DLY	0	Enables LINEOUTL intermediate stage 0 = Disabled 1 = Enabled For normal operation, this bit should be set to 1 after the output signal path has been configured, and before DC offset cancellation is scheduled. This bit should be set with at least 20us delay after LINEOUTL_ENA.
	4	LINEOUTL_ENA	0	Enables LINEOUTL input stage 0 = Disabled 1 = Enabled For normal operation, this bit should be set as the first step of the LINEOUTL Enable sequence.
	3	LINEOUTR_RMV_SHORT	0	Removes LINEOUTR short 0 = LINEOUTR short enabled 1 = LINEOUTR short removed For normal operation, this bit should be set as the final step of the LINEOUTR Enable sequence.
	2	LINEOUTR_ENA_OUTP	0	Enables LINEOUTR output stage 0 = Disabled 1 = Enabled For normal operation, this bit should be set to 1 after the DC offset cancellation has been scheduled.
	1	LINEOUTR_ENA_DLY	0	Enables LINEOUTR intermediate stage 0 = Disabled 1 = Enabled For normal operation, this bit should be set to 1 after the output signal path has been configured, and before DC offset cancellation is scheduled. This bit should be set with at least 20us delay after LINEOUTR_ENA.
	0	LINEOUTR_ENA	0	Enables LINEOUTR input stage 0 = Disabled 1 = Enabled For normal operation, this bit should be set as the first step of the LINEOUTR Enable sequence.

Table 41 Headphone / Line Output Pop Suppression Control

**OUTPUT PGA BIAS CONTROL**

The output PGA circuits use the Master bias current (see “Reference Voltages and Master Bias”). The output PGA bias currents can also be controlled using the PGA\_BIAS field as described in Table 42. Selecting a lower bias can be used to reduce power consumption, but may have a marginal impact on audio performance in some usage modes. Selecting a higher bias offers a performance improvement, but also an increase in power consumption.

REGISTER ADDRESS	BIT	LABEL	DEFAULT	DESCRIPTION
R172 (ACh) Analogue Output Bias 0	6:4	PGA_BIAS [2:0]	000	Headphone and Lineout PGA bias control 000 = Normal bias 001 = Normal bias x 1.5 010 = Normal bias x 0.75 011 = Normal bias x 0.5 100 = Normal bias x 0.33 101 = Normal bias 110 = Normal bias 111 = Normal bias x 2

**Table 42 Output PGA Bias Control****OUTPUT DRIVERS BIAS CONTROL**

The bias of the Headphone and Lineout drivers can be controlled independently of the PGA bias. These may be increased or decreased using the OUTPUTS\_BIAS field as described in Table 43. This can be used to reduce power consumption or improve performance.

If it is desired to improve the performance of the outputs with the minimum increase in power consumption, then it is recommended to increase the OUTPUTS\_BIAS level and to use the default setting of PGA\_BIAS.

REGISTER ADDRESS	BIT	LABEL	DEFAULT	DESCRIPTION
R187 (BBh) Analogue Output Bias 2	2:0	OUTPUTS_BIAS [2:0]	000	Headphone and Lineout Output Drivers bias control 000 = Normal bias 001 = Normal bias x 1.5 010 = Normal bias x 0.75 011 = Normal bias x 0.5 100 = Normal bias x 0.33 101 = Normal bias 110 = Normal bias 111 = Normal bias x 2

**Table 43 Output Drivers Bias Control**

**OUTPUT MIXER CONTROL**

Each of the four output mixers has the same four inputs:

- DAC Left
- DAC Right
- Bypass Left
- Bypass Right

The input signals to the left and right mixers (feeding HPOUTL/R and LINEOUTL/R) are enabled using the register fields described in Table 44. These mixers do not provide volume controls on the inputs or outputs. However, input signals can be attenuated at source using the control fields LIN\_VOL, RIN\_VOL, DACL\_VOL and DACR\_VOL.

REGISTER ADDRESS	BIT	LABEL	DEFAULT	DESCRIPTION
R50 (32h) Analogue Left Mix 0	3	DACL_TO_MIXO UTL	1	Left DAC to Left Output Mixer Enable 0 = disabled 1 = enabled
	2	DACR_TO_MIXO UTL	0	Right DAC to Left Output Mixer Enable 0 = disabled 1 = enabled
	1	BYPASSL_TO_MI XOUTL	0	Left Analogue Input to Left Output Mixer Enable 0 = disabled 1 = enabled
	0	BYPASSR_TO_M IXOUTL	0	Right Analogue Input to Left Output Mixer Enable 0 = disabled 1 = enabled
R51 (33h) Analogue Right Mix 0	3	DACL_TO_MIXO UTR	0	Left DAC to Right Output Mixer Enable 0 = disabled 1 = enabled
	2	DACR_TO_MIXO UTR	1	Right DAC to Right Output Mixer Enable 0 = disabled 1 = enabled
	1	BYPASSL_TO_MI XOUTR	0	Left Analogue Input to Right Output Mixer Enable 0 = disabled 1 = enabled
	0	BYPASSR_TO_M IXOUTR	0	Right Analogue Input to Right Output Mixer Enable 0 = disabled 1 = enabled

**Table 44 Headphone and Line Output Mixer Control**

The input signals to the speaker mixers are enabled and controlled using the register fields described in Table 45.

These mixers provide a selectable 0dB or -6dB volume control on each input. The input signals may also be controlled at source using the control fields LIN\_VOL, RIN\_VOL, DACL\_VOL and DACR\_VOL, but it should be noted that adjusting these fields would also affect the other output mixers.

REGISTER ADDRESS	BIT	LABEL	DEFAULT	DESCRIPTION
R52 (34h) Analogue Spk Mix Left 0	3	DACL_TO_MIXSPKL	0	Left DAC to Left Spkr Mixer Enable 0 = disabled 1 = enabled
	2	DACR_TO_MIXSPKL	0	Right DAC to Left Spkr Mixer Enable 0 = disabled 1 = enabled
	1	BYPASSL_TO_MIXSPKL	0	Left Analogue Input to Left Spkr Mixer Enable 0 = disabled 1 = enabled
	0	BYPASSR_TO_MIXSPKL	0	Right Analogue Input to Left Spkr Mixer Enable 0 = disabled 1 = enabled
R53 (35h) Analogue Spk Mix Left 1	3	DACL_MIXSPKL_VOL	0	Left DAC to Left Spkr Mixer volume control 0 = 0dB 1 = -6dB
	2	DACR_MIXSPKL_VOL	0	Right DAC to Left Spkr Mixer volume control 0 = 0dB 1 = -6dB
	1	BYPASSL_MIXSPKL_VOL	0	Left Analogue Input to Left Spkr Mixer volume control 0 = 0dB 1 = -6dB
	0	BYPASSR_MIXSPKL_VOL	0	Right Analogue Input to Left Spkr Mixer volume control 0 = 0dB 1 = -6dB
R54 (36h) Analogue Spk Mix Right 0	3	DACL_TO_MIXSPKR	0	Left DAC to Right Spkr Mixer Enable 0 = disabled 1 = enabled
	2	DACR_TO_MIXSPKR	0	Right DAC to Right Spkr Mixer Enable 0 = disabled 1 = enabled
	1	BYPASSL_TO_MIXSPKR	0	Left Analogue Input to Right Spkr Mixer Enable 0 = disabled 1 = enabled
	0	BYPASSR_TO_MIXSPKR	0	Right Analogue Input to Right Spkr Mixer Enable 0 = disabled 1 = enabled

REGISTER ADDRESS	BIT	LABEL	DEFAULT	DESCRIPTION
R55 (37h) Analogue Spk Mix Right 1	3	DACL_MIXSPKR_VOL	0	Left DAC to Right Spkr Mixer volume control 0 = 0dB 1 = -6dB
	2	DACR_MIXSPKR_VOL	0	Right DAC to Right Spkr Mixer volume control 0 = 0dB 1 = -6dB
	1	BYPASSL_MIXSPKR_VOL	0	Left Analogue Input to Right Spkr Mixer volume control 0 = 0dB 1 = -6dB
	0	BYPASSR_MIXSPKR_VOL	0	Right Analogue Input to Right Spkr Mixer volume control 0 = 0dB 1 = -6dB

Table 45 Speaker Mixer Control

### OUTPUT VOLUME CONTROL

Each analogue output can be independently controlled. The headphone output control fields are described in Table 46. The line output control fields are described in Table 47. The differential line output control fields are described in Table 48. The output pins are described in more detail in "Analogue Outputs".

The volume and mute status of each output can be controlled individually using the bit fields shown in Table 46, Table 47 and Table 48.

To prevent "zipper noise" when a volume adjustment is made, a zero-cross function is provided on all output paths. When this function is enabled, volume updates will not take place until a zero-crossing is detected. In the event of a long period without zero-crossings, a timeout will apply. The timeout must be enabled by setting the TO\_ENA bit, as defined in "Clocking and Sample Rates".

The volume update bits control the loading of the output driver volume data. For example, when HPOUTVU is set to 0, the headphone volume data can be loaded into the respective control register, but will not actually change the gain setting. The Left and Right headphone volume settings are updated when a 1 is written to HPOUTVU. This makes it possible to update the gain of a Left/Right pair of output paths simultaneously.

REGISTER ADDRESS	BIT	LABEL	DEFAULT	DESCRIPTION
R57 (39h) Analogue OUT1 Left	8	HPL_MUTE	0	Left Headphone Output Mute 0 = Un-mute 1 = Mute
	7	HPOUTVU	0	Headphone Output Volume Update Writing a 1 to this bit will update HPOUTL and HPOUTR volumes simultaneously.
	6	HPOUTLZC	0	Left Headphone Output Zero Cross Enable 0 = disabled 1 = enabled
	5:0	HPOUTL_VOL [5:0]	10_1101	Left Headphone Output Volume 000000 = -57dB 000001 = -56dB (... 1dB steps) 111001 = 0dB (... 1dB steps) 111110 = +5dB 111111 = +6dB
R58 (3Ah) Analogue OUT1 Right	8	HPR_MUTE	0	Right Headphone Output Mute 0 = Un-mute 1 = Mute
	7	HPOUTVU	0	Headphone Output Volume Update Writing a 1 to this bit will update HPOUTL and HPOUTR volumes simultaneously.
	6	HPOUTRZC	0	Right Headphone Output Zero Cross Enable 0 = disabled 1 = enabled
	5:0	HPOUTR_VOL [5:0]	10_1101	Right Headphone Output Volume 000000 = -57dB 000001 = -56dB (... 1dB steps) 111001 = 0dB (... 1dB steps) 111110 = +5dB 111111 = +6dB

Table 46 Volume Control for HPOUTL and HPOUTR



REGISTER ADDRESS	BIT	LABEL	DEFAULT	DESCRIPTION
R59 (3Bh) Analogue OUT2 Left	8	LINEOUTL_MUTE	0	Left Line Output Mute 0 = Un-mute 1 = Mute
	7	LINEOUTVU	0	Line Output Volume Update Writing a 1 to this bit will update LINEOUTL and LINEOUTR volumes simultaneously.
	6	LINEOUTLZC	0	Left Line Output Zero Cross Enable 0 = disabled 1 = enabled
	5:0	LINEOUTL_VOL [5:0]	11_1001	Left Line Output Volume 000000 = -57dB 000001 = -56dB (... 1dB steps) 111001 = 0dB (... 1dB steps) 111110 = +5dB 111111 = +6dB
R60 (3Ch) Analogue OUT2 Right	8	LINEOUTR_MUTE	0	Right Line Output Mute 0 = Un-mute 1 = Mute
	7	LINEOUTVU	0	Line Output Volume Update Writing a 1 to this bit will update LINEOUTL and LINEOUTR volumes simultaneously.
	6	LINEOUTRZC	0	Right Line Output Zero Cross Enable 0 = disabled 1 = enabled
	5:0	LINEOUTR_VOL [5:0]	11_1001	Right Line Output Volume 000000 = -57dB 000001 = -56dB (... 1dB steps) 111001 = 0dB (... 1dB steps) 111110 = +5dB 111111 = +6dB

Table 47 Volume Control for LINEOUTL and LINEOUTR

REGISTER ADDRESS	BIT	LABEL	DEFAULT	DESCRIPTION
R62 (3Eh) Analogue OUT3 Left	8	SPKL_MUTE	1	Left Speaker Output Mute 0 = Un-mute 1 = Mute
	7	SPKVU	0	Speaker Output Volume Update Writing a 1 to this bit will update LON/LOP and RON/ROP volumes simultaneously.
	6	SPKLZC	0	Left Speaker Output Zero Cross Enable 0 = disabled 1 = enabled
	5:0	SPKL_VOL [5:0]	11_1001	Left Speaker Output Volume 000000 = -57dB 000001 = -56dB (... 1dB steps) 111001 = 0dB (... 1dB steps) 111110 = +5dB 111111 = +6dB
R63 (3Fh) Analogue OUT3 Right	8	SPKR_MUTE	1	Right Speaker Output Mute 0 = Un-mute 1 = Mute
	7	SPKVU	0	Speaker Output Volume Update Writing a 1 to this bit will update LON/LOP and RON/ROP volumes simultaneously.
	6	SPKRZC	0	Right Speaker Output Zero Cross Enable 0 = disabled 1 = enabled
	5:0	SPKR_VOL [5:0]	11_1001	Right Speaker Output Volume 000000 = -57dB 000001 = -56dB (... 1dB steps) 111001 = 0dB (... 1dB steps) 111110 = +5dB 111111 = +6dB

Table 48 Volume Control for LON/LOP and RON/ROP

## ANALOGUE OUTPUTS

The WM8903 has eight analogue output pins:

- Headphone outputs, HPOUTL and HPOUTR
- Line outputs, LINEOUTL and LINEOUTR
- Differential line outputs, LON/LOP and RON/ROP

The output signal paths and associated control registers are illustrated in Figure 33.

### HEADPHONE OUTPUTS – HPOUTL AND HPOUTR

The headphone outputs are designed to drive 16Ω or 32Ω headphones. These outputs are ground-referenced, i.e. no series capacitor is required between the pins and the headphone load. They are powered by an on-chip charge pump (see “Charge Pump” section). Signal volume at the headphone outputs is controlled as shown in Table 46.

The ground-referenced outputs incorporates a common mode, or ground loop, feedback path which provides rejection of system-related ground noise. The return path for the HPOUTL and HPOUTR outputs is via HPGND. This pin must be connected to ground for normal operation of the headphone output. No register configuration is required.

### LINE OUTPUTS – LINEOUTL AND LINEOUTR

The line outputs are identical to the headphone outputs in design. They are ground-referenced and power by the on-chip charge pump. Signal volume at the headphone outputs is controlled as shown in Table 47.

Note that these outputs are intended for driving line loads, as the charge pump powering both the Headphone and Line outputs can only provide sufficient power to drive one set of headphones at any given time.

The ground-referenced outputs incorporates a common mode, or ground loop, feedback path which provides rejection of system-related ground noise. The return path for the LINEOUTL and LINEOUTR outputs is via LINEGND. This pin must be connected to ground for normal operation of the line output. No register configuration is required.

### DIFFERENTIAL LINE OUTPUTS – LON/LOP AND RON/ROP

The differential line outputs are designed to differential line loads, including external loudspeaker drivers. The WM9001 is an ideal component for driving loudspeakers from these outputs. These pins are referenced to VMID (AVDD/2) and are powered directly from the AVDD supply.

Signal volume at the differential line outputs is controlled as shown in Table 48.

### EXTERNAL COMPONENTS FOR GROUND-REFERENCED OUTPUTS

In the case of the ground referenced outputs HPOUTL, HPOUTR, LINEOUTL and LINEOUTR, it is recommended to connect a zobel network to the audio output pins for best audio performance in all applications. The components of the zobel network have the effect of dampening high frequency oscillations or instabilities that can arise outside the audio band under certain conditions. Possible sources of these instabilities include the inductive load of a headphone coil or an active load in the form of an external line amplifier. The capacitance of lengthy cables or PCB tracks can also lead to amplifier instability. The zobel network should comprise a  $20\Omega$  resistor and  $100\text{nF}$  capacitor in series with each other, as illustrated in Figure 34.

Note that the zobel network is recommended for best audio quality and amplifier stability in all cases.

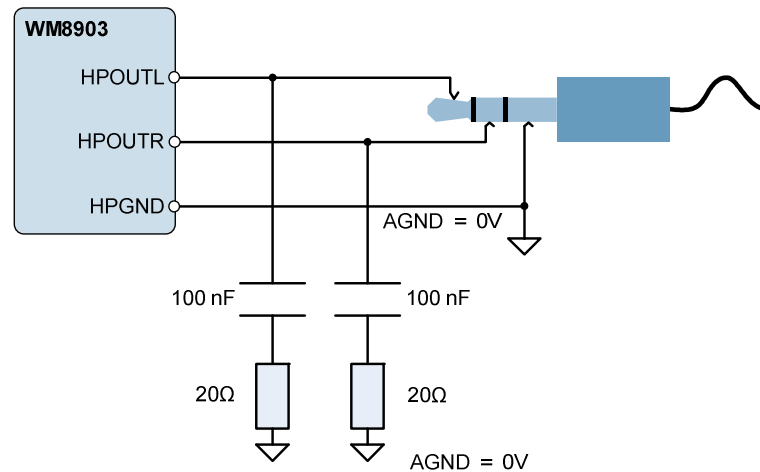


Figure 34 Zobel Network Components for HPOUTL, HPOUTR, LINEOUTL and LINEOUTR

The differential line outputs LOP/LON and ROP/RON would, typically, be connected to differential line drivers such as the WM9001 speaker driver. In such applications, a zobel network is not required on these differential line outputs.

## REFERENCE VOLTAGES AND MASTER BIAS

This section describes the analogue reference voltage and bias current controls. It also describes the VMID soft-start circuit for pop-free start-up and shut-down. Note that, under the recommended usage conditions of the WM8903, these features will be configured by running the default Start-Up and Shut-Down sequences as described in the “Control Write Sequencer” section. In these cases, the user does not need to set these register fields directly.

The analogue circuits in the WM8903 require a mid-rail analogue reference voltage, VMID. This reference is generated from AVDD via a programmable resistor chain. Together with the external VMID decoupling capacitor, the programmable resistor chain results in a slow, normal or fast charging characteristic on VMID. This is controlled by VMID\_RES [1:0], and can be used to optimise the reference for normal operation, low power standby or for fast start-up as described in Table 49. For normal operation, the VMID\_RES field should be set to 01.

The analogue circuits in the WM8903 require a bias current. The normal bias current is enabled by setting BIAS\_ENA. Note that the normal bias current source requires VMID to be enabled also. The normal bias current can also be controlled using the ISEL field as described in Table 49. This can be used to reduce power consumption, but may have a detrimental impact on audio performance in some usage modes. The default setting is recommended.

Note that the DAC and Output PGA bias circuits may also be adjusted in order to reduce power consumption. For details, see “Digital-to-Analogue Converter (DAC)” or “Output Signal Path”.

An alternate bias current source (Start-Up Bias) is provided for pop-free start-up; this is selected using POBCTRL (see Table 50). Note that the default setting of POBCTRL selects the Start-Up Bias. The normal bias is only selected when POBCTRL is set to logic 0.

REGISTER ADDRESS	BIT	LABEL	DEFAULT	DESCRIPTION
R4 (04h) Bias Control 0	3:2	ISEL [1:0]	10	Master Bias control 00 = Normal bias x 0.5 01 = Normal bias x 0.75 10 = Normal bias 11 = Normal bias x 1.5
	0	BIAS_ENA	0	Enables the Normal bias current generator (for all analogue functions) 0 = Disabled 1 = Enabled
R5 (05h) VMID Control 0	2:1	VMID_RES [1:0]	00	VMID Divider Enable and Select 00 = VMID disabled (for OFF mode) 01 = 2 x 50kΩ divider (for normal operation) 10 = 2 x 250kΩ divider (for low power standby) 11 = 2 x 5kΩ divider (for fast start-up)

Table 49 Reference Voltages and Master Bias Enable

A pop-suppressed start-up requires VMID to be enabled smoothly, without the step change normally associated with the initial stage of the VMID capacitor charging. A pop-suppressed start-up also requires the analogue bias current to be enabled throughout the signal path prior to the VMID reference voltage being applied. The WM8903 incorporates pop-suppression circuits which address these requirements.

The alternate current source (Start-Up Bias) is enabled by STARTUP\_BIAS\_ENA. The start-up bias is selected (in place of the normal bias) by POBCTRL. It is recommended that the start-up bias is used during start-up, before switching back to the higher quality, normal bias.

VMID\_IO\_ENA has the same functionality as STARTUP\_BIAS\_ENA. The start-up bias is enabled by setting either of these bits.

A soft-start circuit is provided in order to control the switch-on of the VMID reference. The soft-start control circuit is enabled by setting VMID\_SOFT. Three slew rates are provided, under control of the VMID\_SOFT field. When the soft-start circuit is enabled prior to enabling VMID\_RES, the reference voltage rises smoothly, without the step change that would otherwise occur. It is recommended that the soft-start circuit and the output signal path be enabled before VMID is enabled by VMID\_RES.

A soft shut-down is provided, using the soft-start control circuit and the start-up bias current generator. The soft shut-down of VMID is achieved by setting VMID\_SOFT, STARTUP\_BIAS\_ENA and POBCTRL to select the start-up bias current and soft-start circuit prior to setting VMID\_RES=00.

REGISTER ADDRESS	BIT	LABEL	DEFAULT	DESCRIPTION
R4 (04h) Bias Control 0	4	POBCTRL	1	Selects the bias current source 0 = Normal bias 1 = Start-Up bias
	1	STARTUP_BIAS_ENA	0	Enables the Start-Up bias current generator 0 = Disabled 1 = Enabled
R5 (05h) VMID Control 0	5	VMID_IO_ENA	0	Enables the Start-Up bias current generator 0 = Disabled 1 = Enabled (same functionality as STARTUP_BIAS_ENA)
	4:3	VMID_SOFT [1:0]	10	VMID soft start enable / slew rate control 00 = Disabled 01 = Fast soft start 10 = Nominal soft start 11 = Slow soft start

**Table 50 Soft Start Control**

## POP SUPPRESSION CONTROL

The WM8903 incorporates Wolfson's SilentSwitch™ technology which enables pops normally associated with Start-Up, Shut-Down or signal path control to be suppressed. To achieve maximum benefit from these features, careful attention is required to the sequence and timing of these controls. Note that, under the recommended usage conditions of the WM8903, these features will be configured by running the default Start-Up and Shut-Down sequences as described in the "Control Write Sequencer" section. In these cases, the user does not need to set these register fields directly.

The Pop Suppression controls relating to the Headphone / Line Output drivers are described in the "Output Signal Path" section.

## DISABLED INPUT / OUTPUT CONTROL

The analogue inputs to the WM8903 and the Differential Line (Speaker) outputs are biased to VMID in normal operation. In order to avoid audible pops caused by a disabled signal path dropping to AGND, the WM8903 can maintain these connections at VMID when the relevant input or output stage is disabled. This is achieved by connecting a buffered VMID reference to the input or output. The buffered VMID reference is enabled by setting VMID\_BUF\_ENA.

When the buffered VMID reference is enabled, it is connected to any unused input pins by setting the BUFIO\_ENA register bit. When buffered VMID is enabled, it is connected to any disabled Differential Line outputs (speaker driver outputs) by setting VMID\_TIE\_ENA. The resistance associated with VMID\_TIE\_ENA can be either 500Ω or 20kΩ, depending on the VROI register bit.

REGISTER ADDRESS	BIT	LABEL	DEFAULT	DESCRIPTION
R5 (05h) VMID Control 0	7	VMID_TIE_ENA	0	VMID buffer to Differential Lineouts 0 = Disabled 1 = Enabled (only applies when relevant outputs are disabled, ie. SPLK=0 or SPKR=0. Resistance is controlled by VROI.)
	6	BUFIO_ENA	0	VMID buffer to unused Inputs/Outputs 0 = Disabled 1 = Enabled
	0	VMID_BUF_ENA	0	VMID Buffer Enable 0 = Disabled 1 = Enabled
R65 (41h)	0	VROI	0	Select VMID_TIE_ENA resistance for disabled Differential Lineouts 0 = 20k ohm 1 = 500 ohm

Table 51 Disabled Input / Output Control

## DIFFERENTIAL LINE OUTPUT DISCHARGE CONTROL

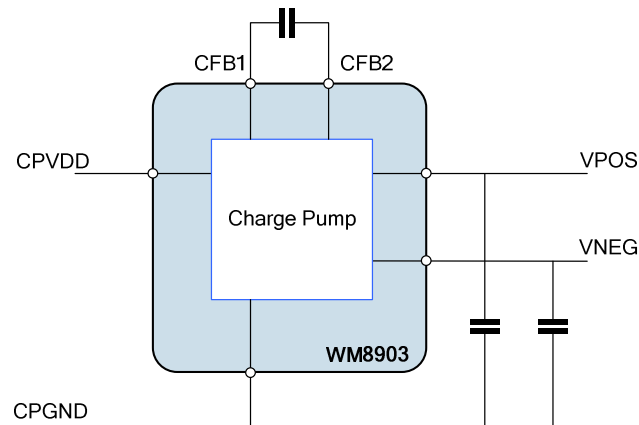
The differential line output paths can be actively discharged to AGND through internal resistors if desired. This is desirable at start-up in order to achieve a known output stage condition prior to enabling the soft-start VMID reference voltage. This is also desirable in shut-down to prevent the external connections from being affected by the internal circuits. The Differential Line outputs (speaker driver outputs) can be discharged to AGND by setting SPK\_DISCHARGE.

REGISTER ADDRESS	BIT	LABEL	DEFAULT	DESCRIPTION
R65 (41h)	1	SPK_DISCHARGE	0	Speaker Discharge Enable 0 = Disabled 1 = Enable

Table 52 Differential Line Output Discharge Control

## CHARGE PUMP

The WM8903 incorporates a dual-mode Charge Pump which generates the supply rails for the headphone and line output drivers, HPOUTL, HPOUTR, and LINEOUTL and LINEOUTR. The Charge Pump has a single supply input, CPVDD, and generates split rails VPOS and VNEG according to the selected mode of operation. The Charge Pump connections are illustrated in Figure 35 (see the “Electrical Characteristics” section for external component values). An input decoupling capacitor may also be required at CPVDD, depending upon the system configuration.



**Figure 35 Charge Pump External Connections**

The Charge Pump is enabled by setting the CP\_ENA bit. When enabled, the charge pump adjusts the output voltages (VPOS and VNEG) as well as the switching frequency in order to optimise the power consumption according to the operating conditions. This can take two forms, which are selected using the CP\_DYN\_PWR register bit.

- Register control (CP\_DYN\_PWR = 0)
- Dynamic control (CP\_DYN\_PWR = 1)

Under Register control, the HPOUTL\_VOL, HPOUTR\_VOL, LINEOUTL\_VOL and LINEOUTR\_VOL register settings are used to control the charge pump mode of operation.

Under Dynamic control, the audio signal level in the DAC is used to control the charge pump mode of operation. This is the Wolfson ‘Class W’ mode, which allows the power consumption to be optimised in real time, but can only be used if the DAC is the only signal source. This mode should not be used if any of the bypass paths are used to mix analogue inputs into the output signal path.

Under the recommended usage conditions of the WM8903, the Charge Pump will be enabled by running the default Start-Up sequence as described in the “Control Write Sequencer” section. (Similarly, it will be disabled by running the Shut-Down sequence.) In these cases, the user does not need to write to the CP\_ENA bit. The Charge Pump operating mode defaults to Register control; Dynamic control may be selected by setting the CP\_DYN\_PWR register bit, if appropriate.

When digital sidetone is used (see “Digital Mixing”), it is recommended that the Charge Pump operates in Register Control mode only (CP\_DYN\_PWR = 0). This is because the Dynamic Control mode (Class W) does not measure the sidetone signal level and hence the Charge Pump configuration cannot be optimised for all signal conditions when digital sidetone is enabled; this could lead to signal clipping.

The MCLK signal must be present for the charge pump to function. The clock division from MCLK is handled transparently by the WM8903 without user intervention, as long as MCLK and sample rates are set correctly (see “Clocking and Sample Rates” section). The clock divider ratio depends on the SAMPLE\_RATE [3:0], CLK\_SYS\_MODE [1:0], and CLK\_SYS\_RATE [3:0] register settings.

The charge pump requires a minimum CLK\_SYS frequency of 2.8224MHz.



The Charge Pump control fields are described in Table 53.

REGISTER ADDRESS	BIT	LABEL	DEFAULT	DESCRIPTION
R98 (62h) Charge Pump 0	0	CP_ENA	0	Enable charge-pump digits 0 = disable 1 = enable
R104 (68h) Class W 0	0	CP_DYN_PWR	0	Enable dynamic charge pump power control 0 = charge pump controlled by volume register settings 1 = charge pump controlled by real- time audio level

**Table 53 Charge Pump Control**

## DC SERVO

The WM8903 provides a DC servo circuit on the headphone and line outputs in order to remove DC offset from these ground-referenced outputs. When enabled, the DC servo ensures that the DC level of these outputs remains within 1.5mV of ground. Removal of the DC offset is important because any deviation from GND at the output pin will cause current to flow through the load under quiescent conditions, resulting in increased power consumption. Additionally, the presence of DC offsets can result in audible pops and clicks at power up and power down.

The recommended usage of the DC Servo is initialised by running the default Start-Up sequence as described in the “Control Write Sequencer” section. The default Start-Up sequence selects START\_STOP servo mode, which causes a one-off correction to be performed, after which the measured DC offset is then maintained on the headphone and line outputs.

If a different usage is required, e.g. if one or more of the outputs is not in use, or if periodic DC offset correction is required, then the default Start-Up sequence may be modified according to specific requirements. The relevant control fields are defined in Table 54 .

If DC offset correction is not required on any output, then DCS\_MASTER\_ENA should be set to 0. Setting this field to 0 before running the Start-Up sequence will disable the DC Servo on all outputs.

If DC offset correction is only required on selected channels, then DCS\_ENA should be set accordingly. Setting this field to 1111b enables the DC Servo on all outputs. Setting any bit to 0 disables the DC Servo on the corresponding output. Disabling the DC Servo on unused outputs reduces power consumption in the device. To modify this within the Start-Up sequence, the data in WSEQ Address 23 and WSEQ Address 24 should be updated (see “Control Write Sequencer”) before running the sequence.

If periodic updates to the DC offset correction is required, then DCS\_MODE should be modified. Setting this field to 11b selects START\_UPDATE servo mode, which causes the DC offset to be measured and corrected on a periodic basis. The default time between updates is approximately 10 minutes. Scheduling periodic updates enables the WM8903 to compensate for any change in DC offsets which might have occurred due to power supply drift or other factors. To modify this within the Start-Up sequence, the data in WSEQ Address 22 should be updated (see “Control Write Sequencer”) before running the sequence.

REGISTER ADDRESS	BIT	LABEL	DEFAULT	DESCRIPTION
R67 (43h) DC Servo 0	4	DCS_MASTER_EN A	1	DC Servo Master Control 0 = DC Servo Reset 1 = DC Servo Enabled
	3:0	DCS_ENA [3:0]	0000	DC Servo Enable [3] - HPOUTL enable [2] - HPOUTR enable [1] - LOUTL enable [0] - LOUTR enable
R69 (45h) DC Servo 2	1:0	DCS_MODE [1:0]	00	DC Servo Mode 00 = WRITE_STOP 01 = WRITE_UPDATE 10 = START_STOP 11 = START_UPDATE

**Table 54 DC Servo Control**

To reduce power consumption when unused audio outputs are disabled, the DC Servo correction should also be disabled. The WM8903 provides the capability to quickly resume the necessary DC Servo correction when the outputs are re-enabled, without the time delay associated with the START\_STOP mode of DC Servo operation.

If the DC Servo correction is disabled using the DCS\_ENA bits, but the DCS\_MASTER\_ENA bit is maintained at 1, then the DC Servo will retain the latest correction values in its memory. These values will be re-applied when the DC Servo is later enabled via the DCS\_ENA bits.

An alternative method to apply known correction settings is to read the correction values from the WM8903 register map and to store these for later use. After DC offset correction has been performed, the applicable correction values can be read from the fields in the Servo Readback registers R81 to R84 described in Table 55.

Setting DCS\_MODE to 00b or 01b selects WRITE\_STOP mode and WRITE\_UPDATE mode respectively. WRITE\_STOP mode is similar to START\_STOP mode, except that the DC Servo correction factors are read from internal registers, instead of being calculated from the measured output conditions. In the same way, WRITE\_UPDATE mode is similar to START\_UPDATE mode. When the DC Servo is commanded to one of these modes, the initial DC offset correction values are read from the \_WRITE\_VAL field in registers R71 to R74 described in Table 55.

Selecting WRITE\_STOP or WRITE\_UPDATE mode applies initial settings which should be written to registers R71 to R74 before the DC Servo is enabled. In WRITE\_STOP mode, no further DC correction is applied. In WRITE\_UPDATE mode, the DC Servo will periodically measure and adjust the DC offset correction. Similar to START\_UPDATE mode, the default time between updates is approximately 10 minutes.

REGISTER ADDRESS	BIT	LABEL	DEFAULT	DESCRIPTION
R71 (47h) DC Servo 4	7:0	DCS_HPOUTL_WRITE_VAL [7:0]	0000_0000	Value to send to Left Headphone Output Servo in a WRITE mode Two's complement format. LSB is 0.25mV. Range is +/-32mV
R72 (48h) DC Servo 5	7:0	DCS_HPOUTR_WRITE_VAL [7:0]	0000_0000	Value to send to Right Headphone Output Servo in a WRITE mode Two's complement format. LSB is 0.25mV. Range is +/-32mV
R73 (49h) DC Servo 6	7:0	DCS_LOUTL_WRITE_VAL [7:0]	0000_0000	Value to send to Left Line Output Servo in a WRITE mode Two's complement format. LSB is 0.25mV. Range is +/-32mV
R74 (4Ah) DC Servo 7	7:0	DCS_LOUTR_WRITE_VAL [7:0]	0000_0000	Value to send to Right Line Output Servo in a WRITE mode Two's complement format. LSB is 0.25mV. Range is +/-32mV
R81 (51h) DC Servo Readback 1	7:0	DCS_HPOUTL_INTEG [7:0]	0000_0000	Readback value on Left Headphone Output Servo. Two's complement format. LSB is 0.25mV. Range is +/-32mV
R82 (52h) DC Servo Readback 2	7:0	DCS_HPOUTR_INTEG [7:0]	0000_0000	Readback value on Headphone Right Output Servo. Two's complement format. LSB is 0.25mV. Range is +/-32mV
R83 (53h) DC Servo Readback 3	7:0	DCS_LOUTL_INTEG [7:0]	0000_0000	Readback value on Left Line Output Servo. Two's complement format. LSB is 0.25mV. Range is +/-32mV
R84 (54h) DC Servo Readback 4	7:0	DCS_LOUTR_INTEG [7:0]	0000_0000	Readback value on Right Line Output Servo. Two's complement format. LSB is 0.25mV. Range is +/-32mV

Table 55 DC Servo Initial Settings and Readback

## DIGITAL AUDIO INTERFACE

The digital audio interface is used for inputting DAC data into the WM8903 and outputting ADC data from it. The digital audio interface uses four pins:

- ADCDAT: ADC data output
- DACDAT: DAC data input
- LRC: DAC and ADC data alignment clock
- BCLK: Bit clock, for synchronisation

The clock signals BCLK and LRCLK can be outputs when the WM8903 operates as a master, or inputs when it is a slave (see “Master And Slave Mode Operation” below).

Note that the BCLK pin can also support other functions, as described under “General Purpose Input/Output (GPIO)”. BCLK is the default function on this pin (GP5\_FN = 1h). Under default conditions, the other GPIO control fields for this pin have no effect.

Four different audio data formats are supported:

- Left justified
- Right justified
- I2S
- DSP mode

All four of these modes are MSB first. They are described in “Audio Data Formats (Normal Mode)” below. Refer to the “Signal Timing Requirements” section for timing information.

Time Division Multiplexing (TDM) is available in all four data format modes. The WM8903 can be programmed to send and receive data in one of two time slots.

PCM operation is supported using the DSP mode.

### MASTER AND SLAVE MODE OPERATION

The WM8903 digital audio interface can operate in master or slave mode, as shown in Figure 36 and Figure 37.

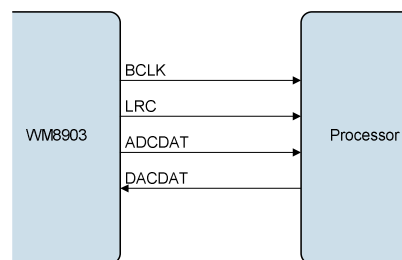


Figure 36 Master Mode

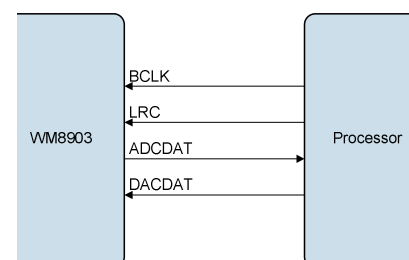


Figure 37 Slave Mode

In master mode, BCLK is derived from CLK\_SYS via a programmable division set by BCLK\_DIV.

In master mode, LRC is derived from BCLK via a programmable division set by LRCLK\_RATE. The BCLK input to this divider may be internal or external, allowing mixed master and slave modes.

The direction of these signals and the clock frequencies are controlled as described in the “Digital Audio Interface Control” section.

BCLK and LRC can be enabled as outputs in Slave mode, allowing mixed Master/Slave operation - see “Digital Audio Interface Control”.

**OPERATION WITH TDM**

Time division multiplexing (TDM) allows multiple devices to transfer data simultaneously on the same bus. The WM8903 ADCs and DACs support TDM in master and slave modes for all data formats and word lengths. TDM is enabled and configured using register bits defined in the “Digital Audio Interface Control” section.

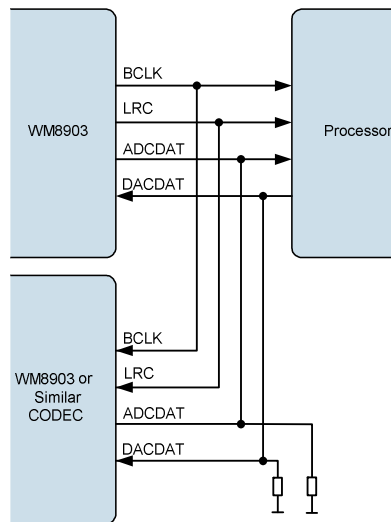


Figure 38 TDM with WM8903 as Master

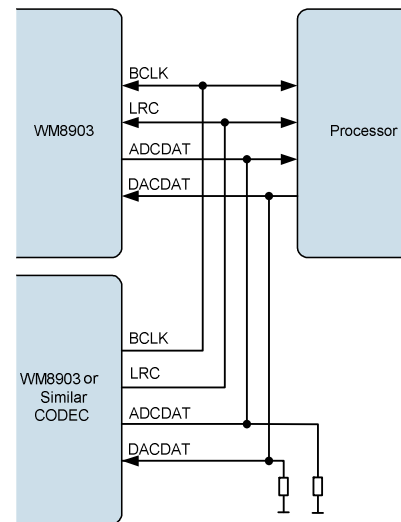


Figure 39 TDM with Other CODEC as Master

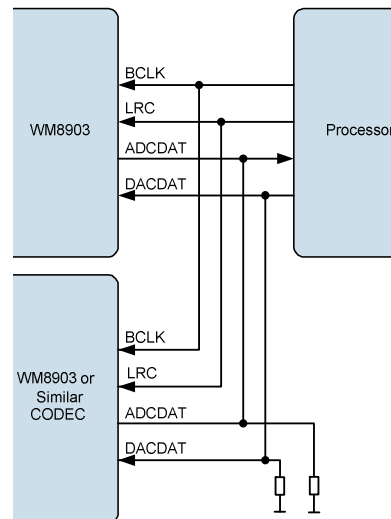


Figure 40 TDM with Processor as Master

**Note:** The WM8903 is a 24-bit device. If the user operates the WM8903 in 32-bit mode then the 8 LSBs will be ignored on the receiving side and not driven on the transmitting side. It is therefore recommended to add a pull-down resistor if necessary to the DACDAT line and the ADCCDAT line in TDM mode.

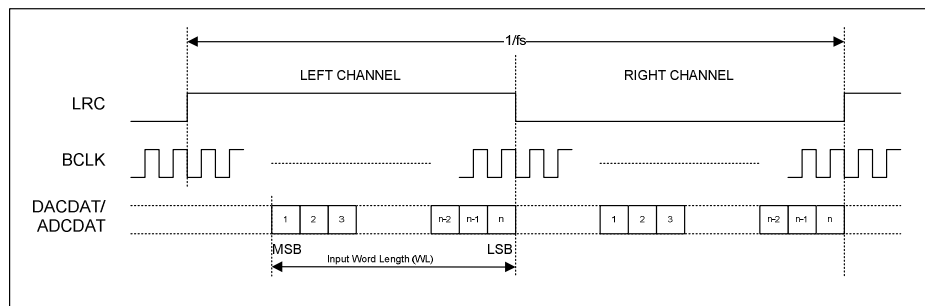
**BCLK FREQUENCY**

The BCLK frequency is controlled relative to CLK\_SYS by the BCLK\_DIV divider. Internal clock divide and phase control mechanisms ensure that the BCLK and LRC edges will occur in a predictable and repeatable position relative to each other and relative to the data for a given combination of DAC/ADC sample rate and BCLK\_DIV settings.

BCLK\_DIV is defined in the "Digital Audio Interface Control" section. See also the "Clocking and Sample Rates" section for more information.

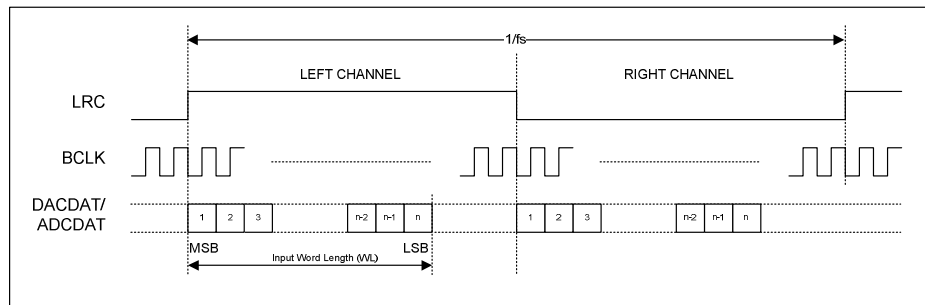
**AUDIO DATA FORMATS (NORMAL MODE)**

In Right Justified mode, the LSB is available on the last rising edge of BCLK before a LRC transition. All other bits are transmitted before (MSB first). Depending on word length, BCLK frequency and sample rate, there may be unused BCLK cycles after each LRC transition.



**Figure 41 Right Justified Audio Interface (assuming n-bit word length)**

In Left Justified mode, the MSB is available on the first rising edge of BCLK following a LRC transition. The other bits up to the LSB are then transmitted in order. Depending on word length, BCLK frequency and sample rate, there may be unused BCLK cycles before each LRC transition.



**Figure 42 Left Justified Audio Interface (assuming n-bit word length)**

In I<sup>2</sup>S mode, the MSB is available on the second rising edge of BCLK following a LRC transition. The other bits up to the LSB are then transmitted in order. Depending on word length, BCLK frequency and sample rate, there may be unused BCLK cycles between the LSB of one sample and the MSB of the next.

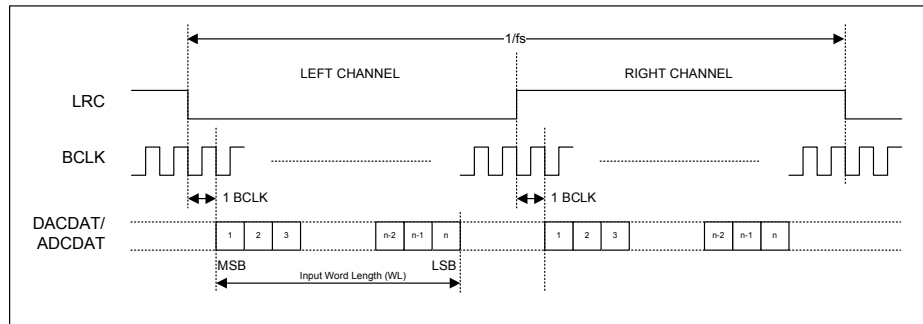


Figure 43 I2S Justified Audio Interface (assuming n-bit word length)

In DSP mode, the left channel MSB is available on either the 1<sup>st</sup> (mode B) or 2<sup>nd</sup> (mode A) rising edge of BCLK (selectable by AIF\_LRCLK\_INV) following a rising edge of LRC. Right channel data immediately follows left channel data. Depending on word length, BCLK frequency and sample rate, there may be unused BCLK cycles between the LSB of the right channel data and the next sample.

In device master mode, the LRC output will resemble the frame pulse shown in Figure 44 and Figure 45. In device slave mode, Figure 46 and Figure 47, it is possible to use any length of frame pulse less than 1/fs, providing the falling edge of the frame pulse occurs greater than one BCLK period before the rising edge of the next frame pulse.

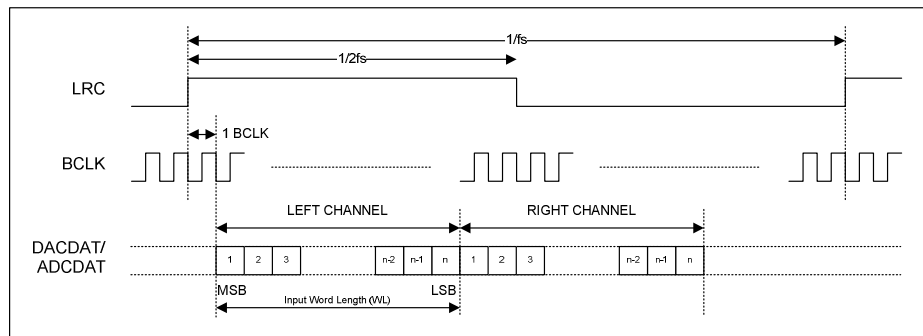


Figure 44 DSP Mode Audio Interface (mode A, AIF\_LRCLK\_INV=0, Master)

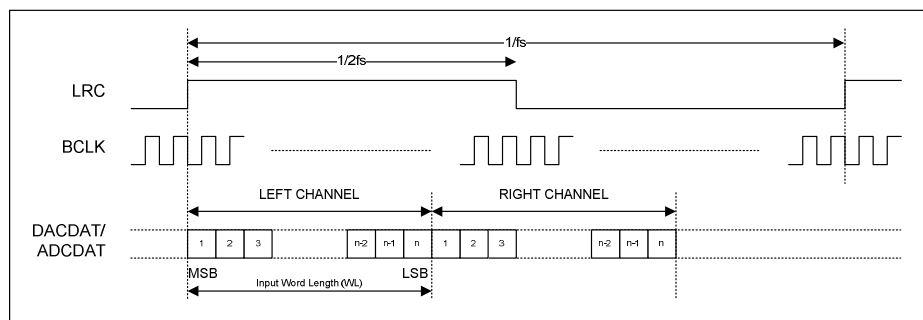


Figure 45 DSP Mode Audio Interface (mode B, AIF\_LRCLK\_INV=1, Master)

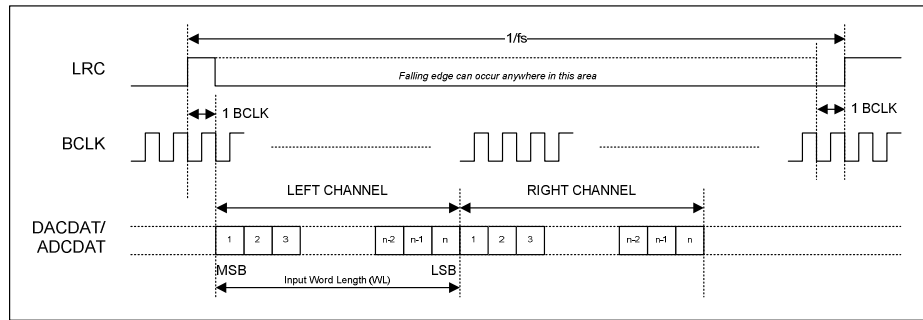


Figure 46 DSP Mode Audio Interface (mode A, AIF\_LRCLK\_INV=0, Slave)

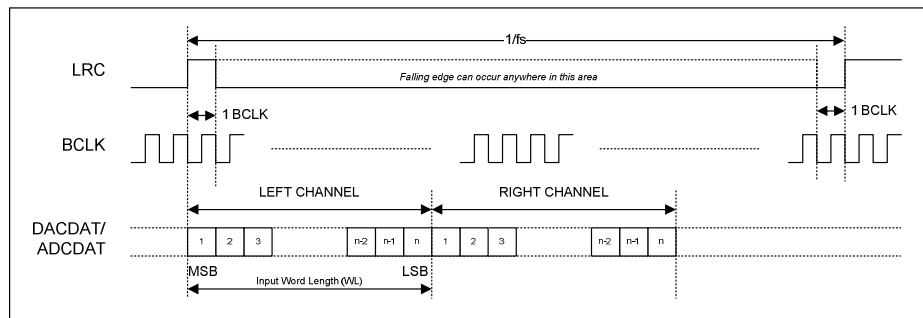


Figure 47 DSP Mode Audio Interface (mode B, AIF\_LRCLK\_INV=1, Slave)

PCM operation is supported in DSP interface mode. WM8903 ADC data that is output on the Left Channel will be read as mono PCM data by the receiving equipment. Mono PCM data received by the WM8903 will be treated as Left Channel data. This data may be routed to the Left/Right DACs as described in the "Digital Mixing" section.

### AUDIO DATA FORMATS (TDM MODE)

TDM is supported in master and slave mode and is enabled by register bits AIFADC\_TDM and AIFDAC\_TDM. All audio interface data formats support time division multiplexing (TDM) for ADC and DAC data.

Two time slots are available (Slot 0 and Slot 1), selected by register bits AIFADC\_TDM\_CHAN and AIFDAC\_TDM\_CHAN which control time slots for the ADC data and the DAC data.

When TDM is enabled, the ADCDAT pin will be tri-stated immediately before and immediately after data transmission, to allow another audio device to drive this signal line for the remainder of the sample period. It is important that two audio devices do not attempt to drive the data pin simultaneously, as this could result in a short circuit. See "Audio Interface Timing" for details of the ADCDAT output relative to BCLK signal. Note that it is possible to ensure a gap exists between transmissions by setting the transmitted word length to a value higher than the actual length of the data. For example, if 32-bit word length is selected where only 24-bit data is available, then the WM8903 interface will tri-state after transmission of the 24-bit data; this creates an 8-bit gap after the WM8903's TDM transmission slot.

When TDM is enabled, BCLK frequency must be high enough to allow data from both time slots to be transferred. The relative timing of Slot 0 and Slot 1 depends upon the selected data format as shown in Figure 48 to Figure 52.



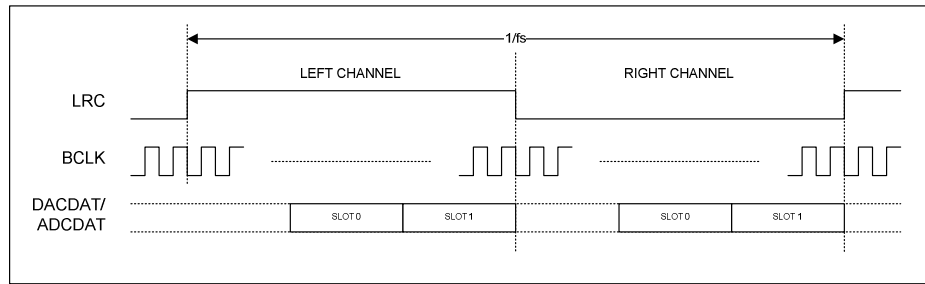


Figure 48 TDM in Right-Justified Mode

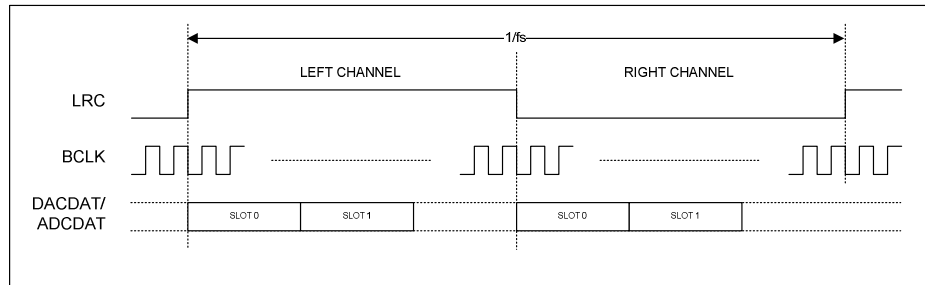


Figure 49 TDM in Left-Justified Mode

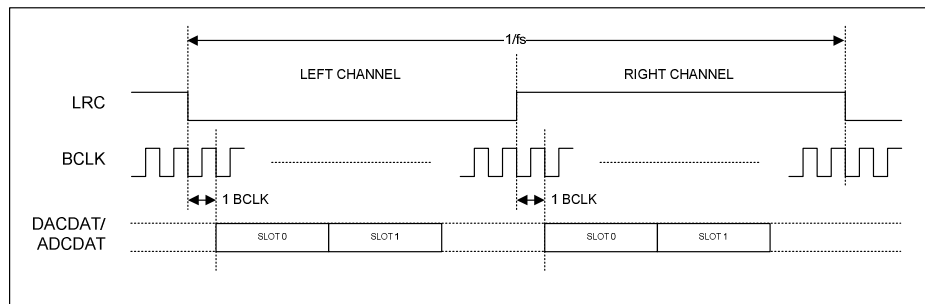


Figure 50 TDM in I<sup>2</sup>S Mode

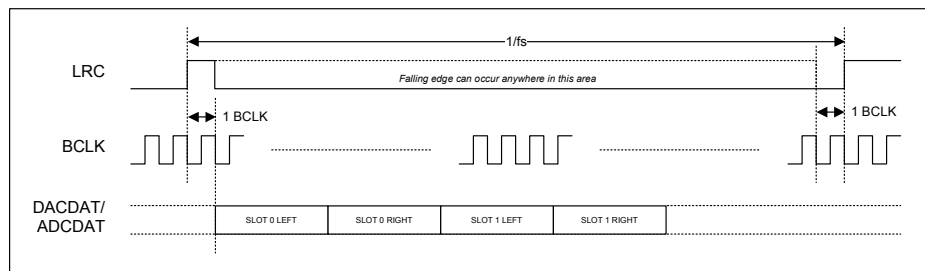


Figure 51 TDM in DSP Mode A

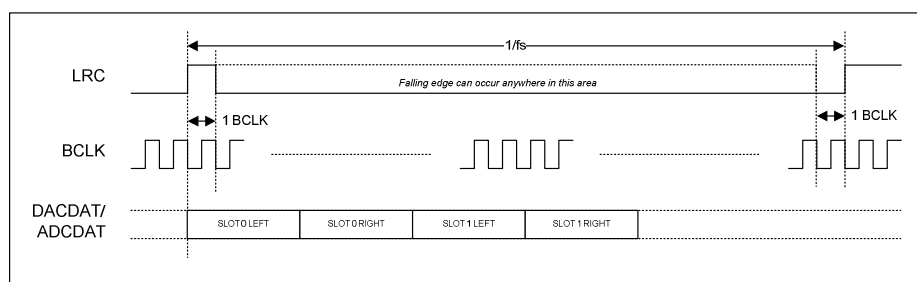


Figure 52 TDM in DSP Mode B

## DIGITAL AUDIO INTERFACE CONTROL

The register bits controlling audio data format, word length left/right channel data source and TDM are summarised in Table 56.

REGISTER ADDRESS	BIT	LABEL	DEFAULT	DESCRIPTION
R24 (18h) Audio Interface 0	12	DACL_DATINV	0	Left DAC Invert 0 = Left DAC output not inverted 1 = Left DAC output inverted
	11	DACR_DATINV	0	Right DAC Invert 0 = Right DAC output not inverted 1 = Right DAC output inverted
	7	AIFADCL_SRC	0	Left Digital Audio channel source 0 = Left ADC data is output on left channel 1 = Right ADC data is output on left channel
	6	AIFADCR_SRC	1	Right Digital Audio channel source 0 = Left ADC data is output on right channel 1 = Right ADC data is output on right channel
	5	AIFDACL_SRC	0	Left DAC Data Source Select 0 = Left DAC outputs left channel data 1 = Left DAC outputs right channel data
	4	AIFDACR_SRC	1	Right DAC Data Source Select 0 = Right DAC outputs left channel data 1 = Right DAC outputs right channel data
R25 (19h) Audio Interface 1	13	AIFDAC_TDM	0	DAC TDM Enable 0 = Normal DACDAT operation 1 = TDM enabled on DACDAT
	12	AIFDAC_TDM_CHAN	0	DACDAT TDM Channel Select 0 = DACDAT data input on slot 0 1 = DACDAT data input on slot 1
	11	AIFADC_TDM	0	ADC TDM Enable 0 = Normal ADCDAT operation 1 = TDM enabled on ADCDAT
	10	AIFADC_TDM_CHAN	0	ADCDAT TDM Channel Select 0 = ADCDAT outputs data on slot 0 1 = ADCDAT output data on slot 1

REGISTER ADDRESS	BIT	LABEL	DEFAULT	DESCRIPTION
	7	AIF_BCLK_INV	0	BCLK Invert 0 = BCLK not inverted 1 = BCLK inverted
	4	AIF_LRCLK_INV	0	LRC Polarity / DSP Mode A-B select.  Right, left and I <sup>2</sup> S modes – LRC polarity 0 = Not Inverted 1 = Inverted  DSP Mode – Mode A-B select 0 = MSB is available on 2nd BCLK rising edge after LRC rising edge (mode A) 1 = MSB is available on 1st BCLK rising edge after LRC rising edge (mode B)
	3:2	AIF_WL [1:0]	00	Digital Audio Interface Word Length 00 = 16 bits 01 = 20 bits 10 = 24 bits 11 = 32 bits
	1:0	AIF_FMT [1:0]	10	Digital Audio Interface Format 00 = Right Justified 01 = Left Justified 10 = I2S 11 = DSP
R38 (26h) ADC Digital 0	1	ADCL_DATINV	0	Left ADC Invert 0 = Left ADC output not inverted 1 = Left ADC output inverted
	0	ADCR_DATINV	0	Right ADC Invert 0 = Right ADC output not inverted 1 = Right ADC output inverted

Table 56 Digital Audio Interface Data Control

Note that the WM8903 is a 24-bit device. In 32-bit mode (AIF\_WL=11), the 8 LSBs are ignored on the receiving side and not driven on the transmitting side.

### BCLK AND LRCLK CONTROL

The audio interface can be programmed to operate in master mode or slave mode using the BCLK\_DIR and LRCLK\_DIR register bits. In master mode, the BCLK and LRCLK signals are generated by the WM8903 when any of the ADCs or DACs is enabled. In slave mode, the BCLK and LRCLK clock outputs are disabled by default to allow another digital audio interface to drive these pins.

It is also possible to force the BCLK or LRCLK signals to be output using BCLK\_DIR and LRCLK\_DIR, allowing mixed master and slave modes. The BCLK\_DIR and LRCLK\_DIR fields are defined in Table 57.

When BCLK is not selected (GP5\_FN ≠ 1), the WM8903 uses the MCLK input as the Bit Clock, provided that BCLK\_DIR is set to 0 to configure BCLK as an input, ie. BCLK slave mode. This configuration can offer power consumption benefits in addition to flexibility of GPIO functionality,

When the BCLK pin is an output (BCLK\_DIR=1), BCLK is derived from the internal CLK\_SYS signal (see "Clocking and Sample Rates"). In this case, the BCLK frequency is controlled in relation to CLK\_SYS by the BCLK\_DIV register field. When BCLK is an input, BCLK\_DIV has no effect.

When the LRC pin is an output (LRCLK\_DIR=1), LRC is derived from BCLK (irrespective of whether BCLK is an input or output). In this case, the LRC frequency is controlled in relation to BCLK by the LRCLK\_RATE register field. When LRC is an input, LRCLK\_RATE has no effect.

BCLK\_DIV and LRCLK\_RATE are defined in Table 57. The clocking scheme is illustrated in the "Clocking and Sample Rates" section - see Figure 55.

REGISTER ADDRESS	BIT	LABEL	DEFAULT	DESCRIPTION
R25 (19h) Audio Interface 1	9	LRCLK_DIR	0	Audio Interface LRC Direction 0 = LRC is input 1 = LRC is output
	6	BCLK_DIR	0	Audio Interface BCLK Direction 0 = BCLK is input 1 = BCLK is output
R26 (1Ah) Audio Interface 2	4:0	BCLK_DIV [4:0]	0_1000	BCLK Frequency (Master Mode) 00000 = CLK_SYS 00001 = Reserved 00010 = CLK_SYS / 2 00011 = CLK_SYS / 3 00100 = CLK_SYS / 4 00101 = CLK_SYS / 5 00110 = Reserved 00111 = CLK_SYS / 6 01000 = CLK_SYS / 8 (default) 01001 = CLK_SYS / 10 01010 = Reserved 01011 = CLK_SYS / 12 01100 = CLK_SYS / 16 01101 = CLK_SYS / 20 01110 = CLK_SYS / 22 01111 = CLK_SYS / 24 10000 = Reserved 10001 = CLK_SYS / 30 10010 = CLK_SYS / 32 10011 = CLK_SYS / 44 10100 = CLK_SYS / 48
R27 (1Bh) Audio Interface 3	10:0	LRCLK_RATE [10:0]	000_0010_0010	LRC Rate (Master Mode) LRC clock output = BCLK / LRCLK_RATE Integer (LSB = 1) Valid range: 8 to 2047 50:50 LRCLK duty cycle is only guaranteed with even values (8, 10, ... 2046).

**Table 57 Digital Audio Interface Clock Control**

**COMPANDING**

The WM8903 supports A-law and  $\mu$ -law companding on both transmit (ADC) and receive (DAC) sides as shown in Table 58.

REGISTER ADDRESS	BIT	LABEL	DEFAULT	DESCRIPTION
R24 (18h) Audio Interface 0	3	ADC_COMP	0	ADC Companding Enable 0 = disabled 1 = enabled
	2	ADC_COMPMODE	0	ADC Companding Type 0 = $\mu$ -law 1 = A-law
	1	DAC_COMP	0	DAC Companding Enable 0 = disabled 1 = enabled
	0	DAC_COMPMODE	0	DAC Companding Type 0 = $\mu$ -law 1 = A-law

**Table 58 Companding Control**

Companding uses a piecewise linear approximation of the following equations (as set out by ITU-T G.711 standard) for data compression:

$\mu$ -law (where  $\mu=255$  for the U.S. and Japan):

$$F(x) = \ln(1 + \mu|x|) / \ln(1 + \mu) \quad -1 \leq x \leq 1$$

A-law (where  $A=87.6$  for Europe):

$$F(x) = A|x| / (1 + \ln A) \quad x \leq 1/A$$

$$F(x) = (1 + \ln A|x|) / (1 + \ln A) \quad 1/A \leq x \leq 1$$

The companded data is also inverted as recommended by the G.711 standard (all 8 bits are inverted for  $\mu$ -law, all even data bits are inverted for A-law). The data will be transmitted as the first 8 MSBs of data.

Companding converts 13 bits ( $\mu$ -law) or 12 bits (A-law) to 8 bits using non-linear quantization. This provides greater precision for low amplitude signals than for high amplitude signals, resulting in a greater usable dynamic range than 8 bit linear quantization. The companded signal is an 8-bit word comprising sign (1 bit), exponent (3 bits) and mantissa (4 bits).

8-bit mode is selected whenever DAC\_COMP=1 or ADC\_COMP=1. The use of 8-bit data allows samples to be passed using as few as 8 BCLK cycles per LRC frame. When using DSP mode B, 8-bit data words may be transferred consecutively every 8 BCLK cycles.

8-bit mode (without Companding) may be enabled by setting DAC\_COMPMODE=1 or ADC\_COMPMODE=1, when DAC\_COMP=0 and ADC\_COMP=0.

BIT7	BIT [6:4]	BIT [3:0]
SIGN	EXPONENT	MANTISSA

**Table 59 8-bit Companded Word Composition**

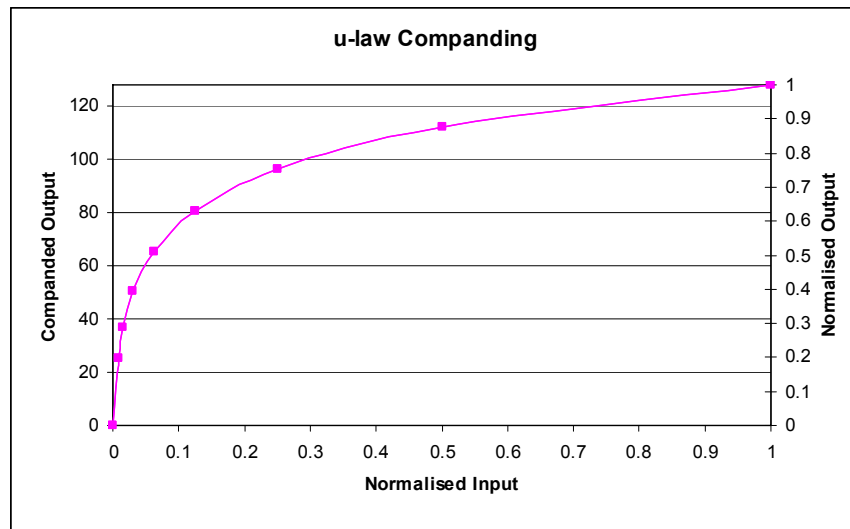


Figure 53  $\mu$ -Law Companding

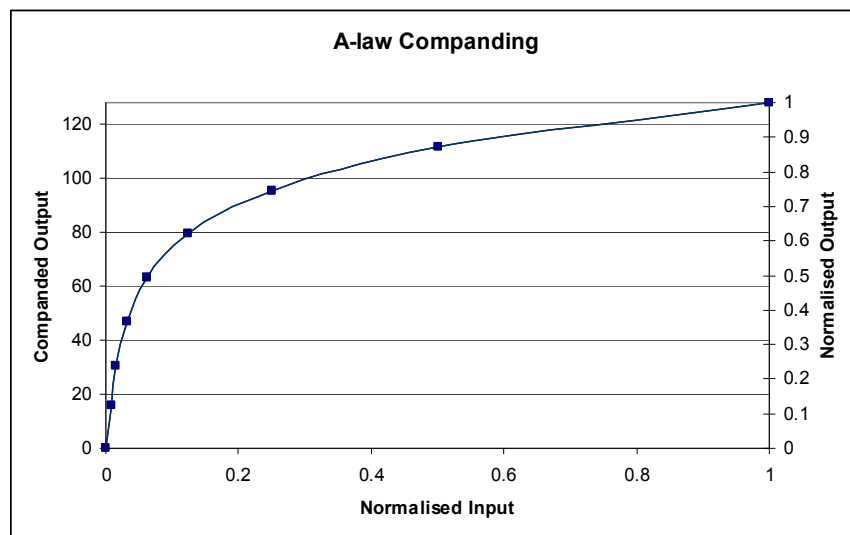


Figure 54 A-Law Companding

**LOOPBACK**

Setting the LOOPBACK register bit enables digital loopback. When this bit is set, the ADC digital data output is routed to the DAC digital data input path. The digital audio interface input (DACDAT) is not used when LOOPBACK is enabled.

REGISTER ADDRESS	BIT	LABEL	DEFAULT	DESCRIPTION
R24 (18h) Audio Interface 0	8	LOOPBACK	0	Digital Loopback Function 0 = No loopback 1 = Loopback enabled (ADC data output is directly input to DAC data input)

Table 60 Loopback Control

**Note:** When the digital sidetone is enabled, ADC data will continue to be added to DAC data when loopback is enabled.

## CLOCKING AND SAMPLE RATES

The WM8903 supports a wide range of standard audio sample rates from 8kHz to 96kHz. When the DAC and ADC are both enabled, they operate at the same sample rate,  $f_s$ . Oversample rates of 64fs or 128fs are supported (based on a 48kHz sample rate).

Note that simultaneous ADC and DAC operation at 88.2kHz or 96kHz is not possible. Digital microphone operation is not supported at 88.2kHz or 96kHz sample rates. The clocking options for 88.2kHz or 96kHz ADC operation are restricted to specific configurations only, as detailed in this section.

The internal clocks for the WM8903 are all derived from a common internal clock source, CLK\_SYS. This clock is the reference for the ADCs, DACs, DSP core functions, digital audio interface, DC servo control and other internal functions.

CLK\_SYS can either be derived directly from MCLK, or may be generated from a Frequency Locked Loop (FLL) using MCLK, BCLK or LRC as a reference. Many commonly-used audio sample rates can be derived directly from typical MCLK frequencies; the FLL provides additional flexibility for a wide range of MCLK frequencies. To avoid audible glitches, all clock configurations must be set up before enabling playback. The FLL can be used to generate a free-running clock in the absence of an external reference source; see "Frequency Locked Loop (FLL)" for further details.

The WM8903 supports automatic clocking configuration. The programmable dividers associated with the ADCs, DACs, DSP core functions and DC servo are configured automatically, with values determined from the SAMPLE\_RATE, CLK\_SYS\_RATE and CLK\_SYS\_MODE fields. Note that the user must also configure the Digital Audio Interface.

A 256kHz clock, supporting the Control Write Sequencer, MICBIAS Current Detect filtering and a number of internal functions, is derived from CLK\_SYS. This clock is enabled by WSMD\_CLK\_ENA.

A slow clock, TOCLK, is used to de-bounce the button/accessory detect inputs, and to set the timeout period for volume updates when zero-cross detect is used. This clock is enabled by TO\_ENA.

The Charge Pump and DC servo control functions are clocked from CLK\_SYS.

In master mode, BCLK is derived from CLK\_SYS via a programmable divider set by BCLK\_DIV. In master mode, the LRC is derived from BCLK via a programmable divider LRCLK\_RATE. The LRC can be derived from an internal or external BCLK source, allowing mixed master/slave operation.

The overall clocking scheme for the WM8903 is illustrated in Figure 55. Note that BCLK and LRC are described in the "Digital Audio Interface" section.





### CLK\_SYS CONTROL

The CLK\_SRC\_SEL bit is used to select the source for CLK\_SYS. The source may be either the MCLK input or the FLL output. The selected source may be adjusted by the MCLKDIV2 divider to generate CLK\_SYS. These register fields are described in Table 61. See “Frequency Locked Loop (FLL)” for more details of the Frequency Locked Loop clock generator.

The CLK\_SYS signal is enabled by register bit CLK\_SYS\_ENA. This bit should be set to 1 for normal operation with MCLK applied. This bit should be set to 0 when reconfiguring clock sources. It is not recommended to change CLK\_SRC\_SEL while the CLK\_SYS\_ENA bit is set.

The following operating frequency limits must be observed when configuring CLK\_SYS. Failure to observe these limits will result in degraded noise performance and/or incorrect ADC/DAC functionality.

- If DAC\_OSR = 0 then CLK\_SYS  $\geq$  3MHz
- If DAC\_OSR = 1 then CLK\_SYS  $\geq$  6MHz

For DAC operation up to 48kHz sample rate, the following CLK\_SYS limits are applicable. These conditions are applicable whenever DACL\_ENA = 1 or DACR\_ENA = 1.

Note that the ADC operation limits must also be observed if either ADC is enabled. See “Digital-to-Analogue Converter (DAC)” for definitions of DAC\_MONO and DAC\_OSR.

- If DAC\_MONO = 0 and DAC\_OSR = 0, then CLK\_SYS  $\geq$  128 x fs
- If DAC\_MONO = 0 and DAC\_OSR = 1, then CLK\_SYS  $\geq$  256 x fs
- If DAC\_MONO = 1 and DAC\_OSR = 0, then CLK\_SYS  $\geq$  64 x fs
- If DAC\_MONO = 1 and DAC\_OSR = 1, then CLK\_SYS  $\geq$  128 x fs

For ADC operation up to 48kHz sample rate, the following CLK\_SYS limits are applicable. These conditions are applicable whenever ADCL\_ENA = 1 or ADCR\_ENA = 1.

Note that the DAC operation limits must also be observed if either DAC is enabled. See “Analogue-to-Digital Converter (ADC)” for the definition of ADC\_OSR.

- If ADC\_OSR = 0, then CLK\_SYS  $\geq$  128 x fs
- If ADC\_OSR = 1, then CLK\_SYS  $\geq$  256 x fs

Further requirements for 88.2kHz and 96kHz operation are provided later in this section. Note that simultaneous ADC and DAC operation at 88.2kHz or 96kHz is not possible.

The clocking of the ADC and DAC circuits is derived from CLK\_DSP, which is enabled by CLK\_DSP\_ENA. (Note that CLK\_SYS must also be enabled.)

A 256kHz clock required for the Control Write Sequencer and MICBIAS Current Detect filtering is derived from CLK\_SYS. The 256kHz clock is enabled by WSMD\_CLK\_ENA.

The slow clock (TOCLK) required for input signal de-bouncing and volume update timeout functions is derived from the 256kHz clock. The TOCLK clock is enabled by TO\_ENA.

The CLK\_SYS control register fields are defined in Table 61.

REGISTER ADDRESS	BIT	LABEL	DEFAULT	DESCRIPTION
R20 (14h) Clock Rates 0	0	MCLKDIV2	0	Enables divide by 2 on MCLK 0 = CLK_SYS = MCLK 1 = CLK_SYS = MCLK / 2
R21 (15h) Clock Rates 1	15	CLK_SRC_SEL	0	SYSCLK Source Select 0 = MCLK 1 = FLL output
R22 (16h) Clock Rates 2	2	CLK_SYS_ENA	0	System Clock enable 0 = Disabled 1 = Enabled
	1	CLK_DSP_ENA	0	DSP Clock enable 0 = Disabled 1 = Enabled
	0	TO_ENA	0	Zero Cross timeout enable 0 = Disabled 1 = Enabled
R108 (6Ch) Write Sequencer 0	8	WSMD_CLK_ENA	0	Write Sequencer / Mic Detect Clock Enable. 0 = Disabled 1 = Enabled

**Table 61 MCLK and CLK\_SYS Control**

### CONTROL INTERFACE CLOCKING

Register map access is possible with or without a Master Clock (MCLK). However, if CLK\_SYS\_ENA has been set to 1, then a Master Clock must be present for control register Read/Write operations. If CLK\_SYS\_ENA = 1 and MCLK is not present, then register access will be unsuccessful. (Note that read/write access to register R22, containing CLK\_SYS\_ENA, is always possible.)

If it cannot be assured that MCLK is present when accessing the register map, then it is required to set CLK\_SYS\_ENA = 0 to ensure correct operation.

It is possible to use the WM8903 analogue bypass paths to the differential line outputs (LON/LOP and RON/ROP) without MCLK. Note that MCLK is always required when using HPOUTL, HPOUTR, LINEOUTL or LINEOUTR.

### AUTOMATIC CLOCKING CONFIGURATION

The WM8903 supports a wide range of standard audio sample rates from 8kHz to 96kHz. The Automatic Clocking Configuration mode simplifies the configuration of the clock dividers in the WM8903 by deriving most of the necessary parameters from a minimum number of user registers.

The SAMPLE\_RATE field selects the sample rate, fs, of the ADC and DAC. Note that the same sample rate always applies to the ADC and DAC.

The CLK\_SYS\_RATE and CLK\_SYS\_MODE fields must be set according to the ratio of CLK\_SYS to fs. (Note that the internal clock CLK\_SYS is derived from MCLK as controlled by MCLKDIV2). When these fields are set correctly, the Sample Rate Decoder circuit automatically determines the clocking configuration for all other circuits within the WM8903.

The DSP clocking is enabled by CLK\_DSP\_ENA; see Table 61 for details of this register.

REGISTER ADDRESS	BIT	LABEL	DEFAULT	DESCRIPTION
R21 (15h) Clock Rates 1	13:10	CLK_SYS_RATE [3:0]	0011	CLK_SYS_RATE and CLK_SYS_MODE together determine the clock division ratio (CLK_SYS / fs); see Table 63
	9:8	CLK_SYS_MODE [1:0]	00	
	3:0	SAMPLE_RATE [3:0]	1000	Selects the Sample Rate (fs) 0000 = 8kHz 0001 = 11.025kHz 0010 = 12kHz 0011 = 16kHz 0100 = 22.05kHz 0101 = 24kHz 0110 = 32kHz 0111 = 44.1kHz 1000 = 48kHz 1001 = 88.2kHz (Not available for Digital Microphone. Not used for 88.2kHz ADC.) 1010 = 96kHz (Not available for Digital Microphone. Not used for 96kHz ADC) 1011 to 1111 = Reserved  If the desired sample rate is not listed in this table, then the closest alternative should be chosen.

Table 62 Automatic Clocking Configuration Control

Available CLK_SYS / f <sub>s</sub> ratios				
		CLK_SYS_MODE		
		00 <i>(default)</i>	01 <i>(USB modes)</i>	10
CLK_SYS_RATE	0000	64	68	125
	0001	128	136	125
	0010	192	204	250
	0011	256	272	250
	0100	384	408	375
	0101	512	544	500
	0110	768	816	750
	0111	1024	1088	1000
	1000	1408	1496	1000
	1001	1536	1632	1500
1010 to 1111		Reserved		

Table 63 Sample Rate Decoder Control

The clock division ratios available with CLK\_SYS\_MODE = 00 are suitable for use with standard audio master clocks. For example, with a 12.288MHz CLK\_SYS and 48kHz sample rate, the CLK\_SYS to fs ratio is 256. In this case, the required setting for CLK\_SYS\_RATE is 0011, as shown above.

### USB CLOCKING MODE

The clock division ratios with CLK\_SYS\_MODE = 01 or CLK\_SYS\_MODE = 10 allow compatibility with a 12MHz USB clock, at sample rates up to 48kHz. For example, with a 12MHz (USB) clock and 8kHz sample rate, the CLK\_SYS to fs ratio is 1500. In this case, the required setting for CLK\_SYS\_RATE is 1001.

Note that 44.1kHz and related sample rates are approximate when derived from a USB clock. For example, with a 12MHz MCLK and a division ratio of 272, the exact sample rate obtained is 44.118kHz rather than 44.1kHz. This 0.04% offset is inaudible and can be ignored. 48kHz and related sample rates are exact in all modes of operation, provided that MCLK itself is exact.

### ADC / DAC OPERATION AT 88.2K / 96K

The WM8903 supports ADC or DAC operation at 88.2kHz and 96kHz sample rates. This section details specific conditions applicable to these operating modes. Note that simultaneous ADC and DAC operation at 88.2kHz or 96kHz is not possible.

For DAC operation at 88.2kHz or 96kHz sample rates, the available clocking configurations are detailed in Table 64.

Note that, for DAC operation at 88.2kHz or 96kHz sample rates, the ADCs must both be disabled (ADCL\_ENA = 0 and ADCR\_ENA = 0). Also, the DAC\_OSR register should be set to 0.

The CLK\_SYS frequency is derived from MCLK. Note that the maximum MCLK frequency is defined in the "Signal Timing Requirements" section.

SAMPLE RATE	REGISTER CONFIGURATION		CLK_SYS / fs RATIO
88.2kHz	SAMPLE_RATE = 1001 CLK_SYS_RATE = 0001	CLK_SYS_MODE = 00	128 x fs
		CLK_SYS_MODE = 01	136 x fs
		CLK_SYS_MODE = 10	125 x fs
96kHz	SAMPLE_RATE = 1010 CLK_SYS_RATE = 0001	CLK_SYS_MODE = 00	128 x fs
		CLK_SYS_MODE = 10	125 x fs

**Table 64 DAC Operation at 88.2kHz and 96kHz Sample Rates**

For ADC operation at 88.2kHz or 96kHz sample rates, the available clocking configurations are detailed in Table 65.

Note that ADC operation at these sample rates is achieved by setting the SAMPLE\_RATE field to half the required sample rate (eg. select 48kHz for 96kHz mode). In these modes, the BCLK\_DIV field is set to select BCLK at double the normal rate.

Note that, for ADC operation at 88.2kHz or 96kHz sample rates, the DACs must both be disabled (DACL\_ENA = 0 and DACR\_ENA = 0).

The CLK\_SYS frequency is derived from MCLK. Note that the maximum MCLK frequency is defined in the "Signal Timing Requirements" section.

SAMPLE RATE	REGISTER CONFIGURATION		CLK_SYS / fs RATIO
88.2kHz	SAMPLE_RATE = 0111 CLK_SYS_RATE = 0001 CLK_SYS_MODE = 00	BCLK_DIV = 00010 LRCLK_RATE = 040h	128 x fs
96kHz	SAMPLE_RATE = 1000 CLK_SYS_RATE = 0001 CLK_SYS_MODE = 00	BCLK_DIV = 00010 LRCLK_RATE = 040h	128 x fs

**Table 65 ADC Operation at 88.2kHz and 96kHz Sample Rates**

### DIGITAL MICROPHONE (DMIC) OPERATION

When GPIO1/DMIC\_LR is configured as DMIC\_LR Clock output, the WM8903 outputs a clock which supports Digital Microphone operation at a multiple of the ADC sampling rate. The precise clock frequency varies according to the MCLK frequency, the SAMPLE\_RATE field and other settings. The clock frequency is always within the range 1MHz - 3MHz, and some examples are shown in Table 66.

SAMPLE RATE	CLK_SYS	CLK_SYS RATIO	DMIC_LR FREQUENCY	DMIC_LR RATIO
8kHz	12.288MHz	1536fs	1.024MHz	128fs
8kHz	12MHz	1500fs	1.200MHz	150fs
16kHz	12.288MHz	768fs	2.048MHz	128fs
16kHz	12MHz	750fs	2.400MHz	150fs
48kHz	12.288MHz	256fs	1.536MHz	32fs
48kHz	12MHz	250fs	2.400MHz	50fs
44.1kHz	11.2896MHz	256fs	2.822MHz	64fs
44.1kHz	12MHz	272fs	3.000MHz	68fs
32kHz	12MHz	375fs	2.400MHz	75fs
24kHz	12MHz	500fs	2.400MHz	100fs
12kHz	12MHz	1000fs	1.500MHz	125fs

**Table 66 Digital Microphone Clock**

Note that the 88.2kHz and 96kHz sample rate settings are not valid for Digital Microphone operation.

### FREQUENCY LOCKED LOOP (FLL)

The integrated FLL can be used to generate CLK\_SYS from a wide variety of different reference sources and frequencies. The FLL can use either MCLK, BCLK or LRC as its reference, which may be a high frequency (eg. 12.288MHz) or low frequency (eg. 32.768kHz) reference. The FLL is tolerant of jitter and may be used to generate a stable CLK\_SYS from a less stable input signal. The FLL characteristics are summarised in "Electrical Characteristics".

Note that the FLL can be used to generate a free-running clock in the absence of an external reference source. This is described in the "Free-Running FLL Clock" section below.

The FLL is enabled using the FLL\_ENA register bit. Note that, when changing FLL settings, it is recommended that the digital circuit be disabled via FLL\_ENA and then re-enabled after the other register settings have been updated. When changing the input reference frequency  $F_{REF}$ , it is recommended the FLL be reset by setting FLL\_ENA to 0.

The FLL\_CLK\_SRC field allows MCLK, BCLK or LRC to be selected as the input reference clock.

The field FLL\_CLK\_REF\_DIV provides the option to divide the input reference (MCLK, BCLK or LRC) by 1, 2, 4 or 8. This field should be set to bring the reference down to 13.5MHz or below. For best performance, it is recommended that the highest possible frequency - within the 13.5MHz limit - should be selected.

The field FLL\_CTRL\_RATE controls internal functions within the FLL; it is recommended that only the default setting be used for this parameter. FLL\_GAIN controls the internal loop gain and should be set to the recommended value quoted in Table 69.

The FLL output frequency is directly determined from FLL\_FRATIO, FLL\_OUTDIV and the real number represented by FLL\_N and FLL\_K. The field FLL\_N is an integer (LSB = 1); FLL\_K is the fractional portion of the number (MSB = 0.5). The fractional portion is only valid in Fractional Mode when enabled by the field FLL\_FRAC.

It is recommended that fractional Mode (FLL\_FRAC = 1) is selected at all times. Power consumption in the FLL is reduced in integer mode; however, the performance may also be reduced, with increased noise or jitter on the output.

If low power consumption is required, then FLL settings must be chosen when N.K is an integer (ie. FLL\_K = 0). In this case, the fractional mode can be disabled by setting FLL\_FRAC = 0.

For best FLL performance, a non-integer value of N.K is required. In this case, the fractional mode must be enabled by setting FLL\_FRAC = 1. The FLL settings must be adjusted, if necessary, to produce a non-integer value of N.K.

The FLL output frequency is generated according to the following equation:

$$F_{OUT} = (F_{VCO} / FLL\_OUTDIV)$$

The FLL operating frequency,  $F_{VCO}$  is set according to the following equation:

$$F_{VCO} = (F_{REF} \times N.K \times FLL\_FRATIO)$$

See Table 69 for the coding of the FLL\_OUTDIV and FLL\_FRATIO fields.

$F_{REF}$  is the input frequency, as determined by FLL\_CLK\_REF\_DIV.

$F_{VCO}$  must be in the range 90-100 MHz. Frequencies outside this range cannot be supported.

Note that the output frequencies that do not lie within the ranges quoted above cannot be guaranteed across the full range of device operating temperatures.

In order to follow the above requirements for  $F_{VCO}$ , the value of FLL\_OUTDIV should be selected according to the desired output  $F_{OUT}$ , as described in Table 67. The divider, FLL\_OUTDIV, must be set so that  $F_{VCO}$  is in the range 90-100MHz.

OUTPUT FREQUENCY $F_{OUT}$	FLL_OUTDIV
2.8125 MHz - 3.125 MHz	4h (divide by 32)
5.625 MHz - 6.25 MHz	3h (divide by 16)
11.25 MHz - 12.5 MHz	2h (divide by 8)
22.5 MHz - 25 MHz	1h (divide by 4)

**Table 67 Selection of FLL\_OUTDIV**

The value of FLL\_FRATIO should be selected as described in Table 68.

REFERENCE FREQUENCY $F_{REF}$	FLL_FRATIO
1MHz - 13.5MHz	0h (divide by 1)
256kHz - 1MHz	1h (divide by 2)
128kHz - 256kHz	2h (divide by 4)
64kHz - 128kHz	3h (divide by 8)
Less than 64kHz	4h (divide by 16)

**Table 68 Selection of FLL\_FRATIO**

In order to determine the remaining FLL parameters, the FLL operating frequency,  $F_{VCO}$ , must be calculated, as given by the following equation:

$$F_{VCO} = (F_{OUT} \times FLL\_OUTDIV)$$

The value of FLL\_N and FLL\_K can then be determined as follows:

$$N.K = F_{VCO} / (FLL\_FRATIO \times F_{REF})$$

See Table 69 for the coding of the FLL\_OUTDIV and FLL\_FRATIO fields.

Note that  $F_{REF}$  is the input frequency, after division by FLL\_CLK\_REF\_DIV, where applicable.

In FLL Fractional Mode, the fractional portion of the N.K multiplier is held in the FLL\_K register field. This field is coded as a fixed point quantity, where the MSB has a weighting of 0.5. Note that, if desired, the value of this field may be calculated by multiplying K by  $2^{16}$  and treating FLL\_K as an integer value, as illustrated in the following example:

If  $N.K = 8.192$ , then  $K = 0.192$

Multiplying K by  $2^{16}$  gives  $0.192 \times 65536 = 12582.912$  (decimal)

Apply rounding to the nearest integer = 12583 (decimal) = 3127 (hex)

For best performance, FLL Fractional Mode should always be used. Therefore, if the calculations yield an integer value of N.K, then it is recommended to adjust FLL\_FRATIO in order to obtain a non-integer value of N.K. Care must always be taken to ensure that the FLL operating frequency,  $F_{VCO}$ , is within its recommended limits of 90-100 MHz.

The register fields that control the FLL are described in Table 69. Example settings for a variety of reference frequencies and output frequencies are shown in Table 70.

REGISTER ADDRESS	BIT	LABEL	DEFAULT	DESCRIPTION
R128 (80h) FLL Control 1	7:4	FLL_GAIN [3:0]	0h	Gain applied to error 0000 = x 1 (Recommended value) 0001 = x 2 0010 = x 4 0011 = x 8 0100 = x 16 0101 = x 32 0110 = x 64 0111 = x 128 1000 = x 256  Recommended that this register is not changed from default.
	3	FLL_HOLD	0	FLL Hold Select 0 = Disabled 1 = Enabled  This feature enables free-running mode in FLL when reference clock is removed
	2	FLL_FRAC	0	Fractional enable 0 = Integer Mode 1 = Fractional Mode  Fractional Mode is recommended in all cases
	0	FLL_ENA	0	FLL Enable 0 = Disabled 1 = Enabled
R129 (81h) FLL Control 2	12:11	FLL_CLK_SRC [1:0]	00	FLL Clock source 00 = MCLK 01 = BCLK 10 = LRC 11 = Reserved

REGISTER ADDRESS	BIT	LABEL	DEFAULT	DESCRIPTION
	10:9	FLL_CLK_REF_DIV [1:0]	00	FLL Clock Reference Divider 00 = MCLK / 1 01 = MCLK / 2 10 = MCLK / 4 11 = MCLK / 8  MCLK (or other input reference) must be divided down to $\leq 13.5\text{MHz}$ . For lower power operation, the reference clock can be divided down further if desired.
	8:6	FLL_CTRL_RATE [2:0]	000	Frequency of the FLL control block 000 = $F_{VCO} / 1$ (Recommended value) 001 = $F_{VCO} / 2$ 010 = $F_{VCO} / 3$ 011 = $F_{VCO} / 4$ 100 = $F_{VCO} / 5$ 101 = $F_{VCO} / 6$ 110 = $F_{VCO} / 7$ 111 = $F_{VCO} / 8$  Recommended that this register is not changed from default.
	5:3	FLL_OUTDIV [2:0]	000	$F_{OUT}$ clock divider 000 = 2 001 = 4 010 = 8 011 = 16 100 = 32 101 = 64 110 = 128 111 = 256  ( $F_{OUT} = F_{VCO} / \text{FLL\_OUTDIV}$ )
	2:0	FLL_FRATIO [2:0]	000	$F_{VCO}$ clock divider 000 = divide by 1 001 = divide by 2 010 = divide by 4 011 = divide by 8 1XX = divide by 16  000 recommended for $F_{REF} > 1\text{MHz}$ 100 recommended for $F_{REF} < 64\text{kHz}$
R130 (82h) FLL Control 3	15:0	FLL_K [15:0]	0000h	Fractional multiply for $F_{REF}$ (MSB = 0.5)
R131 (83h) FLL Control 4	9:0	FLL_N [9:0]	000h	Integer multiply for $F_{REF}$ (LSB = 1)

Table 69 FLL Register Map



### FREE-RUNNING FLL CLOCK

The FLL can generate a clock signal even when the external reference is removed. It should be noted that the accuracy of this clock is reduced, and a reference source should always be used where possible. In free-running modes, the FLL is not sufficiently accurate for hi-fi audio applications. The free-running modes are suitable for clocking other functions, including the Write Sequencer and DC servo control. The free-running mode can be used to support the analogue input (bypass) audio paths.

A clock reference is required for initial configuration of the FLL as described above. For free-running operation, the FLL\_HOLD bit should be set, as described in Table 69. When FLL\_HOLD is set, the FLL will continue to generate a stable output clock after the reference input is stopped or disconnected.

Note that the FLL must be selected as the CLK\_SYS source by setting CLK\_SRC\_SEL (see Table 61). Note that, in the absence of any reference clock, the FLL output is subject to a very wide tolerance. See "Electrical Characteristics" for details of the FLL accuracy.

### GPIO OUTPUTS FROM FLL

The WM8903 has an internal signal which indicates whether the FLL Lock has been achieved. The FLL Lock status is an input to the Interrupt control circuit and can be used to trigger an Interrupt event - see "Interrupts".

The FLL Lock signal can be output directly on a GPIO pin as an external indication of FLL Lock. See "General Purpose Input/Output (GPIO)" for details of how to configure a GPIO pin to output the FLL Lock signal.

The FLL Clock can be output directly on a GPIO pin as a clock signal for other circuits. Note that the FLL Clock may be output even if the FLL is not selected as the WM8903 CLK\_SYS source. The clocking configuration is illustrated in Figure 55. See "General Purpose Input/Output (GPIO)" for details of how to configure a GPIO pin to output the FLL Clock.

### EXAMPLE FLL CALCULATION

To generate 12.288 MHz output ( $F_{OUT}$ ) from a 12.000 MHz reference clock ( $F_{REF}$ ):

- Set FLL\_CLK\_REF\_DIV in order to generate  $F_{REF} \leq 13.5\text{MHz}$ :  
FLL\_CLK\_REF\_DIV = 00 (divide by 1)
- Set FLL\_CTRL\_RATE to the recommended setting:  
FLL\_CTRL\_RATE = 000 (divide by 1)
- Set FLL\_GAIN to the recommended setting:  
FLL\_GAIN = 0000 (multiply by 1)
- Set FLL\_OUTDIV for the required output frequency as shown in Table 67:-  
 $F_{OUT} = 12.288\text{ MHz}$ , therefore FLL\_OUTDIV = 2h (divide by 8)
- Set FLL\_FRATIO for the given reference frequency as shown in Table 68:  
 $F_{REF} = 12\text{MHz}$ , therefore FLL\_FRATIO = 0h (divide by 1)
- Calculate  $F_{VCO}$  as given by  $F_{VCO} = F_{OUT} \times FLL\_OUTDIV$ :-  
 $F_{VCO} = 12.288 \times 8 = 98.304\text{MHz}$
- Calculate N.K as given by  $N.K = F_{VCO} / (FLL\_FRATIO \times F_{REF})$ :  
 $N.K = 98.304 / (1 \times 12) = 8.192$
- Determine FLL\_N and FLL\_K from the integer and fractional portions of N.K:-  
FLL\_N is 8. FLL\_K is 0.192
- Confirm that N.K is a fractional quantity and set FLL\_FRAC:  
N.K is fractional. Set FLL\_FRAC = 1.  
Note that, if N.K is an integer, then an alternative value of FLL\_FRATIO should be selected in order to produce a fractional value of N.K.

**EXAMPLE FLL SETTINGS**

Table 70 provides example FLL settings for generating common CLK\_SYS frequencies from a variety of low and high frequency reference inputs.

F <sub>REF</sub>	F <sub>OUT</sub>	FLL_CLK_REF_DIV	F <sub>vco</sub>	FLL_N	FLL_K	FLL_FRATIO	FLL_OUTDIV	FLL_FRAC
32.000 kHz	12.288 MHz	Divide by 1 (0h)	98.304 MHz	192 (0C0h)	0 (0000h)	16 (4h)	8 (2h)	0
32.000 kHz	11.2896 MHz	Divide by 1 (0h)	90.3168 MHz	176 (0B0h)	0.4 (6666h)	16 (4h)	8 (2h)	1
32.768 kHz	12.288 MHz	Divide by 1 (0h)	98.304 MHz	187 (0BBh)	0.5 (8000h)	16 (4h)	8 (2h)	1
32.768 kHz	11.288576 MHz	Divide by 1 (0h)	90.3086 MHz	172 (0ACh)	0.25 (4000h)	16 (4h)	8 (2h)	1
32.768 kHz	11.2896 MHz	Divide by 1 (0h)	90.3168 MHz	172 (0ACh)	0.2656 (4400h)	16 (4h)	8 (2h)	1
48 kHz	12.288 MHz	Divide by 1 (0h)	98.304 MHz	128 (080h)	0 (0000h)	16 (4h)	8 (2h)	0
11.3636 MHz	12.368544 MHz	Divide by 1 (0h)	98.9484 MHz	8 (008h)	0.707483 (B51Eh)	1 (0h)	8 (2h)	1
12.000 MHz	12.288 MHz	Divide by 1 (0h)	98.304 MHz	8 (008h)	0.192 (3127h)	1 (0h)	8 (2h)	1
12.000 MHz	11.289597 MHz	Divide by 1 (0h)	90.3168 MHz	7 (007h)	0.526398 (86C2h)	1 (0h)	8 (2h)	1
12.288 MHz	12.288 MHz	Divide by 1 (0h)	98.304 MHz	8 (008h)	0 (0000h)	1 (0h)	8 (2h)	0
12.288 MHz	11.2896 MHz	Divide by 1 (0h)	90.3168 MHz	7 (007h)	0.35 (599Ah)	1 (0h)	8 (2h)	1
13.000 MHz	12.287990 MHz	Divide by 1 (0h)	98.3039 MHz	7 (007h)	0.56184 (8FD5h)	1 (0h)	8 (2h)	1
13.000 MHz	11.289606 MHz	Divide by 1 (0h)	90.3168 MHz	6 (006h)	0.94745 (F28Ch)	1 (0h)	8 (2h)	1
19.200 MHz	12.287988 MHz	Divide by 2 (1h)	98.3039 MHz	10 (00Ah)	0.23999 (3D70h)	1 (0h)	8 (2h)	1
19.200 MHz	11.289588 MHz	Divide by 2 (1h)	90.3167 MHz	9 (009h)	0.40799 (6872h)	1 (0h)	8 (2h)	1

**Table 70 Example FLL Settings**

## GENERAL PURPOSE INPUT/OUTPUT (GPIO)

The WM8903 provides five multi-function pins which can be configured to provide a number of different functions. These are digital input/output pins on the DBVDD power domain. The GPIO pins are:

- GPIO1/DMIC\_LR
- GPIO2/DMIC\_DAT
- GPIO3/ADDR
- INTERRUPT (GPIO4)
- BCLK (GPIO5)

Each general purpose I/O pin can be configured to be a GPIO input or configured as one of a number of output functions. Signal de-bouncing can be selected on GPIO input pins for use with jack/button detect applications. Table 71 lists the functions that are available on each of these pins. The default function is highlighted for each pin.

GPIO Pin Function	GPIO PINS				
	GPIO1/D MIC_LR	GPIO2/D MIC_DAT	GPIO3/ ADDR	INTERRUPT (GPIO4)	BCLK (GPIO5)
GPIO output	<b>Yes</b>	<b>Yes</b>	<b>Yes</b>	Yes	Yes
BCLK input/output	No	No	No	No	<b>Yes</b>
Interrupt output (IRQ)	Yes	Yes	Yes	<b>Yes</b>	Yes
Digital Microphone Clock (DMIC_LR)	<b>Yes</b>	No	No	No	No
Digital Microphone Data (DMIC_DAT)	No	<b>Yes</b>	No	No	No
GPIO input (including jack/button detect)	Yes	Yes	Yes	Yes	Yes
MICBIAS Current detect output	Yes	Yes	Yes	Yes	Yes
MICBIAS Short Circuit detect output	Yes	Yes	Yes	Yes	Yes
FLL Lock output	Yes	Yes	Yes	Yes	Yes
FLL Clock output	Yes	Yes	Yes	Yes	Yes

**Table 71 GPIO Functions Available**

The register fields that control the functionality of these pins are described in Table 72. For each pin, the selected function is determined by the GPn\_FN field, where n identifies the GPIO pin (1 to 5). Note that the INTERRUPT pin is also referred to as GPIO4; the BCLK pin is also referred to as GPIO5.

The pin direction, set by GPn\_DIR, must be set according to the function selected by GPn\_FN.

The characteristics of any pin selected as an output may be controlled by setting GPn\_OP\_CFG - an output pin may be either CMOS or Open-Drain. When a pin is configured as a GPIO output, its level can be set to logic 0 or logic 1 using the GPn\_LVL field.

A pin configured as a GPIO input can be used to trigger an Interrupt event. This input may be configured as active high or active low using the GPn\_IP\_CFG field. De-bouncing of this input may be enabled using the GPn\_DB field. Internal pull-up and pull-down resistors may be enabled using the GPn\_PU and GPn\_PD fields. (Note that if GPn\_PU and GPn\_PD are both set for any GPIO pin, then the pull-up and pull-down will be disabled.)

Each of the GPIO pins is an input to the Interrupt control circuit and can be used to trigger an Interrupt event. The register field GPn\_INTMODE selects edge detect or level detect Interrupt functionality. Edge detect raises an interrupt on rising and falling transitions. Level detect asserts the interrupt for as long as the GPIO status is asserted. See "Interrupts".

The Digital Microphone Interface and MICBIAS Current Detect functions are described in the "Analogue Input Signal Path" section.

Interrupt Output is the default function of GPIO4. See "Interrupts" for further details.

BCLK is the default function of GPIO5. This may be input or output. Note that, when BCLK is enabled on this pin (GP5\_FN = 1h), the other GPIO control fields for this pin have no effect. When BCLK is not enabled on this pin (GP5\_FN ≠ 1h), the WM8903 uses the MCLK input as the Bit Clock. See "Digital Audio Interface Control" for further details.

REGISTER ADDRESS	BIT	LABEL	DEFAULT	DESCRIPTION
R116 (74h) GPIO Control 1	13:8	GP1_FN [5:0]	00_0000	GPIO 1 Pin Function select 00h = GPIO output 01h = Reserved 02h = IRQ output 03h = GPIO input 04h = MICBIAS Current detect 05h = MICBIAS Short Circuit detect 06h = DMIC_LR Clock output 07h = Reserved 08h = FLL Lock output 09h = FLL Clock output 0Ah to 3Fh = Reserved
	7	GP1_DIR	1	GPIO Pin Direction 0 = Output 1 = Input
	6	GP1_OP_CFG	0	Output pin configuration 0 = CMOS 1 = Open-drain
	5	GP1_IP_CFG	1	Input pin configuration 0 = Active low 1 = Active high
	4	GP1_LVL	0	GPIO Output Level (when GP1_FN = 00000) 0 = Logic 0 1 = Logic 1
	3	GP1_PD	1	GPIO Pull-Down Enable 0 = Pull-down disabled 1 = Pull-down enabled (Approx 100kΩ)
	2	GP1_PU	0	GPIO Pull-Up Enable 0 = Pull-up disabled 1 = Pull-up enabled (Approx 100kΩ)
	1	GP1_INTMODE	0	GPIO Interrupt Mode 0 = Level triggered 1 = Edge triggered
	0	GP1_DB	0	GPIO de-bounce 0 = GPIO is not debounced 1 = GPIO is debounced

REGISTER ADDRESS	BIT	LABEL	DEFAULT	DESCRIPTION
R117 (75h) GPIO Control 2	13:8	GP2_FN [5:0]	00_0000	GPIO 2 Pin Function select 00h = GPIO output 01h = Reserved 02h = IRQ output 03h = GPIO input 04h = MICBIAS Current detect 05h = MICBIAS Short Circuit detect 06h = DMIC_DAT Data input 07h = Reserved 08h = FLL Lock output 09h = FLL Clock output 0Ah to 3Fh = Reserved
	7	GP2_DIR	1	GPIO Pin Direction 0 = Output 1 = Input
	6	GP2_OP_CFG	0	Output pin configuration 0 = CMOS 1 = Open-drain
	5	GP2_IP_CFG	1	Input pin configuration 0 = Active low 1 = Active high
	4	GP2_LVL	0	GPIO Output Level (when GP2_FN = 00000) 0 = Logic 0 1 = Logic 1
	3	GP2_PD	1	GPIO Pull-Down Enable 0 = Pull-down disabled 1 = Pull-down enabled (Approx 100kΩ)
	2	GP2_PU	0	GPIO Pull-Up Enable 0 = Pull-up disabled 1 = Pull-up enabled (Approx 100kΩ)
	1	GP2_INTMODE	0	GPIO Interrupt Mode 0 = Level triggered 1 = Edge triggered
	0	GP2_DB	0	GPIO de-bounce 0 = GPIO is not debounced 1 = GPIO is debounced
R118 (76h) GPIO Control 3	13:8	GP3_FN [5:0]	00_0000	GPIO 3 Pin Function select 00h = GPIO output 01h = Reserved 02h = IRQ output 03h = GPIO input 04h = MICBIAS Current detect 05h = MICBIAS Short Circuit detect 06h = Reserved 07h = Reserved 08h = FLL Lock output 09h = FLL Clock output 0Ah to 3Fh = Reserved
	7	GP3_DIR	1	GPIO Pin Direction 0 = Output 1 = Input

REGISTER ADDRESS	BIT	LABEL	DEFAULT	DESCRIPTION
	6	GP3_OP_CFG	0	Output pin configuration 0 = CMOS 1 = Open-drain
	5	GP3_IP_CFG	1	Input pin configuration 0 = Active low 1 = Active high
	4	GP3_LVL	0	GPIO Output Level (when GP3_FN = 00000) 0 = Logic 0 1 = Logic 1
	3	GP3_PD	1	GPIO Pull-Down Enable 0 = Pull-down disabled 1 = Pull-down enabled (Approx 100kΩ)
	2	GP3_PU	0	GPIO Pull-Up Enable 0 = Pull-up disabled 1 = Pull-up enabled (Approx 100kΩ)
	1	GP3_INTMODE	0	GPIO Interrupt Mode 0 = Level triggered 1 = Edge triggered
	0	GP3_DB	0	GPIO de-bounce 0 = GPIO is not debounced 1 = GPIO is debounced
R119 (77h) GPIO Control 4	13:8	GP4_FN [5:0]	00_0010	GPIO 4 Pin Function select 00h = GPIO output 01h = Reserved 02h = IRQ output 03h = GPIO input 04h = MICBIAS Current detect 05h = MICBIAS Short Circuit detect 06h = Reserved 07h = Reserved 08h = FLL Lock output 09h = FLL Clock output 0Ah to 3Fh = Reserved
	7	GP4_DIR	0	GPIO Pin Direction 0 = Output 1 = Input
	6	GP4_OP_CFG	0	Output pin configuration 0 = CMOS 1 = Open-drain
	5	GP4_IP_CFG	1	Input pin configuration 0 = Active low 1 = Active high
	4	GP4_LVL	0	GPIO Output Level (when GP4_FN = 00000) 0 = Logic 0 1 = Logic 1
	3	GP4_PD	0	GPIO Pull-Down Enable 0 = Pull-down disabled 1 = Pull-down enabled (Approx 100kΩ)
	2	GP4_PU	0	GPIO Pull-Up Enable 0 = Pull-up disabled 1 = Pull-up enabled (Approx 100kΩ)

REGISTER ADDRESS	BIT	LABEL	DEFAULT	DESCRIPTION
	1	GP4_INTMODE	0	GPIO Interrupt Mode 0 = Level triggered 1 = Edge triggered
	0	GP4_DB	0	GPIO de-bounce 0 = GPIO is not debounced 1 = GPIO is debounced
R120 (78h) GPIO Control 5	13:8	GP5_FN [5:0]	00_0001	GPIO 5 Pin Function select 00h = GPIO output 01h = BCLK 02h = IRQ output 03h = GPIO input 04h = MICBIAS Current detect 05h = MICBIAS Short Circuit detect 06h = Reserved 07h = Reserved 08h = FLL Lock output 09h = FLL Clock output 0Ah to 3Fh = Reserved
	7	GP5_DIR	1	GPIO Pin Direction 0 = Output 1 = Input
	6	GP5_OP_CFG	0	Output pin configuration 0 = CMOS 1 = Open-drain
	5	GP5_IP_CFG	1	Input pin configuration 0 = Active low 1 = Active high
	4	GP5_LVL	0	GPIO Output Level (when GP5_FN = 00000) 0 = Logic 0 1 = Logic 1
	3	GP5_PD	0	GPIO Pull-Down Enable 0 = Pull-down disabled 1 = Pull-down enabled (Approx 100kΩ)
	2	GP5_PU	0	GPIO Pull-Up Enable 0 = Pull-up disabled 1 = Pull-up enabled (Approx 100kΩ)
	1	GP5_INTMODE	0	GPIO Interrupt Mode 0 = Level triggered 1 = Edge triggered
	0	GP5_DB	0	GPIO de-bounce 0 = GPIO is not debounced 1 = GPIO is debounced

Table 72 GPIO Control

**INTERRUPTS**

The Interrupt Controller has multiple inputs. These include the GPIO input pins and the MICBIAS current detection circuits. Any combination of these inputs can be used to trigger an Interrupt (IRQ) event.

There is an Interrupt Status field associated with each of the IRQ inputs. These are contained in the Interrupt Status Register (R121), as described in Table 73. The status of the IRQ inputs can be read from this register at any time, or else in response to the Interrupt Output being signalled via a GPIO pin.

The Interrupt Output represents the logical 'OR' of all the unmasked IRQ inputs. The bits within the Interrupt Status register (R121) are latching fields and, once they are set, they are not reset until the Status Register is read. Accordingly, the Interrupt Output is not reset until each of the unmasked IRQ inputs has been read. Note that, if the condition that caused the IRQ input to be asserted is still valid, then the Interrupt Output will remain set even after the Status register has been read.

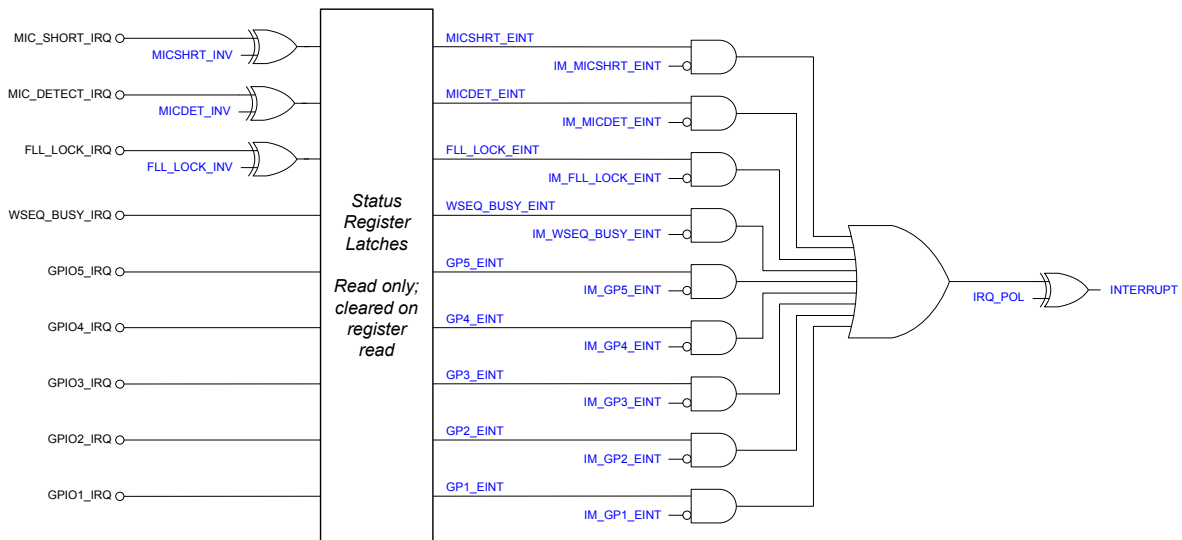
Each of the IRQ inputs can be individually masked or enabled as an input to the Interrupt function, using the bits contained in the Interrupt Status Mask register (R122). Note that the interrupt status fields remain valid, even when masked, but the masked bits will not cause the Interrupt Output to be asserted.

When a GPIO input is used as Interrupt event, the polarity can be set using GP\_IP\_CFG as described in Table 72. The polarity of the MICBIAS detection functions can be set using MICDET\_INV and MICSHRT\_INV as described in Table 73; this allows the IRQ event to be used to indicate either the removal or insertion of a microphone accessory. The polarity of the FLL Lock indication can be set using FLL\_LOCK\_INV; this allows the IRQ event to be used to indicate either the FLL Lock or the FLL Not-Locked status.

By default, the Interrupt Output is Active High. The polarity can be inverted using IRQ\_POL.

The Interrupt Output may be configured the INTERRUPT/GPIO4 pin or on the GPIO1/DMIC\_LR, GPIO2/DMIC\_DAT, GPIO3/ADDR or BCLK/GPIO5 pins. Interrupt Output is the default function on the INTERRUPT pin (GP4\_FN = 2h), but the INTERRUPT pin can also be used to support other functions. See "General Purpose Input/Output (GPIO)" for details of how to configure GPIO pins for Interrupt (IRQ) output.

The WM8903 Interrupt Controller circuit is illustrated in Figure 54. The associated control fields are described in Table 73.



**Figure 56** Interrupt Controller



REGISTER ADDRESS	BIT	LABEL	DEFAULT	DESCRIPTION
R121 (79h) Interrupt Status 1	15	MICSHRT_EINT	0	MICBIAS Short Circuit detect IRQ status 0 = Short Circuit current IRQ not set 1 = Short Circuit current IRQ set
	14	MICDET_EINT	0	MICBIAS Current detect IRQ status 0 = Current detect IRQ not set 1 = Current detect IRQ set
	13	WSEQ_BUSY_EINT	0	Write Sequencer Busy IRQ status 0 = WSEQ IRQ not set 1 = WSEQ IRQ set The Write Sequencer asserts this flag when it has completed a programmed sequence - ie it indicates that the Write Sequencer is NOT Busy.
	5	FLL_LOCK_EINT	0	FLL Lock IRQ status 0 = FLL Lock IRQ not set 1 = FLL Lock IRQ set
	4	GP5_EINT	0	GPIO5 IRQ status 0 = GPIO5 IRQ not set 1 = GPIO5 IRQ set
	3	GP4_EINT	0	GPIO4 IRQ status 0 = GPIO4 IRQ not set 1 = GPIO4 IRQ set
	2	GP3_EINT	0	GPIO3/ADDR IRQ status 0 = GPIO3 IRQ not set 1 = GPIO3 IRQ set
	1	GP2_EINT	0	GPIO2/DMIC_DAT IRQ status 0 = GPIO2 IRQ not set 1 = GPIO2 IRQ set
	0	GP1_EINT	0	GPIO1/DMIC_LR IRQ status 0 = GPIO1 IRQ not set 1 = GPIO1 IRQ set
R122 (7Ah) Interrupt Status 1 Mask	15	IM_MICSHRT_EINT	1	Interrupt mask for MICBIAS Short Circuit detect 0 = Not masked 1 = Masked
	14	IM_MICDET_EINT	1	Interrupt mask for MICBIAS Current detect 0 = Not masked 1 = Masked
	13	IM_WSEQ_BUSY_EINT	1	Interrupt mask for WSEQ Busy indication 0 = Not masked 1 = Masked
	5	IM_FLL_LOCK_EINT	1	Interrupt mask for FLL Lock 0 = Not masked 1 = Masked
	4	IM_GP5_EINT	1	Interrupt mask for GPIO5 0 = Not masked 1 = Masked
	3	IM_GP4_EINT	1	Interrupt mask for GPIO4 0 = Not masked 1 = Masked
	2	IM_GP3_EINT	1	Interrupt mask for GPIO3/ADDR 0 = Not masked 1 = Masked

REGISTER ADDRESS	BIT	LABEL	DEFAULT	DESCRIPTION
	1	IM_GP2_EINT	1	Interrupt mask for GPIO2/DMIC_DAT 0 = Not masked 1 = Masked
	0	IM_GP1_EINT	1	Interrupt mask for GPIO1/DMIC_LR 0 = Not masked 1 = Masked
R123 (7Bh) Interrupt Polarity 1	15	MICSHRT_INV	0	MICBIAS Short Circuit detect polarity 0 = Detect current increase above threshold 1 = Detect current decrease below threshold
	14	MICDET_INV	0	MICBIAS Current Detect polarity 0 = Detect current increase above threshold 1 = Detect current decrease below threshold
	5	FLL_LOCK_INV	0	FLL Lock polarity 0 = Non-inverted 1 = Inverted
R126 (7Eh) Interrupt Control	0	IRQ_POL	0	Interrupt Output polarity 0 = Active high 1 = Active low

Table 73 Interrupt Control

## CONTROL INTERFACE

The WM8903 is controlled by writing to registers through a 2-wire serial control interface. Readback is available for all registers, including Chip ID, power management status and GPIO status.

Note that, if it cannot be assured that MCLK is present when accessing the register map, then it is required to set CLK\_SYS\_ENA = 0 to ensure correct operation. See “Clocking and Sample Rates” for further details and for the definition of CLK\_SYS\_ENA.

The WM8903 is a slave device on the control interface; SCLK is a clock input, while SDIN is a bi-directional data pin. To allow arbitration of multiple slaves (and/or multiple masters) on the same interface, the WM8903 transmits logic 1 by tri-stating the SDIN pin, rather than pulling it high. An external pull-up resistor is required to pull the SDIN line high so that the logic 1 can be recognised by the master.

In order to allow many devices to share a single 2-wire control bus, every device on the bus has a unique 8-bit device ID (this is not the same as the 8-bit address of each register in the WM8903). The default device ID for the WM8903 is 0011 0100 (34h). The LSB of the device ID is the Read/Write bit; this bit is set to logic 1 for “Read” and logic 0 for “Write”.

Alternatively, the device ID can be set to 0011 0110 (0x36) by pulling the GPIO3/ADDR pin high during device start-up, when the internal power-on reset signal PORB (see “Power-on Reset”) is released. The setup and hold times for device ID selection are shown in Table 74. After the device ID has been selected, the GPIO3/ADDR pin can be used as a GPIO.

SYMBOL	MIN	TYP	MAX	UNIT
T <sub>psetup</sub>	100			µs
T <sub>puhold</sub>	100			µs

**Table 74 GPIO3/ADDR Latch on Power-up Timing**

The WM8903 operates as a slave device only. The controller indicates the start of data transfer with a high to low transition on SDIN while SCLK remains high. This indicates that a device ID, register address and data will follow. The WM8903 responds to the start condition and shifts in the next eight bits on SDIN (8-bit device ID, including Read/Write bit, MSB first). If the device ID received matches the device ID of the WM8903, then the WM8903 responds by pulling SDIN low on the next clock pulse (ACK). If the device ID is not recognised or the R/W bit is ‘1’ when operating in write only mode, the WM8903 returns to the idle condition and waits for a new start condition and valid address.

If the device ID matches the device ID of the WM8903, the data transfer continues as described below. The controller indicates the end of data transfer with a low to high transition on SDIN while SCLK remains high. After receiving a complete address and data sequence the WM8903 returns to the idle state and waits for another start condition. If a start or stop condition is detected out of sequence at any point during data transfer (i.e. SDIN changes while SCLK is high), the device returns to the idle condition.

The WM8903 supports the following read and write operations:

- Single write
- Single read
- Multiple write using auto-increment
- Multiple read using auto-increment

The sequence of signals associated with a single register write operation is illustrated in Figure 57.

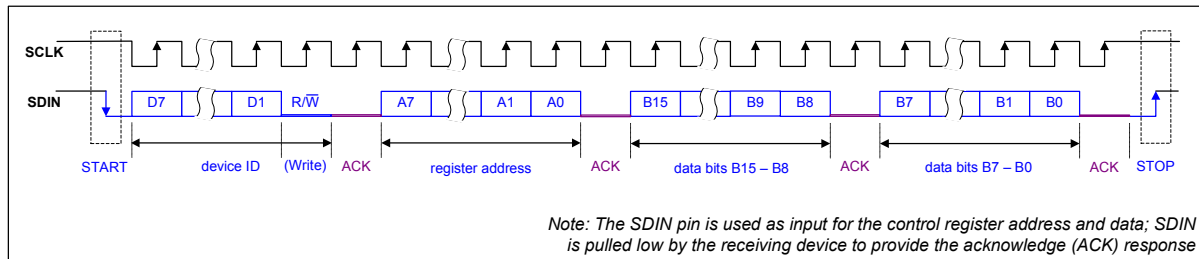


Figure 57 Control Interface Register Write

The sequence of signals associated with a single register read operation is illustrated in Figure 58.

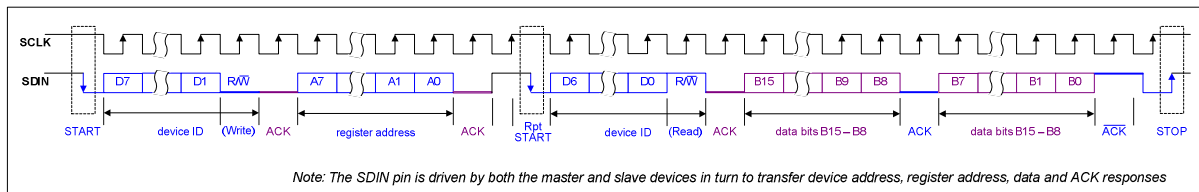


Figure 58 Control Interface Register Read

The Control Interface also supports other register operations, as listed above. The interface protocol for these operations is summarised below. The terminology used in the following figures is detailed in Table 75.

Note that multiple write and multiple read operations are supported using the auto-increment mode. This feature enables the host processor to access sequential blocks of the data in the WM8903 register map faster than is possible with single register operations.

TERMINOLOGY		DESCRIPTION
S		Start Condition
Sr		Repeated start
A		Acknowledge (SDIN Low)
$\bar{A}$		Not Acknowledge (SDIN High)
P		Stop Condition
R/W	ReadNotWrite	0 = Write 1 = Read
[White field]		Data flow from bus master to WM8903
[Grey field]		Data flow from WM8903 to bus master

Table 75 Control Interface Terminology

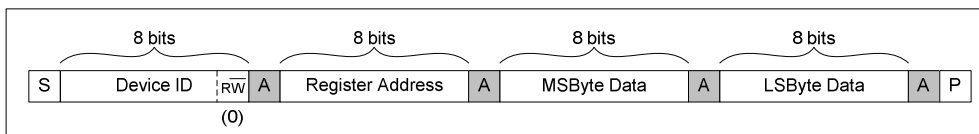


Figure 59 Single Register Write to Specified Address

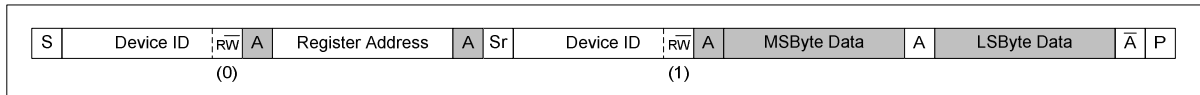


Figure 60 Single Register Read from Specified Address

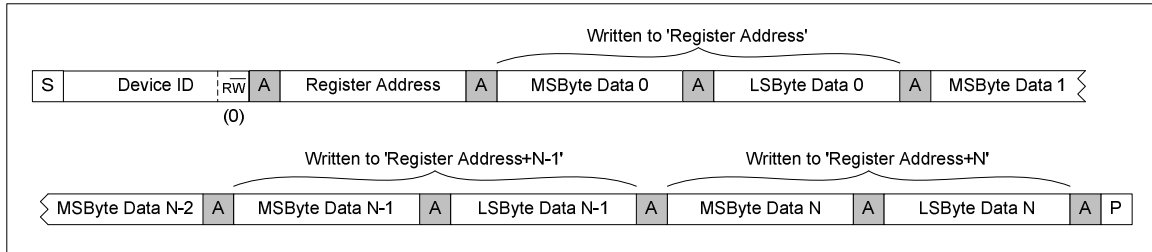


Figure 61 Multiple Register Write to Specified Address using Auto-increment

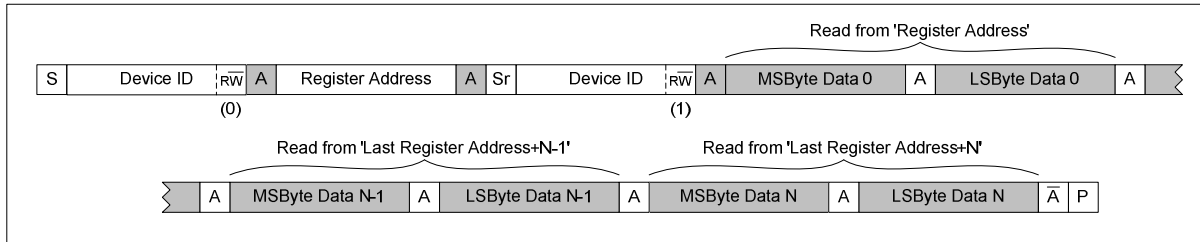


Figure 62 Multiple Register Read from Specified Address using Auto-increment

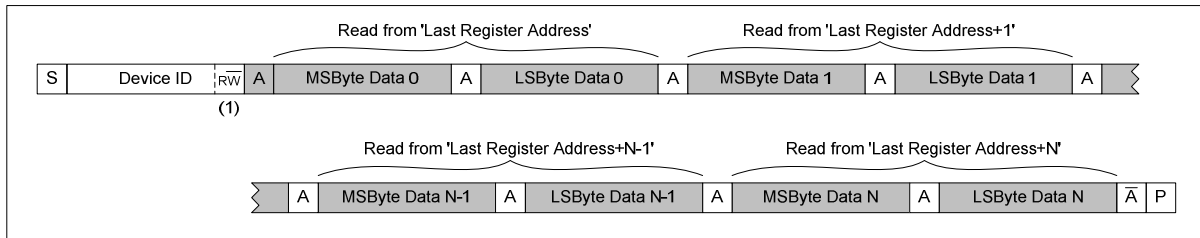


Figure 63 Multiple Register Read from Last Address using Auto-increment

## CONTROL WRITE SEQUENCER

The Control Write Sequencer is a programmable unit that forms part of the WM8903 control interface logic. It provides the ability to perform a sequence of register write operations with the minimum of demands on the host processor - the sequence may be initiated by a single operation from the host processor and then left to execute independently.

Default sequences for Start-Up and Shut-Down are provided (see "Default Sequences" section). It is recommended that these default sequences are used unless changes become necessary.

When a sequence is initiated, the sequencer performs a series of pre-defined register writes. The host processor informs the sequencer of the start index of the required sequence within the sequencer's memory. At each step of the sequence, the contents of the selected register fields are read from the sequencer's memory and copied into the WM8903 control registers. This continues sequentially through the sequencer's memory until an "End of Sequence" bit is encountered; at this point, the sequencer stops and an Interrupt status flag is asserted. For cases where the timing of the write sequence is important, a programmable delay can be set for specific steps within the sequence.

Note that the Control Write Sequencer's internal clock is derived from the internal clock CLK\_SYS. An external MCLK signal must be present when using the Control Write Sequencer, and CLK\_SYS must be enabled by setting CLK\_SYS\_ENA (see "Clocking and Sample Rates"). The clock division from MCLK is handled transparently by the WM8903 without user intervention, as long as MCLK and sample rates are set correctly.

### INITIATING A SEQUENCE

The Register fields associated with running the Control Write Sequencer are described in Table 76.

The Write Sequencer Clock is enabled by setting the WSMD\_CLK\_ENA bit. Note that the operation of the Control Write Sequencer also requires the internal clock CLK\_SYS to be enabled via the CLK\_SYS\_ENA (see "Clocking and Sample Rates").

The start index of the required sequence must be written to the WSEQ\_START\_INDEX field. Setting the WSEQ\_START bit initiates the sequencer at the given start index.

The Write Sequencer can be interrupted by writing a logic 1 to the WSEQ\_ABORT bit.

The current status of the Write Sequencer can be read using two further register fields - when the WSEQ\_BUSY bit is asserted, this indicates that the Write Sequencer is busy. Note that, whilst the Control Write Sequencer is running a sequence (indicated by the WSEQ\_BUSY bit), normal read/write operations to the Control Registers cannot be supported. (The Write Sequencer registers and the Software Reset register can still be accessed when the Sequencer is busy.) The index of the current step in the Write Sequencer can be read from the WSEQ\_CURRENT\_INDEX field; this is an indicator of the sequencer's progress. On completion of a sequence, this field holds the index of the last step within the last commanded sequence.

When the Write Sequencer reaches the end of a sequence, it asserts the WSEQ\_BUSY\_EINT flag in Register R121 (see Table 73 within the "Interrupts" section). This flag can be used to generate an Interrupt Event on completion of the sequence. Note that the WSEQ\_BUSY\_EINT flag is asserted to indicate that the WSEQ is NOT Busy.

REGISTER ADDRESS	BIT	LABEL	DEFAULT	DESCRIPTION
R108 (6Ch) Write Sequencer 0	8	WSMD_CLK_ENA	0	Write Sequencer / Mic Detect Clock Enable. 0 = Disabled 1 = Enabled
R111 (6Fh) Write Sequencer 3	9	WSEQ_ABORT	0	Writing a 1 to this bit aborts the current sequence and returns control of the device back to the serial control interface.
	8	WSEQ_START	0	Writing a 1 to this bit starts the write sequencer at the memory location indicated by the WSEQ_START_INDEX field. The sequence continues until it reaches an "End of sequence" flag. At the end of the sequence, this bit will be reset by the Write Sequencer.
	5:0	WSEQ_START_INDEX [5:0]	00_0000	Sequence Start Index. This is the memory location of the first command in the selected sequence. 0 to 31 = RAM addresses 32 to 48 = ROM addresses 49 to 63 = Reserved
R112 (70h) Write Sequencer 4	9:4	WSEQ_CURRENT_INDEX [5:0]	00_0000	Sequence Current Index. This is the location of the most recently accessed command in the write sequencer memory.
	0	WSEQ_BUSY	0	Sequencer Busy flag (Read Only). 0 = Sequencer idle 1 = Sequencer busy Note: it is not possible to write to control registers via the control interface while the Sequencer is Busy.

Table 76 Write Sequencer Control – Initiating a Sequence

### PROGRAMMING A SEQUENCE

A sequence consists of write operations to data bits (or groups of bits) within the control registers. The Register fields associated with programming the Control Write Sequencer are described in Table 77.

For each step of the sequence being programmed, the Sequencer Index must be written to the WSEQ\_WRITE\_INDEX field. The values 0 to 31 correspond to all the available RAM addresses within the Write Sequencer memory. (Note that memory addresses 32 to 48 also exist, but these are ROM addresses, which are not programmable.)

Having set the Index as described above, Register R109 must be written to (containing the Control Register Address, the Start Bit Position and the Field Width applicable to this step of the sequence). Also, Register R110 must be written to (containing the Register Data, the End of Sequence flag and the Delay time required after this step is executed). After writing to these two registers, the next step in the sequence may be programmed by updating WSEQ\_WRITE\_INDEX and repeating the procedure.

WSEQ\_ADDR is an 8-bit field containing the Control Register Address in which the data should be written.

WSEQ\_DATA\_START is a 4-bit field which identifies the LSB position within the selected Control Register to which the data should be written. Setting WSEQ\_DATA\_START = 0100 will cause 1-bit data to be written to bit 4. With this setting, 4-bit data would be written to bits 7:4 and so on.

WSEQ\_DATA\_WIDTH is a 3-bit field which identifies the width of the data block to be written. This enables selected portions of a Control Register to be updated without any concern for other bits within the same register, eliminating the need for read-modify-write procedures. Values of 0 to 7 correspond to data widths of 1 to 8 respectively. For example, setting WSEQ\_DATA\_WIDTH = 010 will cause a 3-bit data block to be written. Note that the maximum value of this field corresponds to an 8-bit data block; writing to register fields greater than 8 bits wide must be performed using two separate operations of the Control Write Sequencer.

WSEQ\_DATA is an 8-bit field which contains the data to be written to the selected Control Register. The WSEQ\_DATA\_WIDTH field determines how many of these bits are written to the selected register; the most significant bits (above the number indicated by WSEQ\_DATA\_WIDTH) are ignored.

WSEQ\_DELAY is a 4-bit field which controls the waiting time between the current step and the next step in the sequence. The total delay time per step (including execution) is given by:

$$T = k \times (2^{WSEQ\_DELAY} + 8)$$

where  $k = 62.5\mu\text{s}$  (under recommended operating conditions)

This gives a useful range of execution/delay times from  $562\mu\text{s}$  up to 2.048s per step.

WSEQ\_EOS is a 1-bit field which indicates the End of Sequence. If this bit is set, then the Control Write Sequencer will automatically stop after this step has been executed.

REGISTER ADDRESS	BIT	LABEL	DEFAULT	DESCRIPTION
R108 (6Ch) Write Sequencer 0	4:0	WSEQ_WRIT E_INDEX [4:0]	0_0000	Sequence Write Index. This is the memory location to which any updates to R109 and R110 will be copied. 0 to 31 = RAM addresses
R109 (6Dh) Write Sequencer 1	14:12	WSEQ_DATA _WIDTH [2:0]	000	Width of the data block written in this sequence step. 000 = 1 bit 001 = 2 bits 010 = 3 bits 011 = 4 bits 100 = 5 bits 101 = 6 bits 110 = 7 bits 111 = 8 bits
	11:8	WSEQ_DATA _START [3:0]	0000	Bit position of the LSB of the data block written in this sequence step. 0000 = Bit 0 ... 1111 = Bit 15
	7:0	WSEQ_ADDR [7:0]	0000_0000	Control Register Address to be written to in this sequence step.
R110 (6Eh) Write Sequencer 2	14	WSEQ_EOS	0	End of Sequence flag. This bit indicates whether the Control Write Sequencer should stop after executing this step. 0 = Not end of sequence 1 = End of sequence (Stop the sequencer after this step).
	11:8	WSEQ_DELA Y [3:0]	0000	Time delay after executing this step. Total time per step (including execution) = $62.5\mu\text{s} \times (2^{WSEQ\_DELAY} + 8)$
	7:0	WSEQ_DATA [7:0]	0000_0000	Data to be written in this sequence step. When the data width is less than 8 bits, then one or more of the MSBs of WSEQ_DATA are ignored. It is recommended that unused bits be set to 0.

Table 77 Write Sequencer Control - Programming a Sequence



Note that a 'Dummy' write can be inserted into a control sequence by commanding the sequencer to write a value of 0 to bit 0 of Register R255 (FFh). This is effectively a write to a non-existent register location. This can be used in order to create placeholders ready for easy adaptation of the sequence. For example, a sequence could be defined to power-up a mono signal path from DACL to headphone, with a 'dummy' write included to leave space for easy modification to a stereo signal path configuration. Dummy writes can also be used in order to implement additional time delays between register writes. Dummy writes are included in the default start-up sequence – see Table 79.

In summary, the Control Register to be written is set by the WSEQ\_ADDR field. The data bits that are written are determined by a combination of WSEQ\_DATA\_START, WSEQ\_DATA\_WIDTH and WSEQ\_DATA. This is illustrated below for an example case of writing to the VMID\_RES field within Register R5 (05h).

In this example, the Start Position is bit 01 (WSEQ\_DATA\_START = 0001b) and the Data width is 2 bits (WSEQ\_DATA\_WIDTH = 0001b). With these settings, the Control Write Sequencer would update the Control Register R5 [2:1] with the contents of WSEQ\_DATA [1:0].

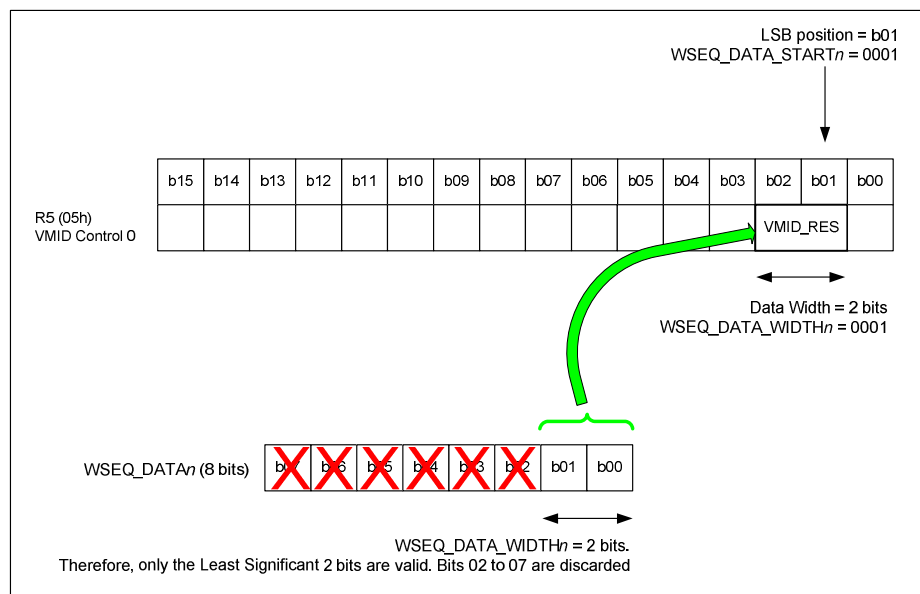


Figure 64 Control Write Sequencer Example

**DEFAULT SEQUENCES**

When the WM8903 is powered up, two Control Write Sequences are available through default settings in both RAM and ROM memory locations. The purpose of these sequences, and the register write required to initiate them, is summarised in Table 78. In both cases, a single register write will initiate the sequence.

WSEQ START INDEX	WSEQ FINISH INDEX	PURPOSE	TO INITIATE
0 (00h)	29 (1Dh)	Start-Up sequence	Write 0100h to Register R111 (6Fh)
32 (20h)	48 (30h)	Shutdown sequence	Write 0120h to Register R111 (6Fh)

Table 78 Write Sequencer Default Sequences

Note on Shut-Down sequence: The instruction at Index Address 32 (20h) shorts the outputs LINEOUTL and LINEOUTR. If the Line outputs are not in use at the time the sequence is run, then the sequence could, instead, be started at Index Address 33.

Index addresses 0 to 31 may be programmed to users' own settings at any time, as described in "Programming a Sequence" Users' own settings remain in memory and are not affected by software resets (i.e. writing to Register R0). However, any non-default sequences are lost when the device is powered down.

### START-UP SEQUENCE

The Start-up sequence is initiated by writing 0100h to Register R111 (6Fh). This single operation starts the Control Write Sequencer at Index Address 0 (00h) and executes the sequence defined in Table 79.

For typical clocking configurations with MCLK=12.288MHz, this sequence takes approximately 425ms to run.

WSEQ INDEX	REGISTER ADDRESS	WIDTH	START	DATA	DELAY	EOS	DESCRIPTION
0 (00h)	R4 (04h)	5 bits	Bit 0	1Ah	0h	0b	POBCTRL = 1 ISEL [1:0] = 10b STARTUP_BIAS_ENA = 1 BIAS_ENA = 0 (delay = 0.5625ms)
1 (01h)	R65 (41h)	1 bit	Bit 1	01h	9h	0b	SPK_DISCHARGE = 1 (delay = 32.5ms)
2 (02h)	R17 (11h)	2 bits	Bit 0	03h	0h	0b	SPKL_ENA = 1 SPKR_ENA = 1 (delay = 0.5625ms)
3 (03h)	R65 (41h)	1 bit	Bit 1	00h	0h	0b	SPK_DISCHARGE = 0 (delay = 0.5625ms)
4 (04h)	R5 (5h)	8 bits	Bit 0	F7h	Bh	0b	VMID_TIE_ENA = 1 BUFIO_ENA = 1 VMID_IO_ENA = 1 VMID_SOFT = 10 VMID_RES = 11 VMID_BUF_ENA = 1 (delay = 128.5ms)
5 (05h)	R17 (11h)	2 bits	Bit 0	00h	0h	0b	SPKL_ENA = 0 SPKR_ENA = 0 (delay = 0.5625ms)
6 (06h)	R5 (5h)	2 bits	Bit 3	00h	0h	0b	VMID_SOFT = 00 (delay = 0.5625ms)
7 (07h)	R5 (05h)	2 bits	Bit 1	01h	0h	0b	VMID_RES [1:0] = 01b (delay = 0.5625ms)
8 (08h)	R4 (04h)	1 bit	Bit 0	01h	0h	0b	BIAS_ENA = 1 (delay = 0.5625ms)
9 (09h)	R14 (0Eh)	2 bits	Bit 0	03h	0h	0b	HPL_PGA_ENA = 1 HPR_PGA_ENA = 1 (delay = 0.5625ms)
10 (0Ah)	R13 (Dh)	2 bits	Bit 0	03h	0h	0b	MIXOUTL = 1 MIXOUTR = 1 (delay = 0.5625ms)
11 (0Bh)	R15 (0Fh)	2 bits	Bit 0	03h	0h	0b	LINEOUTL_PGA_ENA = 1 LINEOUTR_PGA_ENA = 1 (delay = 0.5625ms)
12 (0Ch)	R22 (16h)	1 bit	Bit 1	01h	0h	0b	CLK_DSP_ENA = 1 (delay = 0.5625ms)

WSEQ INDEX	REGISTER ADDRESS	WIDTH	START	DATA	DELAY	EOS	DESCRIPTION
13 (0Dh)	R18 (12h)	2 bits	Bit 2	03h	5h	0b	DACL_ENA = 1 DACR_ENA = 1 (delay = 2.5ms)
14 (0Eh)	R255 (FFh)	1 bit	Bit 0	00h	0h	0b	Dummy Write for expansion (delay = 0.5625ms)
15 (0Fh)	R4 (04h)	1 bit	Bit 4	00h	0h	0b	POBCTRL = 0 (delay = 0.5625ms)
16 (10h)	R98 (62h)	1 bit	Bit 0	01h	6h	0b	CP_ENA = 1 (delay = 4.5ms)
17 (11h)	R255 (FFh)	1 bit	Bit 0	00h	0h	0b	Dummy Write for expansion (delay = 0.5625ms)
18 (12h)	R90 (5Ah)	8 bits	Bit 0	11h	0h	0b	HPL_ENA = 1 HPR_ENA = 1 (delay = 0.5625ms)
19 (13h)	R94 (5Eh)	8 bits	Bit 0	11h	0h	0b	LINEOUTL_ENA = 1 LINEOUTR_ENA = 1 (delay = 0.5625ms)
20 (14h)	R90 (5Ah)	8 bits	Bit 0	33h	0h	0b	HPL_ENA_DLY = 1 HPR_ENA_DLY = 1 (delay = 0.5625ms)
21 (15h)	R94 (5Eh)	8 bits	Bit 0	33h	0h	0b	LINEOUTL_ENA_DLY = 1 LINEOUTR_ENA_DLY = 1 (delay = 0.5625ms)
22 (16h)	R69 (45h)	2 bits	Bit 0	02h	0h	0b	DCS_MODE = 10 (delay = 0.5625ms)
23 (17h)	R67 (43h)	4 bits	Bit 0	0Fh	Ch	0b	DCS_ENA = 1111 (delay = 256.5ms)
24 (18h)	R67 (43h)	4 bits	Bit 0	0Fh	7h	0b	DCS_ENA = 1111 (delay = 8.5ms)
25 (19h)	R255 (FFh)	1 bit	Bit 0	00h	0h	0b	Dummy Write for expansion (delay = 0.5625ms)
26 (1Ah)	R90 (5Ah)	8 bits	Bit 0	77h	0h	0b	HPL_ENA_OUTP = 1 HPR_ENA_OUTP = 1 (delay = 0.5625ms)
27 (1Bh)	R94 (5Eh)	8 bits	Bit 0	77h	0h	0b	LINEOUTL_ENA_OUTP = 1 LINEOUTR_ENA_OUTP = 1 (delay = 0.5625ms)
28 (1Ch)	R90 (5Ah)	8 bits	Bit 0	FFh	0h	0b	HPL_RMV_SHORT = 1 HPR_RMV_SHORT = 1 (delay = 0.5625ms)
29 (1Dh)	R94 (5Eh)	8 bits	Bit 0	FFh	0h	1b	LINEOUTL_RMV_SHORT = 1 LINEOUTR_RMV_SHORT = 1 End of Sequence
30 (1Eh)	R255 (FFh)	1 bit	Bit 0	00h	0h	0b	Spare
31 (1Fh)	R255 (FFh)	1 bit	Bit 0	00h	0h	0b	Spare

Table 79 Start-up Sequence

**SHUTDOWN SEQUENCE**

The Shutdown sequence is initiated by writing 0120h to Register R111 (6Fh). This single operation starts the Control Write Sequencer at Index Address 32 (20h) and executes the sequence defined in Table 80.

For typical clocking configurations with MCLK=12.288MHz, this sequence takes approximately 325ms to run.

WSEQ INDEX	REGISTER ADDRESS	WIDTH	START	DATA	DELAY	EOS	DESCRIPTION
32 (20h)	R94 (5Eh)	8 bits	Bit 0	77h	0h	0b	LINEOUTL_RMV_SHORT = 0 LINEOUTR_RMV_SHORT = 0 (delay = 0.5625ms)
33 (21h)	R90 (5Ah)	8 bits	Bit 0	77h	0h	0b	HPL_RMV_SHORT = 0 HPR_RMV_SHORT = 0 (delay = 0.5625ms)
34 (22h)	R90 (5Ah)	8 bits	Bit 0	00h	0h	0b	HPL_ENA_OUTP = 0 HPL_ENA_DLY = 0 HPL_ENA = 0 HPR_ENA_OUTP = 0 HPR_ENA_DLY = 0 HPR_ENA = 0 (delay = 0.5625ms)
35 (23h)	R94 (5Eh)	8 bits	Bit 0	00h	0h	0b	LINEOUTL_ENA_OUTP = 0 LINEOUTL_ENA_DLY = 0 LINEOUTL_ENA = 0 LINEOUTR_ENA_OUTP = 0 LINEOUTR_ENA_DLY = 0 LINEOUTR_ENA = 0 (delay = 0.5625ms)
36 (24h)	R67 (43h)	4 bits	Bit 0	00h	0h	0b	DCS_ENA = 0000 (delay = 0.5625ms)
37 (25h)	R98 (62h)	1 bit	Bit 0	00h	0h	0b	CP_ENA = 0 (delay = 0.5625ms)
38 (26h)	R18 (12h)	2 bits	Bit 2	00h	0h	0b	DACL_ENA = 0 DACR_ENA = 0 (delay = 0.5625ms)
39 (27h)	R22 (16h)	1 bit	Bit 1	00h	0h	0b	CLK_DSP_ENA = 0 (delay = 0.5625ms)
40 (28h)	R14 (0Eh)	2 bits	Bit 0	00h	0h	0b	HPL_PGA_ENA = 0 HPR_PGA_ENA = 0 (delay = 0.5625ms)
41 (29h)	R15 (0Fh)	2 bits	Bit 0	00h	0h	0b	LINEOUTL_PGA_ENA = 0 LINEOUTR_PGA_ENA = 0 (delay = 0.5625ms)
42 (2Ah)	R13 (0Dh)	2 bits	Bit 0	00h	0h	0b	MIXOUTL_ENA = 0 MIXOUTR_ENA = 0 (delay = 0.5625ms)
43 (2Bh)	R4 (04h)	1 bit	Bit 0	00h	0h	0b	BIAS_ENA = 0 (delay = 0.5625ms)
44 (2Ch)	R5 (05h)	2 bits	Bit 3	02h	0h	0b	VMID_SOFT = 10 (delay = 0.5625ms)
45 (2Dh)	R5 (05h)	1 bit	Bit 0	00h	Ch	0b	VMID_BUF_ENA = 0 (delay = 256.5ms)
46 (2Eh)	R5 (05h)	1 bit	Bit 0	00h	9h	0b	VMID_BUF_ENA = 0 (delay = 32.5ms)

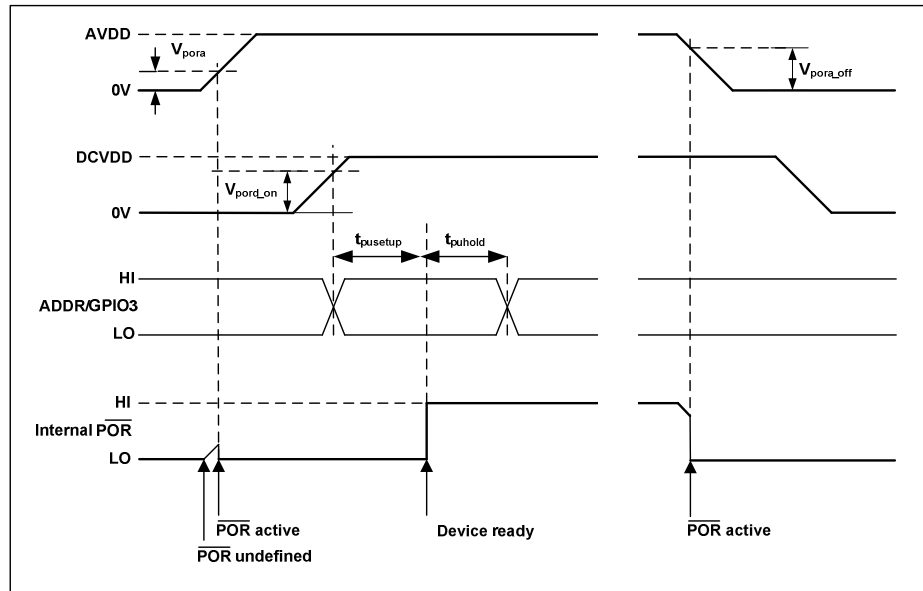
WSEQ INDEX	REGISTER ADDRESS	WIDTH	START	DATA	DELAY	EOS	DESCRIPTION
47 (2Fh)	R5 (05h)	8 bits	Bit 0	00h	0h	0b	VMID_TIE_ENA = 0 BUFIO_ENA = 0 VMID_IO_ENA = 0 VMID_SOFT = 00 VMID_RES = 00 VMID_BUF_ENA = 0 (delay = 0.5625ms)
48 (30h)	R4 (04h)	2 bits	Bit 0	00h	0h	1b	STARTUP_BIAS_ENA = 0 BIAS_ENA = 0 End of Sequence

Table 80 Shutdown Sequence

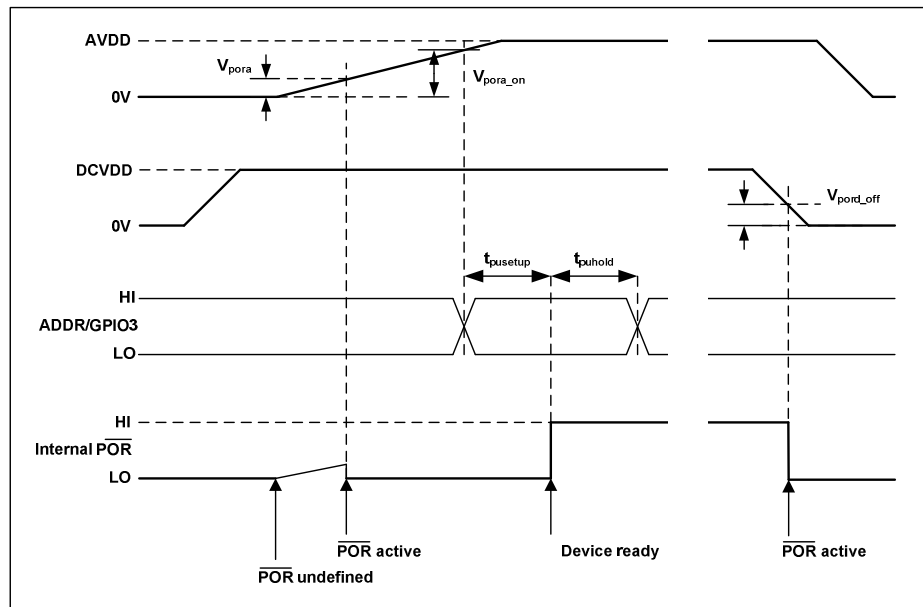
**POWER-ON RESET**

The WM8903 includes an internal Power-On-Reset (POR) circuit, which is used to reset the digital logic into a default state after power up. The POR circuit is powered from AVDD and monitors DCVDD. The internal POR signal is asserted low when AVDD or DCVDD are below minimum thresholds.

The specific behaviour of the circuit will vary, depending on the relative timing of the supply voltages. Typical scenarios are illustrated in Figure 65 and Figure 66.



**Figure 65 Power On Reset timing - AVDD enabled first**



**Figure 66 Power On Reset timing - DCVDD enabled first**

The POR signal is undefined until AVDD has exceeded the minimum threshold,  $V_{pora}$ . Once this threshold has been exceeded, POR is asserted low and the chip is held in reset. In this condition, all writes to the control interface are ignored. Once AVDD and DCVDD have reached their respective power on thresholds, POR is released high, all registers are in their default state, and writes to the control interface may take place.

Note that a minimum power-on reset period,  $T_{POR}$ , applies even if AVDD and DCVDD have zero rise time. (This specification is guaranteed by design rather than test.)

On power down, POR is asserted low when any of AVDD or DCVDD falls below their respective power-down thresholds.

Typical Power-On Reset parameters for the WM8903 are defined in Table 81.

SYMBOL	DESCRIPTION	TYP	UNIT
$V_{pora}$	AVDD threshold below which POR is undefined	0.5	V
$V_{pora\_on}$	Power-On threshold (AVDD)	1.15	V
$V_{pora\_off}$	Power-Off threshold (AVDD)	1.12	V
$V_{pord\_on}$	Power-On threshold (DCVDD)	0.57	V
$V_{pord\_off}$	Power-Off threshold (DCVDD)	0.56	V
$T_{POR}$	Minimum Power-On Reset period	10.6	$\mu$ S

**Table 81 Typical Power-On Reset parameters**

**Notes:**

1. If AVDD and DCVDD suffer a brown-out (i.e. drop below the minimum recommended operating level but do not go below  $V_{pora\_off}$  or  $V_{pord\_off}$ ) then the chip does not reset and resumes normal operation when the voltage is back to the recommended level again.
2. The chip enters reset at power down when AVDD or DCVDD falls below  $V_{pora\_off}$  or  $V_{pord\_off}$ . This may be important if the supply is turned on and off frequently by a power management system.
3. The minimum  $t_{por}$  period is maintained even if DCVDD and AVDD have zero rise time. This specification is guaranteed by design rather than test.
4. See "Control Interface" section for details of  $t_{pusetup}$  and  $t_{puhold}$ .

## QUICK START-UP AND SHUTDOWN

The WM8903 has the capability to perform a quick start-up and shut-down with a minimum number of register operations. This is achieved using the Control Write Sequencer, which is configured with default start-up settings that set up the device for DAC playback via Headphone and Line Output. Assuming a 12.288MHz external clock, the start-up sequence configures the device for 48kHz playback mode.

The default start-up sequence requires three register write operations. The default shutdown sequence requires just a single register write. The minimum procedure for executing the quick start-up and shutdown sequences is described below. See "Control Write Sequencer" for more details.

### QUICK START-UP (DEFAULT SEQUENCE)

An external clock must be applied to MCLK. Assuming 12.288MHz input clock, the start-up sequence will take approximately 425ms to complete.

The following register operations will initiate the quick start-up sequence.

REGISTER ADDRESS	VALUE	DESCRIPTION
R108 (6Ch) Write Sequencer 0	0100h	WSMD_CLK_ENA = 1 This enables the Write Sequencer Clock
R22 (16h) Clock Rates 2	0004h	CLK_SYS_ENA = 1 This enables the System Clock
R111 (6Fh) Write Sequencer 3	0100h	WSEQ_START_INDEX = 00h WSEQ_START = 1 WSEQ_ABORT = 0 This starts the Write Sequencer at Index address 0 (00h)

**Table 82 Quick Start-Up Control**

The WSEQ\_BUSY bit (in Register R112, see Table 76) will be set to 1 while the sequence runs. When this bit returns to 0, the device has been set up and is ready for DAC playback operation.

### QUICK SHUTDOWN (DEFAULT SEQUENCE)

The default shutdown sequence assumes the initial device conditions are as configured by the default start-up sequence. Assuming 12.288MHz input clock, the shutdown sequence will take approximately 325ms to complete.

The following register operation will initiate the default shut-down sequence.

REGISTER ADDRESS	VALUE	DESCRIPTION
R111 (6Fh) Write Sequencer 3	0120h	WSEQ_START_INDEX = 20h WSEQ_START = 1 WSEQ_ABORT = 0 This starts the Write Sequencer at Index address 32 (20h)

**Table 83 Quick Shutdown Control**

The WSEQ\_BUSY bit (in Register R112, see Table 76) will be set to 1 while the sequence runs. When this bit returns to 0, the system clock can be disabled (CLK\_SYS\_ENA=0) and MCLK can be stopped.



## SOFTWARE RESET AND CHIP ID

A Software Reset can be commanded by writing to Register R0. This is a read-only register field and the contents will not be affected by writing to this Register.

The Chip ID can be read back from Register R0. The Chip Revision ID can be read back from Register 1, as described in Table 84.

REGISTER ADDRESS	BIT	LABEL	DEFAULT	DESCRIPTION
R0 (00h) SW Reset and ID	15:0	SW_RST_DE C_ID1 [15:0]	8903h	Writing to this register resets all registers to their default state. Reading from this register will indicate Device ID 8903h.
R1 (01h) Revision Number	3:0	CHIP_REV [3:0]	0010b	Reading from this register will indicate the Revision ID.

**Table 84 Software Reset and Chip ID**

REGISTER MAP

Dec Addr	Hex Addr	Name	15	14	13	12	11	10	9	8	7	6	5	4	3	2	1	0	Bin Default
0		SW Reset and ID								SW_RST_DEV_ID[16:0]								1000_1001_0000_0011	
1	01	Revision Number	0	0	0	0	0	0	0	0	0	0	0	0	0	0	0	0000_0000_0000_0000	
4	04	Bias Control 0	0	0	0	0	0	0	0	0	0	0	0	POBCTRL	ISEL[1:0]	CHP_REV[0:0]	STARTUP_BIAS_ENA	BIAS_ENA	
5	05	VMD Control 0	0	0	0	0	0	0	0	0	VMD_TIE_ENA	BIUF0_ENA	VMD_IO_ENA	VMD_SOFT[1:0]	VMD_RES[0:0]	VMD_BUF_ENA	VMD_BIAS_ENA		
6	06	Mic Bias Control 0	0	0	0	0	0	0	0	0	0	0	0	MCDET_THR[0:0]	MCISORT_THR[0:0]	MCDET_ENA	MICBIAS_ENA		
8	08	Analogue DAC 0	0	0	0	0	0	0	0	0	0	0	0	0	0	0	0	0000_0000_0000_0001	
10	0A	Analogue ADC 0	0	0	0	0	0	0	0	0	0	0	0	0	0	0	0	0000_0000_0000_0001	
12	0C	Power Management 0	0	0	0	0	0	0	0	0	0	0	0	0	0	0	0	0000_0000_0000_0000	
13	0D	Power Management 1	0	0	0	0	0	0	0	0	0	0	0	0	0	0	0	0000_0000_0000_0000	
14	0E	Power Management 2	0	0	0	0	0	0	0	0	0	0	0	0	0	0	0	0000_0000_0000_0000	
15	0F	Power Management 3	0	0	0	0	0	0	0	0	0	0	0	0	0	0	0	0000_0000_0000_0000	
16	10	Power Management 4	0	0	0	0	0	0	0	0	0	0	0	0	0	0	0	0000_0000_0000_0000	
17	11	Power Management 5	0	0	0	0	0	0	0	0	0	0	0	0	0	0	0	0000_0000_0000_0000	
18	12	Power Management 6	0	0	0	0	0	0	0	0	0	0	0	0	0	0	0	0000_0000_0000_0000	
20	14	Clock Rates 0	0	0	0	0	0	0	0	0	0	0	0	0	0	0	0	0000_0100_0000_0000	
21	15	Clock Rates 1	0	0	0	0	0	0	0	0	0	0	0	0	0	0	0	0000_1100_0000_1000	
22	16	Clock Rates 2	0	0	0	0	0	0	0	0	0	0	0	0	0	0	0	0000_0000_0000_0000	
24	18	Auto Interface 0	0	0	0	0	0	0	0	0	0	0	0	0	0	0	0	0000_0000_0101_0000	
25	19	Auto Interface 1	0	0	0	0	0	0	0	0	0	0	0	0	0	0	0	0000_0000_0000_0010	
26	1A	Auto Interface 2	0	0	0	0	0	0	0	0	0	0	0	0	0	0	0	0000_0000_0000_1000	
27	1B	Auto Interface 3	0	0	0	0	0	0	0	0	0	0	0	0	0	0	0	0000_0000_0101_0010	
30	1E	DAC Digital Volume Left	0	0	0	0	0	0	0	0	0	0	0	0	0	0	0	0000_0000_1100_0000	
31	1F	DAC Digital Volume Right	0	0	0	0	0	0	0	0	0	0	0	0	0	0	0	0000_0000_1100_0000	
32	20	DAC Digital 0	0	0	0	0	0	0	0	0	0	0	0	0	0	0	0	0000_0000_0000_0000	
33	21	DAC Digital 1	0	0	0	0	0	0	0	0	0	0	0	0	0	0	0	0000_0000_0000_0000	
36	24	ADC Digital Volume Left	0	0	0	0	0	0	0	0	0	0	0	0	0	0	0	0000_0000_1100_0000	
37	25	ADC Digital Volume Right	0	0	0	0	0	0	0	0	0	0	0	0	0	0	0	0000_0000_1100_0000	
38	26	ADC Digital 0	0	0	0	0	0	0	0	0	0	0	0	0	0	0	0	0000_0000_0001_0000	

Dec Adtr	Hex Adtr	Name	15	14	13	12	11	10	9	8	7	6	5	4	3	2	1	0	Bin Default
40	DRC 0	DRC_EMA	0	0	0	DRC_THRESH_HYST[1:0]	0	0	0	0	0	0	0	0	DRC_SMOOTL_EMA	DRC_DR_EMA	DRC_ANTICLIP_EMA	DRC_HYST_EMA	0000_1001_1011_1111
41	DRC 1	DRC_ATTACK_RATE[0:3]	0	0	0	0	0	0	0	0	0	0	0	0	0	0	0	0	0011_0010_0100_0001
42	DRC 2	DRC_AMP_COMP[2:3]	0	0	0	0	0	0	0	0	0	0	0	0	0	0	0	0	0000_0000_0010_0000
43	DRC 3	DRC_THRESH_COMP[0:3]	0	0	0	0	0	0	0	0	0	0	0	0	0	0	0	0	0000_0000_0000_0000
44	2C	Analogue Left Input 0	0	0	0	0	0	0	0	0	0	0	0	0	0	0	0	0	0000_0000_1000_0101
45	2D	Analogue Right Input 0	0	0	0	0	0	0	0	0	0	0	0	0	0	0	0	0	0000_0000_1000_0101
46	2E	Analogue Left Input 1	0	0	0	0	0	0	0	0	0	0	0	0	0	0	0	0	0000_0000_0100_0100
47	2F	Analogue Right Input 1	0	0	0	0	0	0	0	0	0	0	0	0	0	0	0	0	0000_0000_0100_0100
50	32	Analogue Left Mix 0	0	0	0	0	0	0	0	0	0	0	0	0	0	0	0	0	0000_0000_0000_1000
51	33	Analogue Right Mix 0	0	0	0	0	0	0	0	0	0	0	0	0	0	0	0	0	0000_0000_0000_1000
52	34	Analogue SpkMix Left 0	0	0	0	0	0	0	0	0	0	0	0	0	0	0	0	0	0000_0000_0000_0000
53	35	Analogue SpkMix Left 1	0	0	0	0	0	0	0	0	0	0	0	0	0	0	0	0	0000_0000_0000_0000
54	36	Analogue SpkMix Right 0	0	0	0	0	0	0	0	0	0	0	0	0	0	0	0	0	0000_0000_0000_0000
55	37	Analogue SpkMix Right 1	0	0	0	0	0	0	0	0	0	0	0	0	0	0	0	0	0000_0000_0000_0000
57	39	Analogue OUT1 Left	0	0	0	0	0	0	0	0	0	0	0	0	0	0	0	0	0000_0000_P10_1101
58	3A	Analogue OUT1 Right	0	0	0	0	0	0	0	0	0	0	0	0	0	0	0	0	0000_0000_P10_1101
59	3B	Analogue OUT2 Left	0	0	0	0	0	0	0	0	0	0	0	0	0	0	0	0	0000_0000_P11_1011
60	3C	Analogue OUT2 Right	0	0	0	0	0	0	0	0	0	0	0	0	0	0	0	0	0000_0000_P11_1011
62	3E	Analogue OUT3 Left	0	0	0	0	0	0	0	0	0	0	0	0	0	0	0	0	0000_0001_P11_1011
63	3F	Analogue OUT3 Right	0	0	0	0	0	0	0	0	0	0	0	0	0	0	0	0	0000_0001_P11_1011
65	41	Analogue SPK Output Control 0	0	0	0	0	0	0	0	0	0	0	0	0	0	0	0	0	0000_0000_0000_0000
67	43	Dc Servo 0	0	0	0	0	0	0	0	0	0	0	0	0	0	0	0	0	0000_0000_0001_0000
69	45	Dc Servo 2	0	0	0	0	0	0	0	0	0	0	0	0	0	0	0	0	0000_0000_1010_0100
71	47	Dc Servo 4	0	0	0	0	0	0	0	0	0	0	0	0	0	0	0	0	0000_0000_0000_0000
72	48	Dc Servo 5	0	0	0	0	0	0	0	0	0	0	0	0	0	0	0	0	0000_0000_0000_0000
73	49	Dc Servo 6	0	0	0	0	0	0	0	0	0	0	0	0	0	0	0	0	0000_0000_0000_0000
74	4A	Dc Servo 7	0	0	0	0	0	0	0	0	0	0	0	0	0	0	0	0	0000_0000_0000_0000
81	51	DC Servo Feedback 1	0	0	0	0	0	0	0	0	0	0	0	0	0	0	0	0	0000_0000_0000_0000
82	52	DC Servo Feedback 2	0	0	0	0	0	0	0	0	0	0	0	0	0	0	0	0	0000_0000_0000_0000
83	53	DC Servo Feedback 3	0	0	0	0	0	0	0	0	0	0	0	0	0	0	0	0	0000_0000_0000_0000
84	54	DC Servo Feedback 4	0	0	0	0	0	0	0	0	0	0	0	0	0	0	0	0	0000_0000_0000_0000

Dec. Addr	Hex Addr	Name	15	14	13	12	11	10	9	8	7	6	5	4	3	2	1	0	Bin Default
90	5A	Analogue IFO	0	0	0	0	0	0	0	0	HPL_RMW_SHO_RT	HPL_ENA_OUTP	HPL_ENA_DLY	HPL_ENA	HPL_RMW_SHO_RT	HPL_ENA_OUTP	HPL_ENA_DLY	HPL_ENA	0000_0000_0000_0000
94	5E	Analogue Lineout 0	0	0	0	0	0	0	0	0	LINEOUTL_RMW_SHORT	LINEOUTL_ENA_OUTP	LINEOUTL_ENA_DLY	LINEOUTL_ENA	LINEOUTL_RMW_SHORT	LINEOUTL_ENA_OUTP	LINEOUTL_ENA_DLY	LINEOUTL_ENA	0000_0000_0000_0000
98	62	Charge Pump 0	0	0	0	0	0	0	0	0	0	0	0	0	0	0	0	0	0000_0000_0000_0000
104	68	Class W 0	0	0	0	0	0	0	0	0	0	0	0	1	0	0	0	0	0000_0000_0000_0000
108	6C	Write Sequencer 0	0	0	0	0	0	0	0	0	WSEQ_CLK_ENA	0	0	0	0	0	0	0	0000_0000_0000_0000
109	6D	Write Sequencer 1	0	0	0	0	0	0	0	0	0	0	0	0	0	0	0	0	0000_0000_0000_0000
110	6E	Write Sequencer 2	0	0	0	0	0	0	0	0	0	0	0	0	0	0	0	0	0000_0000_0000_0000
111	6F	Write Sequencer 3	0	0	0	0	0	0	0	0	0	0	0	0	0	0	0	0	0000_0000_0000_0000
112	70	Write Sequencer 4	0	0	0	0	0	0	0	0	0	0	0	0	0	0	0	0	0000_0000_0000_0000
116	74	GPIO Control 1	0	0	0	0	0	0	0	0	0	0	0	0	0	0	0	0	0000_0000_1010_1000
117	75	GPIO Control 2	0	0	0	0	0	0	0	0	0	0	0	0	0	0	0	0	0000_0000_1010_1000
118	76	GPIO Control 3	0	0	0	0	0	0	0	0	0	0	0	0	0	0	0	0	0000_0000_1010_1000
119	77	GPIO Control 4	0	0	0	0	0	0	0	0	0	0	0	0	0	0	0	0	0000_0000_1010_1000
120	78	GPIO Control 5	0	0	0	0	0	0	0	0	0	0	0	0	0	0	0	0	0000_0000_1010_1000
121	79	Interrupt Status 1	MCSHRT_ENT	MCDET_ENT	WSEQ_BUSY_EN	0	0	0	0	0	0	0	0	0	0	0	0	0	0000_0000_0000_0000
122	7A	Interrupt Status 1 Mask	IM_MCSHRT_ENT	IM_MCDET_ENT	IM_WSEQ_BUSY_ENT	1	1	1	1	1	1	1	1	1	1	1	1	1	1111_1111_1111_1111
123	7B	Interrupt Polarity 1	MCSHRT_INV	MCDET_INV	0	0	0	0	0	0	0	0	0	0	0	0	0	0	0000_0000_0000_0000
126	7E	Interrupt Control	0	0	0	0	0	0	0	0	0	0	0	0	0	0	0	0	0000_0000_0000_0000
128	80	PLL Control 1	0	0	0	0	0	0	0	0	0	0	0	0	0	0	0	0	0000_0000_0000_0000
129	81	PLL Control 2	0	0	0	0	0	0	0	0	0	0	0	0	0	0	0	0	0000_0000_0000_0000
130	82	PLL Control 3	0	0	0	0	0	0	0	0	0	0	0	0	0	0	0	0	0000_0000_0000_0000
131	83	PLL Control 4	0	0	0	0	0	0	0	0	0	0	0	0	0	0	0	0	0000_0000_0000_0000
164	A4	Clock Rate Test 4	0	0	1	0	0	0	0	0	0	0	0	1	1	0	0	0	0000_1000_0011_1000
172	AC	Analogue Output Bias 0	0	0	0	0	0	0	0	0	0	0	0	0	0	0	0	0	0000_0000_0000_0000
187	BB	Analogue Output Bias 2	0	0	0	0	0	0	0	0	0	0	0	0	0	0	0	0	0000_0000_0000_0000

**REGISTER BITS BY ADDRESS**

REGISTER ADDRESS	BIT	LABEL	DEFAULT	DESCRIPTION
R0 (00h) SW Reset and ID	15:0	SW_RST_DEV_ID1 [15:0]	1000_1001_0000_0011	Writing to this register resets all registers to their default state. Reading from this register will indicate Device ID 8903h.

**Register 00h** SW Reset and ID

REGISTER ADDRESS	BIT	LABEL	DEFAULT	DESCRIPTION
R1 (01h) Revision Number	3:0	CHIP_REV [3:0]	0010	Reading from this register will indicate the Revision ID.

**Register 01h** Revision Number

REGISTER ADDRESS	BIT	LABEL	DEFAULT	DESCRIPTION
R4 (04h) Bias Control 0	4	POBCTRL	1	Selects the bias current source for output amplifiers and VMID buffer 0 = Default bias 1 = Start-Up bias
	3:2	ISEL [1:0]	10	Master Bias control 00 = Normal bias x 0.5 01 = Normal bias x 0.75 10 = Normal bias 11 = Normal bias x 1.5
	1	STARTUP_BIAS_EN A	0	Enables the Start-Up bias current generator 0 = Disabled 1 = Enabled
	0	BIAS_ENA	0	Enables the Normal bias current generator (for all analogue functions) 0 = Disabled 1 = Enabled

**Register 04h** Bias Control 0

REGISTER ADDRESS	BIT	LABEL	DEFAULT	DESCRIPTION
R5 (05h) VMID Control 0	7	VMID_TIE_ENA	0	VMID buffer to Differential Lineouts 0 = Disabled 1 = Enabled (only applies when relevant outputs are disabled, ie. SPLK=0 or SPKR=0. Resistance is controlled by VROI.)
	6	BUFIO_ENA	0	VMID buffer to unused input and output pins. 0 = Disabled 1 = Enabled
	5	VMID_IO_ENA	0	Enables the Start-Up bias current generator 0 = Disabled 1 = Enabled (same functionality as STARTUP_BIAS_ENA)
	4:3	VMID_SOFT [1:0]	00	VMID soft start enable / slew rate control 00 = Disabled 01 = Fast soft start 10 = Nominal soft start 11 = Slow soft start
	2:1	VMID_RES [1:0]	00	VMID Divider Enable and Select 00 = VMID disabled (for OFF mode) 01 = 2 x 50k divider (for normal operation) 10 = 2 x 250k divider (for low power standby) 11 = 2 x 5k divider (for fast start-up)
	0	VMID_BUF_ENA	0	VMID Buffer Enable 0 = Disabled 1 = Enabled

Register 05h VMID Control 0

REGISTER ADDRESS	BIT	LABEL	DEFAULT	DESCRIPTION
R6 (06h) Mic Bias Control 0	5:4	MICDET_THR [1:0]	00	MICBIAS Current Detect Insertion Threshold 00 = 0.063mA 01 = 0.26mA 10 = 0.45mA 11 = 0.635mA Values are scaled with AVDD. Figures shown are based on AVDD=1.8V.
	3:2	MICSHORT_THR [1:0]	00	MICBIAS Short Circuit Button Push Threshold 00 = 0.52mA 01 = 0.77mA 10 = 1.2mA 11 = 1.43mA Values are scaled with AVDD. Figures shown are based on AVDD=1.8V.
	1	MICDET_ENA	0	MICBIAS Current and Short Circuit Detect Enable 0 = disabled 1 = enabled
	0	MICBIAS_ENA	0	MICBIAS Enable 0 = disabled 1 = enabled

Register 06h Mic Bias Control 0

REGISTER ADDRESS	BIT	LABEL	DEFAULT	DESCRIPTION
R8 (08h) Analogue DAC 0	5	DAC_BIAS_BOOST	0	DAC Bias boost 0 = Disable 1 = Enable When DAC Bias boost is enabled, the bias selected by DACBIAS_SEL and DACVMID_BIAS_SEL are both doubled.
	4:3	DACBIAS_SEL [1:0]	00	DAC bias current select 00 = Normal bias 01 = Normal bias x 0.5 10 = Normal bias x 0.66 11 = Normal bias x 0.75
	2:1	DACVMID_BIAS_SEL [1:0]	00	DAC VMID buffer bias select 00 = Normal bias 01 = Normal bias x 0.5 10 = Normal bias x 0.66 11 = Normal bias x 0.75

Register 08h Analogue DAC 0

REGISTER ADDRESS	BIT	LABEL	DEFAULT	DESCRIPTION
R10 (0Ah) Analogue ADC 0	0	ADC_OSR128	1	ADC Oversampling Ratio 0 = Low Power (64 x fs) 1 = High Performance (128 x fs) Note that the Low Power options is not supported when CLK_SYS_MODE=10

Register 10h Analogue ADC 0

REGISTER ADDRESS	BIT	LABEL	DEFAULT	DESCRIPTION
R12 (0Ch) Power Management 0	1	INL_ENA	0	Left Input PGA Enable 0 = disabled 1 = enabled
	0	INR_ENA	0	Right Input PGA Enable 0 = disabled 1 = enabled

Register 0Ch Power Management 0

REGISTER ADDRESS	BIT	LABEL	DEFAULT	DESCRIPTION
R13 (0Dh) Power Management 1	1	MIXOUTL_ENA	0	Left Output Mixer Enable 0 = disabled 1 = enabled
	0	MIXOUTR_ENA	0	Right Output Mixer Enable 0 = disabled 1 = enabled

Register 0Dh Power Management 1

REGISTER ADDRESS	BIT	LABEL	DEFAULT	DESCRIPTION
R14 (0Eh) Power Management 2	1	HPL_PGA_ENA	0	Left Headphone Output Enable 0 = disabled 1 = enabled
	0	HPR_PGA_ENA	0	Right Headphone Output Enable 0 = disabled 1 = enabled

Register 0Eh Power Management 2

REGISTER ADDRESS	BIT	LABEL	DEFAULT	DESCRIPTION
R15 (0Fh) Power Management 3	1	LINEOUTL_PGA_ENA	0	Left Line Output Enable 0 = disabled 1 = enabled
	0	LINEOUTR_PGA_ENA	0	Right Line Output Enable 0 = disabled 1 = enabled

Register 0Fh Power Management 3

REGISTER ADDRESS	BIT	LABEL	DEFAULT	DESCRIPTION
R16 (10h) Power Management 4	1	MIXSPKL_ENA	0	Left Speaker Mixer Enable 0 = disabled 1 = enabled
	0	MIXSPKR_ENA	0	Right Speaker Mixer Enable 0 = disabled 1 = enabled

Register 10h Power Management 4

REGISTER ADDRESS	BIT	LABEL	DEFAULT	DESCRIPTION
R17 (11h) Power Management 5	1	SPKL_ENA	0	Left Speaker Output Enable 0 = disabled 1 = enabled
	0	SPKR_ENA	0	Right Speaker Output Enable 0 = disabled 1 = enabled

Register 11h Power Management 5



REGISTER ADDRESS	BIT	LABEL	DEFAULT	DESCRIPTION
R18 (12h) Power Management 6	3	DACL_ENA	0	Left DAC Enable 0 = DAC disabled 1 = DAC enabled
	2	DACR_ENA	0	Right DAC Enable 0 = DAC disabled 1 = DAC enabled
	1	ADCL_ENA	0	Left ADC Enable 0 = disabled 1 = enabled
	0	ADCR_ENA	0	Right ADC Enable 0 = disabled 1 = enabled

Register 12h Power Management 6

REGISTER ADDRESS	BIT	LABEL	DEFAULT	DESCRIPTION
R20 (14h) Clock Rates 0	0	MCLKDIV2	0	Enables divide by 2 on MCLK 0 = CLK_SYS = MCLK 1 = CLK_SYS = MCLK / 2

Register 14h Clock Rates 0

REGISTER ADDRESS	BIT	LABEL	DEFAULT	DESCRIPTION
R21 (15h) Clock Rates 1	15	CLK_SRC_SEL	0	SYSCCLK Source Select 0 = MCLK 1 = FLL output
	13:10	CLK_SYS_RATE [3:0]	0011	CLK_SYS / Sample rate (fs) ratio  if CLK_SYS_MODE = 00 (256*fs related clocks) 0000 = 64*fs 0001 = 128*fs 0010 = 192*fs 0011 = 256*fs 0100 = 384*fs 0101 = 512*fs 0110 = 768*fs 0111 = 1024 *fs 1000 = 1408*fs 1001 = 1536*fs 1010 to 1111 = Reserved  if CLK_SYS_MODE = 01 (272*fs related clocks) 0000 = 68*fs 0001 = 136*fs 0010 = 204*fs 0011 = 272*fs 0100 = 408*fs 0101 = 544*fs 0110 = 816*fs

REGISTER ADDRESS	BIT	LABEL	DEFAULT	DESCRIPTION
				0111 = 1088 *fs 1000 = 1496*fs 1001 = 1632*fs 1010 to 1111 = Reserved  if CLK_SYS_MODE = 10 (250*fs related clocks) 0000 = 125*fs 0001 = 125*fs 0010 = 250*fs 0011 = 250*fs 0100 = 375*fs 0101 = 500*fs 0110 = 750*fs 0111 = 1000 *fs 1000 = 1000*fs 1001 = 1500*fs 1010 to 1111 = Reserved
	9:8	CLK_SYS_MODE [1:0]	00	CLK_SYS mode  00 = 256*fs related 01 = 272*fs related 10 = 250*fs related 11 = Reserved
	3:0	SAMPLE_RATE [3:0]	1000	Selects the Sample Rate (fs) 0000 = 8kHz 0001 = 11.025kHz 0010 = 12kHz 0011 = 16kHz 0100 = 22.05kHz 0101 = 24kHz 0110 = 32kHz 0111 = 44.1kHz 1000 = 48kHz 1001 = 88.2kHz (Not available for Digital Microphone. Not used for 88.2kHz ADC.) 1010 = 96kHz (Not available for Digital Microphone. Not used for 96kHz ADC). 1011 to 1111 = Reserved  If the desired sample rate is not listed in this table, then the closest alternative should be chosen.

Register 15h Clock Rates 1

REGISTER ADDRESS	BIT	LABEL	DEFAULT	DESCRIPTION
R22 (16h) Clock Rates 2	2	CLK_SYS_ENA	0	System Clock enable 0 = Disabled 1 = Enabled
	1	CLK_DSP_ENA	0	DSP Clock enable 0 = Disabled 1 = Enabled
	0	TO_ENA	0	Zero Cross timeout enable 0 = Disabled 1 = Enabled

Register 16h Clock Rates 2

REGISTER ADDRESS	BIT	LABEL	DEFAULT	DESCRIPTION
R24 (18h) Audio Interface 0	12	DACL_DATINV	0	Left DAC Invert 0 = Left DAC output not inverted 1 = Left DAC output inverted
	11	DACR_DATINV	0	Right DAC Invert 0 = Right DAC output not inverted 1 = Right DAC output inverted
	10:9	DAC_BOOST [1:0]	00	DAC Digital Input Volume Boost 00 = 0dB 01 = +6dB (Input data must not exceed -6dBFS) 10 = +12dB (Input data must not exceed -12dBFS) 11 = +18dB (Input data must not exceed -18dBFS)
	8	LOOPBACK	0	Digital Loopback Function 0 = No loopback 1 = Loopback enabled (ADC data output is directly input to DAC data input)
	7	AIFADCL_SRC	0	Left Digital Audio channel source 0 = Left ADC data is output on left channel 1 = Right ADC data is output on left channel
	6	AIFADCR_SRC	1	Right Digital Audio channel source 0 = Left ADC data is output on right channel 1 = Right ADC data is output on right channel
	5	AIFDACL_SRC	0	Left DAC Data Source Select 0 = Left DAC outputs left channel data 1 = Left DAC outputs right channel data
	4	AIFDACR_SRC	1	Right DAC Data Source Select 0 = Right DAC outputs left channel data 1 = Right DAC outputs right channel data
	3	ADC_COMP	0	ADC Companding Enable 0 = disabled 1 = enabled
	2	ADC_COMPMODE	0	ADC Companding Type 0 = $\mu$ -law 1 = A-law
	1	DAC_COMP	0	DAC Companding Enable 0 = disabled 1 = enabled
	0	DAC_COMPMODE	0	DAC Companding Type 0 = $\mu$ -law 1 = A-law

Register 18h Audio Interface 0

REGISTER ADDRESS	BIT	LABEL	DEFAULT	DESCRIPTION
R25 (19h) Audio Interface 1	13	AIFDAC_TDM	0	DAC TDM Enable 0 = Normal DACDAT operation 1 = TDM enabled on DACDAT
	12	AIFDAC_TDM_CHAN	0	DACDAT TDM Channel Select 0 = DACDAT data input on slot 0 1 = DACDAT data input on slot 1
	11	AIFADC_TDM	0	ADC TDM Enable 0 = Normal ADCDAT operation 1 = TDM enabled on ADCDAT
	10	AIFADC_TDM_CHAN	0	ADCDAT TDM Channel Select 0 = ADCDAT outputs data on slot 0 1 = ADCDAT output data on slot 1
	9	LRCLK_DIR	0	Audio Interface LRC Direction 0 = LRC is input 1 = LRC is output
	7	AIF_BCLK_INV	0	BCLK Invert 0 = BCLK not inverted 1 = BCLK inverted
	6	BCLK_DIR	0	Audio Interface BCLK Direction 0 = BCLK is input 1 = BCLK is output
	4	AIF_LRCLK_INV	0	LRC Polarity / DSP Mode A-B select.  Right, left and I2S modes – LRC polarity 0 = Not Inverted 1 = Inverted  DSP Mode – Mode A-B select 0 = MSB is available on 2nd BCLK rising edge after LRC rising edge (mode A) 1 = MSB is available on 1st BCLK rising edge after LRC rising edge (mode B)
	3:2	AIF_WL [1:0]	00	Digital Audio Interface Word Length 00 = 16 bits 01 = 20 bits 10 = 24 bits 11 = 32 bits
1:0	AIF_FMT [1:0]	10	Digital Audio Interface Format 00 = Right Justified 01 = Left Justified 10 = I2S 11 = DSP	

Register 19h Audio Interface 1

REGISTER ADDRESS	BIT	LABEL	DEFAULT	DESCRIPTION
R26 (1Ah) Audio Interface 2	4:0	BCLK_DIV [4:0]	0_1000	BCLK Frequency (Master Mode) 00000 = CLK_SYS 00001 = Reserved 00010 = CLK_SYS / 2 00011 = CLK_SYS / 3 00100 = CLK_SYS / 4 00101 = CLK_SYS / 5 00110 = Reserved 00111 = CLK_SYS / 6 01000 = CLK_SYS / 8 (default) 01001 = CLK_SYS / 10 01010 = Reserved 01011 = CLK_SYS / 12 01100 = CLK_SYS / 16 01101 = CLK_SYS / 20 01110 = CLK_SYS / 22 01111 = CLK_SYS / 24 10000 = Reserved 10001 = CLK_SYS / 30 10010 = CLK_SYS / 32 10011 = CLK_SYS / 44 10100 = CLK_SYS / 48

Register 1Ah Audio Interface 2

REGISTER ADDRESS	BIT	LABEL	DEFAULT	DESCRIPTION
R27 (1Bh) Audio Interface 3	10:0	LRCLK_RATE [10:0]	000_0010_0010	LRC Rate (Master Mode) LRC clock output = BCLK / LRCLK_RATE Integer (LSB = 1) Valid range: 8 to 2047 50:50 LRCLK duty cycle is only guaranteed with even values (8, 10, ... 2046).

Register 1Bh Audio Interface 3

REGISTER ADDRESS	BIT	LABEL	DEFAULT	DESCRIPTION
R30 (1Eh) DAC Digital Volume Left	8	DACVU	0	DAC Volume Update Writing a 1 to this bit causes left and right DAC volume to be updated simultaneously
	7:0	DACL_VOL [7:0]	1100_0000	Left DAC Digital Volume 00h = Mute 01h = -71.625dB 02h = -71.250dB ... (0.375dB steps) C0h to FFh = 0dB

Register 1Eh DAC Digital Volume Left

REGISTER ADDRESS	BIT	LABEL	DEFAULT	DESCRIPTION
R31 (1Fh) DAC Digital Volume Right	8	DACVU	0	DAC Volume Update Writing a 1 to this bit causes left and right DAC volume to be updated simultaneously
	7:0	DACR_VOL [7:0]	1100_0000	Right DAC Digital Volume 00h = Mute 01h = -71.625dB 02h = -71.250dB ... (0.375dB steps) C0h to FFh = 0dB

Register 1Fh DAC Digital Volume Right

REGISTER ADDRESS	BIT	LABEL	DEFAULT	DESCRIPTION
R32 (20h) DAC Digital 0	11:8	ADCL_DAC_SVOL [3:0]	0000	Left Digital Sidetone Volume 0000 = -36dB 0001 = -33dB (... 3dB steps) 1011 = -3dB 11XX = 0dB
	7:4	ADCR_DAC_SVOL [3:0]	0000	Right Digital Sidetone Volume 0000 = -36dB 0001 = -33dB (... 3dB steps) 1011 = -3dB 11XX = 0dB
	3:2	ADC_TO_DACL [1:0]	00	Left DAC Digital Sidetone Source 00 = No sidetone 01 = Left ADC 10 = Right ADC 11 = Reserved
	1:0	ADC_TO_DACR [1:0]	00	Right DAC Digital Sidetone Source 00 = No sidetone 01 = Left ADC 10 = Right ADC 11 = Reserved

Register 20h DAC Digital 0

REGISTER ADDRESS	BIT	LABEL	DEFAULT	DESCRIPTION
R33 (21h) DAC Digital 1	12	DAC_MONO	0	DAC Mono Mix 0 = Stereo 1 = Mono (Mono mix output on enabled DAC)
	11	DAC_SB_FILT	0	Selects DAC filter characteristics 0 = Normal mode 1 = Sloping stopband mode (recommended when fs <= 24kHz)
	10	DAC_MUTERATE	0	DAC Soft Mute Ramp Rate 0 = Fast ramp (fs/2, maximum ramp time is 10.7ms at fs=48k) 1 = Slow ramp (fs/32, maximum ramp time is 171ms at fs=48k)
	9	DAC_MUTEMODE	0	DAC Soft Mute Mode 0 = Disabling soft-mute (DAC_MUTE=0) will cause the DAC volume to change immediately to DACL_VOL and DACR_VOL settings 1 = Disabling soft-mute (DAC_MUTE=0) will cause the DAC volume to ramp up gradually to the DACL_VOL and DACR_VOL settings
	3	DAC_MUTE	0	DAC Soft Mute Control 0 = DAC Un-mute 1 = DAC Mute
	2:1	DEEMPH [1:0]	00	DAC De-Emphasis Control 00 = No de-emphasis 01 = 32kHz sample rate 10 = 44.1kHz sample rate 11 = 48kHz sample rate
	0	DAC_OSR	0	DAC Oversampling Control 0 = Low power (normal oversample) 1 = High performance (double rate)

Register 21h DAC Digital 1

REGISTER ADDRESS	BIT	LABEL	DEFAULT	DESCRIPTION
R36 (24h) ADC Digital Volume Left	8	ADCVU	0	ADC Volume Update Writing a 1 to this bit causes left and right ADC volume to be updated simultaneously
	7:0	ADCL_VOL [7:0]	1100_0000	Left ADC Digital Volume 00h = Mute 01h = -71.625dB 02h = -71.250dB ... (0.375dB steps) C0h = 0dB ... (0.375dB steps) EFh = +17.625dB F0h to FFh = +17.625dB

Register 24h ADC Digital Volume Left

REGISTER ADDRESS	BIT	LABEL	DEFAULT	DESCRIPTION
R37 (25h) ADC Digital Volume Right	8	ADCVU	0	ADC Volume Update Writing a 1 to this bit causes left and right ADC volume to be updated simultaneously
	7:0	ADCR_VOL [7:0]	1100_0000	Right ADC Digital Volume 00h = Mute 01h = -71.625dB 02h = -71.250dB ... (0.375dB steps) C0h = 0dB ... (0.375dB steps) EFh = +17.625dB F0h to FFh = +17.625dB

Register 25h ADC Digital Volume Right

REGISTER ADDRESS	BIT	LABEL	DEFAULT	DESCRIPTION
R38 (26h) ADC Digital 0	6:5	ADC_HPF_CUT [1:0]	00	ADC Digital High Pass Filter Cut-Off Frequency (fc) 00 = Hi-fi mode (fc=4Hz at fs=48kHz) 01 = Voice mode 1 (fc=127Hz at fs=16kHz) 10 = Voice mode 2 (fc=130Hz at fs=8kHz) 11 = Voice mode 3 (fc=267Hz at fs=8kHz) (Note: fc scales with sample rate fs.)
	4	ADC_HPF_ENA	0	ADC Digital High Pass Filter Enable 0 = disabled 1 = enabled
	1	ADCL_DATINV	0	Left ADC Invert 0 = Left ADC output not inverted 1 = Left ADC output inverted
	0	ADCR_DATINV	0	Right ADC Invert 0 = Right ADC output not inverted 1 = Right ADC output inverted

Register 26h ADC Digital 0



REGISTER ADDRESS	BIT	LABEL	DEFAULT	DESCRIPTION
R40 (28h) DRC 0	15	DRC_ENA	0	DRC enable 1 = enabled 0 = disabled
	12:11	DRC_THRESH_HYST [1:0]	01	Gain smoothing hysteresis threshold 00 = Low 01 = Medium (recommended) 10 = High 11 = Reserved
	10:6	DRC_STARTUP_GAIN [4:0]	0_0110	Initial gain at DRC startup 00000 = -18dB 00001 = -15dB 00010 = -12dB 00011 = -9dB 00100 = -6dB 00101 = -3dB 00110 = 0dB (default) 00111 = 3dB 01000 = 6dB 01001 = 9dB 01010 = 12dB 01011 = 15dB 01100 = 18dB 01101 = 21dB 01110 = 24dB 01111 = 27dB 10000 = 30dB 10001 = 33dB 10010 = 36dB 10011 to 11111 = Reserved
	5	DRC_FF_DELAY	1	Feed-forward delay for anti-clip feature 0 = 5 samples 1 = 9 samples Time delay can be calculated as $5/fs$ or $9/fs$ , where $fs$ is the sample rate.
	3	DRC_SMOOTH_ENA	1	Gain smoothing enable 0 = disabled 1 = enabled
	2	DRC_QR_ENA	1	Quick release enable 0 = disabled 1 = enabled
	1	DRC_ANTICLIP_ENA	1	Anti-clip enable 0 = disabled 1 = enabled
0	DRC_HYST_ENA	1	Gain smoothing hysteresis enable 0 = disabled 1 = enabled	

Register 28h DRC 0

REGISTER ADDRESS	BIT	LABEL	DEFAULT	DESCRIPTION
R41 (29h) DRC 1	15:12	DRC_ATTACK_RATE [3:0]	0011	Gain attack rate (seconds/6dB) 0000 = Reserved 0001 = 182µs 0010 = 363µs 0011 = 726µs (default) 0100 = 1.45ms 0101 = 2.9ms 0110 = 5.8ms 0111 = 11.6ms 1000 = 23.2ms 1001 = 46.4ms 1010 = 92.8ms 1011-1111 = Reserved
	11:8	DRC_DECAY_RATE [3:0]	0010	Gain decay rate (seconds/6dB) 0000 = 186ms 0001 = 372ms 0010 = 743ms (default) 0011 = 1.49s 0100 = 2.97s 0101 = 5.94s 0110 = 11.89s 0111 = 23.78s 1000 = 47.56s 1001-1111 = Reserved
	7:6	DRC_THRESH_QR [1:0]	01	Quick release crest factor threshold 00 = 12dB 01 = 18dB (default) 10 = 24dB 11 = 30dB
	5:4	DRC_RATE_QR [1:0]	00	Quick release decay rate (seconds/6dB) 00 = 0.725ms (default) 01 = 1.45ms 10 = 5.8ms 11 = Reserved
	3:2	DRC_MINGAIN [1:0]	00	Minimum gain the DRC can use to attenuate audio signals 00 = 0dB (default) 01 = -6dB 10 = -12dB 11 = -18dB
	1:0	DRC_MAXGAIN [1:0]	01	Maximum gain the DRC can use to boost audio signals 00 = 12dB 01 = 18dB (default) 10 = 24dB 11 = 36dB

Register 29h DRC 1

REGISTER ADDRESS	BIT	LABEL	DEFAULT	DESCRIPTION
R42 (2Ah) DRC 2	5:3	DRC_R0_SLOPE_COMP [2:0]	100	Compressor slope R0 000 = 1 (no compression) 001 = 1/2 010 = 1/4 011 = 1/8 100 = 1/16 101 = 0 110 = Reserved 111 = Reserved
	2:0	DRC_R1_SLOPE_COMP [2:0]	000	Compressor slope R1 000 = 1 (no compression) 001 = 1/2 010 = 1/4 011 = 1/8 100 = 0 101 = Reserved 11X = Reserved

Register 2Ah DRC 2

REGISTER ADDRESS	BIT	LABEL	DEFAULT	DESCRIPTION
R43 (2Bh) DRC 3	10:5	DRC_THRESH_COMP [5:0]	00_0000	Compressor threshold T (dB) 000000 = 0dB 000001 = -0.75dB 000010 = -1.5dB ... (-0.75dB steps) 111100 = -45dB 111101 = Reserved 11111X = Reserved
	4:0	DRC_AMP_COMP [4:0]	0_0000	Compressor amplitude at threshold YT (dB) 00000 = 0dB 00001 = -0.75dB 00010 = -1.5dB ... (-0.75dB steps) 11110 = -22.5dB 11111 = Reserved

Register 2Bh DRC 3

REGISTER ADDRESS	BIT	LABEL	DEFAULT	DESCRIPTION
R44 (2Ch) Analogue Left Input 0	7	LINMUTE	1	Left Input PGA Mute 0 = not muted 1 = muted
	4:0	LIN_VOL [4:0]	0_0101	Left Input PGA Volume  If L_MODE = 00 (Single ended) OR L_MODE = 01 (Differential Line) 00000 -1.5 00001 -1.3 00010 -1.0 00011 -0.7 00100 -0.3 00101 +0.0 (default) 00110 +0.3 00111 +0.7 01000 +1.0 01001 +1.4 01010 +1.8 01011 +2.3 01100 +2.7 01101 +3.2 01110 +3.7 01111 +4.2 10000 +4.8 10001 +5.4 10010 +6.0 10011 +6.7 10100 +7.5 10101 +8.3 10110 +9.2 10111 +10.2 11000 +11.4 11001 +12.7 11010 +14.3 11011 +16.2 11100 +19.2 11101 +22.3 11110 +25.2 11111 +28.3  If L_MODE = 1X (Differential MIC) 00000 Not valid 00001 +12 00010 +15 00011 +18 00100 +21 00101 (default) +24 00110 +27 00111 +30 01XXX +30 1XXXX +30

Register 2Ch Analogue Left Input 0

REGISTER ADDRESS	BIT	LABEL	DEFAULT	DESCRIPTION
R45 (2Dh) Analogue Right Input 0	7	RINMUTE	1	Right Input PGA Mute 0 = not muted 1 = muted
	4:0	RIN_VOL [4:0]	0_0101	Right Input PGA Volume  If R_MODE = 00 (Single ended) OR R_MODE = 01 (Differential Line) 00000 -1.5 00001 -1.3 00010 -1.0 00011 -0.7 00100 -0.3 00101 +0.0 (default) 00110 +0.3 00111 +0.7 01000 +1.0 01001 +1.4 01010 +1.8 01011 +2.3 01100 +2.7 01101 +3.2 01110 +3.7 01111 +4.2 10000 +4.8 10001 +5.4 10010 +6.0 10011 +6.7 10100 +7.5 10101 +8.3 10110 +9.2 10111 +10.2 11000 +11.4 11001 +12.7 11010 +14.3 11011 +16.2 11100 +19.2 11101 +22.3 11110 +25.2 11111 +28.3  If R_MODE = 1X (Differential MIC) 00000 Not valid 00001 +12 00010 +15 00011 +18 00100 +21 00101 (default) +24 00110 +27 00111 +30 01XXX +30 1XXXX +30

Register 2Dh Analogue Right Input 0

REGISTER ADDRESS	BIT	LABEL	DEFAULT	DESCRIPTION
R46 (2Eh) Analogue Left Input 1	6	INL_CM_ENA	1	Left Input PGA Common Mode Rejection enable 0 = Disabled 1 = Enabled (only available for L_MODE=01 – Differential Line)
	5:4	L_IP_SEL_N [1:0]	00	In Single-Ended or Differential Line Modes, this field selects the input pin for the inverting side of the left input path. In Differential Mic Mode, this field selects the input pin for the non-inverting side of the left input path. 00 = IN1L 01 = IN2L 1X = IN3L
	3:2	L_IP_SEL_P [1:0]	01	In Single-Ended or Differential Line Modes, this field selects the input pin for the non-inverting side of the left input path. In Differential Mic Mode, this field selects the input pin for the inverting side of the left input path. 00 = IN1L 01 = IN2L 1X = IN3L
	1:0	L_MODE [1:0]	00	Sets the mode for the left analogue input: 00 = Single-Ended 01 = Differential Line 10 = Differential MIC 11 = Reserved

Register 2Eh Analogue Left Input 1

REGISTER ADDRESS	BIT	LABEL	DEFAULT	DESCRIPTION
R47 (2Fh) Analogue Right Input 1	6	INR_CM_ENA	1	Right Input PGA Common Mode Rejection enable 0 = Disabled 1 = Enabled (only available for R_MODE=01 – Differential Line)
	5:4	R_IP_SEL_N [1:0]	00	In Single-Ended or Differential Line Modes, this field selects the input pin for the inverting side of the right input path. In Differential Mic Mode, this field selects the input pin for the non-inverting side of the right input path. 00 = IN1R 01 = IN2R 1X = IN3R
	3:2	R_IP_SEL_P [1:0]	01	In Single-Ended or Differential Line Modes, this field selects the input pin for the non-inverting side of the right input path. In Differential Mic Mode, this field selects the input pin for the inverting side of the right input path. 00 = IN1R 01 = IN2R 1X = IN3R

REGISTER ADDRESS	BIT	LABEL	DEFAULT	DESCRIPTION
	1:0	R_MODE [1:0]	00	Sets the mode for the right analogue input: 00 = Single-Ended 01 = Differential Line 10 = Differential MIC 11 = Reserved

**Register 2Fh** Analogue Right Input 1

REGISTER ADDRESS	BIT	LABEL	DEFAULT	DESCRIPTION
R50 (32h) Analogue Left Mix 0	3	DACL_TO_MIXOUTL	1	Left DAC to Left Output Mixer Enable 0 = disabled 1 = enabled
	2	DACR_TO_MIXOUTL	0	Right DAC to Left Output Mixer Enable 0 = disabled 1 = enabled
	1	BYPASSL_TO_MIXOUTL	0	Left Analogue Input to Left Output Mixer Enable 0 = disabled 1 = enabled
	0	BYPASSR_TO_MIXOUTL	0	Right Analogue Input to Left Output Mixer Enable 0 = disabled 1 = enabled

**Register 32h** Analogue Left Mix 0

REGISTER ADDRESS	BIT	LABEL	DEFAULT	DESCRIPTION
R51 (33h) Analogue Right Mix 0	3	DACL_TO_MIXOUTR	0	Left DAC to Right Output Mixer Enable 0 = disabled 1 = enabled
	2	DACR_TO_MIXOUTR	1	Right DAC to Right Output Mixer Enable 0 = disabled 1 = enabled
	1	BYPASSL_TO_MIXOUTR	0	Left Analogue Input to Right Output Mixer Enable 0 = disabled 1 = enabled
	0	BYPASSR_TO_MIXOUTR	0	Right Analogue Input to Right Output Mixer Enable 0 = disabled 1 = enabled

**Register 33h** Analogue Right Mix 0

REGISTER ADDRESS	BIT	LABEL	DEFAULT	DESCRIPTION
R52 (34h) Analogue Spk Mix Left 0	3	DACL_TO_MIXSPKL	0	Left DAC to Left Spkr Mixer Enable 0 = disabled 1 = enabled
	2	DACR_TO_MIXSPKL	0	Right DAC to Left Spkr Mixer Enable 0 = disabled 1 = enabled
	1	BYPASSL_TO_MIXSPKL	0	Left Analogue Input to Left Spkr Mixer Enable 0 = disabled 1 = enabled
	0	BYPASSR_TO_MIXSPKL	0	Right Analogue Input to Left Spkr Mixer Enable 0 = disabled 1 = enabled

Register 34h Analogue Spk Mix Left 0

REGISTER ADDRESS	BIT	LABEL	DEFAULT	DESCRIPTION
R53 (35h) Analogue Spk Mix Left 1	3	DACL_MIXSPKL_VOL	0	Left DAC to Left Spkr Mixer volume control 0 = 0dB 1 = -6dB
	2	DACR_MIXSPKL_VOL	0	Right DAC to Left Spkr Mixer volume control 0 = 0dB 1 = -6dB
	1	BYPASSL_MIXSPKL_VOL	0	Left Analogue Input to Left Spkr Mixer volume control 0 = 0dB 1 = -6dB
	0	BYPASSR_MIXSPKL_VOL	0	Right Analogue Input to Left Spkr Mixer volume control 0 = 0dB 1 = -6dB

Register 35h Analogue Spk Mix Left 1

REGISTER ADDRESS	BIT	LABEL	DEFAULT	DESCRIPTION
R54 (36h) Analogue Spk Mix Right 0	3	DACL_TO_MIXSPKR	0	Left DAC to Right Spkr Mixer Enable 0 = disabled 1 = enabled
	2	DACR_TO_MIXSPKR	0	Right DAC to Right Spkr Mixer Enable 0 = disabled 1 = enabled
	1	BYPASSL_TO_MIXSPKR	0	Left Analogue Input to Right Spkr Mixer Enable 0 = disabled 1 = enabled
	0	BYPASSR_TO_MIXSPKR	0	Right Analogue Input to Right Spkr Mixer Enable 0 = disabled 1 = enabled

Register 36h Analogue Spk Mix Right 0



REGISTER ADDRESS	BIT	LABEL	DEFAULT	DESCRIPTION
R55 (37h) Analogue Spk Mix Right 1	3	DACL_MIXSPKR_VOL	0	Left DAC to Right Spkr Mixer volume control 0 = 0dB 1 = -6dB
	2	DACR_MIXSPKR_VOL	0	Right DAC to Right Spkr Mixer volume control 0 = 0dB 1 = -6dB
	1	BYPASSL_MIXSPKR_VOL	0	Left Analogue Input to Right Spkr Mixer volume control 0 = 0dB 1 = -6dB
	0	BYPASSR_MIXSPKR_VOL	0	Right Analogue Input to Right Spkr Mixer volume control 0 = 0dB 1 = -6dB

Register 37h Analogue Spk Mix Right 1

REGISTER ADDRESS	BIT	LABEL	DEFAULT	DESCRIPTION
R57 (39h) Analogue OUT1 Left	8	HPL_MUTE	0	Left Headphone Output Mute 0 = Un-mute 1 = Mute
	7	HPOUTVU	0	Headphone Output Volume Update Writing a 1 to this bit will update HPOUTL and HPOUTR volumes simultaneously.
	6	HPOUTLZC	0	Left Headphone Output Zero Cross Enable 0 = disabled 1 = enabled
	5:0	HPOUTL_VOL [5:0]	10_1101	Left Headphone Output Volume 000000 = -57dB 000001 = -56dB (... 1dB steps) 111001 = 0dB (... 1dB steps) 111110 = +5dB 111111 = +6dB

Register 39h Analogue OUT1 Left

REGISTER ADDRESS	BIT	LABEL	DEFAULT	DESCRIPTION
R58 (3Ah) Analogue OUT1 Right	8	HPR_MUTE	0	Right Headphone Output Mute 0 = Un-mute 1 = Mute
	7	HPOUTVU	0	Headphone Output Volume Update Writing a 1 to this bit will update HPOUTL and HPOUTR volumes simultaneously.
	6	HPOUTRZC	0	Right Headphone Output Zero Cross Enable 0 = disabled 1 = enabled

REGISTER ADDRESS	BIT	LABEL	DEFAULT	DESCRIPTION
	5:0	HPOUTR_VOL [5:0]	10_1101	Right Headphone Output Volume 000000 = -57dB 000001 = -56dB (... 1dB steps) 111001 = 0dB (... 1dB steps) 111110 = +5dB 111111 = +6dB

Register 3Ah Analogue OUT1 Right

REGISTER ADDRESS	BIT	LABEL	DEFAULT	DESCRIPTION
R59 (3Bh) Analogue OUT2 Left	8	LINEOUTL_MUTE	0	Left Line Output Mute 0 = Un-mute 1 = Mute
	7	LINEOUTVU	0	Line Output Volume Update Writing a 1 to this bit will update LINEOUTL and LINEOUTR volumes simultaneously.
	6	LINEOUTLZC	0	Left Line Output Zero Cross Enable 0 = disabled 1 = enabled
	5:0	LINEOUTL_VOL [5:0]	11_1001	Left Line Output Volume 000000 = -57dB 000001 = -56dB (... 1dB steps) 111001 = 0dB (... 1dB steps) 111110 = +5dB 111111 = +6dB

Register 3Bh Analogue OUT2 Left

REGISTER ADDRESS	BIT	LABEL	DEFAULT	DESCRIPTION
R60 (3Ch) Analogue OUT2 Right	8	LINEOUTR_MUTE	0	Right Line Output Mute 0 = Un-mute 1 = Mute
	7	LINEOUTVU	0	Line Output Volume Update Writing a 1 to this bit will update LINEOUTL and LINEOUTR volumes simultaneously.
	6	LINEOUTRZC	0	Right Line Output Zero Cross Enable 0 = disabled 1 = enabled
	5:0	LINEOUTR_VOL [5:0]	11_1001	Right Line Output Volume 000000 = -57dB 000001 = -56dB (... 1dB steps) 111001 = 0dB (... 1dB steps) 111110 = +5dB 111111 = +6dB

Register 3Ch Analogue OUT2 Right

REGISTER ADDRESS	BIT	LABEL	DEFAULT	DESCRIPTION
R62 (3Eh) Analogue OUT3 Left	8	SPKL_MUTE	1	Left Speaker Output Mute 0 = Un-mute 1 = Mute
	7	SPKVU	0	Speaker Output Volume Update Writing a 1 to this bit will update LON/LOP and RON/ROP volumes simultaneously.
	6	SPKLZC	0	Left Speaker Output Zero Cross Enable 0 = disabled 1 = enabled
	5:0	SPKL_VOL [5:0]	11_1001	Left Speaker Output Volume 000000 = -57dB 000001 = -56dB (... 1dB steps) 111001 = 0dB (... 1dB steps) 111110 = +5dB 111111 = +6dB

Register 3Eh Analogue OUT3 Left

REGISTER ADDRESS	BIT	LABEL	DEFAULT	DESCRIPTION
R63 (3Fh) Analogue OUT3 Right	8	SPKR_MUTE	1	Right Speaker Output Mute 0 = Un-mute 1 = Mute
	7	SPKVU	0	Speaker Output Volume Update Writing a 1 to this bit will update LON/LOP and RON/ROP volumes simultaneously.
	6	SPKRZC	0	Right Speaker Output Zero Cross Enable 0 = disabled 1 = enabled
	5:0	SPKR_VOL [5:0]	11_1001	Right Speaker Output Volume 000000 = -57dB 000001 = -56dB (... 1dB steps) 111001 = 0dB (... 1dB steps) 111110 = +5dB 111111 = +6dB

Register 3Fh Analogue OUT3 Right

REGISTER ADDRESS	BIT	LABEL	DEFAULT	DESCRIPTION
R65 (41h) Analogue SPK Output Control 0	1	SPK_DISCHARGE	0	Speaker Discharge Enable 0 = Disabled 1 = Enable
	0	VROI	0	Select VMID_TIE_ENA resistance for disabled Differential Lineouts 0 = 20k ohm 1 = 500 ohm

Register 41h Analogue SPK Output Control 0

REGISTER ADDRESS	BIT	LABEL	DEFAULT	DESCRIPTION
R67 (43h) DC Servo 0	4	DCS_MASTER_EN A	1	DC Servo Master Control 0 = DC Servo Reset 1 = DC Servo Enabled
	3:0	DCS_ENA [3:0]	0000	DC Servo Enable [3] - HPOUTL enable [2] - HPOUTR enable [1] - LINEOUTL enable [0] - LINEOUTR enable

Register 43h DC Servo 0

REGISTER ADDRESS	BIT	LABEL	DEFAULT	DESCRIPTION
R69 (45h) DC Servo 2	1:0	DCS_MODE [1:0]	00	DC Servo Mode 00 = WRITE_STOP 01 = WRITE_UPDATE 10 = START_STOP 11 = START_UPDATE

Register 45h DC Servo 2

REGISTER ADDRESS	BIT	LABEL	DEFAULT	DESCRIPTION
R71 (47h) DC Servo 4	7:0	DCS_HPOUTL_WRITE_VA L [7:0]	0000_0000	Value to send to Left Headphone Output Servo in a WRITE mode Two's complement format. LSB is 0.25mV. Range is +/-32mV

Register 47h DC Servo 4

REGISTER ADDRESS	BIT	LABEL	DEFAULT	DESCRIPTION
R72 (48h) DC Servo 5	7:0	DCS_HPOUTR_WRITE_VA L [7:0]	0000_0000	Value to send to Right Headphone Output Servo in a WRITE mode Two's complement format. LSB is 0.25mV. Range is +/-32mV

Register 48h DC Servo 5

REGISTER ADDRESS	BIT	LABEL	DEFAULT	DESCRIPTION
R73 (49h) DC Servo 6	7:0	DCS_LOUTL_WRITE_VA L [7:0]	0000_0000	Value to send to Left Line Output Servo in a WRITE mode Two's complement format. LSB is 0.25mV. Range is +/-32mV

**Register 49h** DC Servo 6

REGISTER ADDRESS	BIT	LABEL	DEFAULT	DESCRIPTION
R74 (4Ah) DC Servo 7	7:0	DCS_LOUTR_WRITE_VA L [7:0]	0000_0000	Value to send to Right Line Output Servo in a WRITE mode Two's complement format. LSB is 0.25mV. Range is +/-32mV

**Register 4Ah** DC Servo 7

REGISTER ADDRESS	BIT	LABEL	DEFAULT	DESCRIPTION
R81 (51h) DC Servo Readback 1	7:0	DCS_HPOUTL_INTEG [7:0]	0000_0000	Readback value on Left Headphone Output Servo. Two's complement format. LSB is 0.25mV. Range is +/-32mV

**Register 51h** DC Servo Readback 1

REGISTER ADDRESS	BIT	LABEL	DEFAULT	DESCRIPTION
R82 (52h) DC Servo Readback 2	7:0	DCS_HPOUTR_INTEG [7:0]	0000_0000	Readback value on Right Headphone Output Servo. Two's complement format. LSB is 0.25mV. Range is +/-32mV

**Register 52h** DC Servo Readback 2

REGISTER ADDRESS	BIT	LABEL	DEFAULT	DESCRIPTION
R83 (53h) DC Servo Readback 3	7:0	DCS_LOUTL_INTEG [7:0]	0000_0000	Readback value on Left Line Output Servo. Two's complement format. LSB is 0.25mV. Range is +/-32mV

**Register 53h** DC Servo Readback 3

REGISTER ADDRESS	BIT	LABEL	DEFAULT	DESCRIPTION
R84 (54h) DC Servo Readback 4	7:0	DCS_LOUTR_INTEG [7:0]	0000_0000	Readback value on Right Line Output Servo. Two's complement format. LSB is 0.25mV. Range is +/-32mV

Register 54h DC Servo Readback 4

REGISTER ADDRESS	BIT	LABEL	DEFAULT	DESCRIPTION
R90 (54h) Analogue HP 0	7	HPL_RMV_SHORT	0	Removes HPL short 0 = HPL short enabled 1 = HPL short removed For normal operation, this bit should be set as the final step of the HPL Enable sequence.
	6	HPL_ENA_OUTP	0	Enables HPL output stage 0 = Disabled 1 = Enabled For normal operation, this bit should be set to 1 after the DC offset cancellation has been scheduled.
	5	HPL_ENA_DLY	0	Enables HPL intermediate stage 0 = Disabled 1 = Enabled For normal operation, this bit should be set to 1 after the output signal path has been configured, and before DC offset cancellation is scheduled. This bit should be set with at least 20us delay after HPL_ENA.
	4	HPL_ENA	0	Enables HPL input stage 0 = Disabled 1 = Enabled For normal operation, this bit should be set as the first step of the HPL Enable sequence.
	3	HPR_RMV_SHORT	0	Removes HPR short 0 = HPR short enabled 1 = HPR short removed For normal operation, this bit should be set as the final step of the HPR Enable sequence.
	2	HPR_ENA_OUTP	0	Enables HPR output stage 0 = Disabled 1 = Enabled For normal operation, this bit should be set to 1 after the DC offset cancellation has been scheduled.
	1	HPR_ENA_DLY	0	Enables HPR intermediate stage 0 = Disabled 1 = Enabled For normal operation, this bit should be set to 1 after the output signal path has been configured, and before DC offset cancellation is scheduled. This bit should be set with at least 20us delay after HPR_ENA.

REGISTER ADDRESS	BIT	LABEL	DEFAULT	DESCRIPTION
	0	HPR_ENA	0	Enables HPR input stage 0 = Disabled 1 = Enabled For normal operation, this bit should be set as the first step of the HPR Enable sequence.

Register 5Ah Analogue HP 0

REGISTER ADDRESS	BIT	LABEL	DEFAULT	DESCRIPTION
R94 (5Eh) Analogue Lineout 0	7	LINEOUTL_RMV_SHORT	0	Removes LINEOUTL short 0 = LINEOUTL short enabled 1 = LINEOUTL short removed For normal operation, this bit should be set as the final step of the LINEOUTL Enable sequence.
	6	LINEOUTL_ENA_OUTP	0	Enables LINEOUTL output stage 0 = Disabled 1 = Enabled For normal operation, this bit should be set to 1 after the DC offset cancellation has been scheduled.
	5	LINEOUTL_ENA_DLY	0	Enables LINEOUTL intermediate stage 0 = Disabled 1 = Enabled For normal operation, this bit should be set to 1 after the output signal path has been configured, and before DC offset cancellation is scheduled. This bit should be set with at least 20us delay after LINEOUTL_ENA.
	4	LINEOUTL_ENA	0	Enables LINEOUTL input stage 0 = Disabled 1 = Enabled For normal operation, this bit should be set as the first step of the LINEOUTL Enable sequence.
	3	LINEOUTR_RMV_SHORT	0	Removes LINEOUTR short 0 = LINEOUTR short enabled 1 = LINEOUTR short removed For normal operation, this bit should be set as the final step of the LINEOUTR Enable sequence.
	2	LINEOUTR_ENA_OUTP	0	Enables LINEOUTR output stage 0 = Disabled 1 = Enabled For normal operation, this bit should be set to 1 after the DC offset cancellation has been scheduled.
	1	LINEOUTR_ENA_DLY	0	Enables LINEOUTR intermediate stage 0 = Disabled 1 = Enabled For normal operation, this bit should be set to 1 after the output signal path has been configured, and before DC offset cancellation is scheduled. This bit should be set with at least 20us delay after LINEOUTR_ENA.

REGISTER ADDRESS	BIT	LABEL	DEFAULT	DESCRIPTION
	0	LINEOUTR_ENA	0	Enables LINEOUTR input stage 0 = Disabled 1 = Enabled For normal operation, this bit should be set as the first step of the LINEOUTR Enable sequence.

**Register 5Eh** Analogue Lineout 0

REGISTER ADDRESS	BIT	LABEL	DEFAULT	DESCRIPTION
R98 (62h) Charge Pump 0	0	CP_ENA	0	Enable charge-pump digits 0 = disable 1 = enable

**Register 62h** Charge Pump 0

REGISTER ADDRESS	BIT	LABEL	DEFAULT	DESCRIPTION
R104 (68h) Class W 0	0	CP_DYN_PWR	0	Enable dynamic charge pump power control 0 = charge pump controlled by volume register settings 1 = charge pump controlled by real-time audio level

**Register 68h** Class W 0

REGISTER ADDRESS	BIT	LABEL	DEFAULT	DESCRIPTION
R108 (6Ch) Write Sequencer 0	8	WSMD_CLK_ENA	0	Write Sequencer / Mic Detect Clock Enable. 0 = Disabled 1 = Enabled
	4:0	WSEQ_WRITE_INDEX [4:0]	0_0000	Sequence Write Index. This is the memory location to which any updates to R109 and R110 will be copied. 0 to 31 = RAM addresses

**Register 6Ch** Write Sequencer 0

REGISTER ADDRESS	BIT	LABEL	DEFAULT	DESCRIPTION
R109 (6Dh) Write Sequencer 1	14:12	WSEQ_DATA_WIDTH [2:0]	000	Width of the data block written in this sequence step. 000 = 1 bit 001 = 2 bits 010 = 3 bits 011 = 4 bits 100 = 5 bits 101 = 6 bits 110 = 7 bits 111 = 8 bits



REGISTER ADDRESS	BIT	LABEL	DEFAULT	DESCRIPTION
	11:8	WSEQ_DATA_START [3:0]	0000	Bit position of the LSB of the data block written in this sequence step. 0000 = Bit 0 ... 1111 = Bit 15
	7:0	WSEQ_ADDR [7:0]	0000_0000	Control Register Address to be written to in this sequence step.

Register 6Dh Write Sequencer 1

REGISTER ADDRESS	BIT	LABEL	DEFAULT	DESCRIPTION
R110 (6Eh) Write Sequencer 2	14	WSEQ_EOS	0	End of Sequence flag. This bit indicates whether the Control Write Sequencer should stop after executing this step. 0 = Not end of sequence 1 = End of sequence (Stop the sequencer after this step).
	11:8	WSEQ_DELAY [3:0]	0000	Time delay after executing this step. Total delay time per step (including execution)= $62.5\mu\text{s} \times (2^{\text{WSEQ\_DELAY}} + 8)$
	7:0	WSEQ_DATA [7:0]	0000_0000	Data to be written in this sequence step. When the data width is less than 8 bits, then one or more of the MSBs of WSEQ_DATA are ignored. It is recommended that unused bits be set to 0.

Register 6Eh Write Sequencer 2

REGISTER ADDRESS	BIT	LABEL	DEFAULT	DESCRIPTION
R111 (6Fh) Write Sequencer 3	9	WSEQ_ABORT	0	Writing a 1 to this bit aborts the current sequence and returns control of the device back to the serial control interface.
	8	WSEQ_START	0	Writing a 1 to this bit starts the write sequencer at the memory location indicated by the WSEQ_START_INDEX field. The sequence continues until it reaches an "End of sequence" flag. At the end of the sequence, this bit will be reset by the Write Sequencer.
	5:0	WSEQ_START_INDEX [5:0]	00_0000	Sequence Start Index. This is the memory location of the first command in the selected sequence. 0 to 31 = RAM addresses 32 to 48 = ROM addresses 49 to 63 = Reserved

Register 6Fh Write Sequencer 3

REGISTER ADDRESS	BIT	LABEL	DEFAULT	DESCRIPTION
R112 (70h) Write Sequencer 4	9:4	WSEQ_CURRENT_INDEX [5:0]	00_0000	Sequence Current Index. This is the location of the most recently accessed command in the write sequencer memory.
	0	WSEQ_BUSY	0	Sequencer Busy flag (Read Only). 0 = Sequencer idle 1 = Sequencer busy Note: it is not possible to write to control registers via the control interface while the Sequencer is Busy.

Register 70h Write Sequencer 4

REGISTER ADDRESS	BIT	LABEL	DEFAULT	DESCRIPTION
R116 (74h) GPIO Control 1	13:8	GP1_FN [5:0]	00_0000	GPIO 1 Pin Function select 00h = GPIO output 01h = Reserved 02h = IRQ output 03h = GPIO input 04h = MICBIAS Current detect 05h = MICBIAS Short Circuit detect 06h = DMIC_LR Clock output 07h = Reserved 08h = FLL Lock output 09h = FLL Clock output 0Ah to 3Fh = Reserved
	7	GP1_DIR	1	GPIO Pin Direction 0 = Output 1 = Input
	6	GP1_OP_CFG	0	Output pin configuration 0 = CMOS 1 = Open-drain
	5	GP1_IP_CFG	1	Input pin configuration 0 = Active low 1 = Active high
	4	GP1_LVL	0	GPIO Output Level (when GP1_FN = 00000) 0 = Logic 0 1 = Logic 1
	3	GP1_PD	1	GPIO Pull-Down Enable 0 = Pull-down disabled 1 = Pull-down enabled (Approx 100kΩ)
	2	GP1_PU	0	GPIO Pull-Up Enable 0 = Pull-up disabled 1 = Pull-up enabled (Approx 100kΩ)
	1	GP1_INTMODE	0	GPIO Interrupt Mode 0 = Level triggered 1 = Edge triggered
	0	GP1_DB	0	GPIO de-bounce 0 = GPIO is not debounced 1 = GPIO is debounced

Register 74h GPIO Control 1

REGISTER ADDRESS	BIT	LABEL	DEFAULT	DESCRIPTION
R117 (75h) GPIO Control 2	13:8	GP2_FN [5:0]	00_0000	GPIO 2 Pin Function select 00h = GPIO output 01h = Reserved 02h = IRQ output 03h = GPIO input 04h = MICBIAS Current detect 05h = MICBIAS Short Circuit detect 06h = DMIC_DAT Data input 07h = Reserved 08h = FLL Lock output 09h = FLL Clock output 0Ah to 3Fh = Reserved
	7	GP2_DIR	1	GPIO Pin Direction 0 = Output 1 = Input
	6	GP2_OP_CFG	0	Output pin configuration 0 = CMOS 1 = Open-drain
	5	GP2_IP_CFG	1	Input pin configuration 0 = Active low 1 = Active high
	4	GP2_LVL	0	GPIO Output Level (when GP2_FN = 00000) 0 = Logic 0 1 = Logic 1
	3	GP2_PD	1	GPIO Pull-Down Enable 0 = Pull-down disabled 1 = Pull-down enabled (Approx 100kΩ)
	2	GP2_PU	0	GPIO Pull-Up Enable 0 = Pull-up disabled 1 = Pull-up enabled (Approx 100kΩ)
	1	GP2_INTMODE	0	GPIO Interrupt Mode 0 = Level triggered 1 = Edge triggered
	0	GP2_DB	0	GPIO de-bounce 0 = GPIO is not debounced 1 = GPIO is debounced

Register 75h GPIO Control 2

REGISTER ADDRESS	BIT	LABEL	DEFAULT	DESCRIPTION
R118 (76h) GPIO Control 3	13:8	GP3_FN [5:0]	00_0000	GPIO 3 Pin Function select 00h = GPIO output 01h = Reserved 02h = IRQ output 03h = GPIO input 04h = MICBIAS Current detect 05h = MICBIAS Short Circuit detect 06h = Reserved 07h = Reserved 08h = FLL Lock output 09h = FLL Clock output 0Ah to 3Fh = Reserved
	7	GP3_DIR	1	GPIO Pin Direction 0 = Output 1 = Input
	6	GP3_OP_CFG	0	Output pin configuration 0 = CMOS 1 = Open-drain
	5	GP3_IP_CFG	1	Input pin configuration 0 = Active low 1 = Active high
	4	GP3_LVL	0	GPIO Output Level (when GP3_FN = 00000) 0 = Logic 0 1 = Logic 1
	3	GP3_PD	1	GPIO Pull-Down Enable 0 = Pull-down disabled 1 = Pull-down enabled (Approx 100kΩ)
	2	GP3_PU	0	GPIO Pull-Up Enable 0 = Pull-up disabled 1 = Pull-up enabled (Approx 100kΩ)
	1	GP3_INTMODE	0	GPIO Interrupt Mode 0 = Level triggered 1 = Edge triggered
	0	GP3_DB	0	GPIO de-bounce 0 = GPIO is not debounced 1 = GPIO is debounced

Register 76h GPIO Control 3

REGISTER ADDRESS	BIT	LABEL	DEFAULT	DESCRIPTION
R119 (77h) GPIO Control 4	13:8	GP4_FN [5:0]	00_0010	GPIO 4 Pin Function select 00h = GPIO output 01h = Reserved 02h = IRQ output 03h = GPIO input 04h = MICBIAS Current detect 05h = MICBIAS Short Circuit detect 06h = Reserved 07h = Reserved 08h = FLL Lock output 09h = FLL Clock output 0Ah to 3Fh = Reserved
	7	GP4_DIR	0	GPIO Pin Direction 0 = Output 1 = Input
	6	GP4_OP_CFG	0	Output pin configuration 0 = CMOS 1 = Open-drain
	5	GP4_IP_CFG	1	Input pin configuration 0 = Active low 1 = Active high
	4	GP4_LVL	0	GPIO Output Level (when GP4_FN = 00000) 0 = Logic 0 1 = Logic 1
	3	GP4_PD	0	GPIO Pull-Down Enable 0 = Pull-down disabled 1 = Pull-down enabled (Approx 100kΩ)
	2	GP4_PU	0	GPIO Pull-Up Enable 0 = Pull-up disabled 1 = Pull-up enabled (Approx 100kΩ)
	1	GP4_INTMODE	0	GPIO Interrupt Mode 0 = Level triggered 1 = Edge triggered
	0	GP4_DB	0	GPIO de-bounce 0 = GPIO is not debounced 1 = GPIO is debounced

Register 77h GPIO Control 4

REGISTER ADDRESS	BIT	LABEL	DEFAULT	DESCRIPTION
R120 (78h) GPIO Control 5	13:8	GP5_FN [5:0]	00_0001	GPIO 5 Pin Function select 00h = GPIO output 01h = BCLK 02h = IRQ output 03h = GPIO input 04h = MICBIAS Current detect 05h = MICBIAS Short Circuit detect 06h = Reserved 07h = Reserved 08h = FLL Lock output 09h = FLL Clock output 0Ah to 3Fh = Reserved
	7	GP5_DIR	1	GPIO Pin Direction 0 = Output 1 = Input
	6	GP5_OP_CFG	0	Output pin configuration 0 = CMOS 1 = Open-drain
	5	GP5_IP_CFG	1	Input pin configuration 0 = Active low 1 = Active high
	4	GP5_LVL	0	GPIO Output Level (when GP5_FN = 00000) 0 = Logic 0 1 = Logic 1
	3	GP5_PD	0	GPIO Pull-Down Enable 0 = Pull-down disabled 1 = Pull-down enabled (Approx 100kΩ)
	2	GP5_PU	0	GPIO Pull-Up Enable 0 = Pull-up disabled 1 = Pull-up enabled (Approx 100kΩ)
	1	GP5_INTMODE	0	GPIO Interrupt Mode 0 = Level triggered 1 = Edge triggered
	0	GP5_DB	0	GPIO de-bounce 0 = GPIO is not debounced 1 = GPIO is debounced

Register 78h GPIO Control 5

REGISTER ADDRESS	BIT	LABEL	DEFAULT	DESCRIPTION
R121 (79h) Interrupt Status 1	15	MICSHRT_EINT	0	MICBIAS Short Circuit detect IRQ status 0 = Short Circuit current IRQ not set 1 = Short Circuit current IRQ set
	14	MICDET_EINT	0	MICBIAS Current detect IRQ status 0 = Current detect IRQ not set 1 = Current detect IRQ set
	13	WSEQ_BUSY_EINT	0	Write Sequencer Busy IRQ status 0 = WSEQ IRQ not set 1 = WSEQ IRQ set The Write Sequencer asserts this flag when it has completed a programmed sequence - ie it indicates that the Write Sequencer is NOT Busy.
	5	FLL_LOCK_EINT	0	FLL Lock IRQ status 0 = FLL Lock IRQ not set 1 = FLL Lock IRQ set
	4	GP5_EINT	0	GPIO5 IRQ status 0 = GPIO5 IRQ not set 1 = GPIO5 IRQ set
	3	GP4_EINT	0	GPIO4 IRQ status 0 = GPIO4 IRQ not set 1 = GPIO4 IRQ set
	2	GP3_EINT	0	GPIO3/ADDR IRQ status 0 = GPIO3 IRQ not set 1 = GPIO3 IRQ set
	1	GP2_EINT	0	GPIO2/DMIC_DAT IRQ status 0 = GPIO2 IRQ not set 1 = GPIO2 IRQ set
	0	GP1_EINT	0	GPIO1/DMIC_LR IRQ status 0 = GPIO1 IRQ not set 1 = GPIO1 IRQ set

Register 79h Interrupt Status 1

REGISTER ADDRESS	BIT	LABEL	DEFAULT	DESCRIPTION
R122 (7Ah) Interrupt Status 1 Mask	15	IM_MICSHRT_EINT	1	Interrupt mask for MIC Short Circuit Detect 0 = Not masked 1 = Masked
	14	IM_MICDET_EINT	1	Interrupt mask for MIC Current Detect 0 = Not masked 1 = Masked
	13	IM_WSEQ_BUSY_EINT	1	Interrupt mask for WSEQ Busy indication 0 = Not masked 1 = Masked
	5	IM_FLL_LOCK_EINT	1	Interrupt mask for FLL Lock 0 = Not masked 1 = Masked
	4	IM_GP5_EINT	1	Interrupt mask for GPIO5 0 = Not masked 1 = Masked
	3	IM_GP4_EINT	1	Interrupt mask for GPIO4 0 = Not masked 1 = Masked
	2	IM_GP3_EINT	1	Interrupt mask for GPIO3/ADDR 0 = Not masked 1 = Masked
	1	IM_GP2_EINT	1	Interrupt mask for GPIO2/DMIC_DAT 0 = Not masked 1 = Masked
	0	IM_GP1_EINT	1	Interrupt mask for GPIO1/DMIC_LR 0 = Not masked 1 = Masked

Register 7Ah Interrupt Status 1 Mask

REGISTER ADDRESS	BIT	LABEL	DEFAULT	DESCRIPTION
R123 (7Bh) Interrupt Polarity 1	15	MICSHRT_INV	0	MICBIAS Short Circuit detect polarity 0 = Detect current increase above threshold 1 = Detect current decrease below threshold
	14	MICDET_INV	0	MICBIAS Current Detect polarity 0 = Detect current increase above threshold 1 = Detect current decrease below threshold
	5	FLL_LOCK_INV	0	FLL Lock polarity 0 = Non-inverted 1 = Inverted

Register 7Bh Interrupt Polarity 1

REGISTER ADDRESS	BIT	LABEL	DEFAULT	DESCRIPTION
R126 (7Eh) Interrupt Control	0	IRQ_POL	0	Interrupt Output polarity 0 = Active high 1 = Active low

Register 7Eh Interrupt Control



REGISTER ADDRESS	BIT	LABEL	DEFAULT	DESCRIPTION
R128 (80h) FLL Control 1	7:4	FLL_GAIN [3:0]	0000	Gain applied to error 0000 = x 1 (Recommended value) 0001 = x 2 0010 = x 4 0011 = x 8 0100 = x 16 0101 = x 32 0110 = x 64 0111 = x 128 1000 = x 256  Recommended that this register is not changed from default.
	3	FLL_HOLD	0	FLL Hold Select 0 = Disabled 1 = Enabled This feature enables free-running mode in FLL when reference clock is removed
	2	FLL_FRAC	0	Fractional enable 0 = Integer Mode 1 = Fractional Mode  Fractional Mode is recommended in all cases
	0	FLL_ENA	0	FLL Enable 0 = Disabled 1 = Enabled

Register 80h FLL Control 1

REGISTER ADDRESS	BIT	LABEL	DEFAULT	DESCRIPTION
R129 (81h) FLL Control 2	12:11	FLL_CLK_SRC [1:0]	00	FLL Clock source 00 = MCLK 01 = BCLK 10 = LRC 11 = Reserved
	10:9	FLL_CLK_REF_DIV [1:0]	00	FLL Clock Reference Divider 00 = MCLK / 1 01 = MCLK / 2 10 = MCLK / 4 11 = MCLK / 8  MCLK (or other input reference) must be divided down to $\leq 13.5\text{MHz}$ . For lower power operation, the reference clock can be divided down further if desired.
	8:6	FLL_CTRL_RATE [2:0]	000	Frequency of the FLL control block 000 = FVCO / 1 (Recommended value) 001 = FVCO / 2 010 = FVCO / 3 011 = FVCO / 4 100 = FVCO / 5 101 = FVCO / 6 110 = FVCO / 7 111 = FVCO / 8  Recommended that this register is not changed from default.
	5:3	FLL_OUTDIV [2:0]	000	FOUT clock divider 000 = 2 001 = 4 010 = 8 011 = 16 100 = 32 101 = 64 110 = 128 111 = 256  (FOUT = FVCO / FLL_OUTDIV)
	2:0	FLL_FRATIO [2:0]	000	F <sub>VCO</sub> clock divider 000 = divide by 1 001 = divide by 2 010 = divide by 4 011 = divide by 8 1XX = divide by 16  000 recommended for F <sub>REF</sub> > 1MHz 100 recommended for F <sub>REF</sub> < 64kHz

Register 81h FLL Control 2

REGISTER ADDRESS	BIT	LABEL	DEFAULT	DESCRIPTION
R130 (82h) FLL Control 3	15:0	FLL_K [15:0]	0000_0000 _0000_000 0	Fractional multiply for FREF (MSB = 0.5)

**Register 82h** FLL Control 3

REGISTER ADDRESS	BIT	LABEL	DEFAULT	DESCRIPTION
R131 (83h) FLL Control 4	9:0	FLL_N [9:0]	00_0000_0 000	Integer multiply for FREF (LSB = 1)

**Register 83h** FLL Control 4

REGISTER ADDRESS	BIT	LABEL	DEFAULT	DESCRIPTION
R164 (A4h) Clock Rate Test 4	9	ADC_DIG_MIC	0	Enables Digital Microphone mode. 0 = Audio DSP input is from ADC 1 = Audio DSP input is from digital microphone interface

**Register A4h** Clock Rate Test 4

REGISTER ADDRESS	BIT	LABEL	DEFAULT	DESCRIPTION
R172 (ACh) Analogue Output Bias 0	6:4	PGA_BIAS [2:0]	000	Headphone and Lineout PGA bias control 000 = Normal bias 001 = Normal bias x 1.5 010 = Normal bias x 0.75 011 = Normal bias x 0.5 100 = Normal bias x 0.33 101 = Normal bias 110 = Normal bias 111 = Normal bias x 2

**Register ACh** Analogue Output Bias 0

REGISTER ADDRESS	BIT	LABEL	DEFAULT	DESCRIPTION
R187 (BBh) Analogue Output Bias 2	2:0	OUTPUTS_BIAS [2:0]	000	Headphone and Lineout Output Drivers bias control 000 = Normal bias 001 = Normal bias x 1.5 010 = Normal bias x 0.75 011 = Normal bias x 0.5 100 = Normal bias x 0.33 101 = Normal bias 110 = Normal bias 111 = Normal bias x 2

**Register BBh** Analogue Output Bias 2

APPLICATIONS INFORMATION

RECOMMENDED EXTERNAL COMPONENTS

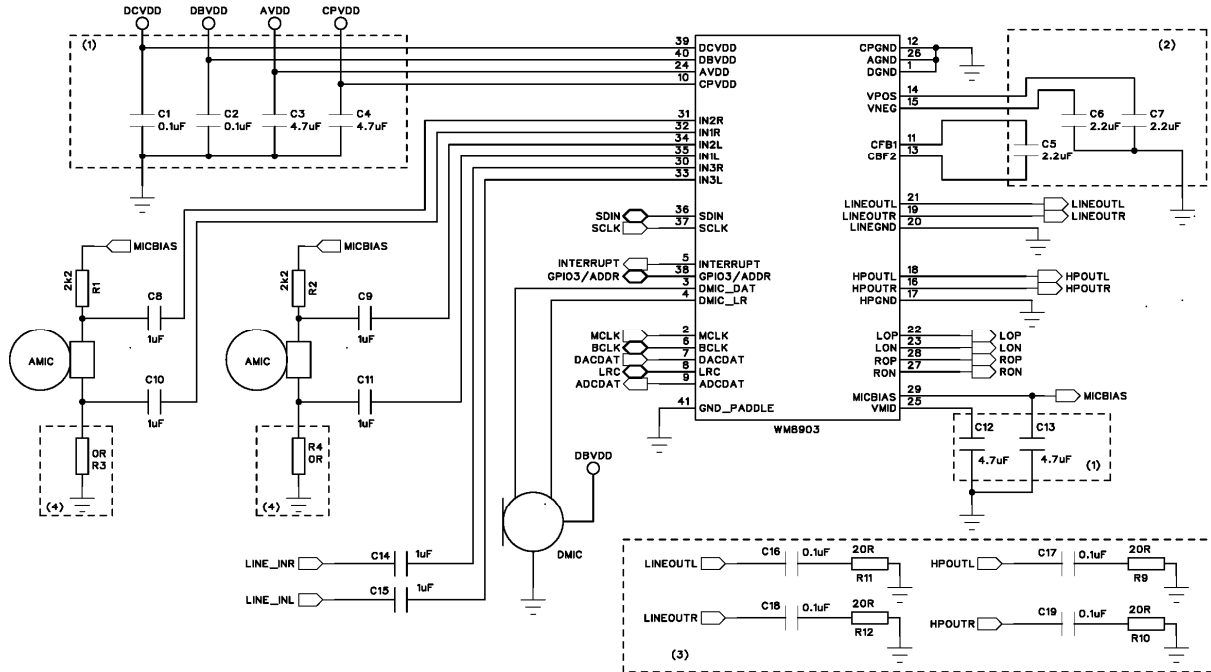


Figure 67 Recommended External Components

Notes:

1. Decoupling Capacitors

X5R ceramic capacitor is recommended for capacitors C1, C2, C3, C4, C6, C7, C12 and C13.

All decoupling capacitors should be positioned as close to the WM8903 as possible.

The positioning of C12 and C13 is particularly important - these should be as close to the WM8903 as possible.

2. Charge Pump Capacitors

Specific recommendations for C5, C6 and C7 are provided in Table 85. Note that two different recommendations are provided for these components; either of these components is suitable, depending upon size requirements and availability.

The positioning of C5 is very important - this should be as close to the WM8903 as possible.

It is important to select a suitable capacitor type for the Charge Pump. Note that the capacitance may vary with DC voltage; care is required to ensure that required capacitance is achieved at the applicable operating voltage, as specified in Table 85. The capacitor datasheet should be consulted for this information.

COMPONENT	REQUIRED CAPACITANCE	VALUE	PART NUMBER	VOLTAGE	TYPE	SIZE
C5 (CFB1-CFB2)	≥ 1µF at 2VDC	2.2µF	Kemet C0402C225M9PAC	6.3v	X5R	0402
		2.2µF	MuRata GRM155R60J225ME15_EIA	6.3v	X5R	0402
C6 (VNEG) C7 (VPOS)	≥ 2µF at 2VDC	2.2µF	MuRata GRM188R61A225KE34D	10v	X5R	0603
		4.7µF	MuRata GRM155R60J475M_EIA	6.3v	X5R	0402

Table 85 Charge Pump Capacitors

**3. Zobel Networks**

The Zobel network shown in Figure 67 is required on HPOUTL, HPOUTR, LINEOUTL and LINEOUTR whenever that output is enabled. Stability of these ground-referenced outputs across all process corners cannot be guaranteed without the Zobel network components. (Note that, if any ground-referenced output pin is not required, the zobel network components can be omitted from the output pin, and the pin can be left floating.) The Zobel network requirement is detailed further in the applications note WAN\_0212 "Class W Headphone Impedance Compensation".

Zobel networks (CC16, C17, C18, C19, R9, R10, R11, R12) should be positioned reasonably close to the WM8903.

**4. Microphone Grounding**

R3 and R4 can be populated with other values to remove common mode noise on the microphone if required.

### MIC DETECTION SEQUENCE USING MICBIAS CURRENT

This section details an example sequence which summarises how the host processor can configure and detect the events supported by the MICBIAS current detect function (see “Electret Condenser Microphone Interface”):

- Mic insertion/removal
- Hook switch press/release

Figure 68 shows an example of how the MICBIAS current flow varies versus time, during mic insertion and hook switch events. The Y axis is annotated with the Mic detection thresholds, and the X axis is annotated with the stages of an example sequence as detailed in Table 86, to illustrate how the host processor can implement mic insertion and hook switch detection.

The sequence assumes that the microphone insertion and hook switch detection functions are monitored by polling the interrupt flags using the control interface. Note that the maximum mechanical bounce times for mic insertion and removal must be fully understood by the software programmer.

A GPIO pin could be used as an alternative mechanism to monitor the MICBIAS detection functions. This enables the host processor to detect mechanical bounce at any time.

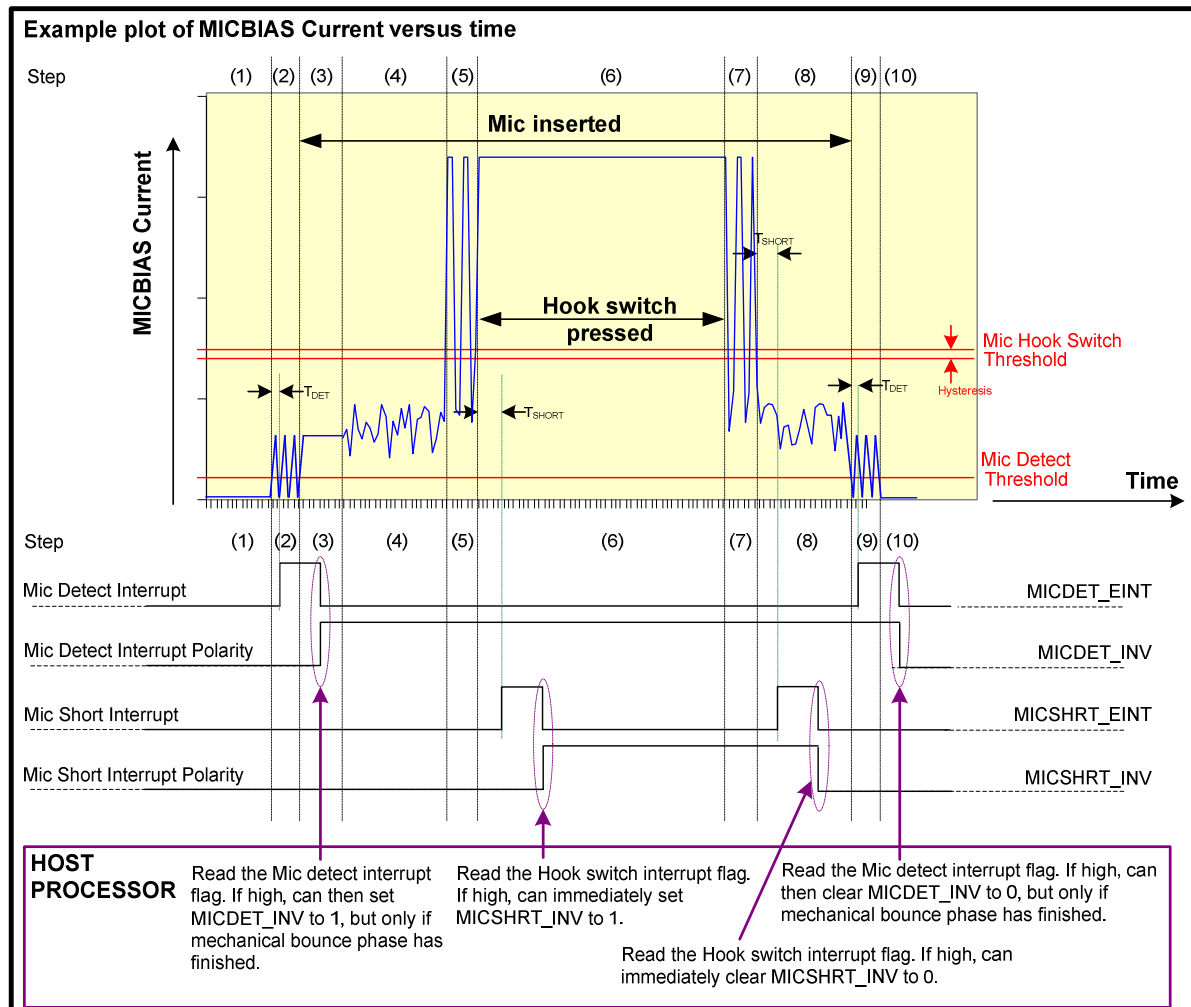


Figure 68 Mic Insert and Hook Switch Detect: Example MICBIAS Current Plot

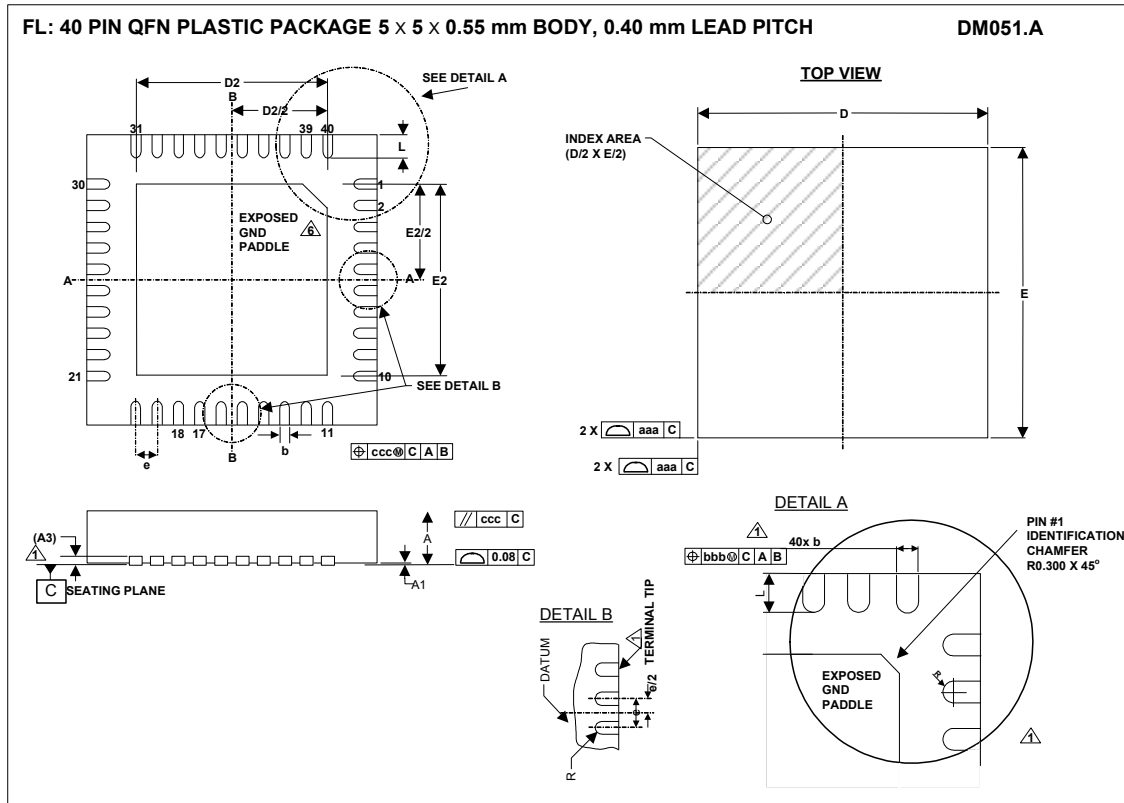
STEP	DETAILS
1	Mic not inserted. To detect mic insertion, Host processor must initialise interrupts and clear MICDET_INV = 0. At every step, the host processor should poll the interrupt status register.
2	Mechanical bounce of jack socket during Mic insertion. Host processor may already detect a mic insertion interrupt (MICDET_EINT) during this step. Once detected, the host processor can set MICDET_INV = 1, unless mechanical bounce can last longer than the shortest possible $T_{DET}$ , in which case the host processor should not set MICDET_INV = 1 until step 3.
3	Mic fully inserted. If not already set, the host processor must now set MICDET_INV = 1. To detect Hook switch press, the host processor must clear MICSHRT_INV = 0. At this step, the diagram shows no AC current swing, due to a very low ambient noise level.
4	Mic fully inserted. Diagram shows AC current swing due to high levels of background noise (such as wind).
5	Mechanical bounce during hook switch press. The hook switch interrupt is unlikely to be set during this step, because 10 successive samples of the MICBIAS current exceeding the hook switch threshold have not yet been sampled.
6	Hook switch is fully pressed down. After $T_{SHORT}$ , 10 successive samples of the MICBIAS current exceeding the hook switch threshold have been detected, hence a hook switch interrupt (MICSHRT_EINT) will be generated, and the host processor can immediately set MICSHRT_INV = 1.
7	Mechanical bounce during hook switch release. The hook switch interrupt is unlikely to be set during this step, because 10 successive samples of the MICBIAS current lower than the hook switch threshold have not yet been sampled.
8	Hook switch fully released. After $T_{SHORT}$ , 10 successive samples of the MICBIAS current lower than the hook switch threshold have been detected, hence a hook switch interrupt (MICSHRT_EINT) will be generated, and the host processor can immediately clear MICSHRT_INV = 0.
9	Mechanical bounce of jack socket during Mic removal. Host processor may already detect a mic removal interrupt (MICDET_EINT) during this step. Once detected, the host processor can clear MICDET_INV = 0, unless mechanical bounce can last longer than the shortest possible $T_{DET}$ , in which case the host processor should not clear MICDET_INV = 0 until step 10.
10	Mic fully removed. If not already cleared, the host processor must now clear MICDET_INV = 0.

**Table 86 Mic Insert and Hook Switch Detect: Example Sequence**

Alternatively, utilising a GPIO pin to monitor the MICBIAS current detect functionality permits the host processor to monitor the steady state of microphone detection or hook switch press functions. Because the GPIO shows the steady state condition, software de-bounce may be easier to implement in the host processor, dependant on the processor performance characteristics, hence use of the GPIO is likely to simplify the rejection of mechanical bounce. Changes of state in the GPIO pin are also subject to the time delays  $t_{DET}$  and  $t_{SHORT}$ .

Further details can be found in the applications note WAN\_0213 "WM8903 ECM mic detection using MICBIAS current".

PACKAGE DIMENSIONS



Symbols	Dimensions (mm)			NOTE
	MIN	NOM	MAX	
A	0.50	0.55	0.60	
A1	0	0.02	0.05	
A3		0.203 REF		
b	0.15	0.20	0.25	1
D		5.00 BSC		
D2	3.55	3.6	3.65	2
E		5.00 BSC		
E2	3.55	3.6	3.65	2
e		0.4 BSC		
L	0.35	0.4	0.45	
<b>Tolerances of Form and Position</b>				
aaa		0.15		
bbb		0.10		
ccc		0.10		
REF:	JEDEC, MO-220			

- NOTES:
1. DIMENSION b APPLIED TO METALLIZED TERMINAL AND IS MEASURED BETWEEN 0.25 mm AND 0.30 mm FROM TERMINAL TIP.
  2. FALLS WITHIN JEDEC, MO-220.
  3. ALL DIMENSIONS ARE IN MILLIMETRES
  4. THIS DRAWING IS SUBJECT TO CHANGE WITHOUT NOTICE.
  5. REFER TO APPLICATIONS NOTE WAN\_0118 FOR FURTHER INFORMATION.



## IMPORTANT NOTICE

Wolfson Microelectronics plc ("Wolfson") products and services are sold subject to Wolfson's terms and conditions of sale, delivery and payment supplied at the time of order acknowledgement.

Wolfson warrants performance of its products to the specifications in effect at the date of shipment. Wolfson reserves the right to make changes to its products and specifications or to discontinue any product or service without notice. Customers should therefore obtain the latest version of relevant information from Wolfson to verify that the information is current.

Testing and other quality control techniques are utilised to the extent Wolfson deems necessary to support its warranty. Specific testing of all parameters of each device is not necessarily performed unless required by law or regulation.

In order to minimise risks associated with customer applications, the customer must use adequate design and operating safeguards to minimise inherent or procedural hazards. Wolfson is not liable for applications assistance or customer product design. The customer is solely responsible for its selection and use of Wolfson products. Wolfson is not liable for such selection or use nor for use of any circuitry other than circuitry entirely embodied in a Wolfson product.

Wolfson's products are not intended for use in life support systems, appliances, nuclear systems or systems where malfunction can reasonably be expected to result in personal injury, death or severe property or environmental damage. Any use of products by the customer for such purposes is at the customer's own risk.

Wolfson does not grant any licence (express or implied) under any patent right, copyright, mask work right or other intellectual property right of Wolfson covering or relating to any combination, machine, or process in which its products or services might be or are used. Any provision or publication of any third party's products or services does not constitute Wolfson's approval, licence, warranty or endorsement thereof. Any third party trade marks contained in this document belong to the respective third party owner.

Reproduction of information from Wolfson datasheets is permissible only if reproduction is without alteration and is accompanied by all associated copyright, proprietary and other notices (including this notice) and conditions. Wolfson is not liable for any unauthorised alteration of such information or for any reliance placed thereon.

Any representations made, warranties given, and/or liabilities accepted by any person which differ from those contained in this datasheet or in Wolfson's standard terms and conditions of sale, delivery and payment are made, given and/or accepted at that person's own risk. Wolfson is not liable for any such representations, warranties or liabilities or for any reliance placed thereon by any person.

## ADDRESS

Wolfson Microelectronics plc

Westfield House

26 Westfield Road

Edinburgh

EH11 2QB

Tel :: +44 (0)131 272 7000

Fax :: +44 (0)131 272 7001

Email :: [sales@wolfsonmicro.com](mailto:sales@wolfsonmicro.com)