

Linear	Desktop
Enclosed or L Bracket	Open Frame
PCB Mount	Rack Mount Hot Swap

AC-DC Selector

Applications	# of Outputs	Output Power (W)											
		5	10	15	30	50	100	300	500	1000	1500	2500	
High Reliability Industrial (Five Year Warranty)	Single				NNS								
					HWS								
							JWS						
									LZSA				
	Dual			NND									
	Triple					JWT							
Industrial (Three Year Warranty)	Single & Multiple			HK-A (Single Output, 115VAC input)									
								NV					
					MTW								
									Vega				
											Alpha		
Datacom Commercial (One - Two Year Warranty)	Single		KW, KPS, KM										
			ZWS, ZWSAF, ZWSPAF										
					DT								
					H								
					SC, SC120, ZP								
							SWS						
								PFE					
									FPS (1U)				
									TH (1U)				
		Multiple		KW, KM									
					LWD, LWT								
					H								
					DT								
				SC, ZP									
						ZWD, ZWQ							
Programmable	Single							ZUP					
DIN Rail Mount	Single				DSP, DPP, DLP-PU*								
							DLP						

* See website

CSS65 Series

2 x 4" 40 to 65W AC-DC Medical Power Supplies



RoHS

- ◆ Wide Range AC Input
- ◆ Low profile, Industry Standard Footprint
- ◆ Global Safety Agency Compliance

Key Market Segments & Applications

Medical
Gaming
Test and Measurement

Features and Benefits

Feature	Benefit
◆ Industry standard footprint	◆ Availability to second source
◆ Wide Range AC Input	◆ Global Operation
◆ Dual input fuses	◆ Easier system compliance

Specifications

ITEMS		CSS65
Input Voltage range	V	90 - 264VAC (47 - 63Hz) or 120 - 370VDC
Inrush Current	A	<40A maximum at 115VAC input, 25oC ambient cold start
Input Current (115/230VAC)	A	2 / 1
Leakage Current	uA	<250uA 264VAC 63Hz
Hold Up Time (Typ)	ms	10ms at 115VAC input
Temperature Coefficient	°C	±0.05%/°C
Adjustment Range	-	None
Remote Sense	-	Yes
Minimum Load	A	None
Regulation	%	5V: ±5%, 12-24V: ±3%, 36-48V: ±2% (10 - 100% load change, 100-240VAC line change)
Ripple & Noise	%	1% whichever is greater
Short Circuit Protection	-	Continuous - hiccup mode
Overvoltage Protection	V	110 - 150% of nominal (Automatic Reset)
Efficiency	%	80% typical
Operating Temperature	°C	0 to +70°C derate linearly to 50% load from 50 to 70°C
Storage Temperature	°C	-10 to +70°C
Humidity (non condensing)	-	20 - 95% RH
Cooling	-	Convection
Withstand Voltage	-	Input to Ground 1.5kVAC, Input to Output 4kVAC, Output to Ground 500VDC for 1 min.
Isolation Resistance	-	>20M at 25C & 70%RH, Output to Ground 500VDC
Vibration (non operating)	-	23.52m/s ² (10 - 55Hz: constant sweep 1 min X, Y, Z for 1 hour)
Shock	-	< 196.1 m/s ² (20G)
Safety Agency Approvals	-	UL60601-1, EN60601-1, IEC60601-1, CE Mark
Conducted & Radiated EMI	-	EN55011-B, FCC Class B
Immunity	-	EN60601-1-2
Weight (Typ)	g	200g
Size (WxLxH)	in	2 x 4 x 1.18" (including underside components)
Warranty	yr	One Year

CSS65 Series

Model Selector

Model	Output (V)	Maximum Output (A)	Maximum Power (W)
CSS65-5	5	8.0	40
CSS65-12	12	5.0	60
CSS65-15	15	4.0	60
CSS65-19	19	3.43	65
CSS65-24	24	2.71	65
CSS65-36	36	1.81	65
CSS65-48	48	1.36	65

Other Lambda Industrial Products

KM	15 - 40W pcb mount medical
NV175	175 - 200W 1-4 outputs
NV300	300W 1-4 outputs

Outline Drawings

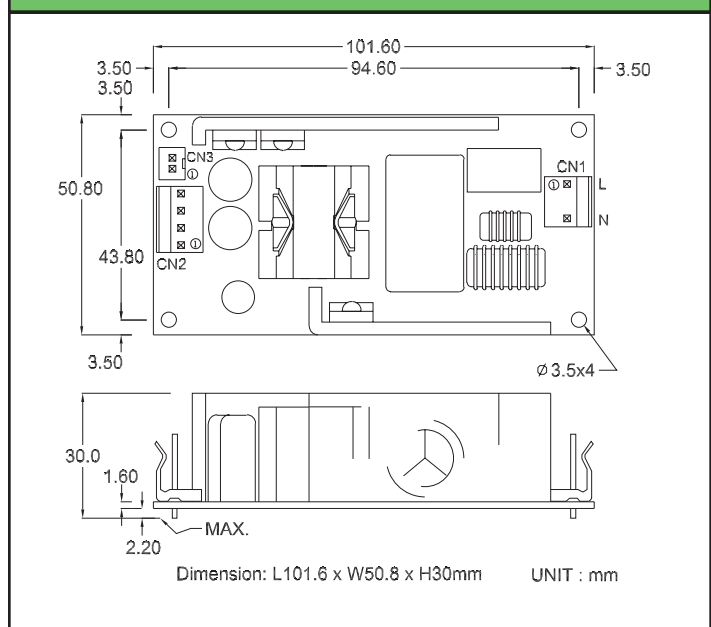

- ◆ Input Connector mates with Molex Housing 09-50-3031 or equivalent
- ◆ Output Connector mates with Molex Housing 09-50-3041 or equivalent