



# STEVAL-IFD001V1

## Full USB dongle based on STR912

Data Brief

### Features

- 42x GPIOs
- 8x ADC
- 3x UARTs
- 2x SPI
- I2C
- CAN
- USB slave (full-speed)
- Ethernet (STE100 or STE10)

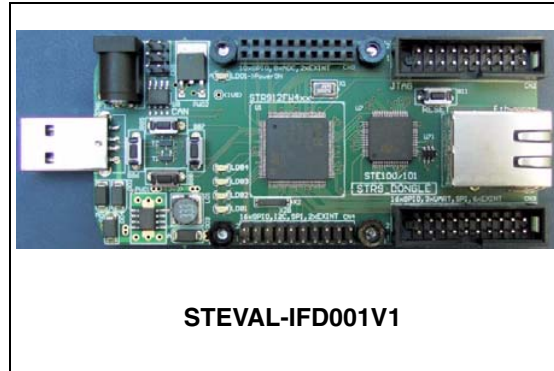

### Description

This board is a general-purpose development platform for all applications based on the STR912 ARM 9 core microcontroller. It can be also used as a UART-SPI-I2C-USB-CAN-ETHERNET bridge. The board can be extended with options of a MEMS, Flash memory and an LCD display. The MEMS (micro-electromechanical-system) extension enables the sensing of 2 or 3-axial motion (acceleration or vibration). Both analog and digital sensors are supported. The Flash extension allows up to 1 Gbyte of memory to be added to the application. This additional memory can be connected through a parallel interface and is accessible through a Flash memory driver on board. The LCD extension allows most popular LCD displays to be connected to the main board. For more information please refer to the document UM0282.

# 1 Block diagram

This board is based on STR912FW4xx which provides calculation power up to 90MIPS.

**Figure 1. STR9 dongle block diagram**

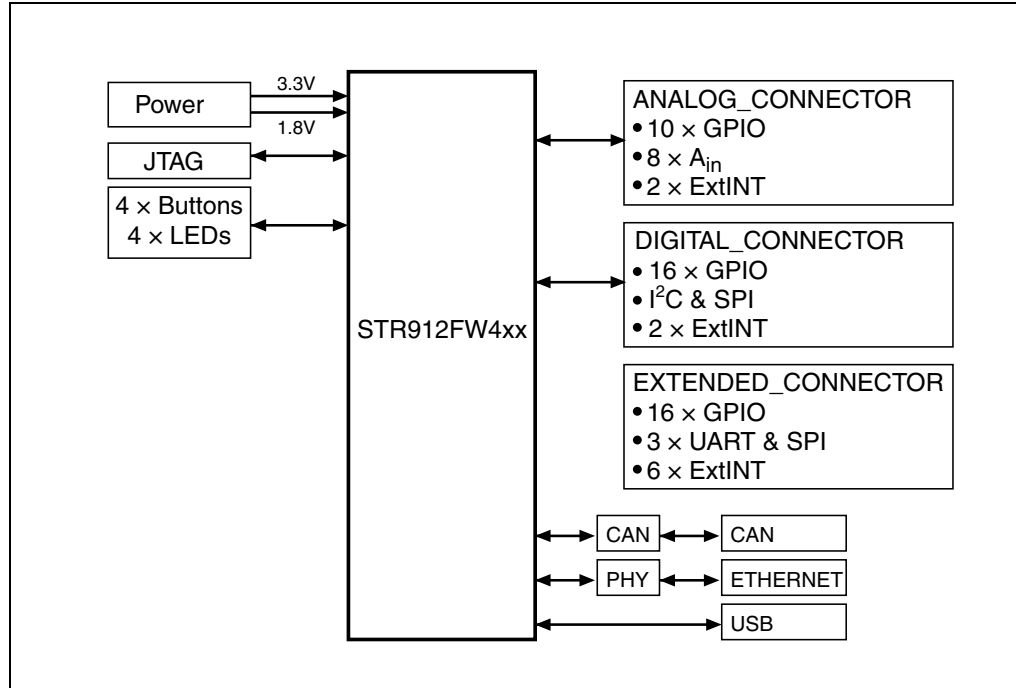

# 2 Schematics

Figure 2. Schematics 1 of 4

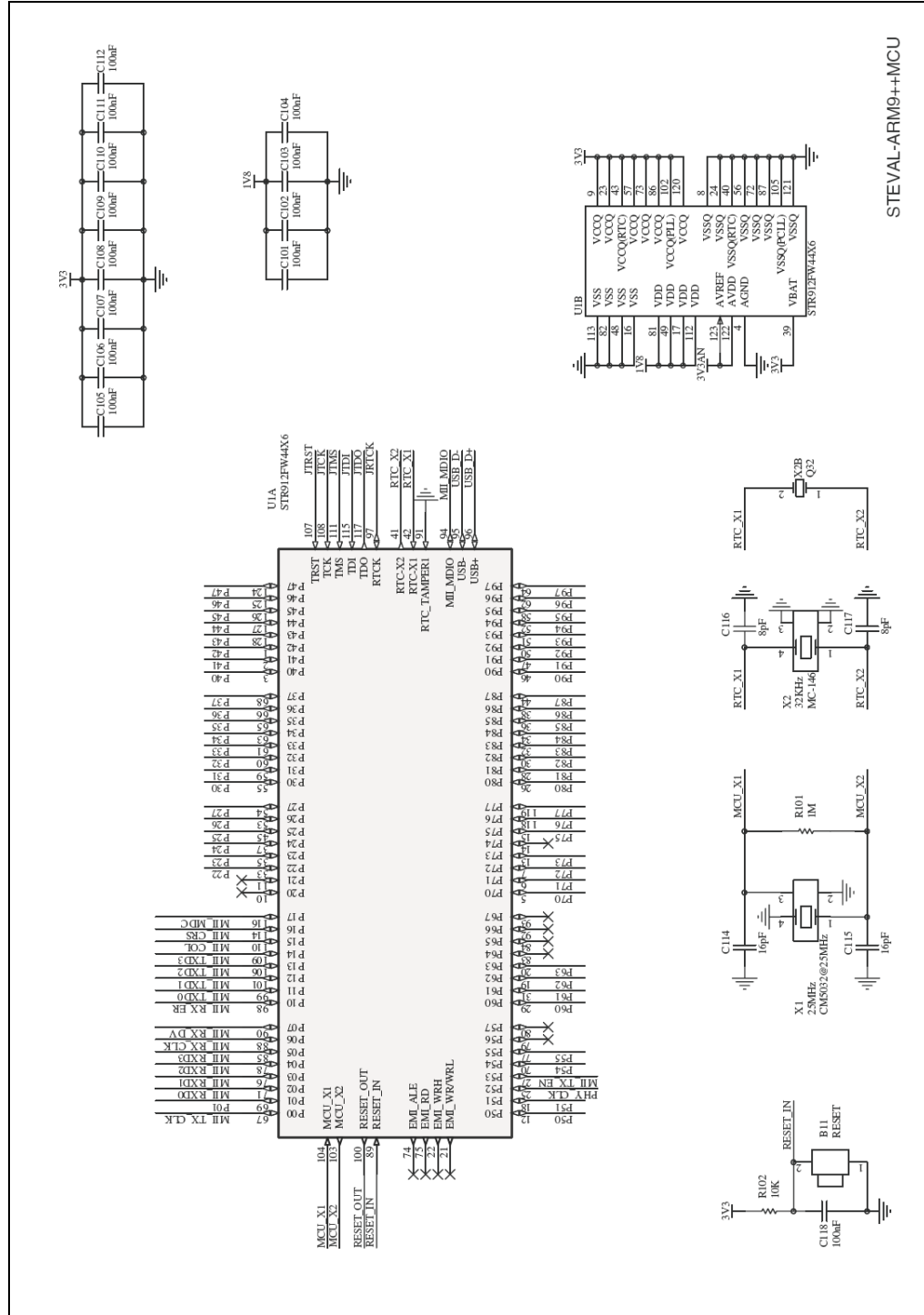
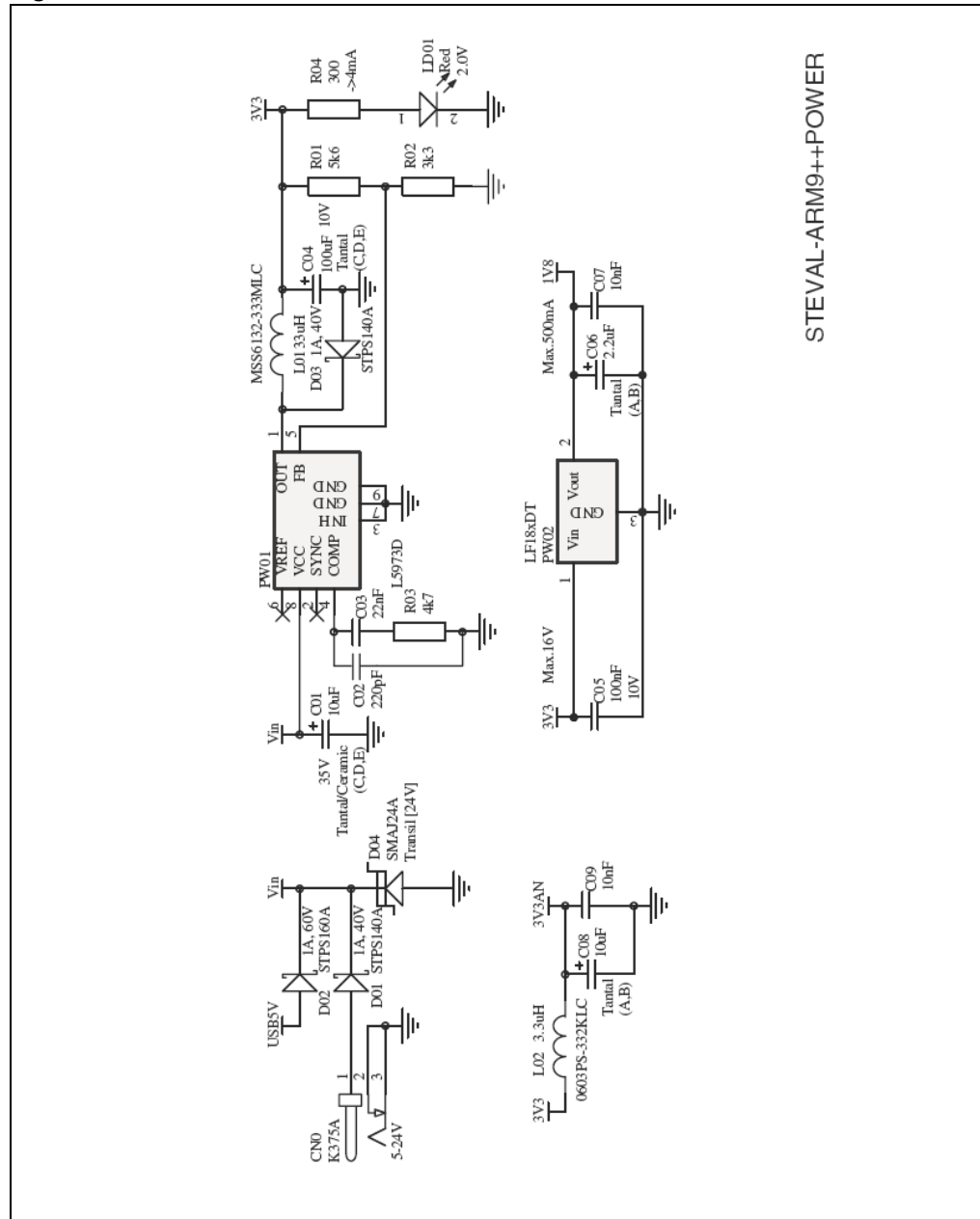
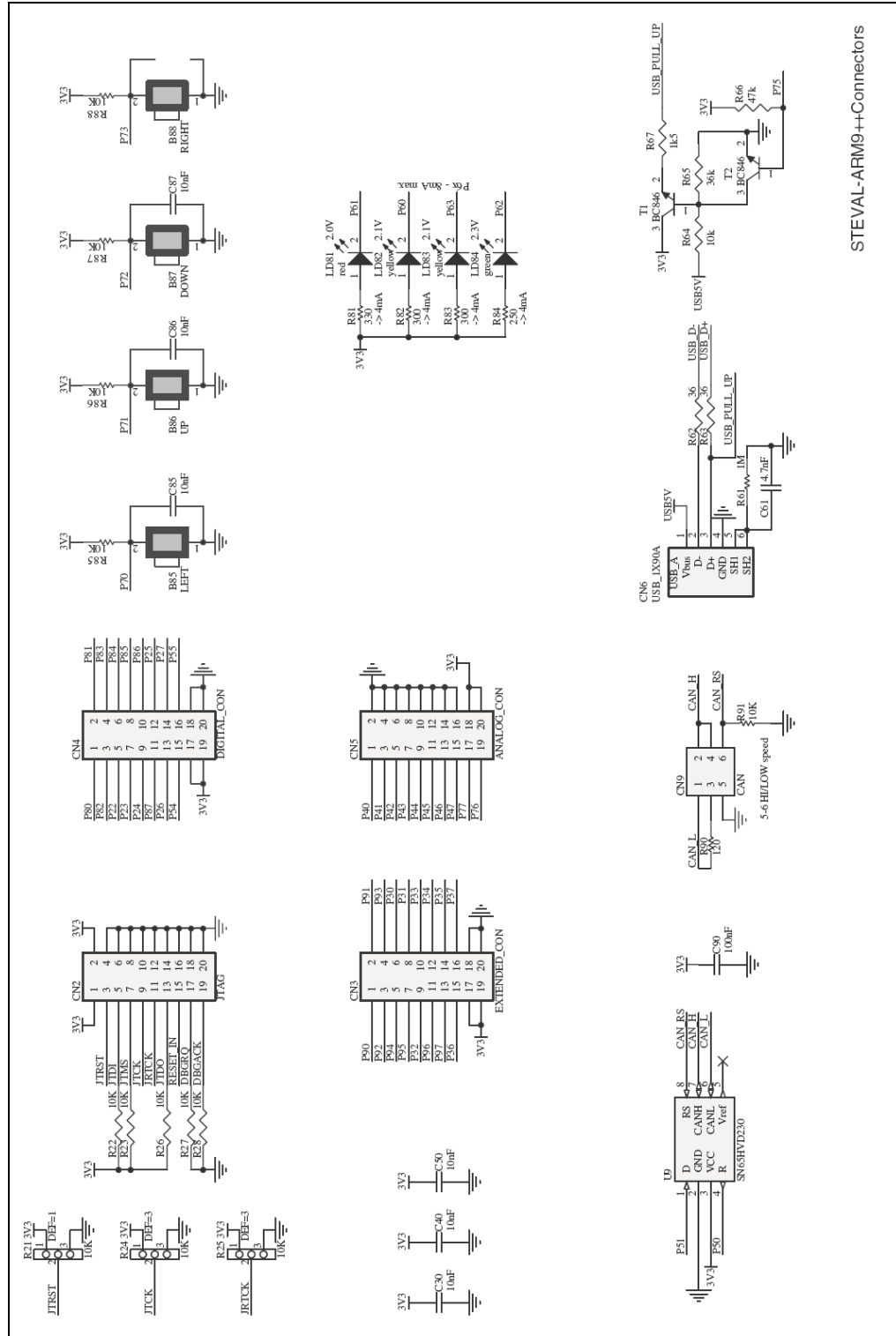

Figure 3. Schematics 2 of 4



STEVAL-ARM9++POWER

Figure 4. Schematics 3 of 4



STEVAL-ARM9++Connectors

Figure 5. Schematics 4 of 4

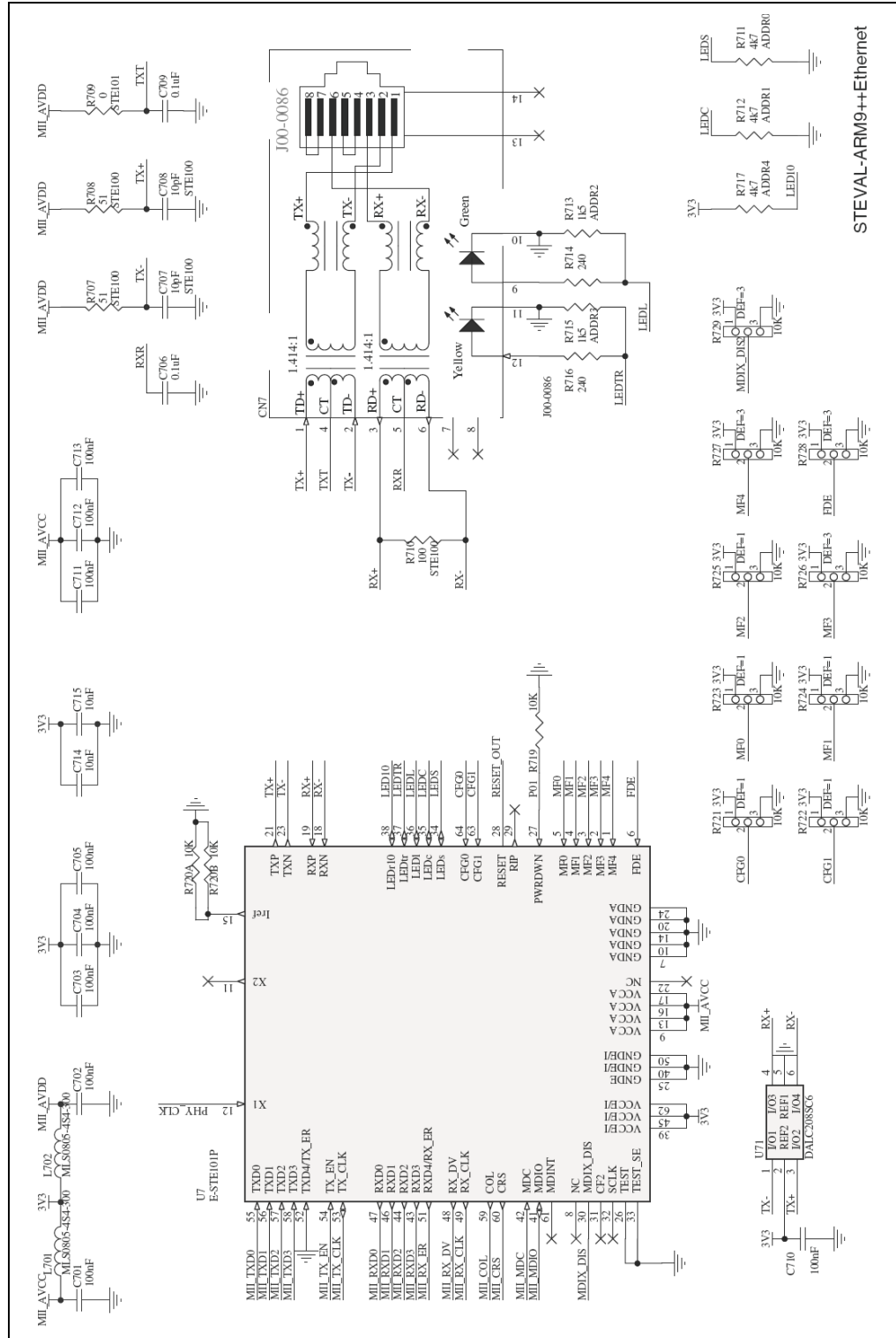

STEVAL-ARM9++Ethernet



### 3 Revision history

Table 1. Document revision history

Date	Revision	Changes
22-Oct-2007	1	Initial release

**Please Read Carefully:**

Information in this document is provided solely in connection with ST products. STMicroelectronics NV and its subsidiaries ("ST") reserve the right to make changes, corrections, modifications or improvements, to this document, and the products and services described herein at any time, without notice.

All ST products are sold pursuant to ST's terms and conditions of sale.

Purchasers are solely responsible for the choice, selection and use of the ST products and services described herein, and ST assumes no liability whatsoever relating to the choice, selection or use of the ST products and services described herein.

No license, express or implied, by estoppel or otherwise, to any intellectual property rights is granted under this document. If any part of this document refers to any third party products or services it shall not be deemed a license grant by ST for the use of such third party products or services, or any intellectual property contained therein or considered as a warranty covering the use in any manner whatsoever of such third party products or services or any intellectual property contained therein.

**UNLESS OTHERWISE SET FORTH IN ST'S TERMS AND CONDITIONS OF SALE ST DISCLAIMS ANY EXPRESS OR IMPLIED WARRANTY WITH RESPECT TO THE USE AND/OR SALE OF ST PRODUCTS INCLUDING WITHOUT LIMITATION IMPLIED WARRANTIES OF MERCHANTABILITY, FITNESS FOR A PARTICULAR PURPOSE (AND THEIR EQUIVALENTS UNDER THE LAWS OF ANY JURISDICTION), OR INFRINGEMENT OF ANY PATENT, COPYRIGHT OR OTHER INTELLECTUAL PROPERTY RIGHT.**

**UNLESS EXPRESSLY APPROVED IN WRITING BY AN AUTHORIZED ST REPRESENTATIVE, ST PRODUCTS ARE NOT RECOMMENDED, AUTHORIZED OR WARRANTED FOR USE IN MILITARY, AIR CRAFT, SPACE, LIFE SAVING, OR LIFE SUSTAINING APPLICATIONS, NOR IN PRODUCTS OR SYSTEMS WHERE FAILURE OR MALFUNCTION MAY RESULT IN PERSONAL INJURY, DEATH, OR SEVERE PROPERTY OR ENVIRONMENTAL DAMAGE. ST PRODUCTS WHICH ARE NOT SPECIFIED AS "AUTOMOTIVE GRADE" MAY ONLY BE USED IN AUTOMOTIVE APPLICATIONS AT USER'S OWN RISK.**

Resale of ST products with provisions different from the statements and/or technical features set forth in this document shall immediately void any warranty granted by ST for the ST product or service described herein and shall not create or extend in any manner whatsoever, any liability of ST.

ST and the ST logo are trademarks or registered trademarks of ST in various countries.

Information in this document supersedes and replaces all information previously supplied.

The ST logo is a registered trademark of STMicroelectronics. All other names are the property of their respective owners.

© 2007 STMicroelectronics - All rights reserved

STMicroelectronics group of companies

Australia - Belgium - Brazil - Canada - China - Czech Republic - Finland - France - Germany - Hong Kong - India - Israel - Italy - Japan - Malaysia - Malta - Morocco - Singapore - Spain - Sweden - Switzerland - United Kingdom - United States of America

[www.st.com](http://www.st.com)