

## Smallest Class of Safety Limit Switches in the World

**Note:** Contact your sales representative for details on models with safety standard certification.



- The world's smallest limit switch with a direct opening mechanism (four-contact construction model).
- High-sensitivity safety limit switch.
- Built-in switches with two- or four-contact construction are available.
- Degree of protection: IP67 (EN60947-5-1)
- Certified standards: UL, EN (TÜV), and CCC

**!** Be sure to read the "Safety Precautions" on page 6 and the "Precautions for All Safety Limit Switches".



## Model Number Structure

### Model Number Legend

D4F-□□-□□  
1 2 3 4

- Built-in Switch**
  - 1: 1NC/1NO (slow-action)
  - 2: 2NC (slow-action)
  - 3: 2NC/2NO (slow-action)
  - 4: 4NC (slow-action)
- Actuator**
  - 02: Roller plunger (Metal roller)
  - 20: Roller lever (Metal lever, resin roller)
- Cable Length**
  - 1: 1 m
  - 3: 3 m
  - 5: 5 m
- Pull-outting direction of cable**
  - R: Horizontal
  - D: Vertical

## Ordering Information

### List of Models

#### Safety Limit Switches (with Direct Opening Mechanism)

Consult with your OMRON representative when ordering any models that are not listed in this table.

Actuator	Cable length	Pull-outting direction of cable	Built-in switch							
			1NC/1NO (slow-action)		2NC (slow-action)		2NC/2NO (slow-action)		4NC (slow-action)	
			Model	Direct opening	Model	Direct opening	Model	Direct opening	Model	Direct opening
Roller lever (Metal lever, resin roller)	1 m	Horizontal	D4F-120-1R	→	D4F-220-1R	→	D4F-320-1R	→	D4F-420-1R	→
		Vertical	D4F-120-1D	→	D4F-220-1D	→	D4F-320-1D	→	D4F-420-1D	→
	3 m	Horizontal	D4F-120-3R	→	D4F-220-3R	→	D4F-320-3R	→	D4F-420-3R	→
		Vertical	D4F-120-3D	→	D4F-220-3D	→	D4F-320-3D	→	D4F-420-3D	→
	5 m	Horizontal	D4F-120-5R	→	D4F-220-5R	→	D4F-320-5R	→	D4F-420-5R	→
		Vertical	D4F-120-5D	→	D4F-220-5D	→	D4F-320-5D	→	D4F-420-5D	→
Roller plunger (Metal roller)	1 m	Horizontal	D4F-102-1R	→	D4F-202-1R	→	D4F-302-1R	→	D4F-402-1R	→
		Vertical	D4F-102-1D	→	D4F-202-1D	→	D4F-302-1D	→	D4F-402-1D	→
	3 m	Horizontal	D4F-102-3R	→	D4F-202-3R	→	D4F-302-3R	→	D4F-402-3R	→
		Vertical	D4F-102-3D	→	D4F-202-3D	→	D4F-302-3D	→	D4F-402-3D	→
	5 m	Horizontal	D4F-102-5R	→	D4F-202-5R	→	D4F-302-5R	→	D4F-402-5R	→
		Vertical	D4F-102-5D	→	D4F-202-5D	→	D4F-302-5D	→	D4F-402-5D	→

## Specifications

### Standards and EC Directives

Conforms to the following EC Directives:

- Machinery Directive
- Low Voltage Directive
- EN60204-1
- EN1088
- EN50047
- EN81
- EN115
- GS-ET-15
- JIS C 8201-5-1

### Certified Standards

Certification body	Standards	File No.
TÜV SÜD	EN60947-5-1 (certified direct opening)	*1
UL *2	UL508 CSA C22.2 No.14	E76675
CQC (CCC) *3	GB14048.5	20030103050 64266

\*1. Contact your OMRON sales representative.

\*2. Certification has been obtained for CSA C22.2 No. 14 under UL.

\*3. Ask your OMRON representative for information on certified models.

### Certified Standard Ratings

TÜV (EN60947-5-1), CCC (GB14048.5)

Item	Utilization category	AC-15	DC-13
Rated operating current ( $I_e$ )		0.75 A	0.27 A
Rated operating voltage ( $U_e$ )		240 V	250 V

**Note:** Use a 10 A fuse type gI or gG that conforms to IEC60269 as a short-circuit protection device.

UL/CSA (UL508, CSA C22.2 No. 14)

#### C300

Rated voltage	Carry current	Current (A)		Volt-amperes (VA)	
		Make	Break	Make	Break
120 VAC 240 VAC	2.5 A	15 7.5	1.5 0.75	1,800	180

#### Q300

Rated voltage	Carry current	Current (A)		Volt-amperes (VA)	
		Make	Break	Make	Break
125 VDC 250 VDC	2.5 A	0.55 0.27	0.55 0.27	69	69

## Characteristics

Degree of protection *1		IP67 (EN60947-5-1)
Durability *2	Mechanical	10,000,000 times min.
	Electrical	1,000,000 times min. (4 mA resistive load at 24 VDC, 4 circuits) 150,000 times min. (1 A resistive load at 125 VAC, 2 circuits/4 mA resistive load at 24 VDC, 2 circuits) *3
Operating speed		1 mm/s to 0.5 m/s
Operating frequency	Mechanical	120 operations/minute
	Electrical	30 operations/minute
Contact resistance *5		300 mΩ max. (with 1 m cable), 500 mΩ max. (with 3 m cable), 700 mΩ max. (with 5 m cable)
Minimum applicable load *4		4 mA resistive load at 24 VDC, 4 circuits (N-level reference value)
Rated insulation voltage (U <sub>i</sub> )		250 V
Rated frequency		50/60 Hz
Protection against electric shock		Class I (with a ground wire)
Pollution degree (operating environment)		3 (EN60947-5-1)
Impulse withstand voltage (EN60947-5-1)	Between terminals of same polarity	2.5 kV
	Between terminals of different polarity	4 kV
	Between each terminal and ground	4 kV
Insulation resistance		100 MΩ min. (at 500 VDC) between terminals of the same polarities, between terminals of different polarities, between current-carrying metal parts and grounds, and between each terminal and non-current carrying metal parts
Contact gap		2 × 2 mm min.
Vibration resistance	Malfunction	10 to 55 Hz, 0.75 mm single amplitude
Shock resistance	Destruction	1,000 m/s <sup>2</sup> min.
	Malfunction	300 m/s <sup>2</sup> min.
Conditional short-circuit current		100 A (EN60947-5-1)
Conventional free air thermal current (I <sub>th</sub> )		2.5 A (EN60947-5-1)
Ambient operating temperature		-30 to 70°C (with no icing)
Ambient operating humidity		95% max.
Cable		UL2464 No. 22 AWG, finishing O.D.: 8.3 mm
Weight		Approx. 190 g (D4F-102-1R, with 1 m cable) Approx. 220 g (D4F-120-1R, with 1 m cable)

**Note: 1.** The above values are initial values.

**2.** Once the contact is opened or closed with an ordinary load, it cannot be used for a load smaller than that. The contact surface may be rough, which impairs the reliability of contacting.

\*1. The degree of protection shown above is based on the test method specified in EN60947-5-1. Be sure to confirm in advance the sealing performance under the actual operating environment and conditions.

\*2. Durability values are calculated at an operating temperature of 5 to 35°C, and an operating humidity of 40% to 70%. Contact your OMRON sales representative for more detailed information on other operating environments.

\*3. Do not apply 1 A at 125 VAC to more than two circuits.

\*4. The value will vary depending on factors such as the switching frequency, the ambient environment, and the reliability level. Be sure to confirm correct operation with the actual load before application.

\*5. The contact resistance was measured with 0.1 A at 5 to 8 VDC with a fall-of-potential method.

# Structure and Nomenclature

## Structure

### Lever

Improved safety of the lever-setting (Form lock configuration). Many grooves are incised on the lever and the rotating shaft that mesh with each other to prevent a slip between the lever and the rotating shaft. The lever can be set for positioning in steps of 9 degrees.

### Built-in Switch

Has a direct opening mechanism separating the contacts when the NC contacts are welded.

### Head

The plunger type of actuator can be used in a normal direction and reverse direction.

### Cable

The cable can be pulled out in a horizontal direction or in a vertical direction.

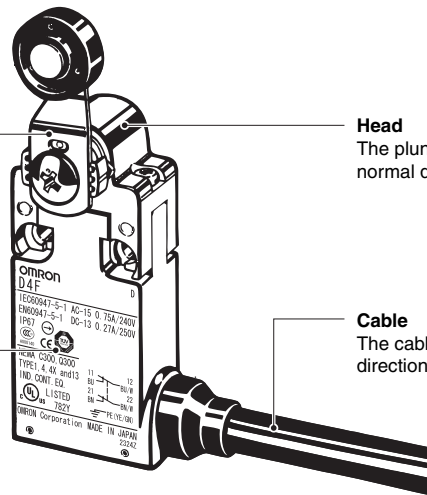

## Direct Opening Mechanism

### 1NC/1NO Contact (slow-action)

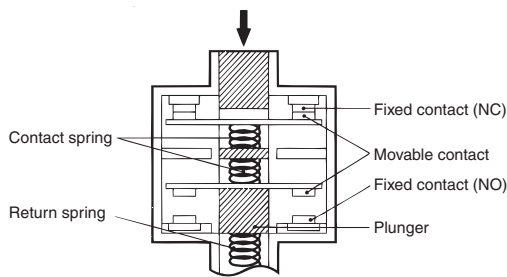

Conforms to EN60947-5-1 Direct Opening  $\rightarrow$ .

(Only the NC contacts have a direct opening function.)

When contact welding occurs, the NC contacts are separated from each other by pushing in the plunger.

## Contact Form

Model	Contact	Contact form	Operating pattern	Remarks
D4F-1□-□□	1NC/1NO (slow-action)			<p>Only NC contact 11-12 has a certified direct opening mechanism. <math>\rightarrow</math></p> <p>The terminals 11-12 and 33-34 can be used as unlike poles.</p>
D4F-2□-□□	2NC (slow-action)			<p>NC contacts 11-12 and 21-22 have a certified direct opening mechanism. <math>\rightarrow</math></p> <p>The terminals 11-12 and 21-22 can be used as unlike poles.</p>
D4F-3□-□□	2NC/2NO (slow-action)			<p>NC contacts 11-12 and 21-22 have a certified direct opening mechanism. <math>\rightarrow</math></p> <p>The terminals 11-12, 21-22, 33-34 and 43-44 can be used as unlike poles.</p>
D4F-4□-□□	4NC (slow-action)			<p>NC contacts 11-12, 21-22, 31-32 and 41-42 have a certified direct opening mechanism. <math>\rightarrow</math></p> <p>The terminals 11-12, 21-22, 31-32 and 41-42 can be used as unlike poles.</p>

**Note:** Terminal numbers are according to EN50013; contact symbols are according to IEC60947-5-1.

# Dimensions and Operating Characteristics

(Unit: mm)

**Roller lever (Metal lever, resin roller)**  
D4F-□20-□R

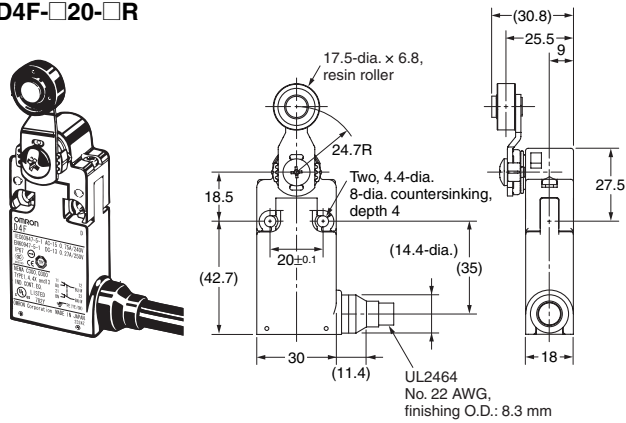

**Roller plunger (Metal roller)**  
D4F-□02-□R

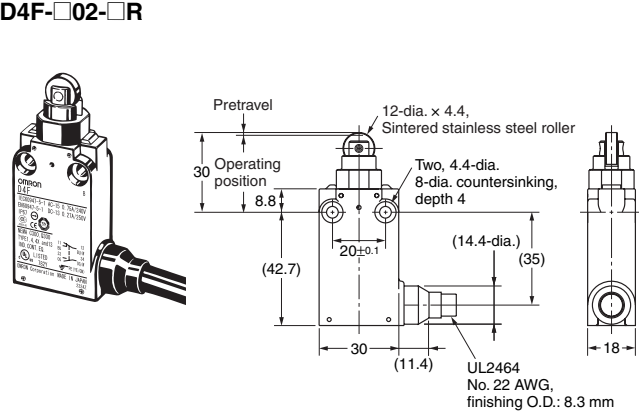

**Roller lever (Metal lever, resin roller)**  
D4F-□20-□D

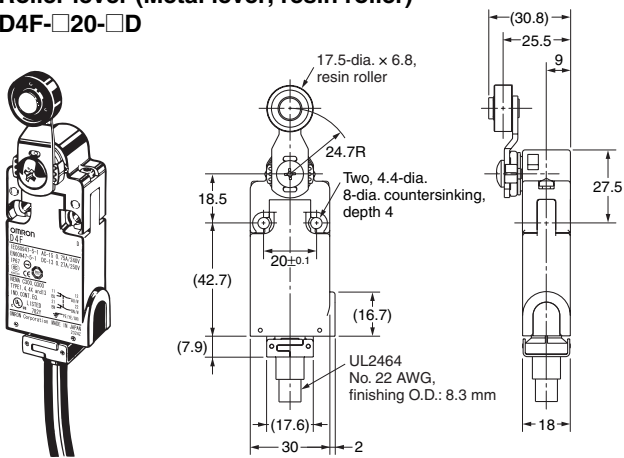

**Roller plunger (Metal roller)**  
D4F-□02-□D

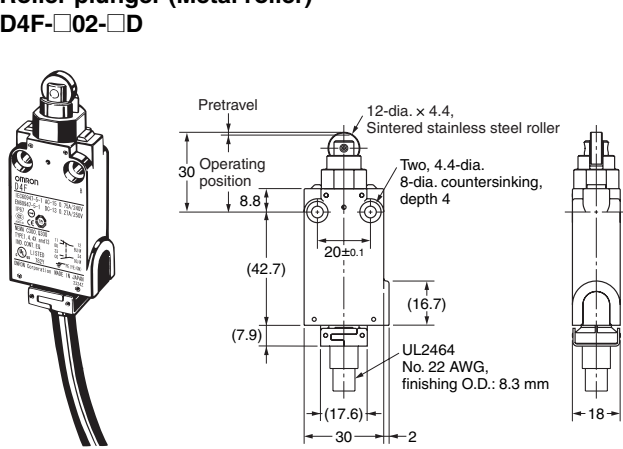

**Note:** Each dimension has a tolerance of 0.4 mm unless otherwise specified.

## Slow-action (1NC/1NO), (2NC), (2NC/2NO), and (4NC)

Operating Characteristics		Model	D4F-□20-□R D4F-□20-□D	D4F-□02-□R D4F-□02-□D
Operating force	OF max. *1		5 N	12 N
Release force	RF min. *2		0.5 N	1.5 N
Pretravel	PT1 (11-12 and 21-22)		6±3° (NC)	1 mm max. (NC)
	PT1 (31-32 and 41-42)		9±3° (NC)	1.3 mm max. (NC)
	PT2 *3		(12°) (NO)	(1.2 mm) (NO)
Overtravel	OT min.		40°	3.2 mm
Operating position	OP (11-12 and 21-22)		---	29.4±1 mm
	OP (31-32 and 41-42)		---	29±1 mm
Total travel	TT *3		(55°)	(4.5 mm)
Direct opening travel	DOT min. *4		18°	1.8 mm
Direct opening force	DOF min.		20 N	20 N

**Note:** Variation occurs in the simultaneity of contact opening/closing operations of 2NC, 2NC/2NO, and 4NC contacts. Check contact operation.

\*1. The OF value is the maximum load that opens an NC contact (11-12, 21-22, 31-32, 41-42).

\*2. The RF value is the minimum load that closes an NC contact (11-12, 21-22, 31-32, 41-42).

\*3. The PT2 and TT values are reference values.

\*4. The D4F is used in accordance with EN81 and EN115 at a minimum DOT of 30° and 2.8 mm.

## Safety Precautions

Refer to the “*Precautions for All Switches*” and “*Precautions for All Safety Limit Switches*”.

### Precautions for Safe Use

- Do not use more than one D4F side-by-side.
- Do not switch circuits for two or more standard loads (250 VAC, 3 A). Doing so may adversely affect insulation performance.

### Handling of Cables

- Cables cannot be flexed repeatedly.
- The cable is fixed with sealing materials on the bottom of the switch. When excessive force may be imposed on the cable, fasten the cable with a fixing unit at a distance of 50 mm from the bottom of the switch as shown.
- Do not pull or press the cable at an excessive force (50 N max.).
- When bending the cable, secure the cable with more than 45 mm bending radius so as not to cause damage to the insulator or sheath of the cable. Doing so may result in current leakage or burning.

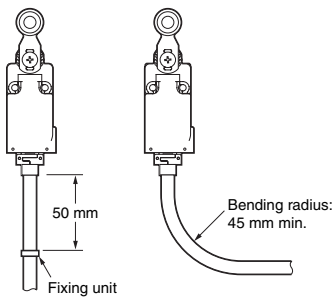

- When wiring, be sure to prevent penetration of a liquid such as water or oil through the cable end.

### Operating Environment

- Do not use the Switch submerged in oil or water or in locations continuously subject to splashes of oil or water. Doing so may result in oil or water entering the Switch. (The IP67 degree of protection of the Switch specifies the amount of water penetration after the Switch is submerged in water for a certain period of time.)

### Precautions for Correct Use

The Switch contacts can be used with either standard loads or microloads. Once the contacts have been used to switch a load, however, they cannot be used to switch smaller loads. The contact surfaces will become rough once they have been used and contact reliability for smaller loads may be reduced.

### Appropriate Tightening Torque

Be sure to tighten each screw of the D4F properly, otherwise the D4F may soon malfunction

No.	Type	Appropriate tightening torque
1	Lever mounting screw (M5)	2.4 to 2.8 N·m
2	Body mounting screw (M4)	1.18 to 1.37 N·m

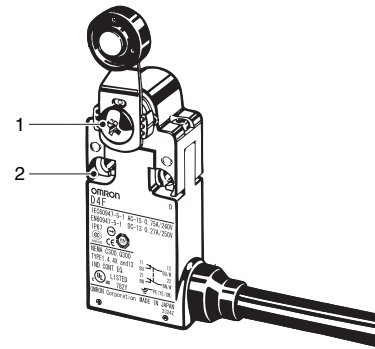

### Mounting

Use two M4 screws and washers to mount the D4F securely. The D4F can be mounted more securely with proper tightening torque.

#### Mounting Holes (Unit: mm)

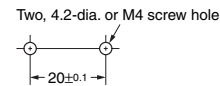

### Changing the Lever Angle

- Unfasten the screw that holds the lever to set the position of the lever at any angle through 360° (in steps of 9°).
- After unfastening the screws that hold the lever, mount the lever the other way (normal side or reverse side). Set an angle of the lever to complete adjustment within a range in which the lever does not touch the switch body.

## Wiring

### Identifying Wires

Identify wires according to the color (with or without white lines) of the insulation on the wire.

#### Cross section

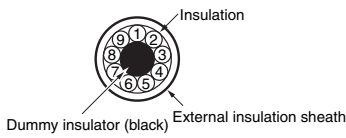

#### Core Insulator Colors

Blue/white, Orange/white, Pink/white, Brown/white, Green/yellow, Brown, Pink, Orange, and Blue  
Example: Blue/white is a blue insulator with a white line.

### Terminal Numbers

- Identify terminal numbers based on the color (with or without white lines) of the insulation on the wire.
- The safety and auxiliary contacts of D4F models of four-terminal contact construction and those of two-terminal contact construction are described below.
- The safety contacts are direct-opening NC contacts (11-12 and 21-22); they are used for safety circuits, and each of them is indicated with the appropriate mark  $\ominus$ .
- Auxiliary contacts are used to check (to monitor) the operating state of the switch, which are equivalent to NO contacts (33-34 and 43-44) or NC contacts (31-32 and 41-42).
- The NC contacts 31-32 and 41-42 of auxiliary contacts (orange or pink) can be used as safety contacts.

#### <1NC/1NO>

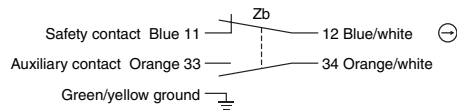

#### <2NC>

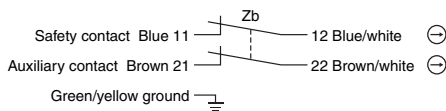

#### <2NC/2NO>

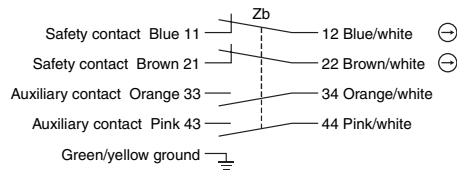

#### <4NC>

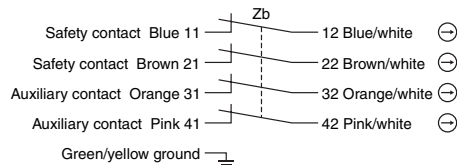

#### Note: Safety Contacts:

The safety contacts are direct opening contacts certified by EN and each of them is indicated with the mark  $\ominus$ .

- Cut the dummy core insulator and all unused wires at the end of the external insulation sheath when wiring the cable.

## Operating

- To set the plunger stroke correctly, press-fit the plunger until the top of the pushing surface comes between two grooves on the plunger.

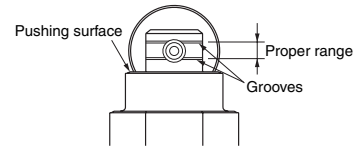

- To set the roller lever stroke correctly, push the dog and cam until the lance point comes within the range of the convex part that is the correct setting position.

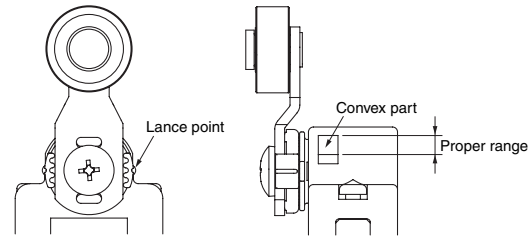

## Others

- Actuating the switch from an angle other than 90 degrees to the switch face may deform or damage the actuator, or deform or damage the rotary spindle, so make sure that the dog is straight.

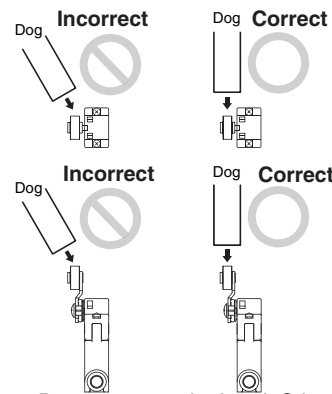

- Do not remove the head. Otherwise, a failure may occur.
- To avoid telegraphing, take the following precautions.

- Modify the rear end of the dog to an angle of 15° to 30° as shown below or to a secondary-degree curve.



- Modify the circuit so as not to detect the wrong operating signals.

## Read and Understand This Catalog

Please read and understand this catalog before purchasing the products. Please consult your OMRON representative if you have any questions or comments.

## Warranty and Limitations of Liability

### WARRANTY

OMRON's exclusive warranty is that the products are free from defects in materials and workmanship for a period of one year (or other period if specified) from date of sale by OMRON.

OMRON MAKES NO WARRANTY OR REPRESENTATION, EXPRESS OR IMPLIED, REGARDING NON-INFRINGEMENT, MERCHANTABILITY, OR FITNESS FOR PARTICULAR PURPOSE OF THE PRODUCTS. ANY BUYER OR USER ACKNOWLEDGES THAT THE BUYER OR USER ALONE HAS DETERMINED THAT THE PRODUCTS WILL SUITABLY MEET THE REQUIREMENTS OF THEIR INTENDED USE. OMRON DISCLAIMS ALL OTHER WARRANTIES, EXPRESS OR IMPLIED.

### LIMITATIONS OF LIABILITY

OMRON SHALL NOT BE RESPONSIBLE FOR SPECIAL, INDIRECT, OR CONSEQUENTIAL DAMAGES, LOSS OF PROFITS OR COMMERCIAL LOSS IN ANY WAY CONNECTED WITH THE PRODUCTS, WHETHER SUCH CLAIM IS BASED ON CONTRACT, WARRANTY, NEGLIGENCE, OR STRICT LIABILITY.

In no event shall the responsibility of OMRON for any act exceed the individual price of the product on which liability is asserted.

IN NO EVENT SHALL OMRON BE RESPONSIBLE FOR WARRANTY, REPAIR, OR OTHER CLAIMS REGARDING THE PRODUCTS UNLESS OMRON'S ANALYSIS CONFIRMS THAT THE PRODUCTS WERE PROPERLY HANDLED, STORED, INSTALLED, AND MAINTAINED AND NOT SUBJECT TO CONTAMINATION, ABUSE, MISUSE, OR INAPPROPRIATE MODIFICATION OR REPAIR.

## Application Considerations

### SUITABILITY FOR USE

OMRON shall not be responsible for conformity with any standards, codes, or regulations that apply to the combination of products in the customer's application or use of the products.

At the customer's request, OMRON will provide applicable third party certification documents identifying ratings and limitations of use that apply to the products. This information by itself is not sufficient for a complete determination of the suitability of the products in combination with the end product, machine, system, or other application or use.

The following are some examples of applications for which particular attention must be given. This is not intended to be an exhaustive list of all possible uses of the products, nor is it intended to imply that the uses listed may be suitable for the products:

- Outdoor use, uses involving potential chemical contamination or electrical interference, or conditions or uses not described in this catalog.
- Nuclear energy control systems, combustion systems, railroad systems, aviation systems, medical equipment, amusement machines, vehicles, safety equipment, and installations subject to separate industry or government regulations.
- Systems, machines, and equipment that could present a risk to life or property.

Please know and observe all prohibitions of use applicable to the products.

NEVER USE THE PRODUCTS FOR AN APPLICATION INVOLVING SERIOUS RISK TO LIFE OR PROPERTY WITHOUT ENSURING THAT THE SYSTEM AS A WHOLE HAS BEEN DESIGNED TO ADDRESS THE RISKS, AND THAT THE OMRON PRODUCTS ARE PROPERLY RATED AND INSTALLED FOR THE INTENDED USE WITHIN THE OVERALL EQUIPMENT OR SYSTEM.

### PROGRAMMABLE PRODUCTS

OMRON shall not be responsible for the user's programming of a programmable product, or any consequence thereof.

## Disclaimers

### CHANGE IN SPECIFICATIONS

Product specifications and accessories may be changed at any time based on improvements and other reasons.

It is our practice to change model numbers when published ratings or features are changed, or when significant construction changes are made. However, some specifications of the products may be changed without any notice. When in doubt, special model numbers may be assigned to fix or establish key specifications for your application on your request. Please consult with your OMRON representative at any time to confirm actual specifications of purchased products.

### DIMENSIONS AND WEIGHTS

Dimensions and weights are nominal and are not to be used for manufacturing purposes, even when tolerances are shown.

### PERFORMANCE DATA

Performance data given in this catalog is provided as a guide for the user in determining suitability and does not constitute a warranty. It may represent the result of OMRON's test conditions, and the users must correlate it to actual application requirements. Actual performance is subject to the OMRON Warranty and Limitations of Liability.

### ERRORS AND OMISSIONS

The information in this document has been carefully checked and is believed to be accurate; however, no responsibility is assumed for clerical, typographical, or proofreading errors, or omissions.

2009.3

In the interest of product improvement, specifications are subject to change without notice.

**OMRON Corporation**  
Industrial Automation Company

<http://www.ia.omron.com/>

(c)Copyright OMRON Corporation 2009 All Right Reserved.