

# 6N138, 6N139

Current Loop Driver.  
 Low Input Current Line Receiver.  
 CMOS Logic Interface.

The TOSHIBA 6N138 and 6N139 consists of a GaAlAs infrared emitting diode coupled with a split-Darlington output configuration. A high speed GaAlAs Ired manufactured with an unique LPE junction, has the virtue of fast rise and fall time at low drive current.

- Isolation voltage: 2500Vrms (min.)
- Current transfer ratio
  - : 6N138 - 300% (min.) (IF=1.6mA)
  - : 6N139 - 400% (min.) (IF=0.5mA)
- Switching time: 6N138 - tPHL=10µs (max.)
  - tPLH=35µs (max.)
  - 6N139 - tPHL=1µs (max.)
  - tPLH=7µs (max.)
- UL recognized: UL1577, file no. E67349

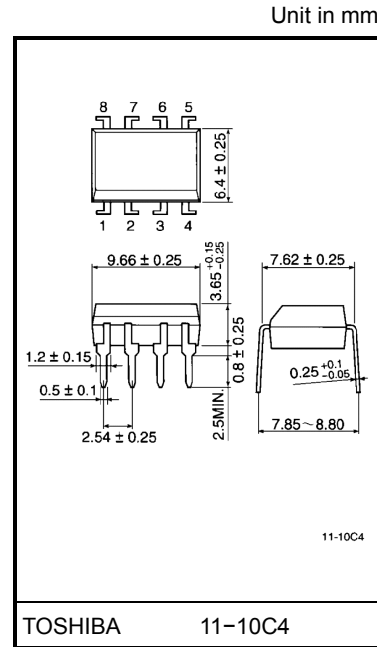

Weight: 0.54 g

## Pin Configuration (top view)

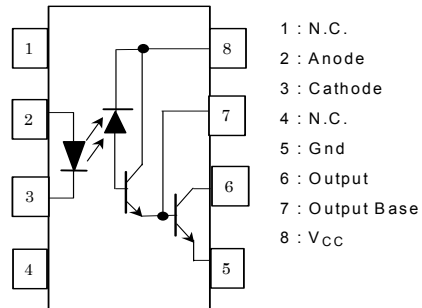

## Schematic

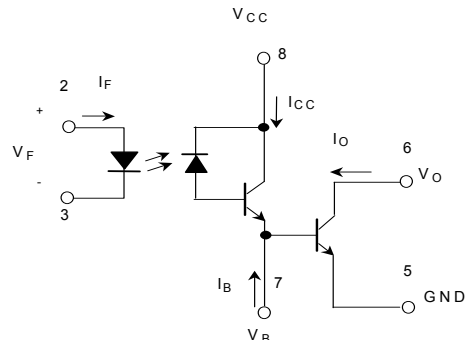

## Maximum Ratings (\*) (Ta = 0°C to + 70°C)

Characteristic		Symbol	Rating	Unit
LED	Forward current (Note 1)	$I_F$	20	mA
	Pulse forward current	$I_{FP}^{(*)}$	40	mA
	Total pulse forward current	$I_{FP}^{(**)}$	1	A
	Reverse voltage	$V_R$	5	V
	Diode power dissipation (Note 2)	$P_D$	35	mW
Detector	Output current (Note 3)	$I_O$	60	mA
	Emitter-base reverse voltage	$V_{EB}$	0.5	V
	Supply voltage	$V_{CC}^{(*)}$	-0.5 to 18	V
	Output voltage	$V_O^{(*)}$	-0.5 to 18	V
	Output power dissipation (Note 4)	$P_O$	100	mW
Operating temperature range		$T_{opr}$	0 to 70	°C
Storage temperature range		$T_{stg}$	-55 to 125	°C
Lead solder temperature (10s) <sup>(*)</sup>		$T_{sol}$	260	°C
Isolation voltage (1min., R.H.≤ 60%)		$BV_S^{(**)}$	2500	$V_{rms}$
			3540	$V_{dc}$

(\*) JEDEC registered data

(\*\*) Not registered JEDEC

(\*1) 50% duty cycle, 1ms pulse width

(\*2) Pulse width 1μs, 300pps

(\*3) 6N138... -0.5 to 7V

(\*4) 1.6mm below seating plane

**Electrical Characteristics**

**Over Recommended Temperature (Ta = 0°C to 70°C, unless otherwise noted)**

Characteristic		Symbol	Test Condition	Min.	(*5)Typ.	Max.	Unit
Current transfer ratio (Note 5, 6)	6N139	CTR(*)	I <sub>F</sub> =0.5mA, V <sub>O</sub> =0.4V V <sub>CC</sub> =4.5V	400	800	—	%
	6N138		I <sub>F</sub> =1.6mA, V <sub>O</sub> =0.4V V <sub>CC</sub> =4.5V	500	900	—	
Logic low output voltage (Note 6)	6N139	V <sub>OL</sub>	I <sub>F</sub> =1.6mA, I <sub>O</sub> =6.4mA V <sub>CC</sub> =4.5V	—	0.1	0.4	V
			I <sub>F</sub> =5mA, I <sub>O</sub> =15mA V <sub>CC</sub> =4.5V	—	0.1	0.4	
	I <sub>F</sub> =12mA, I <sub>O</sub> =24mA V <sub>CC</sub> =4.5V		—	0.2	0.4		
	6N138		I <sub>F</sub> =1.6mA, I <sub>O</sub> =4.8mA V <sub>CC</sub> =4.5V	—	0.1	0.4	
Logic high output current (Note 6)	6N139	I <sub>OH</sub> (*)	I <sub>F</sub> =0mA, V <sub>O</sub> =V <sub>CC</sub> =18V	—	0.05	100	μA
	6N138		I <sub>F</sub> =0mA, V <sub>O</sub> =V <sub>CC</sub> =7V	—	0.05	250	
Logic low supply current (Note 6)	I <sub>CCL</sub>	I <sub>F</sub> =1.6mA, V <sub>O</sub> =Open V <sub>CC</sub> =5V	—	0.2	—	mA	
Logic high supply current (Note 6)	I <sub>CCH</sub>	I <sub>F</sub> =0mA, V <sub>O</sub> =Open, V <sub>CC</sub> =5V	—	10	—	nA	
Input forward voltage	V <sub>F</sub> (*)	I <sub>F</sub> =1.6mA, Ta=25°C	—	1.65	1.7	V	
Input reverse breakdown voltage	BV <sub>R</sub> (*)	I <sub>R</sub> =10μA, Ta=25°C	5	—	—	V	
Temperature coefficient of forward voltage	ΔV <sub>F</sub> / ΔTa	I <sub>F</sub> =1.6mA	—	-1.9	—	mV / °C	
Input capacitance	C <sub>IN</sub>	f=1MHz, V <sub>F</sub> =0	—	60	—	pF	
Resistance (input-output)	R <sub>I-O</sub>	V <sub>I-O</sub> =500V R.H.≤ 60% (Note 7),	—	10 <sup>12</sup>	—	Ω	
Capacitance (input-output)	C <sub>I-O</sub>	f=1MHz (Note 7)	—	0.6	—	pF	

(\*\*) JEDEC registered data.

(\*5) All typicals at Ta=25°C and V<sub>CC</sub>=5V, unless otherwise noted.

## Switching Specifications (Ta=25°C, VCC=5V, unless otherwise specified)

Characteristic		Symbol	Test Circuit	Test Condition	Min.	Typ.	Max.	Unit
Propagation delay time to logic low at output (Note 6, 8)	6N139	$t_{pHL}^{(*)}$	1	$I_F=0.5mA, R_L=4.7k\Omega$	—	5	25	$\mu s$
				$I_F=12mA, R_L=270\Omega$	—	0.2	1	
	6N138			$I_F=1.6mA, R_L=2.2k\Omega$	—	1	10	
Propagation delay time to logic high at output (Note 6, 8)	6N139	$t_{pLH}^{(*)}$	1	$I_F=0.5mA, R_L=4.7k\Omega$	—	5	60	$\mu s$
				$I_F=12mA, R_L=270\Omega$	—	1	7	
	6N138			$I_F=1.6mA, R_L=2.2k\Omega$	—	4	35	
Common mode transient immunity at logic high level output (Note 9)		$CM_H$	2	$I_F=0mA, R_L=2.2k\Omega$ $V_{CM}=400V_{p-p}$	—	500	—	V / $\mu s$
Common mode transient immunity at logic low level output (Note 9)		$CM_L$	2	$I_F=1.6mA$ $R_L=2.2k\Omega$ $V_{CM}=400V_{p-p}$	—	-500	—	V / $\mu s$

(\*)JEDEC registered data.

(Note 1): Derate linearly above 50°C free-air temperature at a rate of 0.4mA / °C

(Note 2): Derate linearly above 50°C free-air temperature at a rate of 0.7mW / °C

(Note 3): Derate linearly above 25°C free-air temperature at a rate of 0.7mA / °C

(Note 4): Derate linearly above 25°C free-air temperature at a rate of 2.0mW / °C

(Note 5): DC CURRENT TRANSFER RATIO is defined as the ratio of output collector current,  $I_O$ , to the forward LED input current,  $I_F$ , times 100%.

(Note 6): Pin 7 open.

(Note 7): Device considered a two-terminal device: Pins 1, 2, 3, and 4 shorted together and Pins 5, 6, 7 and 8 shorted together.

(Note 8): Use of a resistor between pin 5 and 7 will decrease gain and delay time.

(Note 9): Common mode transient immunity in logic high level is the maximum tolerable (positive)  $dv_{CM} / dt$  on the leading edge of the common mode pulse,  $V_{CM}$ , to assure that the output will remain in a logic high state (i.e.,  $V_O > 2.0V$ ).

Common mode transient immunity in Logic Low level is the maximum tolerable (negative)  $dv_{CM} / dt$  on the trailing edge of the common mode pulse signal,  $V_{CM}$ , to assure that the output will remain in a logic low state (i.e.,  $V_O < 0.8V$ ).

**Test Circuit 1.**

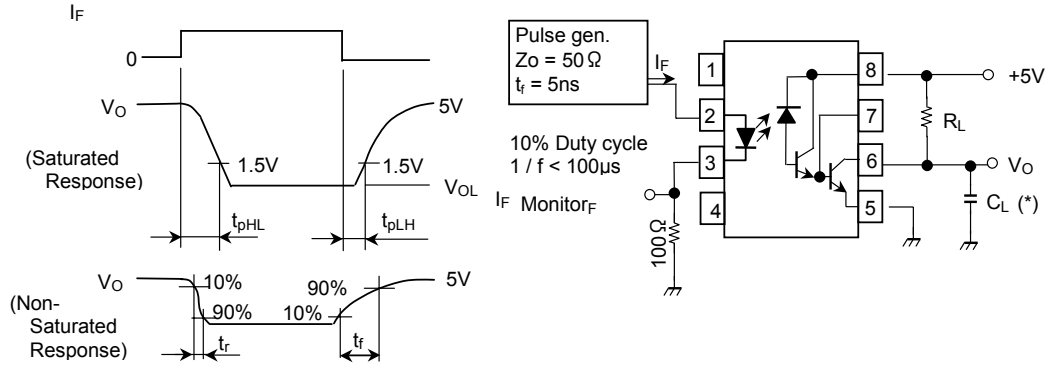

(\*) $C_L$  is approximately 15pF which includes probe and stray wiring capacitance.

**Test Circuit 2.**

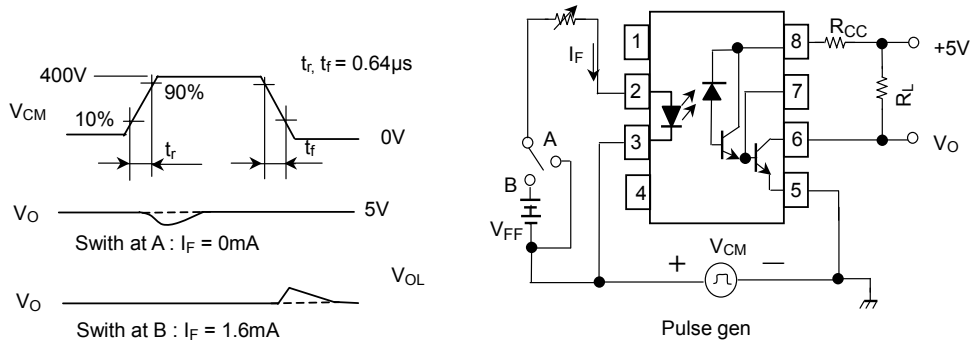

**RESTRICTIONS ON PRODUCT USE**

000707EBC

- TOSHIBA is continually working to improve the quality and reliability of its products. Nevertheless, semiconductor devices in general can malfunction or fail due to their inherent electrical sensitivity and vulnerability to physical stress. It is the responsibility of the buyer, when utilizing TOSHIBA products, to comply with the standards of safety in making a safe design for the entire system, and to avoid situations in which a malfunction or failure of such TOSHIBA products could cause loss of human life, bodily injury or damage to property.  
In developing your designs, please ensure that TOSHIBA products are used within specified operating ranges as set forth in the most recent TOSHIBA products specifications. Also, please keep in mind the precautions and conditions set forth in the "Handling Guide for Semiconductor Devices," or "TOSHIBA Semiconductor Reliability Handbook" etc..
- The TOSHIBA products listed in this document are intended for usage in general electronics applications (computer, personal equipment, office equipment, measuring equipment, industrial robotics, domestic appliances, etc.). These TOSHIBA products are neither intended nor warranted for usage in equipment that requires extraordinarily high quality and/or reliability or a malfunction or failure of which may cause loss of human life or bodily injury ("Unintended Usage"). Unintended Usage include atomic energy control instruments, airplane or spaceship instruments, transportation instruments, traffic signal instruments, combustion control instruments, medical instruments, all types of safety devices, etc.. Unintended Usage of TOSHIBA products listed in this document shall be made at the customer's own risk.
- Gallium arsenide (GaAs) is a substance used in the products described in this document. GaAs dust and fumes are toxic. Do not break, cut or pulverize the product, or use chemicals to dissolve them. When disposing of the products, follow the appropriate regulations. Do not dispose of the products with other industrial waste or with domestic garbage.
- The products described in this document are subject to the foreign exchange and foreign trade laws.
- The information contained herein is presented only as a guide for the applications of our products. No responsibility is assumed by TOSHIBA CORPORATION for any infringements of intellectual property or other rights of the third parties which may result from its use. No license is granted by implication or otherwise under any intellectual property or other rights of TOSHIBA CORPORATION or others.
- The information contained herein is subject to change without notice.

This datasheet has been download from:

[www.datasheetcatalog.com](http://www.datasheetcatalog.com)

Datasheets for electronics components.