

MAINS DIMMABLE 29 - 40W LED DRIVER

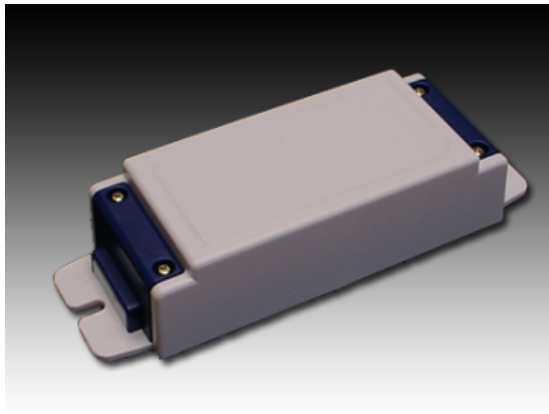

Main Features

- Leading and Trailing Edge dimmer compatible
- Selectable currents between 1A and 2.2A
- Compact design housing for easy installation
- Threefold PSU protection
- CE 61347-2-13 and 62384:2006 Approved
- Designed for high power LED Arrays

Product Overview

The market leading iDrive™ LED driver range now includes the iDrive™ MultiDIM™-HC. The MultiDIM™-HC driver is the first mains dimmable driver designed to work specifically with high power LED array technology, such as BRIDGELUX, ENFIS and Edison Opto.

The new MultiDIM™-HC range offers the latest phase control (trailing and leading edge) mains dimmable driver in various wattage output between 29W and 40W. The MultiDIM™-HC LED driver operates a single channel supplying a user selectable forward current between 1000 and 2200mA (see output table for details).

The driver enables a single LED array with a forward voltage between 8V-18V, 10V-18V and 12V-20V to be operated at various forward current options for maximum system flexibility.

The MultiDIM™-HC is built for resilience and offers threefold protection: Short circuit, overvoltage and open-circuit.

The MultiDIM™-HC is ideal for all types of LED lighting products that need to operate with conventional mains dimming circuits, including applications such as dichroic, halogen or CFL LED replacements and LED downlighters.

Protection

Overload Protection
Short-Circuit Protection
Open-Circuit Protection

Standards

EN 61347-2-13, EN55015:2006,
EN 61000-3-2, EN 61547,
EN 61047, EN 62384:2006

Approval

CE, FCC Class B

Electrical Specifications

Input

Input Voltage Range: 110V AC, 230V AC, 277V AC
Input Frequency: 50Hz, 60Hz
Consumption: See table below
Power Factor: >0.9 @ Full load
Efficiency: 75-85% Max
Connection: Mains AC loop-in, loop-out terminal block
Insulation Class: 1
Stand-by Power: <1W

Output

| Model Selection Table | | | | |
|-----------------------|------------|----------|-----------------------|--------------|
| Model | Input (ac) | Output V | Output A | Output W max |
| IDM029181 | 100 - 120V | 8 - 18V | 1.4 / 1.6 | 29W |
| IDM029182 | 200 - 240V | 8 - 18V | 1.4 / 1.6 | 29W |
| IDM029183 | 277V | 8 - 18V | 1.4 / 1.6 | 29W |
| IDM032181 | 100 - 120V | 8 - 18V | 1.2 / 1.4 / 1.6 / 1.8 | 32W |
| IDM032182 | 200 - 240V | 8 - 18V | 1.2 / 1.4 / 1.6 / 1.8 | 32W |
| IDM032183 | 277V | 8 - 18V | 1.2 / 1.4 / 1.6 / 1.8 | 32W |
| IDM040181 | 100 - 120V | 10 - 18V | 2.0/2.1/2.2 | 40W |
| IDM040182 | 200 - 240V | 10 - 18V | 2.0/2.1/2.2 | 40W |
| IDM040183 | 277V | 10 - 18V | 2.0/2.1/2.2 | 40W |
| IDM040201 | 100 - 120V | 12 - 20V | 1.0/1.25/1.5/2.0 | 40W |
| IDM040202 | 200 - 240V | 12 - 20V | 1.0/1.25/1.5/2.0 | 40W |
| IDM040203 | 277V | 12 - 20V | 1.0/1.25/1.5/2.0 | 40W |

Current Regulation: <5%
Current Tolerance: <10% on all outputs

Control Input

Dimming control: Auto Detection of either Trailing or Leading Edge Dimmer
Dimming Range: <10% to 100% of output load current

Mechanical

Mounting: Two 5mm holes for fixing
Construction: ABS Housing at IP 20 or IP64

Environmental

Operating Ambient Temperature: -20°C to + 50°C
Storage Ambient Temperature: -20°C to + 70°C
Relative Humidity: 80% MAX
Lifetime (failure after 50,000 hours): 5%
Lifetime (failures after 50,000 hours): 5%

Dimensions:

151 x 50.5 x 31 mm approx

Weight:

180 grams



www.istl.com



MAINS DIMMABLE 29 - 40W LED DRIVER

Typical iDrive MultiDIM-HC Performance

Results for model: IDM032181

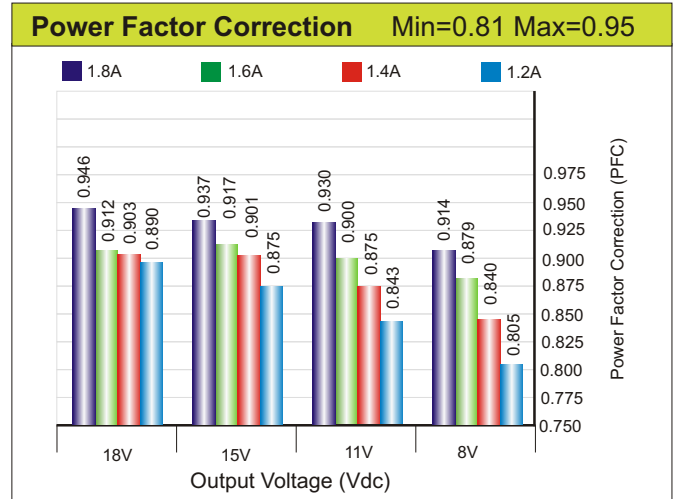
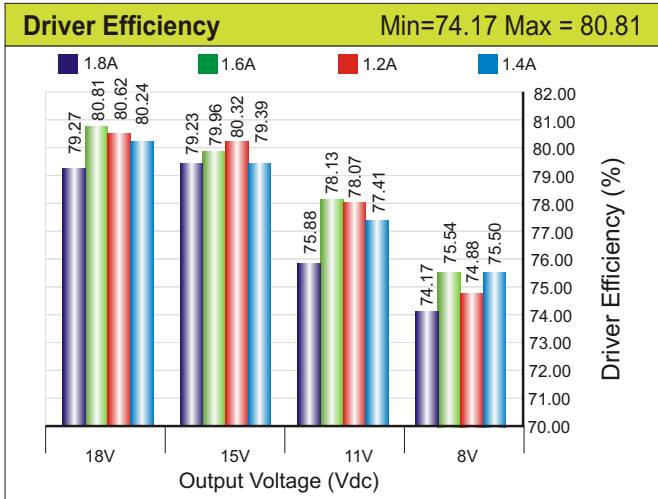

Wiring Diagram without Dimmer Switch for MultiDIM

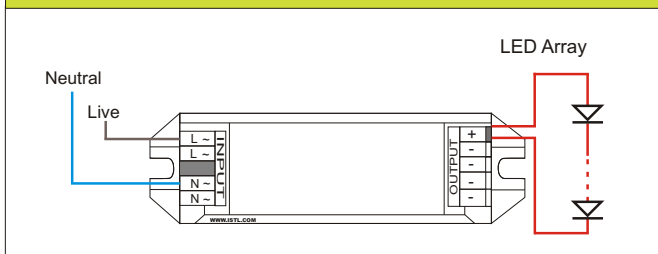

Wiring Diagram with Dimmer Switch for MultiDIM

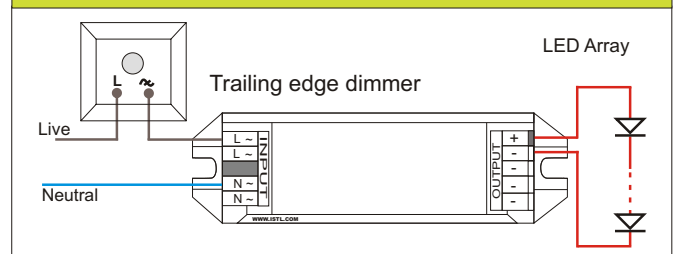

Dimensions

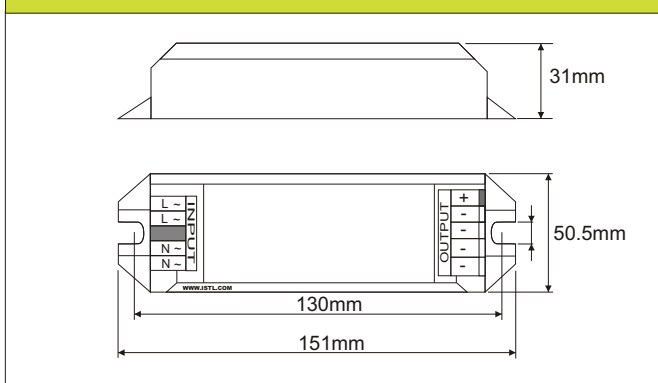

Wiring Diagram with Dimmer Switch for Multiple Drivers

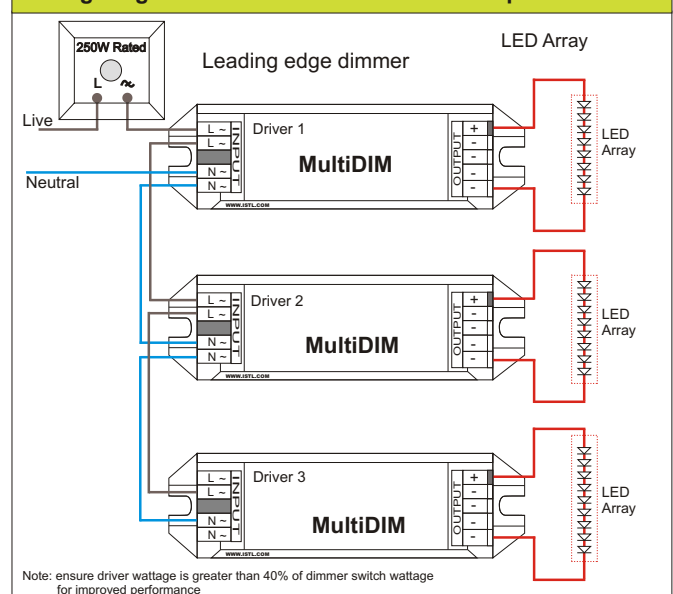

Leading Edge Dimming

Trailing Edge Dimming



Applications

Indoor, Outdoor, Spot, Decorative and downlight applications:

| | | | |
|---------|-------------|---------|---------------|
| Dining | Shops | Office | Architectural |
| Reading | Restaurants | Kitchen | Bathroom |
| Living | Museum | | |

www.istl.com



Preliminary Data V1.8