

NHD-2.4-240320SF-CTXI#-T1

TFT (Thin-Film Transistor) Liquid Crystal Display Module

NHD-	Newhaven Display
2.4-	2.4" diagonal
240320-	240 x 320 pixels (portrait mode)
SF-	Model
C-	Built-in Controller
T-	White LED backlight
X-	TFT- normally black
I-	Wide Temp (-20C ~ +70C), 12:00 view direction
#-	RoHS Compliant
T-	Touch Panel
1-	ILI9340 controller

Newhaven Display International, Inc.

2511 Technology Drive, Suite 101

Elgin IL, 60124

Ph: 847-844-8795

Fax: 847-844-8796

www.newhavendisplay.com

nhtech@newhavendisplay.com

nhsales@newhavendisplay.com

Document Revision History

Revision	Date	Description	Changed by
0	9/17/2010	Initial Release	MC

Functions and Features

- 240x320 pixels
- LED backlight
- 2.8V power supply
- 8-bit or 16-bit Parallel interface
- Hot-Bar Solder I/O connection
- Built-in ILI9340 controller
- 262K colors
- 4-wire resistive Touch Panel

Pin Description

Pin No.	Symbol	External Connection	Function Description
1	GND	Power Supply	GND
2	Y-	Touch Panel	Touch Panel – DOWN
3	X+	Touch Panel	Touch Panel – LEFT
4	Y+	Touch Panel	Touch Panel – UP
5	X-	Touch Panel	Touch Panel – RIGHT
6	LCD_ID	MPU/NC	LCD ID pin (No Connect)
7	VCC	Power Supply	Power Supply for LCD (2.8V)
8	IOVCC	Power Supply	Logic Signal Supply IOVCC= 1.65 ~ VCC
9	FMARK	MPU/NC	Used when writing RAM data in sync with frame (No connect)
10	/CS	MPU	Active low Chip Select (can tie to GND)
11	RS	MPU	Register Select: 0= write index register, 1= write data
12	/WR	MPU	Active low Write strobe
13	/RD	MPU	Active low Read strobe
14	DB0	MPU	Bi-directional data bus 8-bit: use DB15-DB8 16-bit: use DB15-DB0
15	DB1	MPU	
16	DB2	MPU	
17	DB3	MPU	
18	DB4	MPU	
19	DB5	MPU	
20	DB6	MPU	
21	DB7	MPU	
22	DB8	MPU	
23	DB9	MPU	
24	DB10	MPU	
25	DB11	MPU	
26	DB12	MPU	
27	DB13	MPU	
28	DB14	MPU	
29	DB15	MPU	
30	/RESET	MPU	Active LOW reset
31	IM0	MPU	IM0=0 : 16-bit i80 IM0=1: 8-bit i80
32	NC	NC	No Connect
33	GND	Power Supply	GND
34	LED-1	Power Supply	LED Cathode (GND)
35	LED-2	Power Supply	LED Cathode (GND)
36	LED-3	Power Supply	LED Cathode (GND)
37	LED-4	Power Supply	LED Cathode (GND)
38	LED-A	Power Supply	LED Anode (3.2V)
39	GND	Power Supply	GND

LCD connector: Hot-bar solder directly to PCB

Electrical Characteristics

Item	Symbol	Condition	Min.	Typ.	Max.	Unit
Operating Temperature Range	Top	Absolute Max	-10	25	+60	°C
Storage Temperature Range	Tst	Absolute Max	-20	25	+70	°C
Supply Voltage	VCC		2.5	2.8	3.3	V
I/O Supply Voltage	IOVCC		1.65	2.8	3.3	V
Supply Current	ICC	VCC=2.8V	-	7	9	mA
"H" Level input	Vih		0.8VCC	-	VCC	V
"L" Level input	Vil		0	-	0.2VCC	V
"H" Level output	Voh		0.8VCC	-	VCC	V
"L" Level output	Vol		0	-	0.2VCC	V
Backlight Supply Voltage	Vled		-	3.2	-	V
Backlight Supply Current	Iled	Vled=3.2V	-	20	-	mA
Brightness			-	350	-	cd/m2

Optical Characteristics

Item	Symbol	Condition	Min.	Typ.	Max.	Unit
Viewing Angle - Vertical	VA	Cr ≥ 10	-15		+35	°
Viewing Angle - Horizontal	VH	Cr ≥ 10	-45		+45	°
Contrast Ratio	Cr	3.2V, 25°C		250		
Response Time (rise)	Tr			10		ms
Response Time (fall)	Tr			20		ms

Touch Panel Characteristics

Item	Symbol	Condition	Min.	Typ.	Max.	Unit
Linearity			-	-	1.5	%
Insulation Resistance			10	-	-	MΩ
Operation Voltage			-	5	-	V
Response Time			-	-	10	ms
Transmittance			80	-	-	%
Operating Force			50	-	200	G
Touch Durability			1,000,000	-	-	Times
Handwriting Durability			100,000	-	-	Times
Hardness			3	-	-	H

Driver Information

Built-in ILI9340 controller.

See specification at http://www.newhavendisplay.com/app_notes/ILI9340.pdf

Table of Commands

8.1. Command List

Regulative Command Set													
Command Function	D/CX	RDX	WRX	D17-8	D7	D6	D5	D4	D3	D2	D1	D0	Hex
No Operation	0	1	↑	XX	0	0	0	0	0	0	0	0	00h
Software Reset	0	1	↑	XX	0	0	0	0	0	0	0	1	01h
Read Display Identification Information	0	1	↑	XX	0	0	0	0	0	1	0	0	04h
	1	↑	1	XX	X	X	X	X	X	X	X	X	XX
	1	↑	1	XX	ID1 [7:0]							XX	
	1	↑	1	XX	ID2 [7:0]							XX	
	1	↑	1	XX	ID3 [7:0]							XX	
Read Display Status	0	1	↑	XX	0	0	0	0	1	0	0	1	09h
	1	↑	1	XX	X	X	X	X	X	X	X	X	XX
	1	↑	1	XX	D [31:25]							X	00
	1	↑	1	XX	X	D [22:20]			D [19:16]				61
	1	↑	1	XX	X	X	X	X	X	D [10:8]			00
	1	↑	1	XX	D [7:5]			X	X	X	X	X	00
Read Display Power Mode	0	1	↑	XX	0	0	0	0	1	0	1	0	0Ah
	1	↑	1	XX	X	X	X	X	X	X	X	X	XX
	1	↑	1	XX	D [7:2]							0	0
Read Display MADCTL	0	1	↑	XX	0	0	0	0	1	0	1	1	0Bh
	1	↑	1	XX	X	X	X	X	X	X	X	X	XX
	1	↑	1	XX	D [7:2]							0	0
Read Display Pixel Format	0	1	↑	XX	0	0	0	0	1	1	0	0	0Ch
	1	↑	1	XX	X	X	X	X	X	X	X	X	XX
	1	↑	1	XX	RIM	DPI [2:0]		X	DBI [2:0]			06	
Read Display Image Format	0	1	↑	XX	0	0	0	0	1	1	0	1	0Dh
	1	↑	1	XX	X	X	X	X	X	X	X	X	XX
	1	↑	1	XX	X	X	X	X	X	D [2:0]		00	
Read Display Signal Mode	0	1	↑	XX	0	0	0	0	1	1	1	0	0Eh
	1	↑	1	XX	X	X	X	X	X	X	X	X	XX
	1	↑	1	XX	D [7:2]							0	0
Read Display Self-Diagnostic Result	0	1	↑	XX	0	0	0	0	1	1	1	1	0Fh
	1	↑	1	XX	X	X	X	X	X	X	X	X	XX
	1	↑	1	XX	D [7:6]			X	X	X	X	X	00
Enter Sleep Mode	0	1	↑	XX	0	0	0	1	0	0	0	0	10h
Sleep OUT	0	1	↑	XX	0	0	0	1	0	0	0	1	11h
Partial Mode ON	0	1	↑	XX	0	0	0	1	0	0	1	0	12h
Normal Display Mode ON	0	1	↑	XX	0	0	0	1	0	0	1	1	13h
Display Inversion OFF	0	1	↑	XX	0	0	1	0	0	0	0	0	20h
Display Inversion ON	0	1	↑	XX	0	0	1	0	0	0	0	1	21h
Gamma Set	0	1	↑	XX	0	0	1	0	0	1	1	0	26h
	1	1	↑	XX	GC [7:0]							01	
Display OFF	0	1	↑	XX	0	0	1	0	1	0	0	0	28h
Display ON	0	1	↑	XX	0	0	1	0	1	0	0	1	29h
Column Address Set	0	1	↑	XX	0	0	1	0	1	0	1	0	2Ah
	1	1	↑	XX	SC [15:8]							XX	
	1	1	↑	XX	SC [7:0]							XX	
	1	1	↑	XX	EC [15:8]							XX	
	1	1	↑	XX	EC [7:0]							XX	
Page Address Set	0	1	↑	XX	0	0	1	0	1	0	1	1	2Bh
	1	1	↑	XX	SP [15:8]							XX	
	1	1	↑	XX	SP [7:0]							XX	
	1	1	↑	XX	EP [15:8]							XX	
	1	1	↑	XX	EP [7:0]							XX	

Memory Write	0	1	↑	XX	0	0	1	0	1	1	0	0	2Ch
	1	1	↑		D [17:0]								XX
Color SET	0	1	↑	XX	0	0	1	0	1	1	0	1	2Dh
	1	↑	1	XX	R00 [5:0]								XX
	1	↑	1	XX	Rnn [5:0]								XX
	1	↑	1	XX	R31 [5:0]								XX
	1	↑	1	XX	G00 [5:0]								XX
	1	↑	1	XX	Gnn [5:0]								XX
	1	↑	1	XX	G63 [5:0]								XX
	1	↑	1	XX	B00 [5:0]								XX
	1	↑	1	XX	Bnn [5:0]								XX
	1	↑	1	XX	B31 [5:0]								XX
Memory Read	0	1	↑	XX	0	0	1	0	1	1	1	0	2Eh
	1	↑	1	XX	X	X	X	X	X	X	X	X	XX
	1	↑	1		D [17:0]								XX
Partial Area	0	1	↑	XX	0	0	1	1	0	0	0	0	30h
	1	1	↑	XX	SR [15:8]								00
	1	1	↑	XX	SR [7:0]								00
	1	1	↑	XX	ER [15:8]								01
	1	1	↑	XX	ER [7:0]								3F
Vertical Scrolling Definition	0	1	↑	XX	0	0	1	1	0	0	1	1	33h
	1	1	↑	XX	TFA [15:8]								00
	1	1	↑	XX	TFA [7:0]								00
	1	1	↑	XX	VSA [15:8]								01
	1	1	↑	XX	VSA [7:0]								40
	1	1	↑	XX	BFA [15:8]								00
1	1	↑	XX	BFA [7:0]								00	
Tearing Effect Line OFF	0	1	↑	XX	0	0	1	1	0	1	0	0	34h
Tearing Effect Line ON	0	1	↑	XX	0	0	1	1	0	1	0	1	35h
	1	1	↑	XX	X	X	X	X	X	X	X	M	00
Memory Access Control	0	1	↑	XX	0	0	1	1	0	1	1	0	36h
	1	1	↑	XX	MY	MX	MV	ML	BGR	MH	X	X	00
Vertical Scrolling Start Address	0	1	↑	XX	0	0	1	1	0	1	1	1	37h
	1	1	↑	XX	VSP [15:8]								00
	1	1	↑	XX	VSP [7:0]								00
Idle Mode OFF	0	1	↑	XX	0	0	1	1	1	0	0	0	38h
Idle Mode ON	0	1	↑	XX	0	0	1	1	1	0	0	1	39h
Pixel Format Set	0	1	↑	XX	0	0	1	1	1	0	1	0	3Ah
	1	1	↑	XX	X	DPI [2:0]			X	DBI [2:0]			66
Write Memory Continue	0	1	↑	XX	0	0	1	1	1	1	0	0	3Ch
	1	1	↑		D [17:0]								XX
Read Memory Continue	0	1	↑	XX	0	0	1	1	1	1	1	0	3Eh
	1	↑	1	XX	X	X	X	X	X	X	X	X	XX
	1	↑	1		D [17:0]								XX
Set Tear Scanline	0	1	↑	XX	0	1	0	0	0	1	0	0	44h
	1	1	↑	XX	X	X	X	X	X	X	X	STS [8]	00
	1	1	↑	XX	STS [7:0]								00
Get Scanline	0	1	↑	XX	0	1	0	0	0	1	0	1	45h
	1	↑	1	XX	X	X	X	X	X	X	X	X	XX
	1	↑	1	XX	X	X	X	X	X	X	GTS [9:8]		00
	1	↑	1	XX	GTS [7:0]								00
Write Display Brightness	0	1	↑	XX	0	1	0	1	0	0	0	1	51h
	1	1	↑	XX	DBV [7:0]								00

Read Display Brightness	0	1	↑	XX	0	1	0	1	0	0	1	0	52h
	1	↑	1	XX	X	X	X	X	X	X	X	X	XX
	1	↑	1	XX	DBV [7:0]								00
Write CTRL Display	0	1	↑	XX	0	1	0	1	0	0	1	1	53h
	1	1	↑	XX	X	X	BCTRL	X	DD	BL	X	X	00
Read CTRL Display	0	1	↑	XX	0	1	0	1	0	1	0	0	54h
	1	↑	1	XX	X	X	X	X	X	X	X	X	XX
	1	↑	1	XX	X	X	BCTRL	X	DD	BL	X	X	00
Write Content Adaptive Brightness Control	0	1	↑	XX	0	1	0	1	0	1	0	1	55h
	1	1	↑	XX	X	X	X	X	X	X	C [1:0]		00
Read Content Adaptive Brightness Control	0	1	↑	XX	0	1	0	1	0	1	1	0	56h
	1	↑	1	XX	X	X	X	X	X	X	X	X	XX
	1	↑	1	XX	X	X	X	X	X	X	C [1:0]		00
Write CABC Minimum Brightness	0	1	↑	XX	0	1	0	1	1	1	1	0	5Eh
	1	1	↑	XX	CMB [7:0]								00
Read CABC Minimum Brightness	0	1	↑	XX	0	1	0	1	0	1	1	1	5Fh
	1	↑	1	XX	X	X	X	X	X	X	X	X	XX
	1	↑	1	XX	CMB [7:0]								00
Read ID1	0	1	↑	XX	1	1	0	1	1	0	1	0	DAh
	1	↑	1	XX	X	X	X	X	X	X	X	X	XX
	1	↑	1	XX	Module's Manufacture [7:0]								XX
Read ID2	0	1	↑	XX	1	1	0	1	1	0	1	1	DBh
	1	↑	1	XX	X	X	X	X	X	X	X	X	XX
	1	↑	1	XX	LCD Module / Driver Version [7:0]								XX
Read ID3	0	1	↑	XX	1	1	0	1	1	1	0	0	DC h
	1	↑	1	XX	X	X	X	X	X	X	X	X	XX
	1	↑	1	XX	LCD Module / Driver ID [7:0]								XX

Extended Command Set														
Command Function	D/CX	RDX	WRX	D17-8	D7	D6	D5	D4	D3	D2	D1	D0	Hex	
RGB Interface Signal Control	0	1	↑	XX	1	0	1	1	0	0	0	0	B0h	
	1	1	↑	XX	ByPass_MODE	RCM [1:0]		X	VSPL	HSPL	DPL	EPL	40	
Frame Control (In Normal Mode)	0	1	↑	XX	1	0	1	1	0	0	0	1	B1h	
	1	1	↑	XX	X	X	X	X	X	X	DIVA [1:0]		00	
	1	1	↑	XX	X	X	X	RTNA [4:0]				1B		
Frame Control (In Idle Mode)	0	1	↑	XX	1	0	1	1	0	0	1	0	B2h	
	1	1	↑	XX	X	X	X	X	X	X	DIVB [1:0]		00	
	1	1	↑	XX	X	X	X	RTNB [4:0]				1B		
Frame Control (In Partial Mode)	0	1	↑	XX	1	0	1	1	0	0	1	1	B3h	
	1	1	↑	XX	X	X	X	X	X	X	DIVC [1:0]		00	
	1	1	↑	XX	X	X	X	RTNC [4:0]				1B		
Display Inversion Control	0	1	↑	XX	1	0	1	1	0	1	0	0	B4h	
	1	1	↑	XX	X	X	X	X	X	NLA	NLB	NLC	02	
	1	1	↑	XX	X	X	NW [5:0]					00		
Blanking Porch Control	0	1	↑	XX	1	0	1	1	0	1	0	1	B5h	
	1	1	↑	XX	0	VFP [6:0]						02		
	1	1	↑	XX	0	VBP [6:0]						02		
	1	1	↑	XX	0	0	0	HFP [4:0]				0A		
	1	1	↑	XX	0	0	0	HBP [4:0]				14		
Display Function Control	0	1	↑	XX	1	0	1	1	0	1	1	0	B6h	
	1	1	↑	XX	X	X	X	X	PTG [1:0]		PT [1:0]		0A	
	1	1	↑	XX	REV	GS	SS	SM	ISC [3:0]				82	
	1	1	↑	XX	X	X	NL [5:0]					27		
	1	1	↑	XX	X	X	PCDIV [5:0]					XX		
Entry Mode Set	0	1	↑	XX	1	0	1	1	0	1	1	1	B7h	
	1	1	↑	XX	X	X	X	X	DSTB	GON	DTE	GAS	07	
Backlight Control 1	0	1	↑	XX	1	0	1	1	1	0	0	0	B8h	
	1	1	↑	XX	X	X	X	X	X	X	X	X	XX	
	1	1	↑	XX	X	X	X	X	TH_UI [3:0]				04	
Backlight Control 2	0	1	↑	XX	1	0	1	1	1	0	0	1	B9h	
	1	1	↑	XX	X	X	X	X	X	X	X	X	XX	
	1	1	↑	XX	TH_MV [3:0]				TH_ST [3:0]				B8	
Backlight Control 3	0	1	↑	XX	1	0	1	1	1	0	1	0	BAh	
	1	1	↑	XX	X	X	X	X	X	X	X	X	XX	
	1	1	↑	XX	X	X	X	X	DTH_UI [3:0]				04	
Backlight Control 4	0	1	↑	XX	1	0	1	1	1	0	1	1	BBh	
	1	1	↑	XX	X	X	X	X	X	X	X	X	XX	
	1	1	↑	XX	DTH_MV [3:0]				DTH_ST [3:0]				C9	
Backlight Control 5	0	1	↑	XX	1	0	1	1	1	1	0	0	BCh	
	1	1	↑	XX	X	X	X	X	X	X	X	X	XX	
	1	1	↑	XX	DIM2 [3:0]				X	DIM1 [2:0]			44	
Backlight Control 7	0	1	↑	XX	1	0	1	1	1	1	1	0	BEh	
	1	1	↑	XX	PWM_DIV [7:0]									
Backlight Control 8	0	1	↑	XX	1	0	1	1	1	1	1	1	BFh	
	1	1	↑	XX	X	X	X	X	X	LEDONR	LEDONPOL	LEDPWMOPL	00	
Power Control 1	0	1	↑	XX	1	1	0	0	0	0	0	0	C0h	
	1	1	↑	XX	X	X	VRH [5:0]					26		
	1	1	↑	XX	X	X	X	X	VC [3:0]				00	

Power Control 2	0	1	↑	XX	1	1	0	0	0	0	0	1	C1h
	1	1	↑	XX	X	X	X	X	BT [3:0]				00
Power Control 3 (For Normal Mode)	0	1	↑	XX	1	1	0	0	0	0	1	0	C2h
	1	1	↑	XX	1	DCA1 [2:0]			0	DCA0 [2:0]			B2
Power Control 4 (For Idle Mode)	0	1	↑	XX	1	1	0	0	0	0	1	1	C3h
	1	1	↑	XX	1	DCB1 [2:0]			0	DCB0 [2:0]			B2
Power Control 5 (For Partial Mode)	0	1	↑	XX	1	1	0	0	0	1	0	0	C4h
	1	1	↑	XX	1	DCC1 [2:0]			0	DCC0 [2:0]			B2
VCOM Control 1	0	1	↑	XX	1	1	0	0	0	1	0	1	C5h
	1	1	↑	XX	X	VMH [6:0]						31	
	1	1	↑	XX	X	VML [6:0]						3C	
VCOM Control 2	0	1	↑	XX	1	1	0	0	0	1	1	1	C7h
	1	1	↑	XX	nVM	VMF [6:0]						C0	
NV Memory Write	0	1	↑	XX	1	1	0	1	0	0	0	0	D0h
	1	1	↑	XX	X	X	X	X	X	PGM_ADR [2:0]			00
	1	1	↑	XX	PGM_DATA [7:0]							XX	
NV Memory Protection Key	0	1	↑	XX	1	1	0	1	0	0	0	1	D1h
	1	1	↑	XX	KEY [23:16]								55
	1	1	↑	XX	KEY [15:8]								AA
	1	1	↑	XX	KEY [7:0]								66
NV Memory Status Read	0	1	↑	XX	1	1	0	1	0	0	1	0	D2h
	1	↑	1	XX	X	X	X	X	X	X	X	X	XX
	1	↑	1	XX	X	ID2_CNT [2:0]			X	ID1_CNT [2:0]			XX
	1	↑	1	XX	BUSY	VMF_CNT [2:0]			X	ID3_CNT [2:0]			XX
Read ID4	0	↑	1	XX	1	1	0	1	0	0	1	1	D3h
	1	↑	1	XX	X	X	X	X	X	X	X	X	XX
	1	↑	1	XX	0	0	0	0	0	0	0	0	00
	1	↑	1	XX	X	X	X	X	X	X	X	X	XX
	1	↑	1	XX	0	1	0	0	0	0	0	0	40
Positive Gamma Correction	0	1	↑	XX	1	1	1	0	0	0	0	0	E0h
	1	1	↑	XX	X	X	X	X	VP0 [3:0]			0F	
	1	1	↑	XX	X	X	VP1 [5:0]					22	
	1	1	↑	XX	X	X	VP2 [5:0]					1F	
	1	1	↑	XX	X	X	X	X	VP4 [3:0]			0A	
	1	1	↑	XX	X	X	X	VP6 [4:0]				0E	
	1	1	↑	XX	X	X	X	X	VP13 [3:0]			06	
	1	1	↑	XX	X	VP20 [6:0]						4D	
	1	1	↑	XX	VP36 [3:0]				VP27 [3:0]				76
	1	1	↑	XX	X	VP43 [6:0]						3B	
	1	1	↑	XX	X	X	X	X	VP50 [3:0]			03	
	1	1	↑	XX	X	X	X	VP57 [4:0]				0E	
	1	1	↑	XX	X	X	X	X	VP59 [3:0]			04	
	1	1	↑	XX	X	X	VP61 [5:0]					13	
	1	1	↑	XX	X	X	VP62 [5:0]					0E	
	1	1	↑	XX	X	X	X	X	VP63 [3:0]			0C	

Negative Gamma CorrectionE	0	1	↑	XX	1	1	1	0	0	0	0	1	E1h
	1	1	↑	XX	X	X	X	X	VN0 [4:0]				0C
	1	1	↑	XX	X	X	VN1 [5:0]					23	
	1	1	↑	XX	X	X	VN2 [5:0]					26	
	1	1	↑	XX	X	X	X	X	VN4 [3:0]				04
	1	1	↑	XX	X	X	X	VN6 [4:0]				10	
	1	1	↑	XX	X	X	X	X	VN13 [3:0]				04
	1	1	↑	XX	X	VN20 [6:0]						39	
	1	1	↑	XX	VN36 [3:0]			VN27 [3:0]				24	
	1	1	↑	XX	X	VN43 [6:0]						4B	
	1	1	↑	XX	X	X	X	X	VN50 [3:0]				03
	1	1	↑	XX	X	X	X	VN57 [4:0]				0B	
	1	1	↑	XX	X	X	X	X	VN59 [3:0]				0B
	1	1	↑	XX	X	X	VN61 [5:0]					33	
	1	1	↑	XX	X	X	VN62 [5:0]					37	
1	1	↑	XX	X	X	X	X	VN63 [4:0]				0F	
Digital Gamma Control 1	0	1	↑	XX	1	1	1	0	0	0	1	0	E2h
1 st Parameter	1	1	↑	XX	RCA0 [3:0]				BCA0 [3:0]				XX
:	1	1	↑	XX	RCAx [3:0]				BCAx [3:0]				XX
16 th Parameter	1	1	↑	XX	RCA15 [3:0]				BCA15 [3:0]				XX
Digital Gamma Control 2	0	1	↑	XX	1	1	1	0	0	0	1	1	E3h
1 st Parameter	1	1	↑	XX	RFA0 [3:0]				BFA0 [3:0]				XX
:	1	1	↑	XX	RFAx [3:0]				BFAx [3:0]				XX
64 th Parameter	1	1	↑	XX	RFA63 [3:0]				BFA63 [3:0]				XX
Interface Control	0	1	↑	XX	1	1	1	1	0	1	1	0	F6h
	1	1	↑	XX	MY_EOR	MX_EOR	MV_EOR	X	BGR_EOR	X	X	WEMODE	01
	1	1	↑	XX	X	X	EPF [1:0]		X	X	MDT [1:0]		00
	1	1	↑	XX	X	X	ENDIAN	X	DM [1:0]		RM	RIM	00

Timing Characteristics

19.3. AC Characteristics

19.3.1. Display Parallel 18/16/9/8-bit Interface Timing Characteristics (8080- I system)

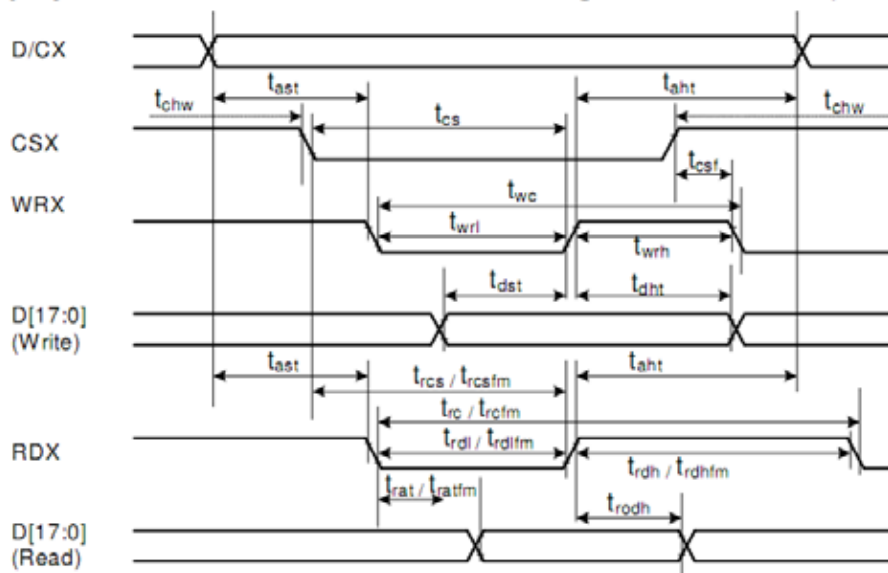

Signal	Symbol	Parameter	min	max	Unit	Description
DCX	tast	Address setup time	0	-	ns	
	taht	Address hold time (Write/Read)	10	-	ns	
CSX	tchwh	CSX "H" pulse width	0	-	ns	
	tcs	Chip Select setup time (Write)	15	-	ns	
	trcs	Chip Select setup time (Read ID)	45	-	ns	
	trcsfm	Chip Select setup time (Read FM)	355	-	ns	
	tcsf	Chip Select Wait time (Write/Read)	10	-	ns	
WRX	twc	Write cycle	66	-	ns	
	twrh	Write Control pulse H duration	33	-	ns	
	twrl	Write Control pulse L duration	33	-	ns	
RDX (FM)	trcfm	Read Cycle (FM)	450	-	ns	
	trdhfm	Read Control H duration (FM)	90	-	ns	
	trdlfm	Read Control L duration (FM)	355	-	ns	
RDX (ID)	trc	Read cycle (ID)	160	-	ns	
	trdh	Read Control pulse H duration	90	-	ns	
	trdl	Read Control pulse L duration	45	-	ns	
D[17:0], D[15:0], D[8:0], D[7:0]	tdst	Write data setup time	10	-	ns	For maximum CL=30pF For minimum CL=8pF
	tdht	Write data hold time	10	-	ns	
	trat	Read access time	-	60	ns	
	tratfm	Read access time	-	340	ns	
	trod	Read output disable time	20	80	ns	

Note: $T_a = -30$ to 70 °C, $V_{DDI} = 1.65V$ to $3.3V$, $V_{CI} = 2.5V$ to $3.3V$, $V_{SS} = 0V$

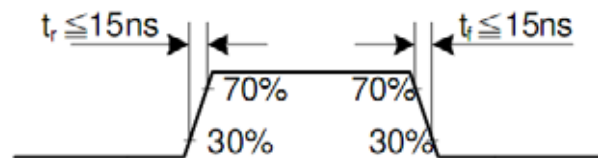

CSX timings :

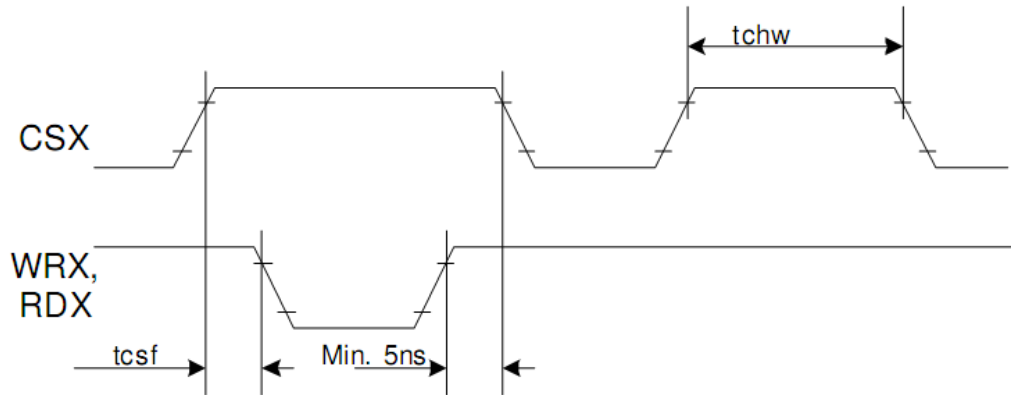

Note: Logic high and low levels are specified as 30% and 70% of VDDI for Input signals.

Write to read or read to write timings:

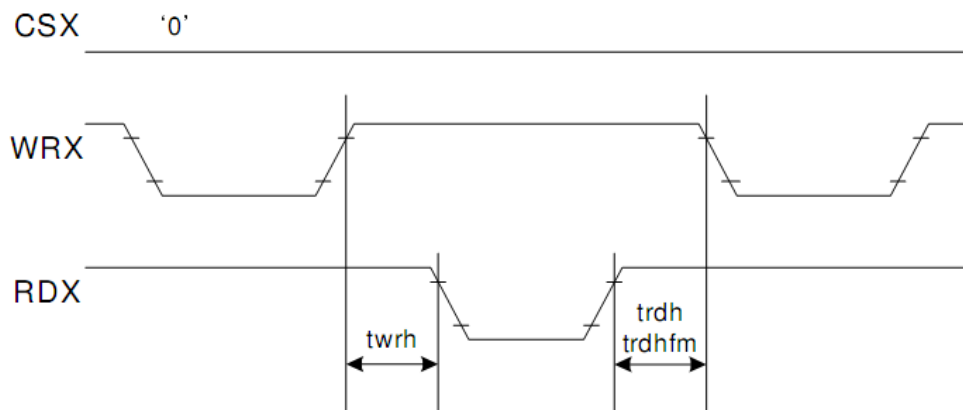

Note: Logic high and low levels are specified as 30% and 70% of VDDI for Input signals.

Quality Information

Test Item	Content of Test	Test Condition	Note
High Temperature storage	Endurance test applying the high storage temperature for a long time.	+70°C , 96hrs	2
Low Temperature storage	Endurance test applying the low storage temperature for a long time.	-20°C , 96hrs	1,2
High Temperature Operation	Endurance test applying the electric stress (voltage & current) and the high thermal stress for a long time.	+60°C , 96hrs	2
Low Temperature Operation	Endurance test applying the electric stress (voltage & current) and the low thermal stress for a long time.	-10°C , 96hrs	1,2
High Temperature / Humidity Operation	Endurance test applying the electric stress (voltage & current) and the high thermal with high humidity stress for a long time.	+50°C , 90% RH , 96hrs	1,2
Thermal Shock resistance	Endurance test applying the electric stress (voltage & current) during a cycle of low and high thermal stress.	-10°C,30min -> 25°C,5min -> 60°C,30min = 1 cycle 100 cycles	
Vibration test	Endurance test applying vibration to simulate transportation and use.	10-150Hz , 15mm amplitude. 60 sec in each of 3 directions X,Y,Z For 15 minutes	3
Static electricity test	Endurance test applying electric static discharge.	VS=4KV, RS=330kΩ, CS=150pF Five times	

Note 1: No condensation to be observed.

Note 2: Conducted after 4 hours of storage at 25°C, 0%RH.

Note 3: Test performed on product itself, not inside a container.

Precautions for using LCDs/LCMs

See Precautions at www.newhavendisplay.com/specs/precautions.pdf

Warranty Information

See Terms & Conditions at http://www.newhavendisplay.com/index.php?main_page=terms