

FEATURES

- Low Cost**
- Excellent Video Performance**
 - 55 MHz 0.1 dB Bandwidth (Gain = +2)
 - 0.01% and 0.05° Differential Gain and Phase Errors
- High Speed**
 - 130 MHz Bandwidth (3 dB, G = +2)
 - 100 MHz Bandwidth (3 dB, G+ = -1)
 - 500 V/ μ s Slew Rate
 - 80 ns Settling Time to 0.01% ($V_O = 10$ V Step)
- High Output Drive Capability**
 - 50 mA Minimum Output Current
 - Ideal for Driving Back Terminated Cables
- Flexible Power Supply**
 - Specified for Single (+5 V) and Dual (± 5 V to ± 15 V) Power Supplies
 - Low Power: 7.5 mA Max Supply Current
- Available in 8-Lead SOIC and 8-Lead PDIP**

GENERAL DESCRIPTION

The AD818 is a low cost video op amp optimized for use in video applications that require gains equal to or greater than +2 or -1. The AD818's low differential gain and phase errors, single supply functionality, low power, and high output drive make it ideal for cable driving applications such as video cameras and professional video equipment.

With video specs like 0.1 dB flatness to 55 MHz and low differential gain and phase errors of 0.01% and 0.05°, along with 50 mA of output current, the AD818 is an excellent choice for

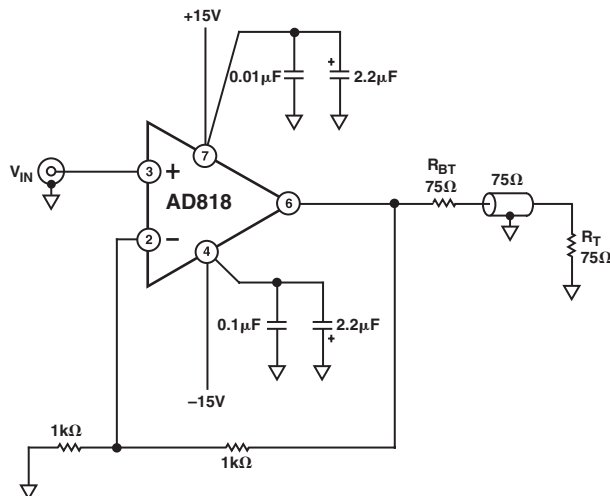
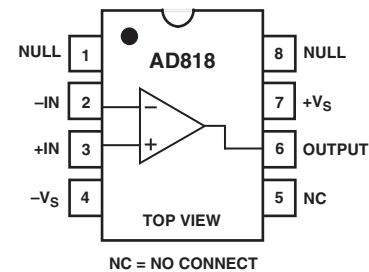

Figure 1. Video Line Driver

CONNECTION DIAGRAM

8-Lead Plastic Mini-DIP (N) and SOIC (R) Packages



any video application. The 130 MHz 3 dB bandwidth (G = +2) and 500 V/ μ s slew rate make the AD818 useful in many high speed applications including video monitors, CATV, color copiers, image scanners, and fax machines.

The AD818 is fully specified for operation with a single +5 V power supply and with dual supplies from ± 5 V to ± 15 V. This power supply flexibility, coupled with a very low supply current of 7.5 mA and excellent ac characteristics under all power supply conditions, make the AD818 the ideal choice for many demanding yet power sensitive applications.

The AD818 is a voltage feedback op amp and excels as a gain stage in high speed and video systems (gain ≥ 2 , or gain ≤ -1). It achieves a settling time of 45 ns to 0.1%, with a low input offset voltage of 2 mV max.

The AD818 is available in low cost, small 8-lead PDIP and SOIC packages.

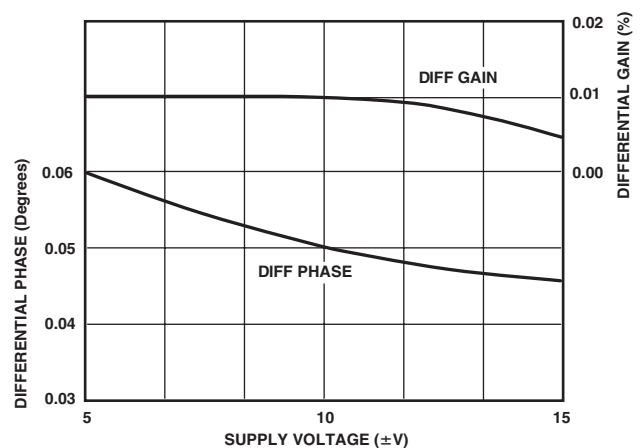

Figure 2. Differential Gain and Phase vs. Supply

Information furnished by Analog Devices is believed to be accurate and reliable. However, no responsibility is assumed by Analog Devices for its use, nor for any infringements of patents or other rights of third parties that may result from its use. No license is granted by implication or otherwise under any patent or patent rights of Analog Devices. Trademarks and registered trademarks are the property of their respective companies.

AD818—SPECIFICATIONS

(@ $T_A = 25^\circ\text{C}$, unless otherwise noted.)

Parameter	Conditions	V_S	AD818A			Unit
			Min	Typ	Max	
DYNAMIC PERFORMANCE						
-3 dB Bandwidth	Gain = +2	$\pm 5\text{ V}$	70	95		MHz
		$\pm 15\text{ V}$	100	130		MHz
		0 V, +5 V	40	55		MHz
Bandwidth for 0.1 dB Flatness	Gain = -1	$\pm 5\text{ V}$	50	70		MHz
		$\pm 15\text{ V}$	70	100		MHz
		0 V, +5 V	30	50		MHz
	Gain = +2 $C_C = 2\text{ pF}$	$\pm 5\text{ V}$	20	43		MHz
		$\pm 15\text{ V}$	40	55		MHz
		0 V, +5 V	10	18		MHz
Full Power Bandwidth*	Gain = -1 $C_C = 2\text{ pF}$	$\pm 5\text{ V}$	18	34		MHz
		$\pm 15\text{ V}$	40	72		MHz
		0 V, +5 V	10	19		MHz
	$V_{OUT} = 5\text{ V p-p}$ $R_{LOAD} = 500\ \Omega$ $V_{OUT} = 20\text{ V p-p}$ $R_{LOAD} = 1\text{ k}\Omega$	$\pm 5\text{ V}$		25.5		MHz
		$\pm 15\text{ V}$		8.0		MHz
		$\pm 5\text{ V}$	350	400		V/ μs
Slew Rate	$R_{LOAD} = 1\text{ k}\Omega$ Gain = -1	$\pm 15\text{ V}$	450	500		V/ μs
		0 V, +5 V	250	300		V/ μs
		$\pm 5\text{ V}$		45		ns
Settling Time to 0.1%	-2.5 V to +2.5 V 0 V-10 V Step, $A_V = -1$	$\pm 15\text{ V}$		45		ns
Settling Time to 0.01%	-2.5 V to +2.5 V 0 V-10 V Step, $A_V = -1$	$\pm 15\text{ V}$		80		ns
		$\pm 5\text{ V}$		80		ns
		$\pm 15\text{ V}$		63		dB
Total Harmonic Distortion	$F_C = 1\text{ MHz}$	$\pm 15\text{ V}$		0.005	0.01	%
Differential Gain Error ($R_L = 150\ \Omega$)	NTSC Gain = +2	$\pm 15\text{ V}$		0.01	0.02	%
		$\pm 5\text{ V}$		0.08		%
		0 V, +5 V		0.045	0.09	Degrees
Differential Phase Error ($R_L = 150\ \Omega$)	NTSC Gain = +2	$\pm 15\text{ V}$		0.06	0.09	Degrees
		$\pm 5\text{ V}$		0.1		Degrees
		0 V, +5 V		10		pF
Cap Load Drive						
INPUT OFFSET VOLTAGE						
Offset Drift	T_{MIN} to T_{MAX}	$\pm 5\text{ V to } \pm 15\text{ V}$		0.5	2	mV
					3	mV
				10		$\mu\text{V}/^\circ\text{C}$
INPUT BIAS CURRENT						
	T_{MIN} T_{MAX}	$\pm 5\text{ V, } \pm 15\text{ V}$		3.3	6.6	μA
					10	μA
					4.4	μA
INPUT OFFSET CURRENT						
Offset Current Drift	T_{MIN} to T_{MAX}	$\pm 5\text{ V, } \pm 15\text{ V}$		25	300	nA
					500	nA
				0.3		$\text{nA}/^\circ\text{C}$
OPEN-LOOP GAIN						
	$V_{OUT} = \pm 2.5\text{ V}$ $R_{LOAD} = 500\ \Omega$ T_{MIN} to T_{MAX} $R_{LOAD} = 150\ \Omega$	$\pm 5\text{ V}$	3	5		V/mV
			2			V/mV
			2	4		V/mV
	$V_{OUT} = \pm 10\text{ V}$ $R_{LOAD} = 1\text{ k}\Omega$ T_{MIN} to T_{MAX}	$\pm 15\text{ V}$	6	9		V/mV
			3			V/mV
	$V_{OUT} = \pm 7.5\text{ V}$ $R_{LOAD} = 150\ \Omega$ (50 mA Output)	$\pm 15\text{ V}$	3	5		V/mV
COMMON-MODE REJECTION						
	$V_{CM} = \pm 2.5\text{ V}$ $V_{CM} = \pm 12\text{ V}$ T_{MIN} to T_{MAX}	$\pm 5\text{ V}$	82	100		dB
		$\pm 15\text{ V}$	86	120		dB
		$\pm 15\text{ V}$	84	100		dB

Parameter	Conditions	V _S	AD818A			Unit
			Min	Typ	Max	
POWER SUPPLY REJECTION	V _S = ±5 V to ±15 V T _{MIN} to T _{MAX}		80	90		dB
			80			dB
INPUT VOLTAGE NOISE	f = 10 kHz	±5 V, ±15 V		10		nV/√Hz
INPUT CURRENT NOISE	f = 10 kHz	±5 V, ±15 V		1.5		pA/√Hz
INPUT COMMON-MODE VOLTAGE RANGE		±5 V	+3.8	+4.3		V
			-2.7	-3.4		V
			+13	+14.3		V
			-12	-13.4		V
			+3.8	+4.3		V
OUTPUT VOLTAGE SWING	R _{LOAD} = 500 Ω R _{LOAD} = 150 Ω R _{LOAD} = 1 kΩ R _{LOAD} = 500 Ω R _{LOAD} = 500 Ω	±5 V	3.3	3.8		±V
			3.2	3.6		±V
			13.3	13.7		±V
			12.8	13.4		±V
			1.5, 3.5			V
Output Current		±15 V	50			mA
			50			mA
			50			mA
Short-Circuit Current		0 V, +5 V	30			mA
				90		mA
INPUT RESISTANCE				300		kΩ
INPUT CAPACITANCE				1.5		pF
OUTPUT RESISTANCE	Open Loop			8		Ω
POWER SUPPLY Operating Range	Dual Supply Single Supply		±2.5		±18	V
			+5		+36	V
Quiescent Current	T _{MIN} to T _{MAX}	±5 V		7.0	7.5	mA
			±5 V		7.5	mA
			±15 V		7.5	mA
			±15 V	7.0	7.5	mA

*Full power bandwidth = slew rate/(2π V_{PEAK}).

Specifications subject to change without notice.

AD818

ABSOLUTE MAXIMUM RATINGS¹

Supply Voltage	±18 V
Internal Power Dissipation ²	
Plastic (N)	See Derating Curves
Small Outline (R)	See Derating Curves
Input Voltage (Common Mode)	±V _S
Differential Input Voltage	±6 V
Output Short-Circuit Duration	See Derating Curves
Storage Temperature Range (N, R)	-65°C to +125°C
Operating Temperature Range	-40°C to +85°C
Lead Temperature Range (Soldering 10 sec)	300°C

NOTES

¹Stresses above those listed under Absolute Maximum Ratings may cause permanent damage to the device. This is a stress rating only; functional operation of the device at these or any other conditions above those indicated in the operational section of this specification is not implied. Exposure to absolute maximum rating conditions for extended periods may affect device reliability.

²Specification is for device in free air: 8-lead plastic package, $\theta_{JA} = 90^\circ\text{C/W}$; 8-lead SOIC package, $\theta_{JA} = 155^\circ\text{C/W}$.

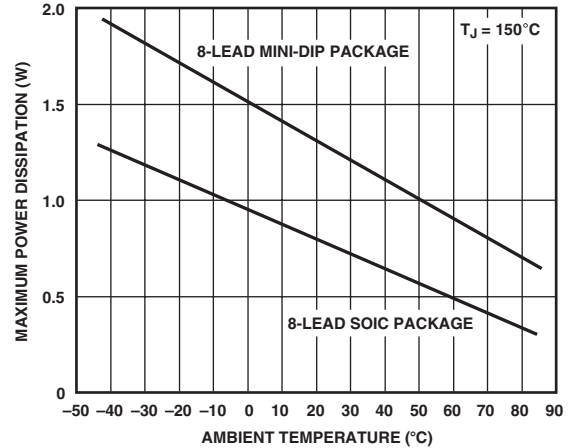

Figure 3. Maximum Power Dissipation vs. Temperature for Different Package Types

ORDERING GUIDE

Model	Temperature Range	Package Description	Package Option
AD818AN	-40°C to +85°C	8-Lead Plastic PDIP	N-8
AD818AR	-40°C to +85°C	8-Lead Plastic SOIC	R-8
AD818AR-REEL	-40°C to +85°C	13" Tape and Reel	R-8
AD818AR-REEL7	-40°C to +85°C	7" Tape and Reel	R-8

CAUTION

ESD (electrostatic discharge) sensitive device. Electrostatic charges as high as 4000 V readily accumulate on the human body and test equipment and can discharge without detection. Although the AD818 features proprietary ESD protection circuitry, permanent damage may occur on devices subjected to high energy electrostatic discharges. Therefore, proper ESD precautions are recommended to avoid performance degradation or loss of functionality.



METALLIZATION PHOTOGRAPH

Dimensions shown in inches and (mm)

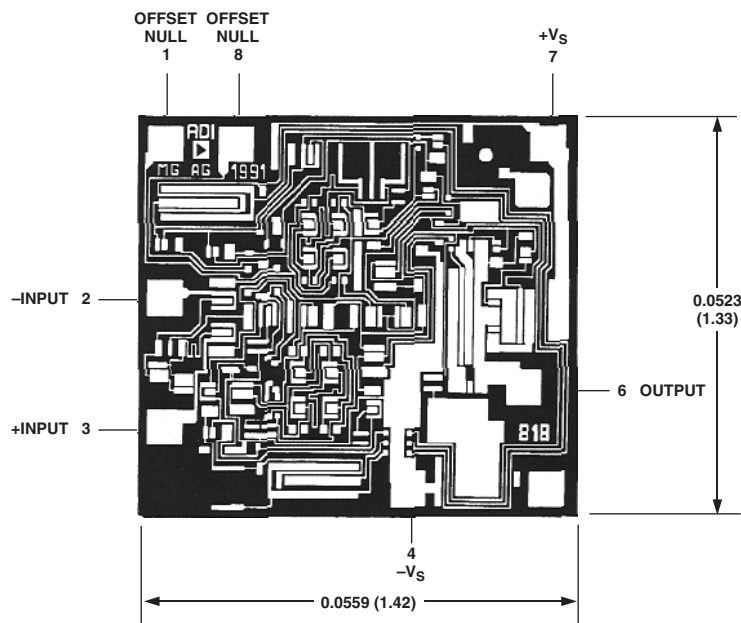

OUTLINE DIMENSIONS

8-Lead Plastic Dual In-Line Package [PDIP]
(N-8)

Dimensions shown in inches and (millimeters)

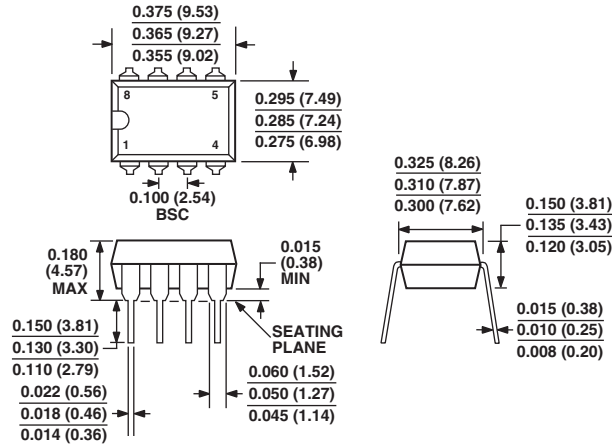

COMPLIANT TO JEDEC STANDARDS MO-095AA
CONTROLLING DIMENSIONS ARE IN INCHES; MILLIMETER DIMENSIONS (IN PARENTHESES) ARE ROUNDED-OFF INCH EQUIVALENTS FOR REFERENCE ONLY AND ARE NOT APPROPRIATE FOR USE IN DESIGN

8-Lead Standard Small Outline Package [SOIC]
(R-8)

Dimensions shown in millimeters and (inches)

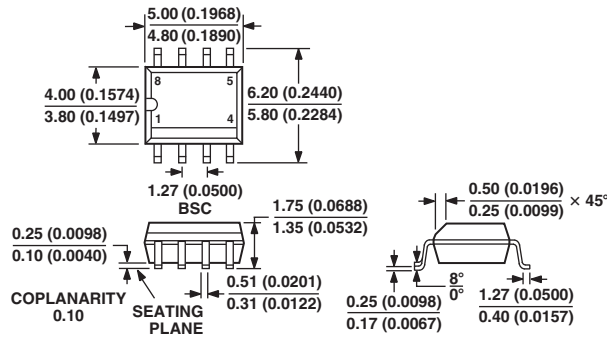

COMPLIANT TO JEDEC STANDARDS MS-012AA
CONTROLLING DIMENSIONS ARE IN MILLIMETERS; INCH DIMENSIONS (IN PARENTHESES) ARE ROUNDED-OFF MILLIMETER EQUIVALENTS FOR REFERENCE ONLY AND ARE NOT APPROPRIATE FOR USE IN DESIGN