

4

3

2

1

THIS DRAWING IS UNPUBLISHED. RELEASED FOR PUBLICATION 2003  
 © COPYRIGHT 2003 BY TYCO ELECTRONICS CORPORATION. ALL RIGHTS RESERVED.

LOC	DIST	REVISIONS				
P	LTR	DESCRIPTION	DATE	DWN	APVD	
B		EGC0-0021-04	23JAN2004	witt	-	

Matrize in Kombination mit Ergocrimp Basishandzange PN 539635-1 verwenden  
 Use die in combination with Ergocrimp basis hand tool PN 539635-1

Matrize im Karton mit Bedienungsanleitung 411-18132 verpackt  
 Die packed in a cardboard with instruction sheet 411-18132

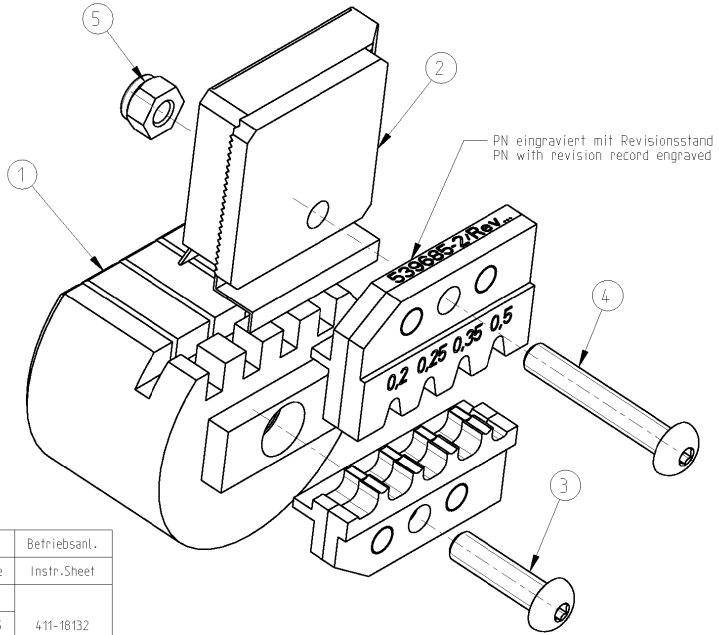

539685-2	1	9-0744001-6	Instruction Sheet	Bedienungsanleitung	6
	1	0-0519024-2	Nut M4 DIN 985	Mutter M4 DIN 985	5
	1	1-0519151-3	Screw M4x25	Schraube M4x25	4
	1	1-0519151-1	Screw M4x16	Schraube M4x16	3
	1	1-1579015-8	Locator Assembly	Drahtanschlag	2
	1	0-0539786-4	Contact Locator	Kontaktpositionierern	1
QTY	PN	Description	Benennung	Pos.	

Kontakt	DGB (mm <sup>2</sup> )	Drahtcrimp / Wire Crimp		Isolationscrimp/Insulationcrimp		Isol.Ø	Betriebsanl.
Contact	Wire Range	Höhe/Height mm	Breite/Width mm	Höhe/Height mm	Breite/Width mm	Ins.Range	Instr. Sheet
963727 / 963728	0.20	0.69 ±0.03	1.40	2.8 ±0.2	2.8	1.15-1.35	411-18132
	0.25	0.72 ±0.03		2.8 ±0.2		1.25-1.45	
	0.35	0.76 ±0.03		2.8 ±0.2		1.2-1.4	
	0.50	0.86 ±0.03		2.8 ±0.2		1.4-1.6	

<small>THIS DRAWING IS A CONTROLLED DOCUMENT FOR TYCO ELECTRONICS CORPORATION                  IT IS SUBJECT TO CHANGE AND THE CONTROLLING ENGINEERING ORGANIZATION                  SHOULD BE CONTACTED FOR THE LATEST REVISION.</small>		DWN Ch.Witt	23JAN2004	<b>tyco</b> Electronics tyco Electronics AMP GmbH D - 64625 Bensheim
DIMENSIONS: mm 		CHK -	-	
TOLERANCES UNLESS OTHERWISE SPECIFIED: 0 PLC ±0.1 1 PLC ±0.1 2 PLC ±0.1 3 PLC ±0.1 4 PLC ±0.1 ANGLES ±0.5° FINISH -		APVD -	-	NAME ERGOCRIMP - DIE SET Ergocrimp Matrize
MATERIAL -		PRODUCT SPEC -	-	RESTRICTED TO -
		APPLICATION SPEC -	-	SIZE A3
		WEIGHT -	-	CAGE CODE 00779
		CUSTOMER DRAWING		DRAWING NO G-539685-2
		SCALE 2:1		SHEET 1 OF 1
		REV B		

AMP 1470-19 REV 31MAR2000

Pro/ENGINEER DRAWING