

AMPAMP INCORPORATED
HARRISBURG, PA 17105APPLICATION AND MAINTENANCE
FOR AMP* CRIMPING DIE ASSEMBLIES
58380-1 AND 58380-2

REDUCED FOR PACKAGING

IS 9433CUSTOMER HOTLINE
1 800 722-1111RELEASED
9-7-88

Section I of this instruction sheet provides application procedures for AMP crimping die assemblies.

Section II provides maintenance and inspection procedures for AMP crimping die assemblies.

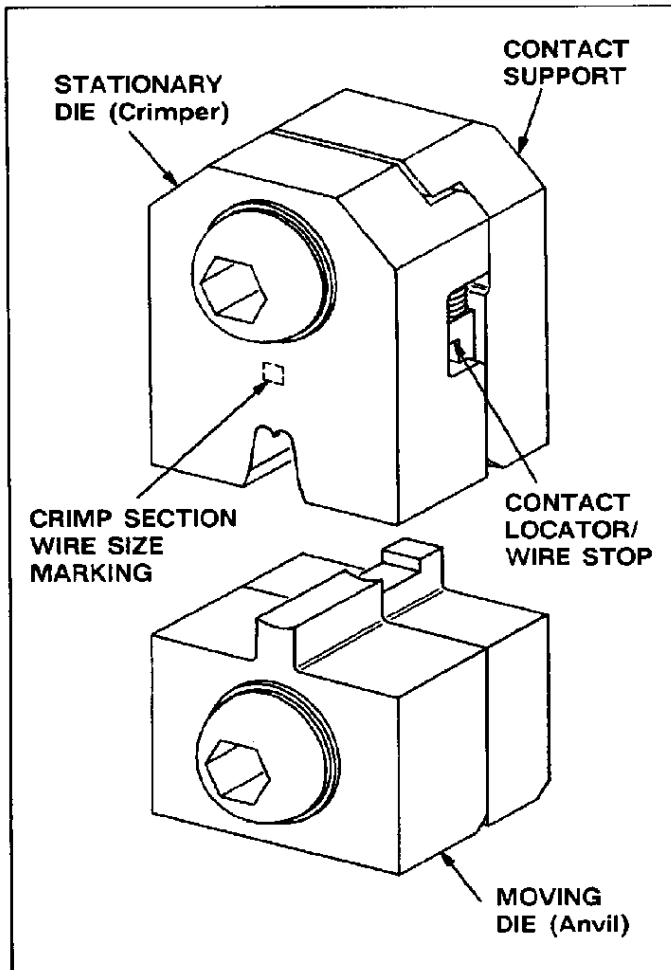
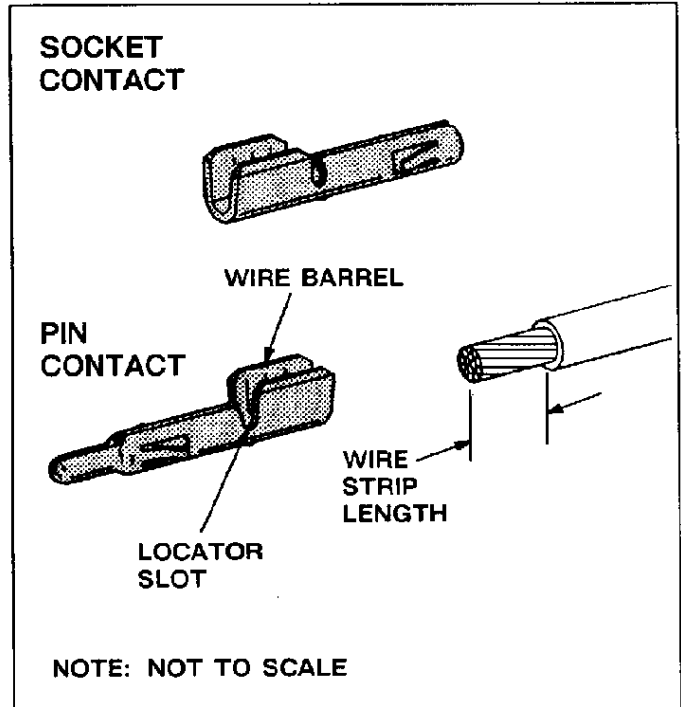

Fig. I-1



WIRE		CONTACT		DIE ASSEMBLY PART NO.
SIZE (AWG)	STRIP LENGTH	TYPE	PART NUMBER	
12	.250 to .281	Pin	770246	58380-1
		Socket	770247	
10	.250 to .281	Pin	770246	58380-2
		Socket	770247	

Fig. I-2

SECTION I APPLICATION**I-1. INTRODUCTION**

AMP Crimping Die Assemblies 58380-1 and 58380-2 are designed for use in AMPORAPOWER* Pneumatic Tool 69365 or in AMP Hand Crimping Tool 69710. The die assemblies, when installed in a tool, crimp the AMP MATE-N-LOK* loose piece contacts listed in Figure I-2.

This document provides specific information concerning the die assemblies and applicable contacts. Refer to AMP Customer Manual CM 1983, packaged with the pneumatic tool, or AMP Instruction Sheet IS 2095, packaged with the hand tool, for information concerning die insertion, contact crimping, and general performance of the tools.

NOTE

All dimensions presented are in inches.

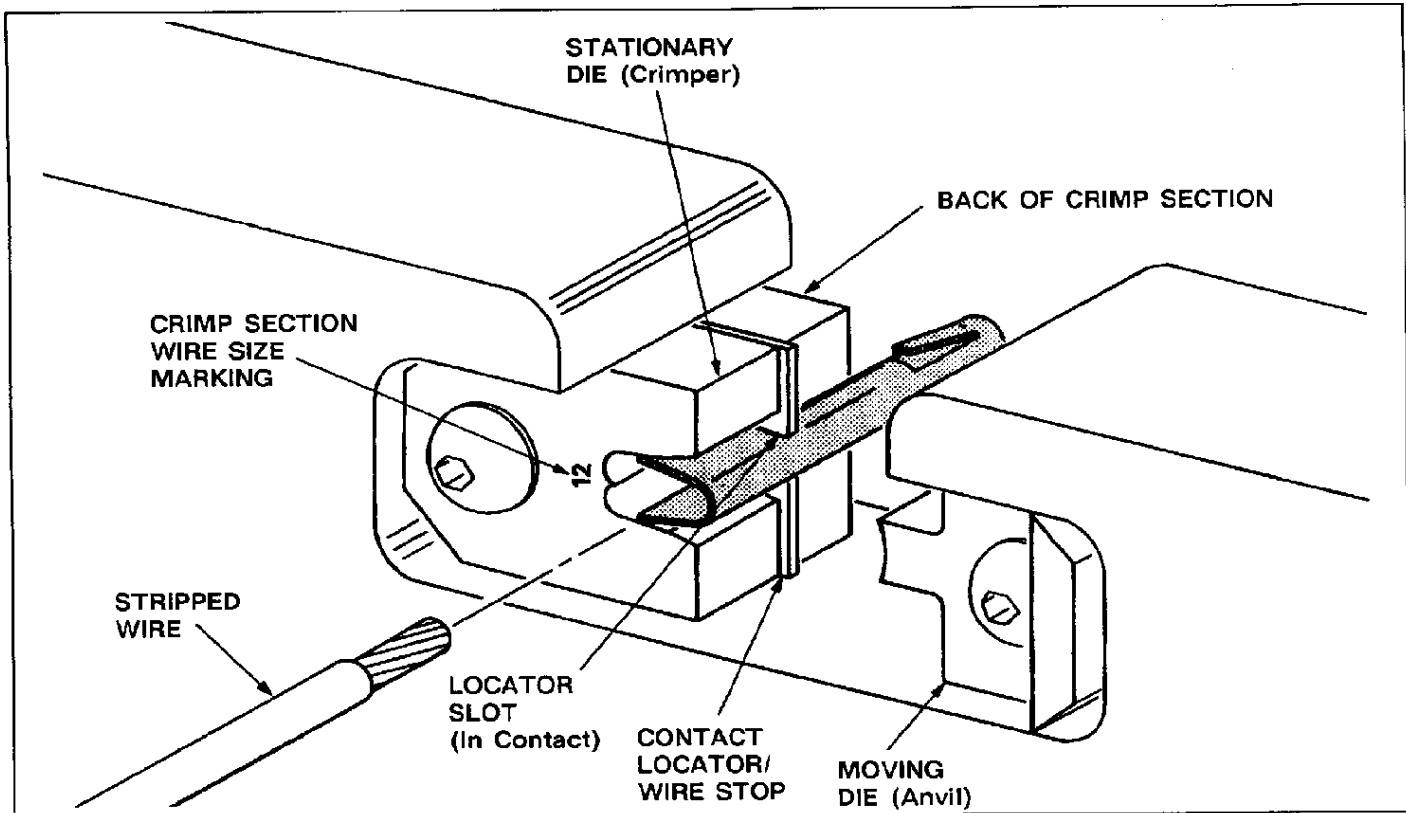

Fig. I-3

I-2. DESCRIPTION (Figure 1)

Each die assembly features a stationary die (crimper), a moveable die (anvil), a contact locator/wire stop, and a contact support.

The stationary die has chamfered corners and features a wire size marking above the crimp section. The moving die has square corners.

The contact locator/wire stop has two functions. It positions the contact in the crimping dies and also aids in locating the wire in the contact. In use it rests in the contact locator slot (see Figures I-2 and I-3). The contact support prevents the contact from bending during the crimping procedure.

I-3. CRIMPING PROCEDURE

Install the die assembly in the tool according to the instructions packaged with the tool.

Refer to the table in Figure I-2 and select wire of the specified size. Strip the insulation from the wire to the length indicated, taking care not to nick or cut wire strands.

Select an applicable loose piece contact and refer to Figure I-3. Proceed as follows:

1. Looking straight into the FRONT of the crimp section, insert contact (wire barrel first) into the

BACK of the crimp section. Position the contact in the crimpers so that the locator enters the locator slot in the contact.

2. Hold the contact in this position and close dies just enough to hold the contact in place without deforming the wire barrel.
3. Insert a properly stripped wire into the contact wire barrel until it butts against the contact locator/wire stop.
4. Holding the wire in place, actuate the tool through a complete cycle according to instructions packaged with the tool.
5. Allow the moving die to open FULLY and remove crimped contact.

I-4. DAILY MAINTENANCE

Remove all foreign particles from the dies with a clean, soft brush, or a clean, soft, lint-free cloth. Do not use objects that could damage the dies. If foreign matter cannot be easily removed, or if the proper replacement parts are not available, return the dies to your supervisor.

Check die alignment and tighten die holding screws on a regular schedule; twice daily is recommended for production use. Make certain that the dies are protected with a thin coat of any good SAE No. 20 motor oil. Do not oil excessively. When the dies are not in use, store them in a clean, dry area.

Section I of this instruction sheet provides application procedures for AMP crimping die assemblies.

Section II provides maintenance and inspection procedures for AMP crimping die assemblies.

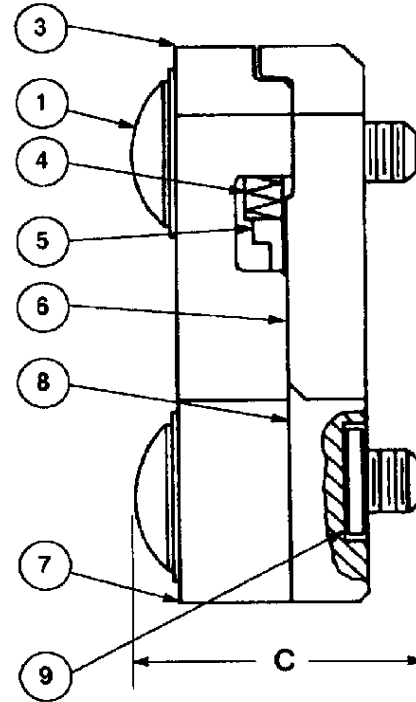
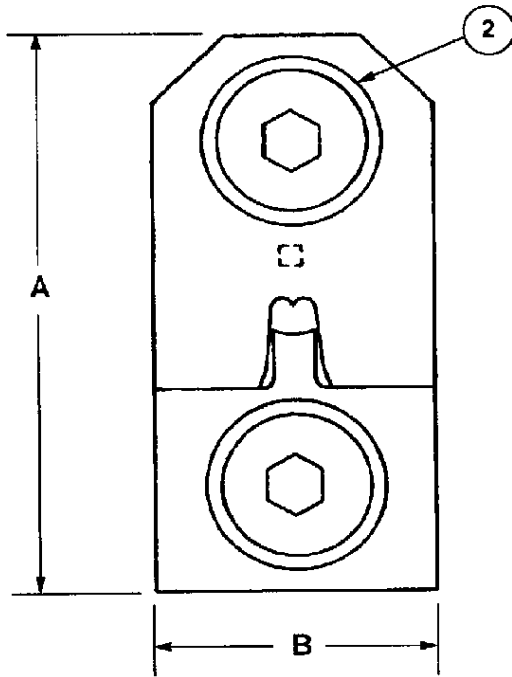

SPECIFICATIONS		REPLACEMENT PARTS				
		ITEM	PART NUMBER		DESCRIPTION	QTY
DIMENSION		DIE ASSEMBLY 58380-1	DIE ASSEMBLY 58380-2			
A	1.312	1	1-306593-4	1-306593-4	SCREW, Die Holding	2
B	.625	2	24088-7	24088-7	WASHER, Curved	2
C	.640	3	314101-1	314101-2	CRIMPER, Wire	1
WEIGHT		4	305182	305182	SPRING	2
		5	127005-2	127005-2	LOCATOR, Wire Stop	1
4 oz Approximate (All)		6	314102-1	314102-1	SUPPORT, Upper	1
		7	314104-1	314104-2	ANVIL, Wire	1
		8	314103-1	314103-1	SUPPORT, Wire Anvil	1
		9	1-21046-3	1-21046-3	RING, Retaining	2

Fig. II-1

SECTION II MAINTENANCE/INSPECTION

II-1. DIE ASSEMBLY CERTIFICATION

These instructions have been approved by AMP design, production, and quality control engineers to provide documented maintenance/inspection procedures in accordance with AMP Corporate Procedure No. 3-3. Through AMP test laboratories and the inspection of production assembly, the procedures described have been established to ensure the quality and reliability of AMP crimping die assemblies.

Customer-replaceable parts are listed in Figure II-1. A complete inventory should be stocked and controlled

to prevent lost time when replacement of parts is necessary.

II-2. INSPECTION PROCEDURES

A. Daily Maintenance

It is recommended that each operator of the die assemblies be made aware of, and responsible for, the following four steps of daily maintenance:

1. Remove dust, moisture, and other contaminants from the dies with a clean brush or a clean, soft, lint-free cloth. Do not use objects that could damage the dies.

2. Make sure that the proper die holding screws are in place and are secured with the proper washers and retaining rings.
3. Make certain that the dies are protected with a thin coat of any good SAE No. 20 motor oil. Do not oil excessively.
4. When the dies are not in use, store them in a clean, dry area.

B. Periodic Inspection

Regular inspections should be performed by quality control personnel with a record of scheduled inspection remaining with the dies or supplied to supervisory personnel responsible for them. Though recommendations call for at least one inspection per month, inspection frequency should be based upon amount of use, working conditions, operator training and skill, and established company standards. The inspections should be performed in the following sequence:

B-1. Visual Inspection

1. Remove all lubrication and accumulated film by immersing the dies in a suitable commercial degreaser that will not affect paint or plastic material.
2. Make sure that all holding screws, washers, retaining rings, and die components are in place. Refer to the parts listed in Figure II-1 if replacements are necessary.
3. Check all bearing surfaces for wear. Replace worn components.
4. Inspect the crimp section for flattened, chipped, cracked, worn, or broken areas. If damage is evident, the dies must be repaired before returning them to service. See Paragraph II-3, REPAIR.

B-2. Crimp Height Inspection

This inspection requires the use of a micrometer with a modified anvil, as shown in Figure II-2. AMP recommends the modified micrometer (Crimp Height Comparator RS-1019-5L) which may be purchased from:

York Machinery & Supply Co. VALCO
20 North Penn Street or 1410 Stonewood Drive
York, PA 17401-1014 Bethlehem, PA 18017-3527

The procedure is as follows:

1. Refer to the table in Figure II-2 and select a contact and a wire for the crimping die to be inspected.

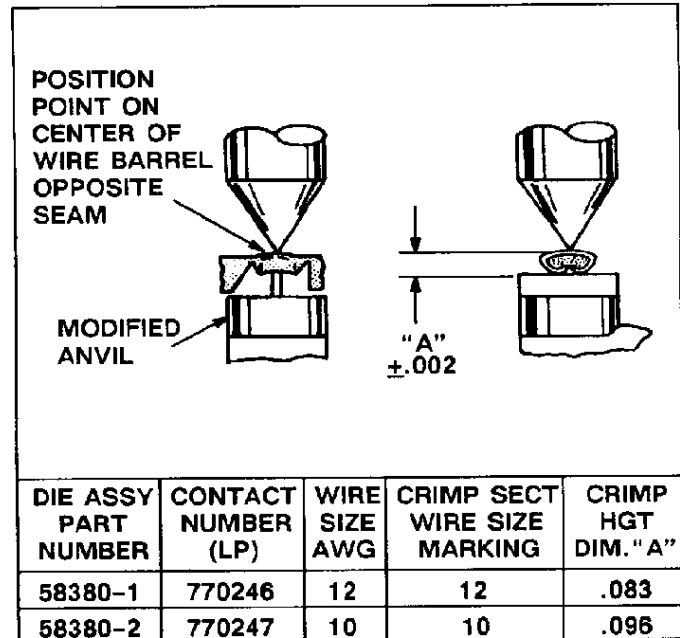

Fig. II-2

2. Refer to Paragraph I-3, CRIMPING PROCEDURE, and crimp a contact accordingly.

3. Using the crimp height comparator, measure the wire barrel crimp height as shown in Figure II-2. If the crimp height conforms to the dimension indicated in Figure II-2, the die assembly is considered dimensionally correct. If not, return the die assembly to AMP for evaluation and repair (see Paragraph II-3, REPAIR). For additional information concerning the use of the crimp height comparator, refer to AMP Instruction Sheet IS 7424.

II-3. REPAIR

The parts listed in Figure II-1 are customer-replaceable. A complete inventory may be stocked and controlled to prevent lost time when replacement of parts is necessary. The die assemblies may also be returned to AMP for evaluation and repair. Send the die assembly, with a written description of the problem, to:

AMP Incorporated
Customer Repair
1523 North 4th Street
Harrisburg, PA 17102-1604

or a wholly-owned subsidiary of AMP Incorporated.