*Totally Logical*

## Z8937101ZAC

### Z89371 ACCESSORY KIT

#### GENERAL DESCRIPTION

The Z89371 Accessory Kit is specifically designed to enable the Z8932101ZEM Emulator to program the Z89371 OTPs, and to perform in-circuit emulation.

#### SUPPORTED DEVICES

| Packages    | OTP Programming | In-Circuit Emulation |
|-------------|-----------------|----------------------|
| 44-pin PLCC | Z89371          | Z89371               |
| 44-pin QFP  | Z89371          |                      |
| 40-pin DIP  |                 | Z89371               |

#### SPECIFICATIONS

##### Operating Temperature

20°C, ±10°C

##### Operating Humidity

10%–90% RH (noncondensing)

#### PACKAGE CONTENTS

##### Hardware

Z89371 PLCC Programming Adapter (99C0599-001)

Z89371 QFP Programming Adapter (99C0386-001)

40-pin DIP Emulation Pod (99C0368-001)

44-pin PLCC Emulation Pod and cable assembly (93C0039-001)

Emulation Pod Adapter (99C0601-001)

##### Documentation

Data Sheet

##### Additional Items Required (Not Supplied)

Z8932101ZEM or Z8932102ZEM Emulator as OTP Programmer

DSP ICE GUI Software, version C3.12A or later

## PROGRAMMING ADAPTER INSTALLATION PROCEDURE

1. Ensure that all the necessary hardware and software is properly installed.
2. Plug the appropriate Programming Adapter into the 40-pin DIP socket of the ZEM emulator. Carefully align pin 1 of the adapter to pin 1 of the 40-pin socket.
3. Power up the system.
4. Start the DSP GUI application.
5. Open either the DSP Code Memory window or the Debug window.
6. Select the File menu to download the object code to be programmed.
7. Select the OTP menu item.
8. Make sure the device label faces up. Plug a Z89371 OTP device into the 44-pin ZIF socket of the programming adapter. Carefully align pin 1 of the OTP with the silk screen marker of pin 1 on the programming adapter board. Insert the OTP device gently, and let it sit tight and flat inside the ZIF socket. For QFP devices, close the lid of the socket.
9. Begin programming by clicking the Program button on the DSP GUI.
10. After successful programming, remove the device by pushing the socket down and popping the OTP device out of the socket.

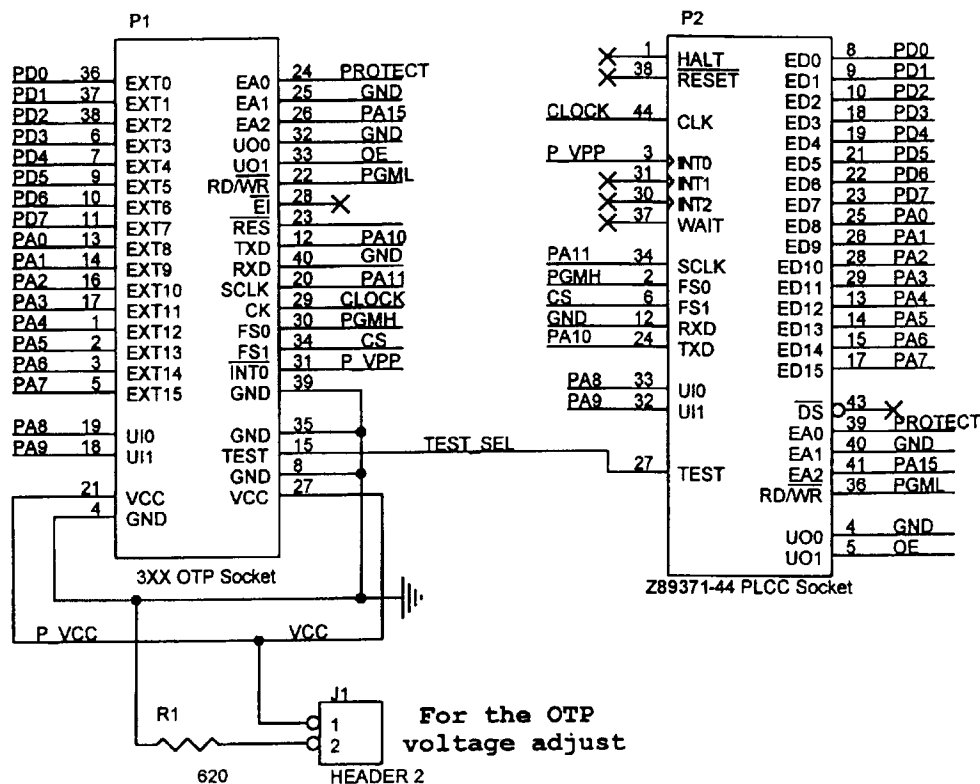

Figure 1. Schematic for Z89371 PLCC Programming Adapter

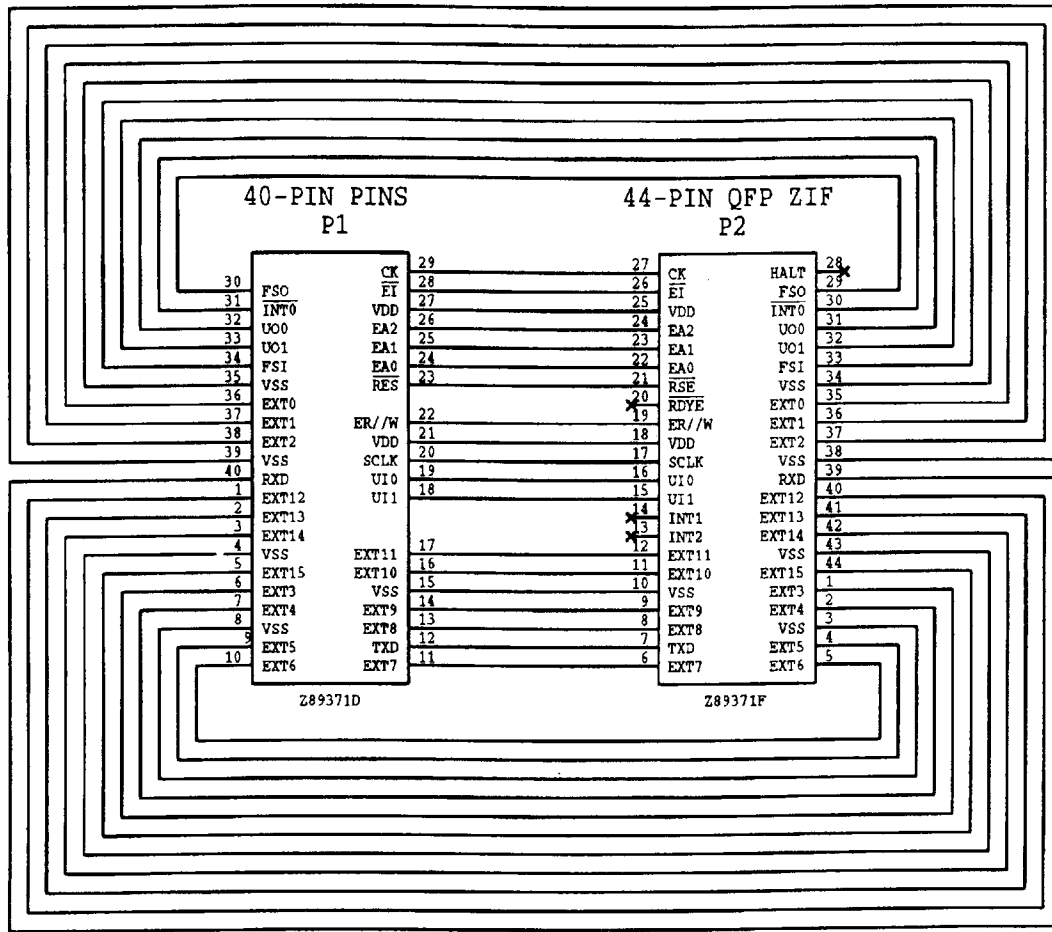

Figure 2. Schematic for Z89371 QFP Programming Adapter

## EMULATION POD INSTALLATION PROCEDURE

1. Ensure that all the necessary emulator hardware and software is properly installed. Turn off all power associated with the emulator and target application.
2. Line up the sockets on the Emulation Pod Adapter with the header pins on the Z8932101ZEM. Place P1 on the adapter over P1 on the emulator board, and P2 over P2, respectively. Press the adapter firmly down into place.
3. Plug the Emulation Pod cable into the Yamaichi 40x2 pin connector on the Emulation Pod Adapter.
4. Line up pin1 on the emulator pod with pin 1 on the target application socket. Insert the pod into the socket.
5. Power up the emulator, then press the RESET button.
6. Power up the target application.
7. Open the Debug and the DSP Code Memory Windows.
8. Select the File menu to download the application or object code to be executed during emulation.
9. Begin emulation by pressing the GO button in the GUI Debug window.
10. After successful emulation, first power down the target application board.
11. Remove the emulation pod from the target.
12. Power down the emulator.

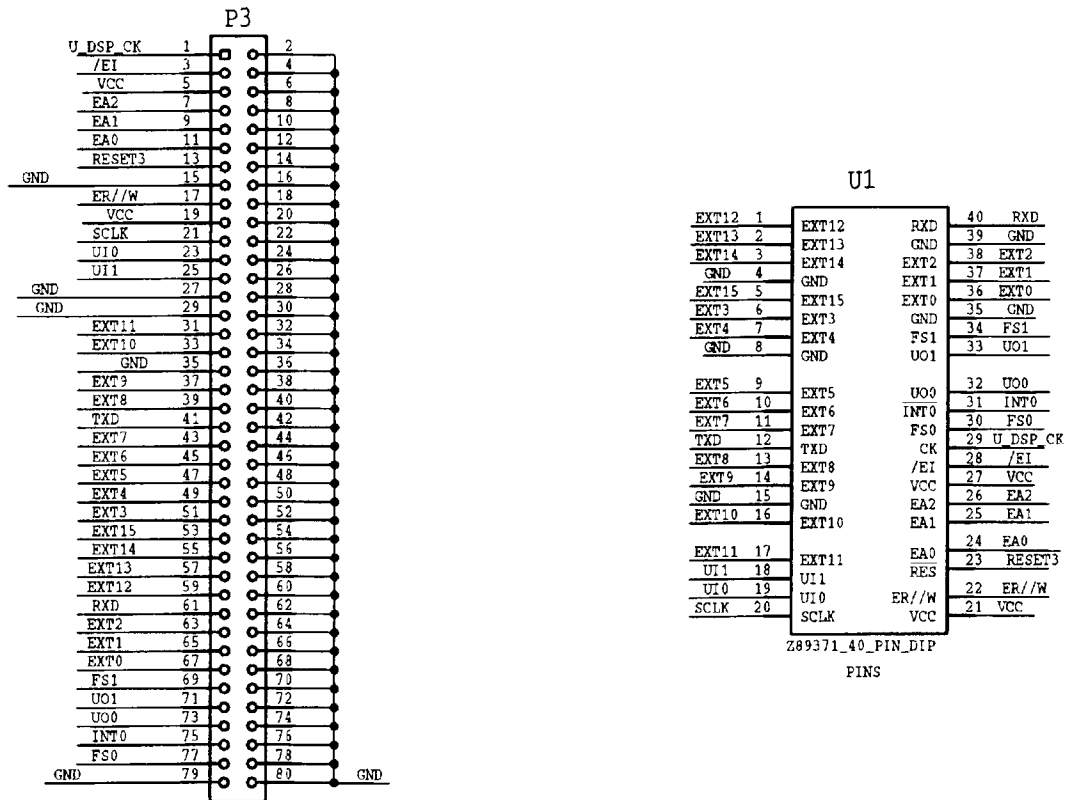

Figure 3. Schematic for Z89371 40-pin DIP Emulation Pod

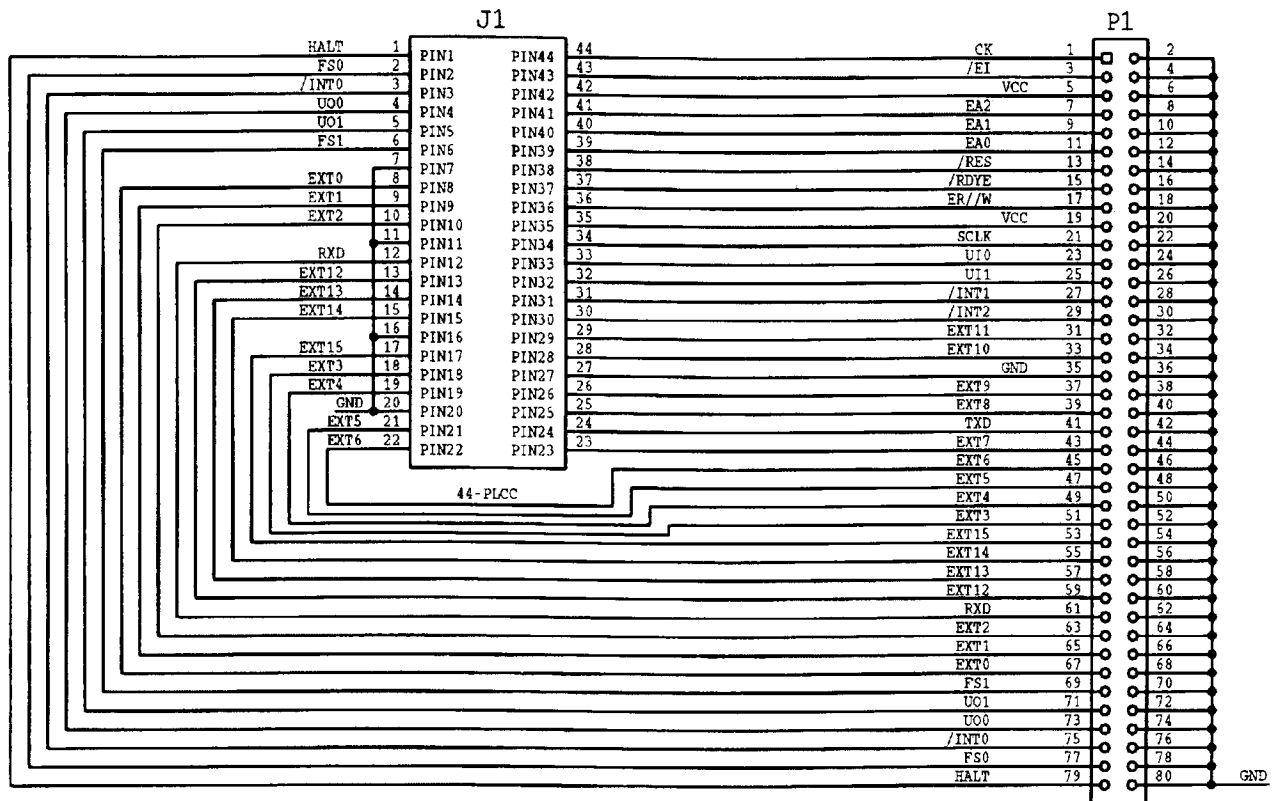

Figure 4. Schematic for Z89371 PLCC Emulation Pod

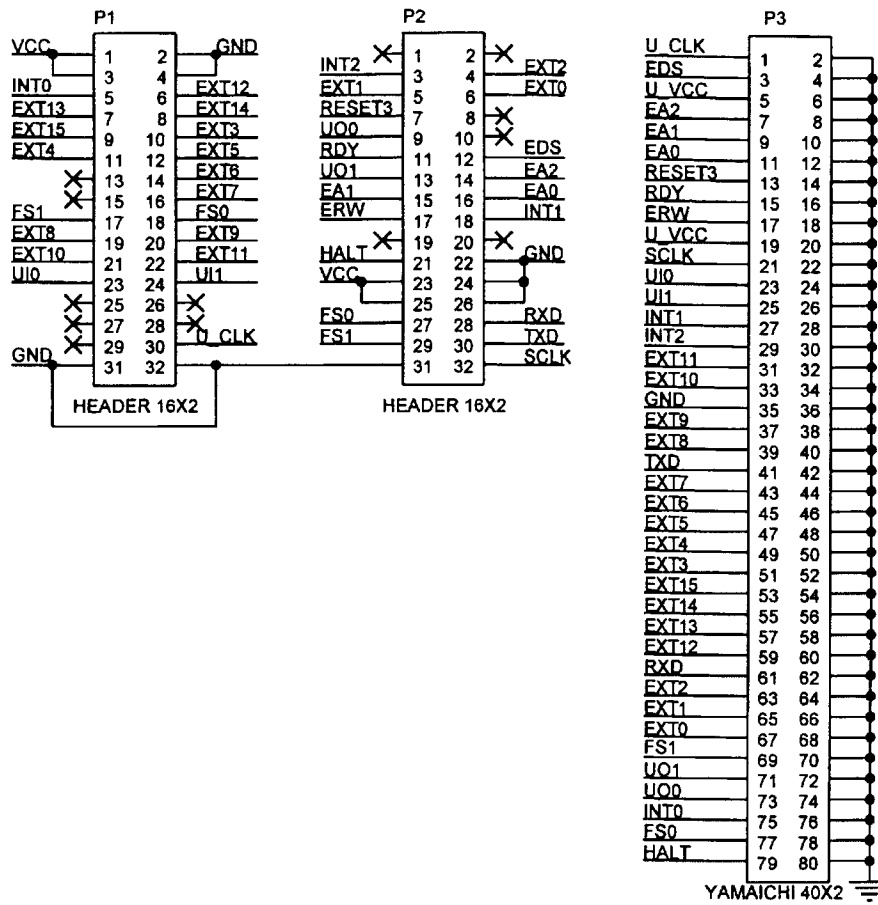

Figure 5. Schematic for Z89321 Emulation Pod Adapter

---

© 1998 by ZiLOG, Inc. All rights reserved. No part of this document may be copied or reproduced in any form or by any means without the prior written consent of ZiLOG, Inc. The information in this document is subject to change without notice. Devices sold by ZiLOG, Inc. are covered by warranty and patent indemnification provisions appearing in ZiLOG, Inc. Terms and Conditions of Sale only.

ZILOG, INC. MAKES NO WARRANTY, EXPRESS, STATUTORY, IMPLIED OR BY DESCRIPTION, REGARDING THE INFORMATION SET FORTH HEREIN OR REGARDING THE FREEDOM OF THE DESCRIBED DEVICES FROM INTELLECTUAL PROPERTY INFRINGEMENT. ZILOG, INC. MAKES NO WARRANTY OF MERCHANTABILITY OR FITNESS FOR ANY PURPOSE.

ZiLOG, Inc. shall not be responsible for any errors that may appear in this document. ZiLOG, Inc. makes no commitment to

update or keep current the information contained in this document.

ZiLOG's products are not authorized for use as critical components in life support devices or systems unless a specific written agreement pertaining to such intended use is executed between the customer and ZiLOG prior to use. Life support devices or systems are those which are intended for surgical implantation into the body, or which sustains life whose failure to perform, when properly used in accordance with instructions for use provided in the labeling, can be reasonably expected to result in significant injury to the user.

ZiLOG, Inc.  
910 East Hamilton Avenue, Suite 110  
Campbell, CA 95008  
Telephone (408) 558-8500  
FAX 408 558-8300  
Internet: <http://www.zilog.com>

---