

Evaluation Board for STR71xF

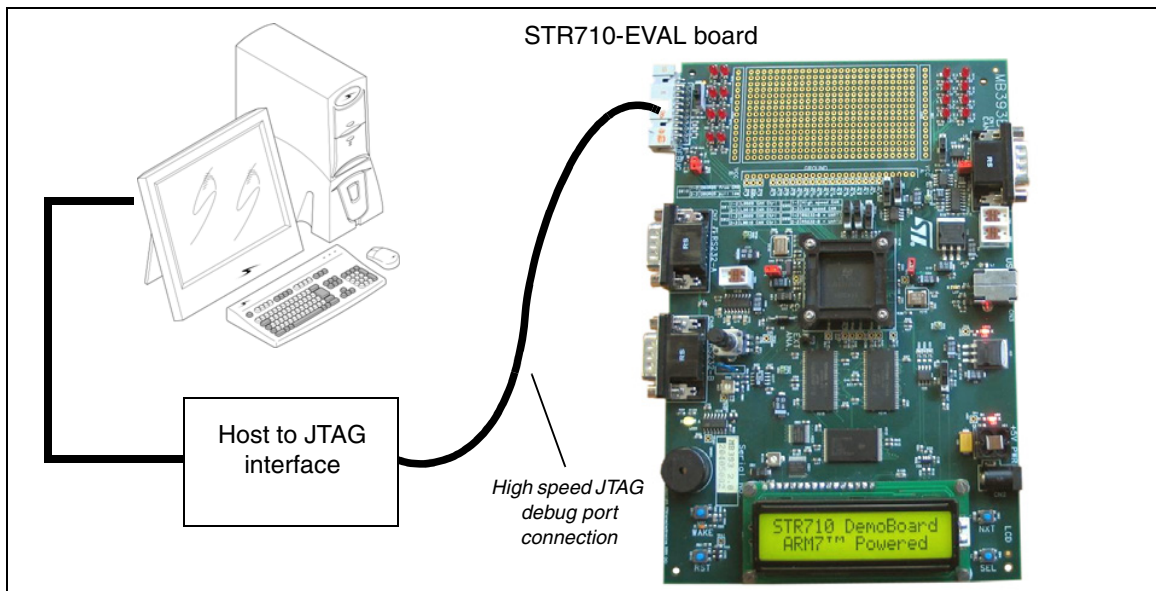

Main components

- STR710F processor running at 48 MHz
- EMI SRAM 4 Mbytes (2M x 16)
- EMI flash 4 Mbytes (2M x 16)
- SPI serial flash
- I²C EEPROM
- LCD display

Features

- Support for the following interfaces:
 - USB
 - CAN
 - RS232
- LED displays
- Buzzer
- Test buttons
- JTAG connector

Description

The STR710-EVAL board is a complete development platform for the STR71x series. It is a cost effective, flexible and open design to demonstrate the capability of the STR71x series of flash microcontrollers and to enable rapid evaluation of the STR71x devices and peripherals. It includes the high performance STR710FZ2T6 ARM7TDMI™ device with 256 Kbytes embedded flash with “best-in-class” random access time, 64 Kbytes on-chip high speed SRAM and up to 10 serial communication interfaces, including USB and CAN.

The STR710-EVAL board includes SRAM and flash memory on the EMI to enable full freedom in development of large programs before custom hardware is designed. It integrates a 2 x 16 LCD, LEDs, UART, CAN, USB interfaces, piezo buzzer and test buttons in a versatile stand-alone test platform. A wide choice of third party development tool support is readily available, in addition to those available from STMicroelectronics.

1	Introduction	2
1.1	Processor and memory devices on this board	2
1.2	Board interface connections	3
1.3	Push buttons	3
1.4	Displays	3
2	Hardware	4
2.1	Overview	6
2.2	Processor	6
2.3	Debug	6
2.4	Prototype area	6
2.5	Reset	6
2.6	Memory	6
2.7	Power supplies	6
2.8	USB full speed interface	6
2.9	CAN interface	7
2.10	RS232 serial interfaces	7
2.11	External analog	7
2.12	Analog input	7
2.13	LEDs	8
2.14	Option jumper placement	9
2.15	Option switch settings	10
3	Connectors	13
3.1	USB	13
3.2	CAN bus connector	13
3.3	External analog	13
3.4	RS232 serial data connector	14
3.5	Debug	14
4	Schematics	15
5	Revision history	25

1 Introduction

STMicroelectronics is a global independent semiconductor company that designs, develops, manufactures and markets a broad range of semiconductor integrated circuits and discrete devices used in a wide variety of applications.

The STR710-EVAL board is based on the STR710FZ2T6, a highly integrated microcontroller, running at 48 MHz that combines the popular ARM7TDMI™ 32-bit RISC CPU with 256 Kbytes of embedded flash, 64 Kbytes of high speed SRAM, and numerous on-chip peripherals.

This board is intended as low cost development platform to demonstrate the capability of the STR71x series of flash micro-controllers and to enable rapid evaluation of the STR71x devices and available peripherals.

The STR710-EVAL board has 4 Mbytes of SRAM, and 4 Mbytes of flash on EMI, 1-Mbit SPI serial flash and 8-kbits EEPROM. It supports USB, CAN and RS232 interfaces. The on-board chip STR710FZ2T6 is an ARM7TDMI™ 32-bit RISC micro-controller.

This board includes a 2x16 programmable LCD display supported by reset, next and select push buttons.

Because the STR710FZ2T6 is the superset of the STR71xF series, with 144-pin, EMI, 256 Kbytes of flash and 64 Kbytes of SRAM, an alternative use of the STR710-EVAL board is as an evaluation platform for STR711F and STR712F devices.

The hardware platform of the STR710F series is supported by an extensive software support package, including device drivers in ANSI C source form and demonstration software. It is flashed with a demonstration application that shows the basic features of the device. Development tools are readily available. This is complimented by a range of third party real-time OS and middleware.

Design schematics can also be supplied in electronic format to those customers with compatible design environments.

Note: ARM® and ARM7TDMI™ are registered trademarks of ARM Limited in the EU and other countries.

1.1 Processor and memory devices on this board

- STR710FZ2T6 ARM7TDMI™ processor running at 48 MHz, IC13:
 - 144-pin TQFP version,
 - 256 Kbytes flash program memory (100,000 cycles endurance),
 - 64 Kbytes RAM,
 - embedded 1.8 V voltage regulator for core supply (options to use the on-board 1.8 V regulator allows full speed operations,
 - nested interrupt controller.
- External memory interface:
 - flash (bank 0) 4 Mbytes arranged as 2M x 16: IC12,
 - SRAM (bank 1) 4 Mbytes arranged as 2M x 16: IC14, IC15.
- Clocking:
 - +3.3 V surface mounted 16 MHz oscillator provides the main clock source,

- RTC real-time clock for wakeup from standby mode with embedded 32 KHz oscillator.
- Serial ROMs:
 - 1-Mbit SPI serial flash connected to the buffered serial peripheral interface (BSPi): IC11,
 - I²C EEPROM: 8-kbit EEPROM connected to the I²C0 interface: IC9.

1.2 Board interface connections

Diagrams and wiring descriptions for these connectors are provided in [Section 4: Schematics on page 15](#). The following connections are supported by the board:

- USB, support USB device using a type B connector: CN3,
- CAN uses a single 9 D-type connector with microswitch selectable low or high speed transceiver: CN1,
- UART0 (Rx and Tx only) connected to a 9-way male D-type RS232 connector: CN7,
- UART1 and 2 (Rx and Tx only) switch selectable, connected to a 9-way male D-type RS232 connector: CN8 ,
- JTAG, 20 pin IDC connector: CN9,
- Piezo buzzer: SPKR1,
- variable resistor, voltage range 0 to 2.5 V: R63,
- prototype area: GD1,
- test points, various test points are located throughout the board, for details see [Section 4: Schematics on page 15](#),
- external analog: CN6,
- main power supply: CN2.

1.3 Push buttons

The following push buttons are provided:

- reset, board reset: SW12,
- wakeup, push button to bring processor out of low power mode: SW11,
- select, programmable switch: SW4,
- next, programmable switch: SW3.

1.4 Displays

The following LCD and LEDs are provided:

- LCD display, 2x16 LCD display connected to a parallel EMI LCD interface; green back light display: LCD1,
- surface mount red, +5 V and +3.3 V power indicators: LD1, LD2,
- surface mount orange, USB powered: LD7,
- surface mount orange indicates standby status: LD21,
- bi-color red/green: LD20,
- low consumption LEDs red: LD3, LD4, LD5, LD6, LD8, LD9, LD10, LD11, LD12, LD13, LD14, LD15, LD16, LD17, LD18, LD19.

Note: The LCD I²C0 connection may be used, although the I²C0 connector is not fitted.

2 Hardware

Figure 1. STR710-EVAL board layout block diagram

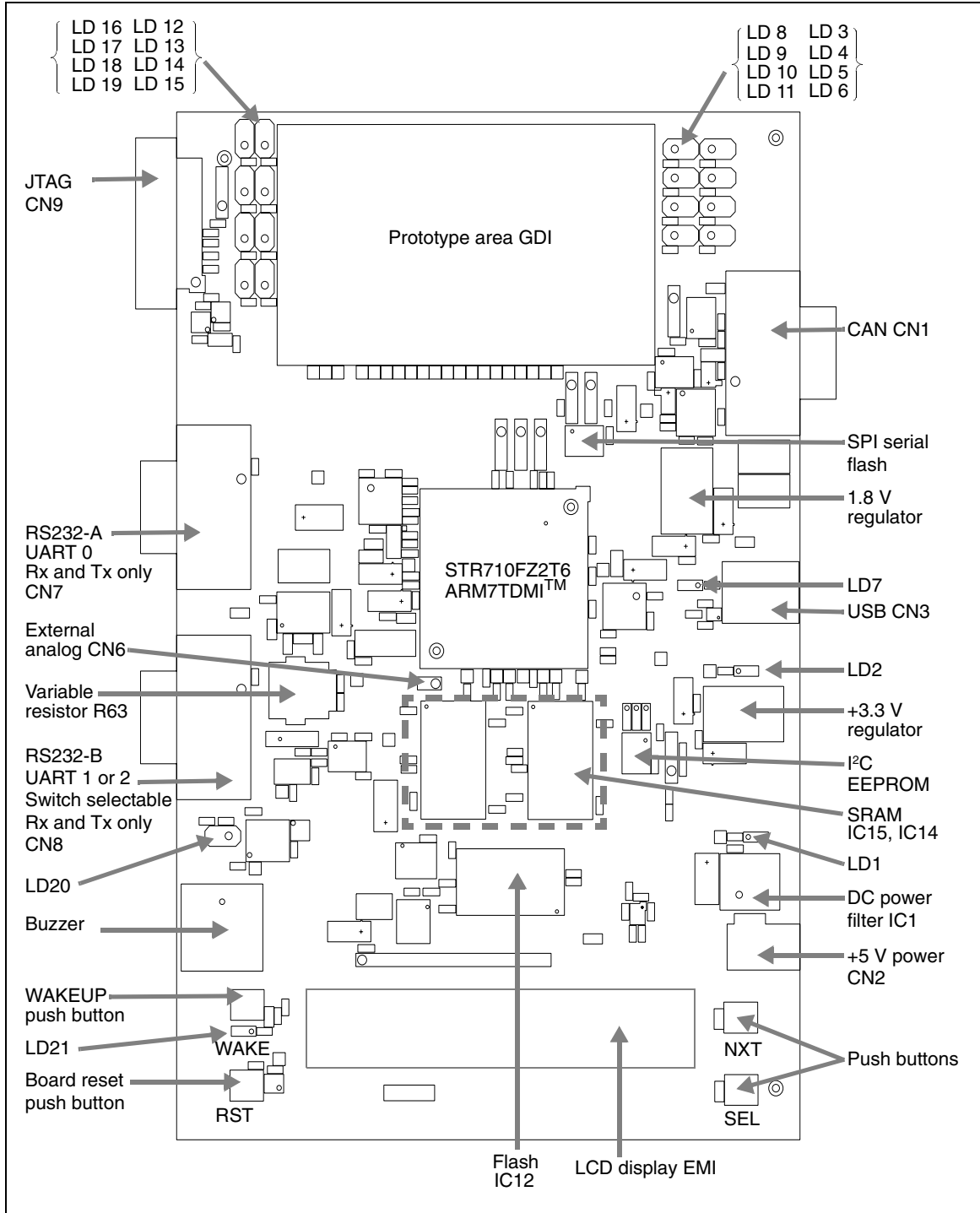
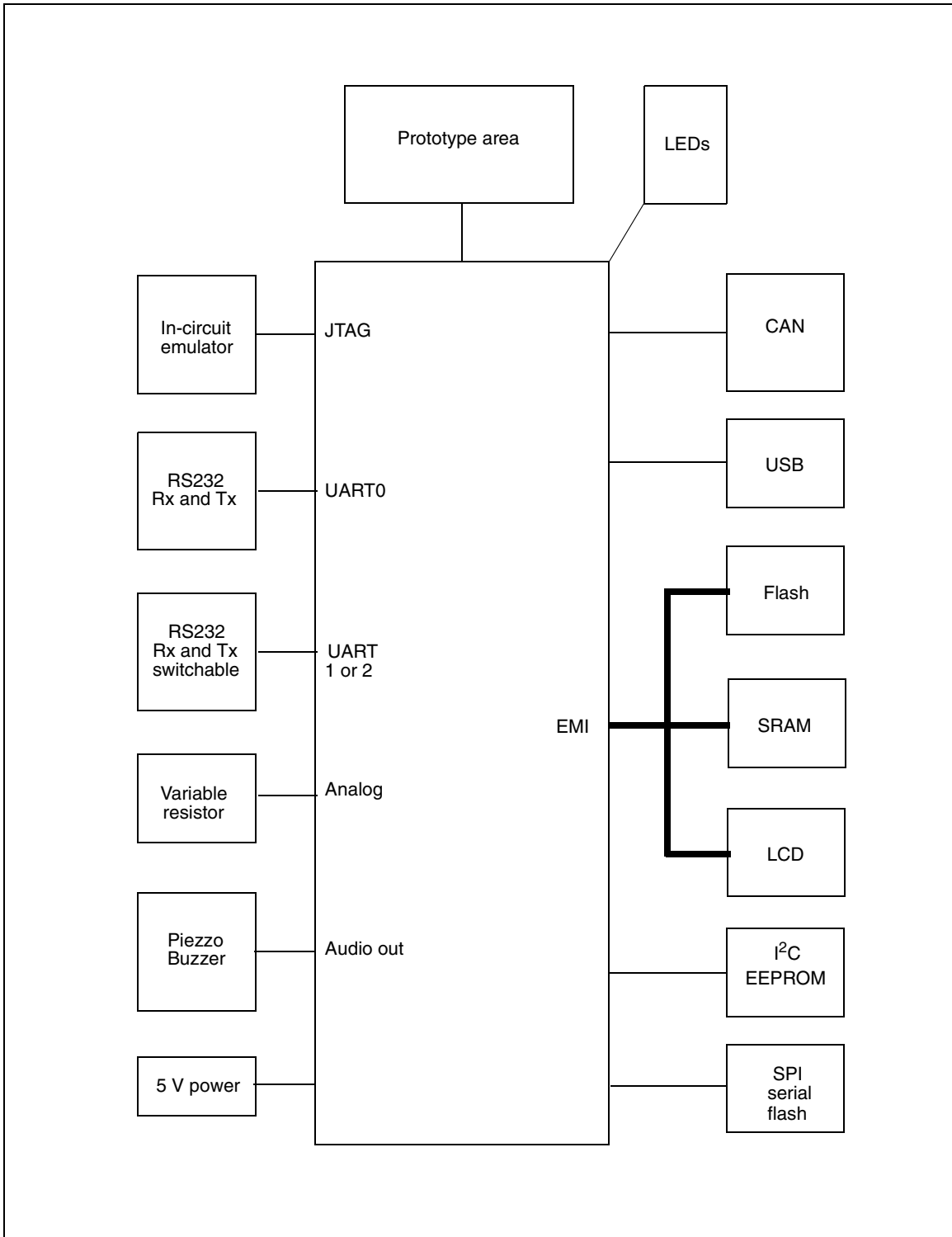

Figure 2. STR710-EVAL board system block diagram



2.1 Overview

The STR710-EVAL board is a general purpose evaluation platform with USB, CAN (controller area network) and RS232 interfaces.

2.2 Processor

The board supports the STR710FZ2T6 ARM7TDMI™ silicon - 144-pin TQFP version. This chip runs at a frequency of 48 MHz.

Boot modes and configuration options are set using microswitches.

2.3 Debug

Software debug is by a standard 20-pin JTAG connection. This may connect to a standard USB to JTAG in-circuit emulator.

2.4 Prototype area

A 2.54 x 2.54 mm gridded area of 1mm holes is available for prototyping using wire wrap or similar prototyping techniques.

2.5 Reset

The reset sources are:

- power on reset,
- push button reset,
- JTAG reset from an in-circuit emulator.

2.6 Memory

Table 1. STR710-EVAL board EMI memory map

Region	Use	Memory map used	Region space available
3	Unused	Not applicable	0x6600 0000 - 0x67FF FFFF
2	LCD	Address 2 is used as the LCD register address signal	0x6400 0000 - 0x65FF FFFF
1	SRAM	0x6200 0000 - 0x623F FFFF	0x6200 0000 - 0x62FF FFFF
0	Flash (boot bank)	0x6000 0000 - 0x603F FFFF	0x6000 0000 - 0x60FF FFFF

2.7 Power supplies

Power to the board is supplied using a lump in cord power supply providing 5 V to the board. All other required voltages are provided by on-board voltage regulators or voltage convertors.

2.8 USB full speed interface

USB full speed interface device supported by a type B connector. The USB clock uses a separate 48 MHz oscillator. See [Section 3.1: USB on page 13](#).

2.9 CAN interface

A general purpose, asynchronous serial I/O data port connected through a 9-pin D-type male connector with microswitch selectable low speed fault tolerant transceiver (L9669) or low or high speed selectable transceiver (L9615 or L9616). See [Section 3.2: CAN bus connector on page 13](#).

Caution: The board schematic for the CAN interface detailed in [Figure 16: CAN interface on page 20](#), is not a reference design and should not be copied. To design a CAN interface with the STR710 please refer to the “STR71x Hardware Development Getting Started Guide AN1775”.

2.10 RS232 serial interfaces

Two general purpose, asynchronous serial I/O data ports are connected through 9-pin D-type male connectors refer to [Section 3.4: RS232 serial data connector on page 14](#).

RS232-A connects directly to UART0, transmit and receive only. RS232-B connects to either UART1 or UART2 through switch 9, transmit and receive only.

RTS is shorted to CTS and DTR is shorted to DSR at the connector for both interfaces.

2.11 External analog

An external analog input connector is provided, see [Section 3.3: External analog on page 13](#) and [Figure 11: STR710-EVAL board top level page 1 of 2 on page 15](#).

2.12 Analog input

The analog input to ADC is demonstrated by the variable resistor R63. Although there is a thermistor connected up to the analogue input AIN.1 in the schematics [Figure 11: STR710-EVAL board top level page 1 of 2 on page 15](#), it is not functional and has been removed from the product.

2.13 LEDs

Software controlled LEDs

The LEDs in [Table 2](#) are software controlled by PIO pins. See the schematic in [Figure 11 on page 15](#).

Table 2. Software controlled LEDs

LED	Description	Color
LD20	LED_P1_2	Red/Green
LD3	LED_PO_3	Red
LD4	LED_PO_2	
LD5	LED_PO_1	
LD6	LED_PO_0	
LD8	LED_PO_12	
LD9	LED_P1_15	
LD10	LED_P2_9	
LD11	LED_P2_10	
LD12	LED_P2_11	
LD13	LED_P2_12	
LD14	LED_P2_13	
LD15	LED_P2_14	
LD16	LED_P2_15	
LD17	LED_P1_6	
LD18	LED_P1_5	
LD19	LED_P1_4	

Status LEDs

Table 3. Status LEDs

LED	Description	Schematic
LD1	+5 V	Figure 12 on page 16
LD2	+3.3 V	Figure 12 on page 16
LD7	Vbus	Figure 15 on page 19
LD21	not STDBY	Figure 11 on page 15

2.14 Option jumper placement

Figure 3. Option jumpers, resistors and switches

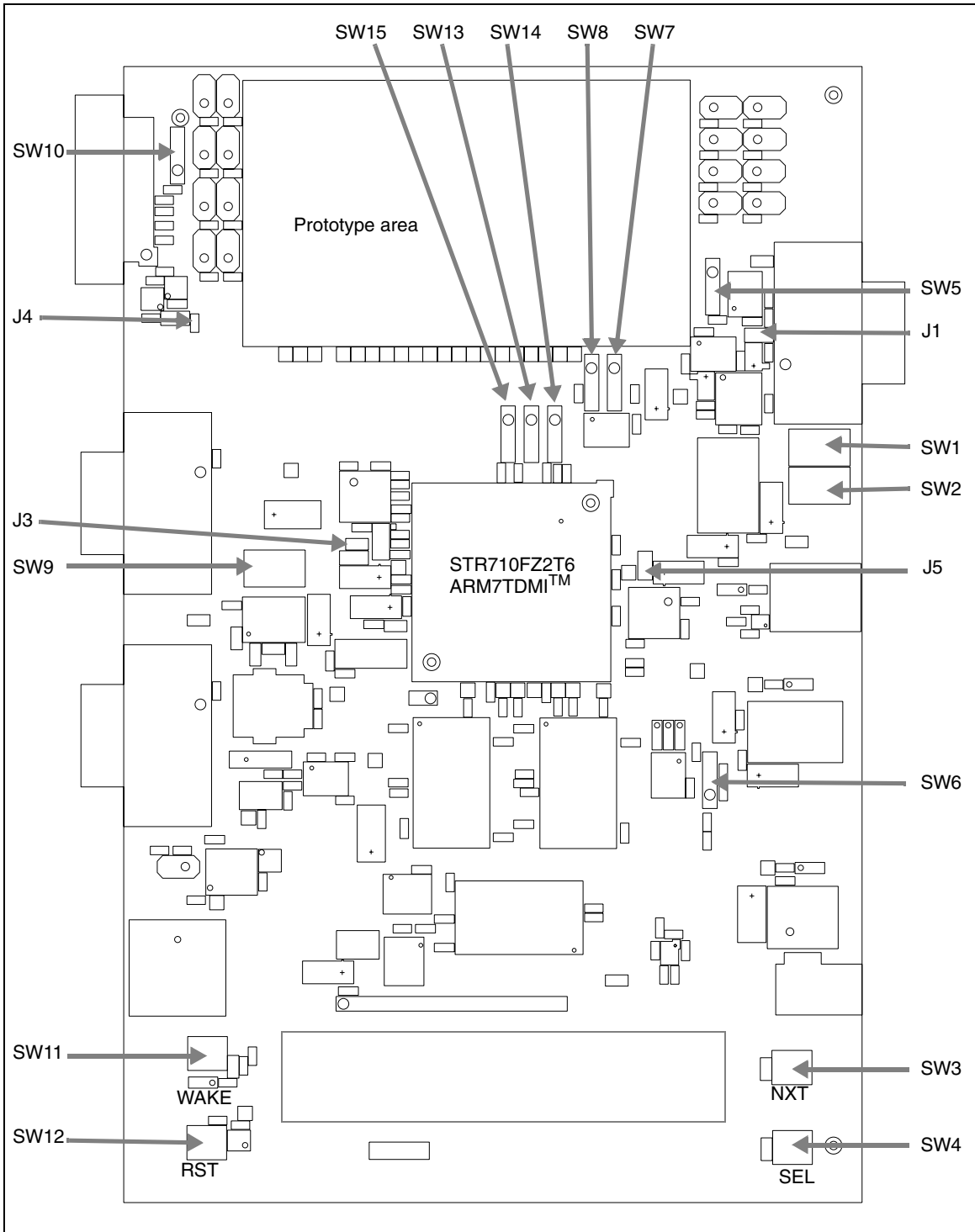
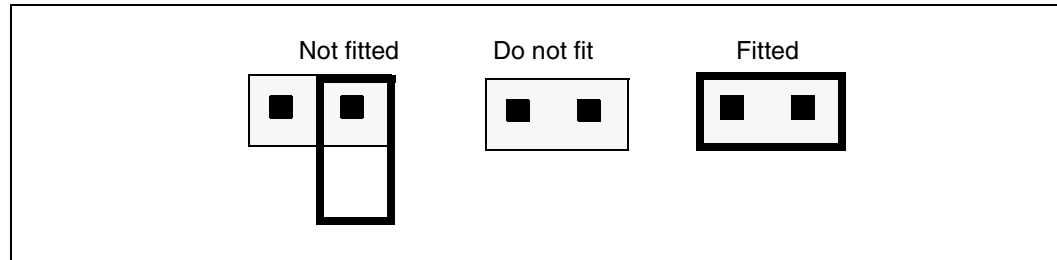

Table 4. Option jumpers

Jumper	Figure	Description	Default
J1	Figure 16 on page 20	CAN link: not fitted / fitted (default)	Fitted
J3	Figure 12 on page 16	VBKP supply: internal / board (default)	Fitted
J4	Figure 19 on page 23	notJRst / notReset link: connected / open (default)	Not fitted
J5	Figure 12 on page 16	Not fitted.	Do not fit

Jumpers are fitted as shown in [Figure 4](#).

Figure 4. Jumper positions

2.15 Option switch settings

Table 5. Option switch settings

Switch	Schematic	Description	Default
SW1	Figure 16 on page 20	CAN transceiver select: L9669 / L9616 (default) Note SW1 and SW2 must be changed together. 1 = L9669 A = L9616	ON
SW2			ON
SW3	Figure 11 on page 15	LCD Select	PTM
SW4	Figure 11 on page 15	LCD Next	PTM
SW5	Figure 16 on page 20	L9616 ASC speed: 1-2 = pull down = high speed 2-3 = pull up = low speed	2-3
SW6	Figure 17 on page 21	I ² C EEPROM write control (notWC): 1-2 = pull down = enable writes to EEPROM 2-3 = pull up = disable writes to EEPROM	2-3
SW7	Figure 17 on page 21	SPI flash notHOLD: 1-2 = pull down = SPI flash in "hold mode" 2-3 = pull up = SPI flash in "normal mode"	2-3
SW8	Figure 17 on page 21	SPI flash notW: 1-2 = pull down = Write protect 2-3 = pull up = Write enabled	2-3

Table 5. Option switch settings

Switch	Schematic	Description	Default
SW9	Figure 11 on page 15	RS232 source select: 1 = UART1 connected to RS232-B A = UART2 connected to RS232-B	1
SW10	-	Not fitted: do not fit	-
SW11	Figure 11 on page 15	Wake upL	PTM
SW12	Figure 11 on page 15	Reset	PTM
SW13	Figure 11 on page 15	Boot mode 1, see Table 6 on page 11 .	2-3
SW14	Figure 11 on page 15	Boot mode 0, see Table 6 on page 11 .	1-2
SW15	Figure 11 on page 15	Boot EN, see Table 6 on page 11 .	2-3

For switch position details, see [Figure 3: Option jumpers, resistors and switches on page 9](#).

Table 6. Boot modes

Boot EN (SW15)	Boot1 B1 (SW13)	Boot0 B0 (SW14)	Mode	Boot memory mapping	Notes	
1-2 2-3	any 1-2	any 1-2	USER	flash mapped at 0h	System executes code from flash	
2-3	1-2	2-3	BOOT	BOOTFLASH mapped at 0h	System executes a "primary boot loader (ST-firmware)" from Boot-FLASH then jumps to RAM Clock FROZEN	
2-3	2-3	1-2	RAM	RAM mapped at 0h	System executes code from internal RAM For Lab development	
2-3	2-3	2-3	EXTMEM	EXTMEM mapped at 0h	System executes code from external memory	

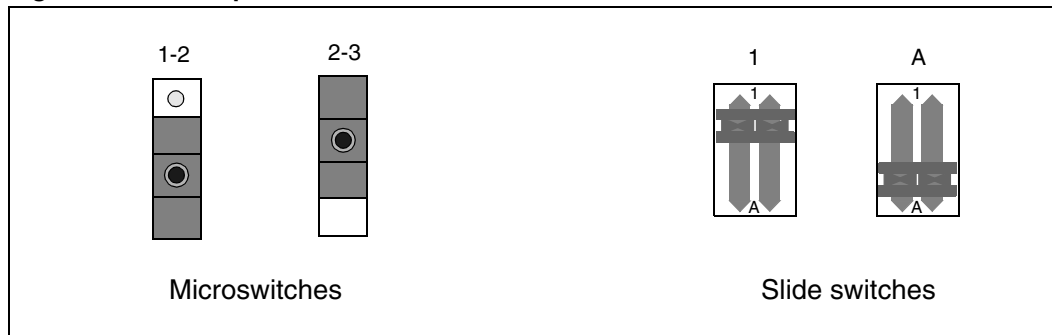
Figure 5. Switch positions

3 Connectors

3.1 USB

Figure 6. USB-B connector: CN3

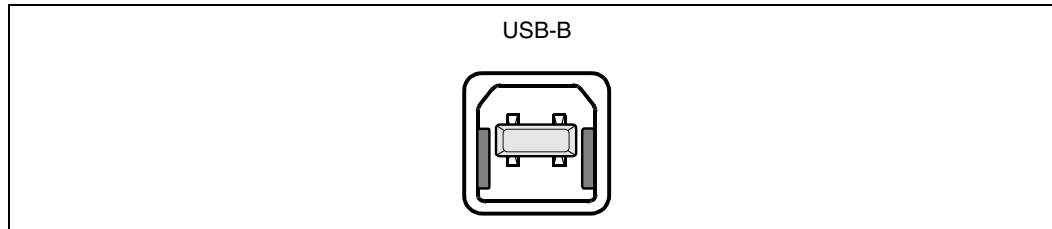

Table 7. USB-B connector pinout: CN3

Pin	Description	Pin	Description	Pin	Description	Pin	Description
1	VBUS	2	DM	3	DP	4	GND

3.2 CAN bus connector

Figure 7. CAN connector 9 pin male D-type: CN1

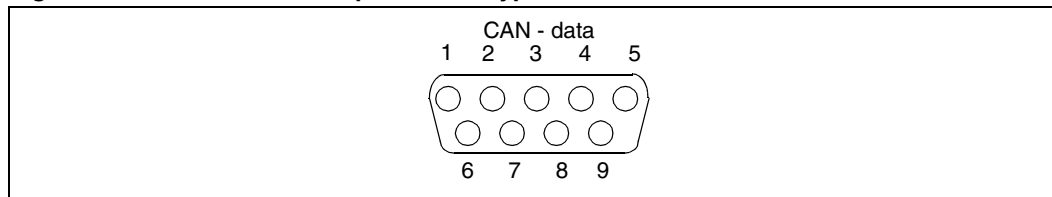

Table 8. CAN connector pinout: CN1

Pin	Description	Pin	Description	Pin	Description
1	Not connected	4	Not connected	7	CAN H, high side bus output
2	CAN L, low side bus output	5	Not connected	8	Pull down to GROUND
3	GROUND	6	GROUND	9	Pull up to +3V3 V

3.3 External analog

Figure 8. External analog connector: CN6

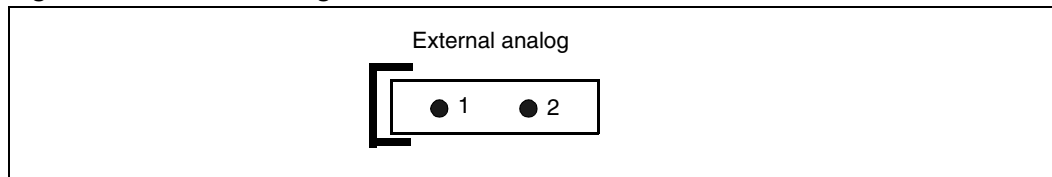

Table 9. External analog connector pinout: CN6

Pin	Description	Pin	Description
1	Analog input	2	Ground

3.4 RS232 serial data connector

9-pin general purpose D-type male connectors

Figure 9. RS232 transmit and receive connectors: CN7, CN8

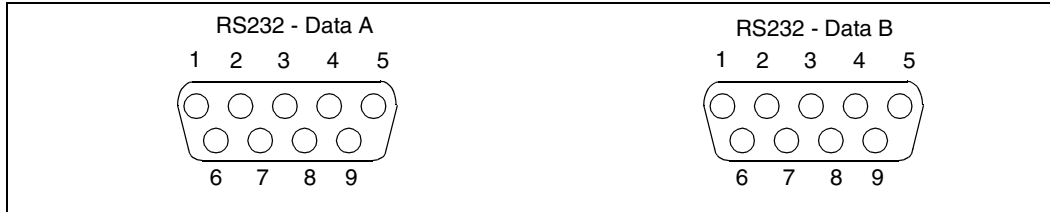

Table 10. RS232 connector pinout: CN7, CN8

Pin	Description	Pin	Description	Pin	Description
1	Shorted to pin 4 and 6	4	Shorted to pin 1 and 6	7	Shorted to pin 8
2	R1IN (port A), R2IN (port B)	5	GROUND	8	Shorted to pin 7
3	T1OUT (port A), T2OUT (port B)	6	Shorted to pin 1 and 4	9	Not connected

3.5 Debug

Figure 10. JTAG standard interface: CN9

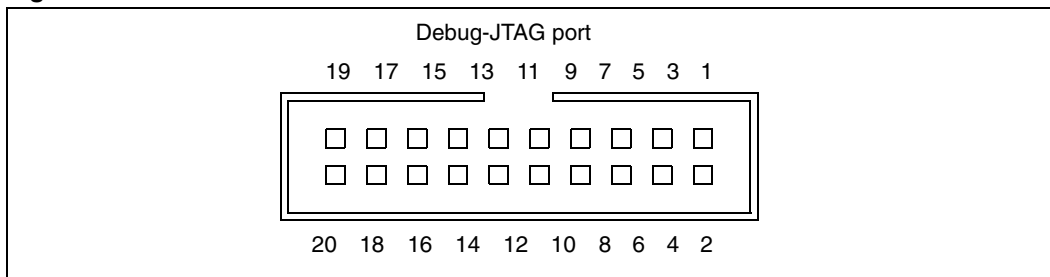

Table 11. JTAG interface pinout: CN9

Pin	Description	Pin	Description
4, 6, 8, 10, 12, 14, 16, 18, 20	GROUND	9	TCK
1	V _{Tref} +3.3 V	11	RTCK (GROUND)
2	V _{supply} +3.3 V	13	TD0
3	notTRST	15	notTRReset
5	TDI	17	DBGRQS pulled down
7	TMS	19	Pulled down

4 Schematics

Figure 11. STR710-EVAL board top level page 1 of 2

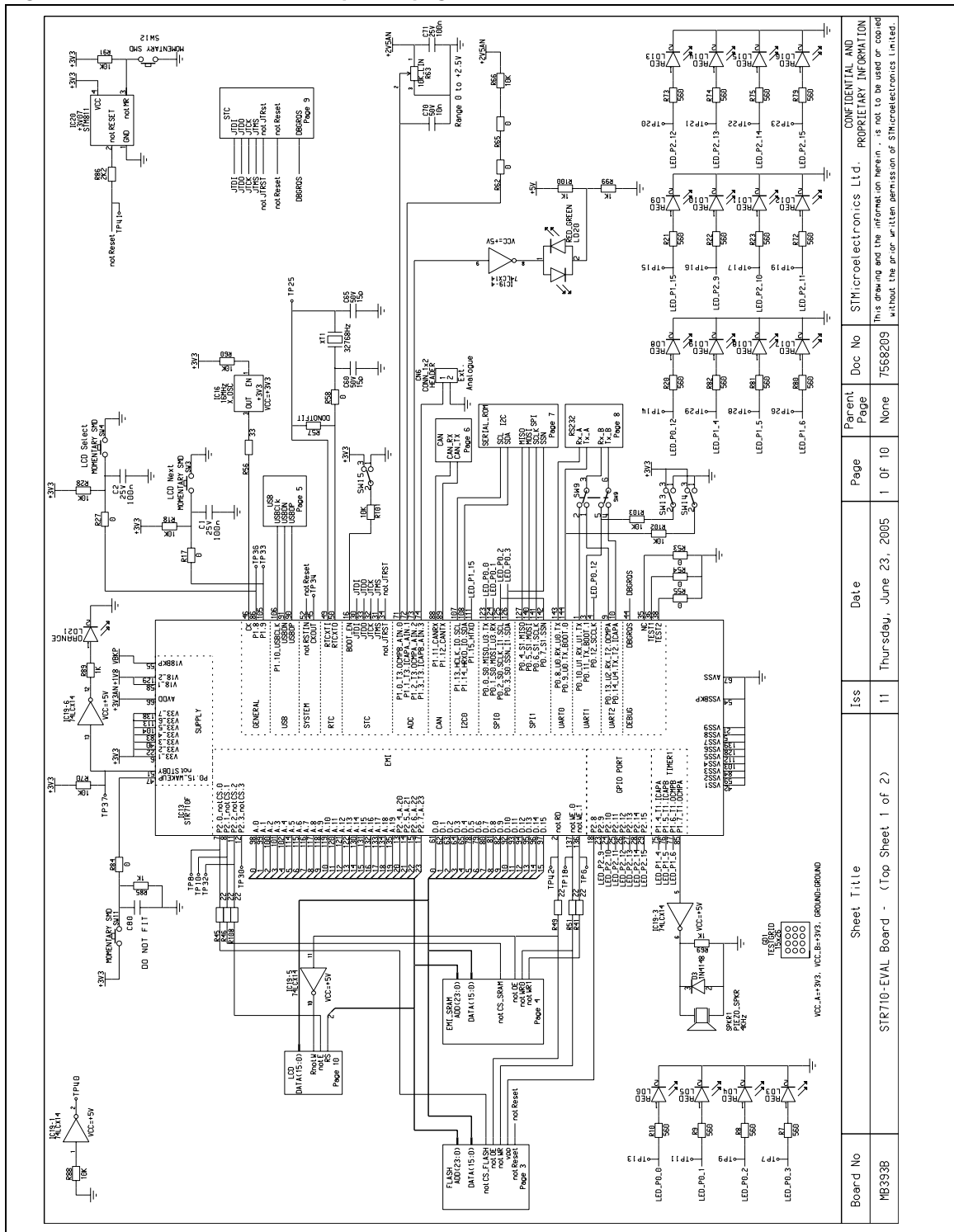

Figure 12. STR710-EVAL board top-level page 2 of 2

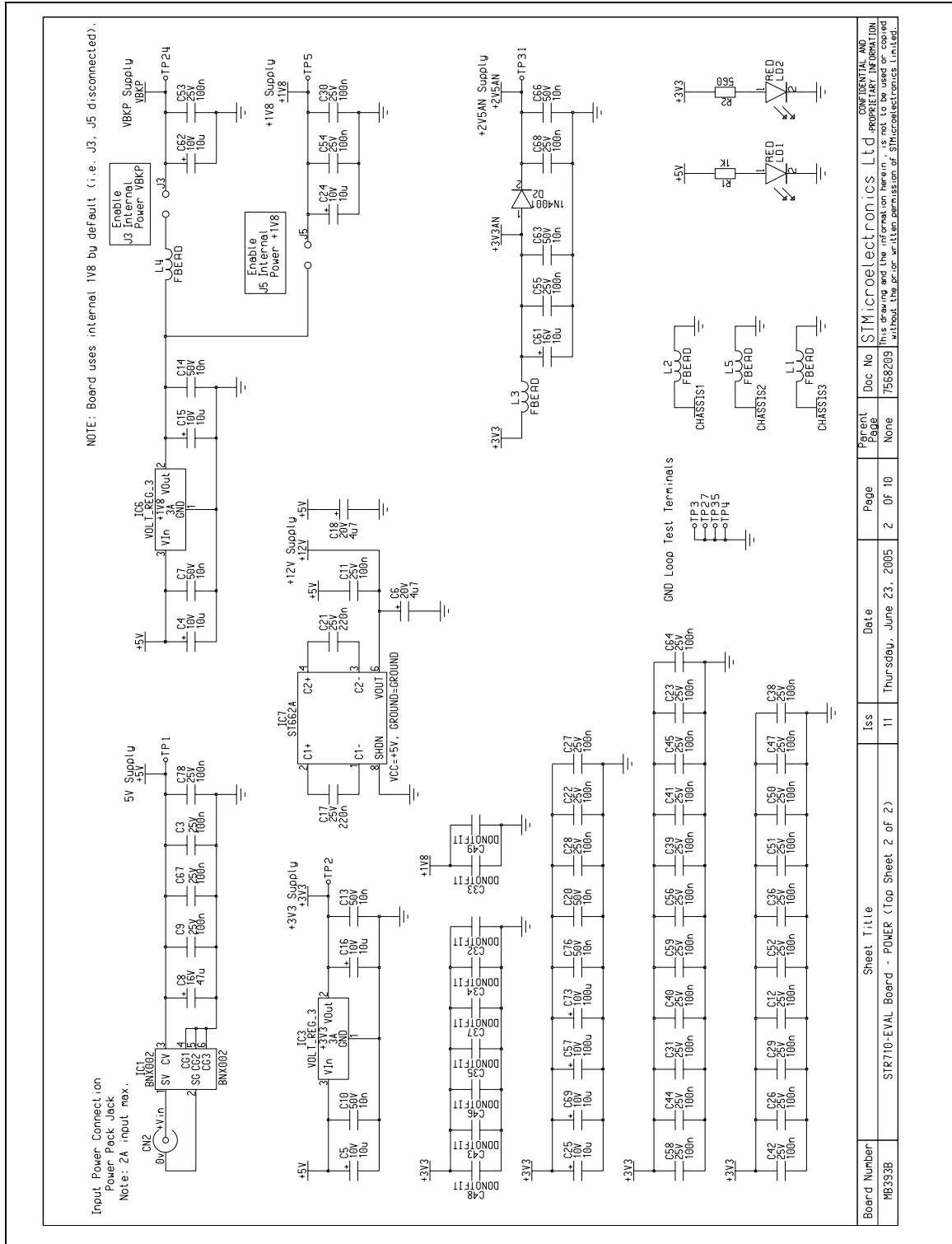

Figure 13. EMI flash

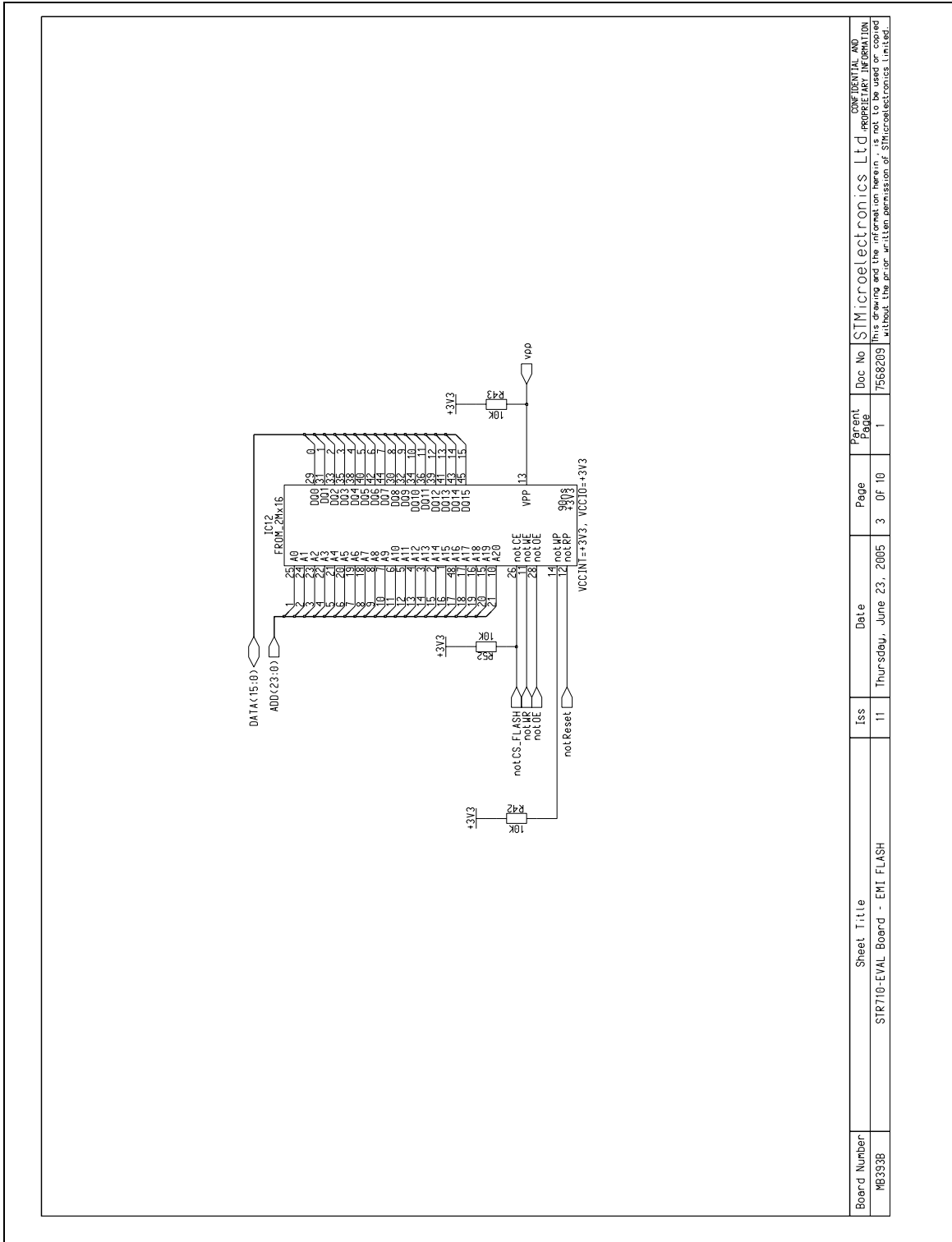
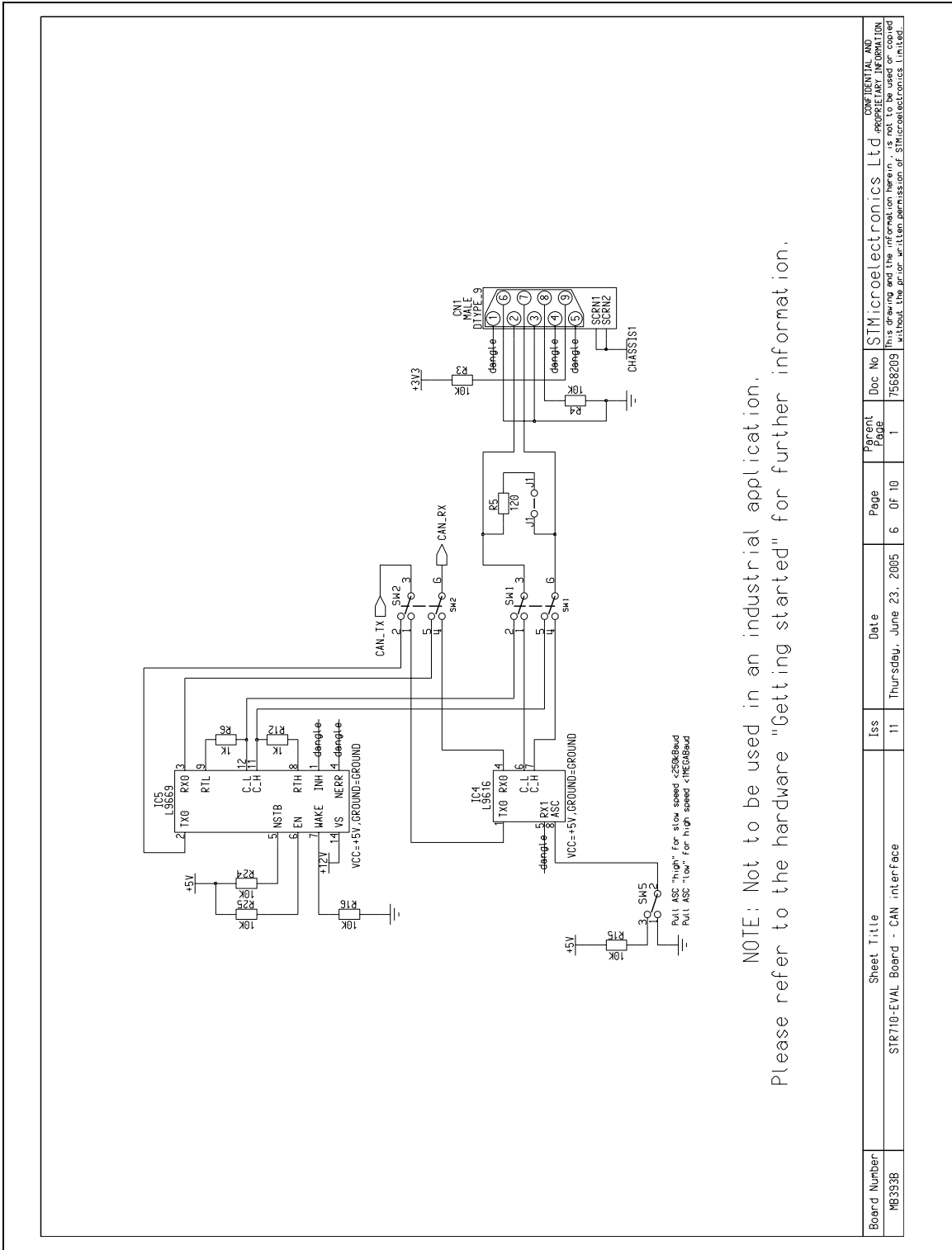

Figure 16. CAN interface



Board Number	Sheet Title	Iss	Date	Page	Parent Page	Doc No	CONFIDENTIAL AND PROPRIETARY INFORMATION
MB353B	STR710-EVAL Board - CAN interface	11	Thursday, June 23, 2005	6 OF 10	1	7568205	This drawing and the information hereon is not to be reproduced or transmitted in any form or by any means, without the prior written permission of STMicroelectronics Limited.

Figure 17. Serial ROM interface

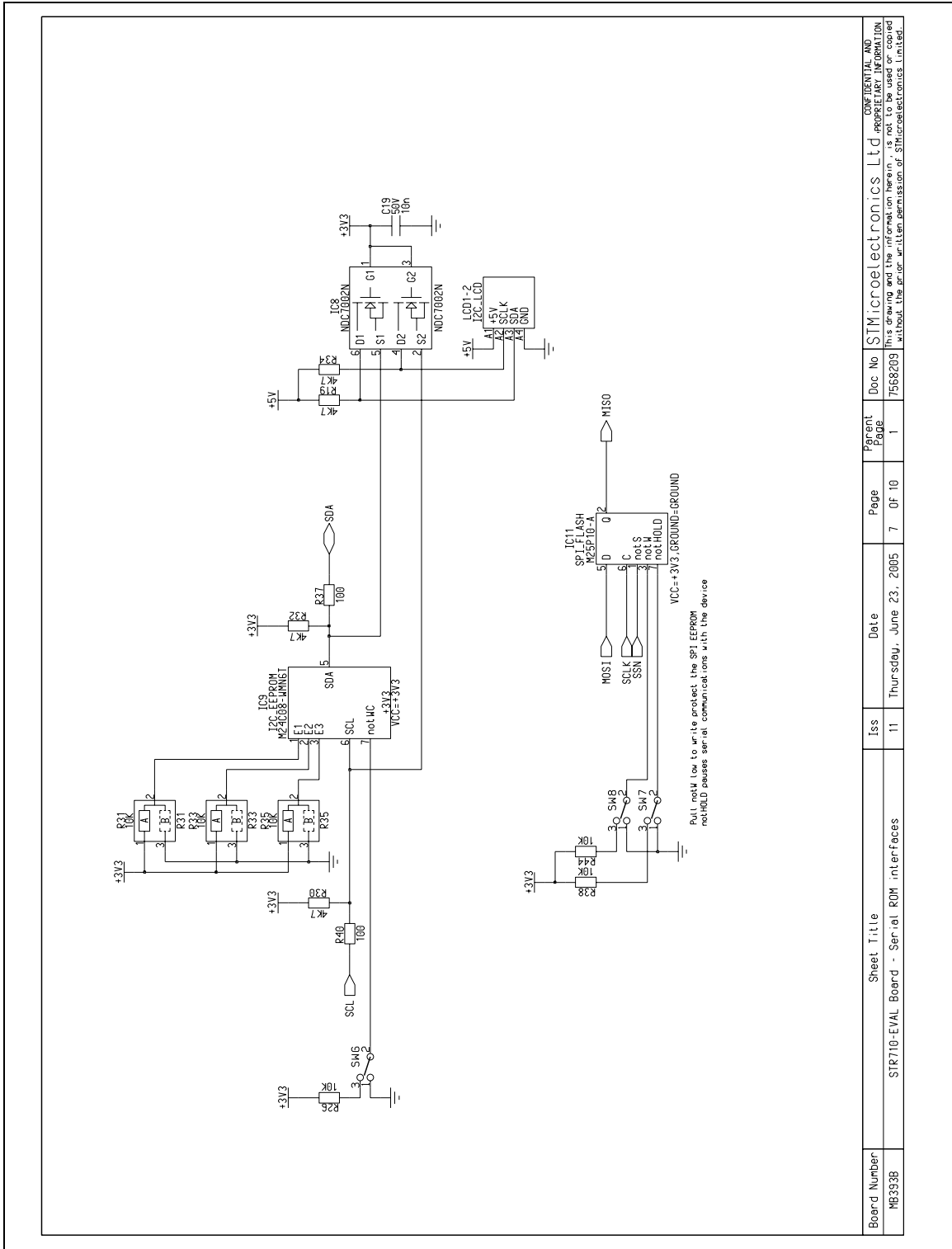
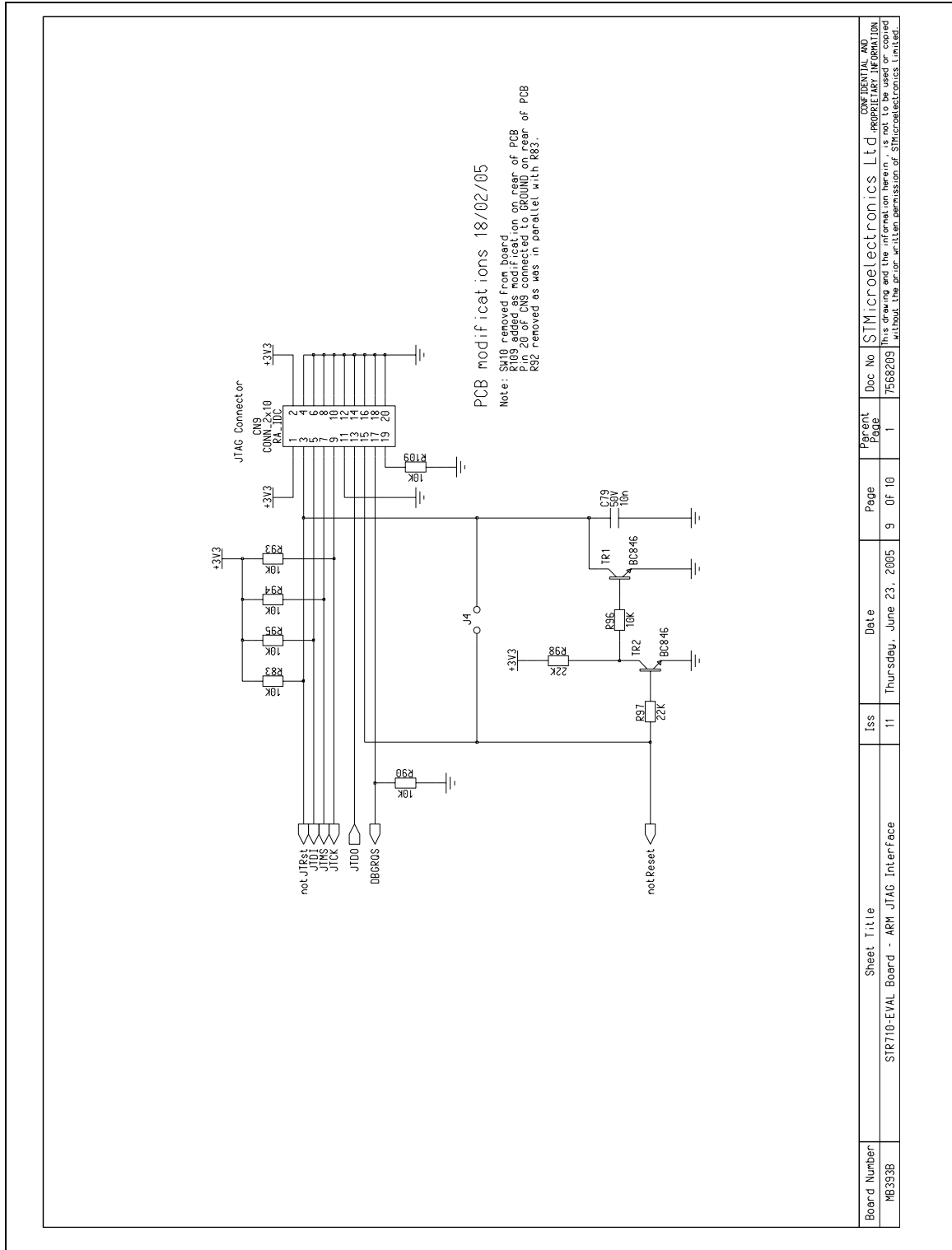

Figure 19. ARM JTAG interface



Board Number	Sheet Title	Iss	Date	Page	Doc No	Present Page
M8393B	STR710-EVAL Board - ARM JTAG Interface	11	Thursday, June 23, 2005	9 Of 10	7568205	1

CONFIDENTIAL AND PROPRIETARY INFORMATION
 This drawing and the information herein is not to be used or copied without the prior written permission of STMicroelectronics Limited.

5 Revision history

Date	Revision	Changes
26-September-2005	1	Initial external release.
4-October-2005	2	<p>Amended Section 2.1 on page 6 to list the JTAG connector CN9.</p> <p>Amended Section 2.8 on page 6 to improve the USB interface description.</p> <p>Amended Section 2.9 on page 7 to improve the CAN interface description.</p> <p>Updated Table 4: Option jumpers on page 10 to show J5 is not fitted.</p> <p>Amended the wording for SW1 in Table 5 on page 10.</p> <p>Amended the first table entry in Table 11 on page 14.</p> <p>Updated Chapter 4: Schematics:</p> <p>Figure 11 on page 15: C80 is now marked as "Do not fit", IC20 reset circuit has a threshold voltage of 3.07 V not 2.63 V.</p> <p>Figure 12 on page 16 J5 marked as "Do not fit".</p> <p>Figure 15 on page 19 IC2 shown with correct connectivity. <i>Note that on the PCB, IC2 is connected with In/Out swapped.</i></p> <p>Figure 19 on page 23, R92 is now removed because it was in parallel with R83.</p> <p>Updated Section 2.9: CAN interface on page 7 to include caution.</p> <p>Updated Chapter 4: Schematics to include the latest revision of schematics.</p> <p>Removed list of third party support vendors from description.</p>

Information furnished is believed to be accurate and reliable. However, STMicroelectronics assumes no responsibility for the consequences of use of such information nor for any infringement of patents or other rights of third parties which may result from its use. No license is granted by implication or otherwise under any patent or patent rights of STMicroelectronics. Specifications mentioned in this publication are subject to change without notice. This publication supersedes and replaces all information previously supplied. STMicroelectronics products are not authorized for use as critical components in life support devices or systems without express written approval of STMicroelectronics.

The ST logo is a registered trademark of STMicroelectronics.
All other names are the property of their respective owners

© 2005 STMicroelectronics - All rights reserved

STMicroelectronics group of companies

Australia - Belgium - Brazil - Canada - China - Czech Republic - Finland - France - Germany - Hong Kong - India - Israel - Italy - Japan -
Malaysia - Malta - Morocco - Singapore - Spain - Sweden - Switzerland - United Kingdom - United States of America

www.st.com

