



# AN2349

## Application note

---

### Simple cost-effective PFC using Bipolar Transistors for low-to-medium power HF Ballasts

---

#### Introduction

This note deals with the implementation of a Power Factor Correction (PFC) in a Discontinuous-mode Boost Converter where a PFC stage is achieved with a power bipolar transistor driven in self oscillating configuration. The new solution proposed exploits the physical relation ( $t_S$ ,  $I_C$ ) of any bipolar transistor to achieve the Pulse Width Modulation (PWM) signal in a Boost Converter.

---

# Contents

<b>1</b>	<b>PFC solutions for low-medium power HF Ballasts</b> .....	<b>5</b>
1.1	Application description .....	6
<b>2</b>	<b>Feedback block</b> .....	<b>9</b>
<b>3</b>	<b>Selection of boost output inductor L1</b> .....	<b>12</b>
3.1	Selection of boost output capacitor C4 .....	13
<b>4</b>	<b>PFC driving network</b> .....	<b>16</b>
4.1	Feed-Back block .....	22
<b>5</b>	<b>T Transformer and L1 inductor specifications</b> .....	<b>23</b>
5.1	220V design .....	23
5.2	120V design .....	23
<b>6</b>	<b>Revision history</b> .....	<b>29</b>

## List of tables

Table 1.	40W Demoboard 220V bill of materials .....	25
Table 2.	40W Demoboard 120V bill of materials .....	27
Table 3.	Document revision history .....	29

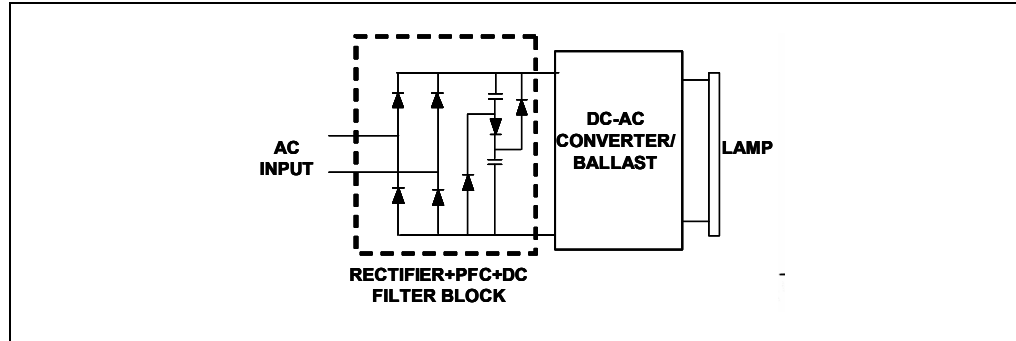
## List of figures

Figure 1.	Valley Fill circuit schematic diagram . . . . .	5
Figure 2.	Valley Fill input current waveform . . . . .	5
Figure 3.	Active PFC with IC and MOSFET in boost topology. . . . .	6
Figure 4.	Base schematic of Bipolar PFC in HF ballast voltage Fed . . . . .	6
Figure 5.	Ts modulation in bipolar PFC . . . . .	7
Figure 6.	I <sub>main</sub> achieved using the basic Bipolar PFC shown in <i>Figure 4</i> . . . . .	7
Figure 7.	Detail of storage time value and I <sub>c</sub> in t <sub>2</sub> instant . . . . .	8
Figure 8.	Detail of storage time value and I <sub>c</sub> in t <sub>1</sub> instant . . . . .	8
Figure 9.	Complete electrical schematic of the Bipolar PFC in HF Ballast . . . . .	9
Figure 10.	PFC stage . . . . .	9
Figure 11.	Feed-back block . . . . .	9
Figure 12.	PFC waveforms with Feedback block working . . . . .	10
Figure 13.	I <sub>main</sub> achieved by the proposed bipolar PFC solution . . . . .	10
Figure 14.	Detail of Storage time value in t <sub>2</sub> . . . . .	11
Figure 15.	Detail of storage time value in t <sub>1</sub> . . . . .	11
Figure 16.	Pre-heating @ 220V . . . . .	11
Figure 17.	Current on the electrolytic capacitor . . . . .	14
Figure 18.	Inductor current with di/dt>0 and transformer voltage shape . . . . .	16
Figure 19.	Inductor current with di/dt=0 and transformer voltage shape . . . . .	16
Figure 20.	Inductor current with di/dt<0 and transformer voltage shape . . . . .	17
Figure 21.	Transformer V <sub>out</sub> shape and base current shape . . . . .	17
Figure 22.	Collector current and base current shape . . . . .	19
Figure 23.	Detail of T1 total charge during T <sub>on</sub> . . . . .	20
Figure 24.	40W demoboard electrical schematic . . . . .	24
Figure 25.	40W demoboard PCB layout and mounting components . . . . .	25

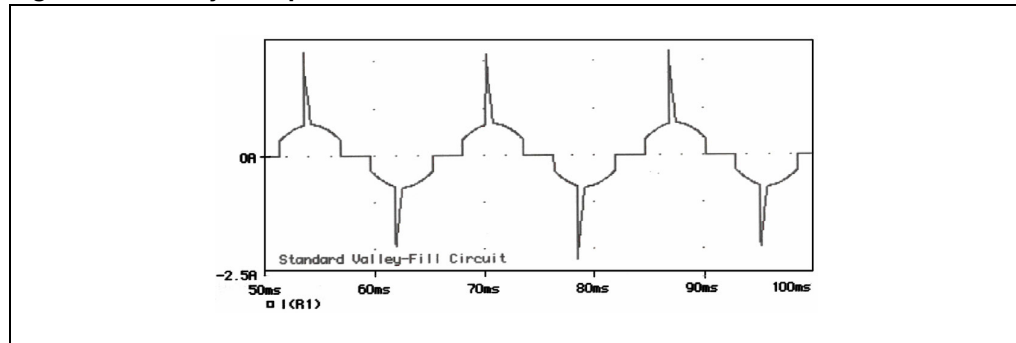
# 1 PFC solutions for low-medium power HF Ballasts

The Valley Fill circuit is an example of a low-cost passive PFC available on the market.

**Figure 1. Valley Fill circuit schematic diagram**

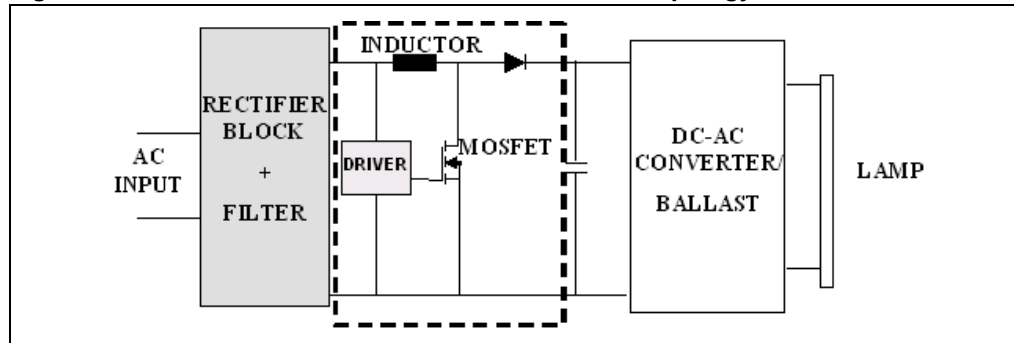


**Figure 2. Valley Fill input current waveform**



The capacitors are charged in serie, and discharged, via the two diodes, in parallel. Current is drawn from the line from 30° to 150°, and then from 210° to 330°. Discontinuities occur from 150° to 210° and from 330° to 360°, and then the cycle repeats itself.

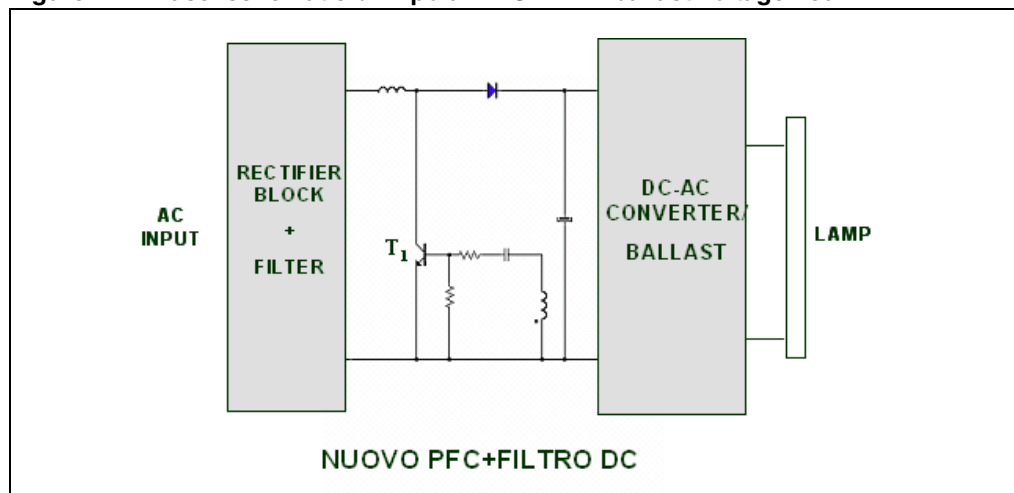
Disadvantages of this PFC solution are spikes on input current waveform and large zero current gaps between the half sinusoidal wave and the next one (meaning a lower power factor and high input current distortion), and high ripple in the DC output voltage that causes poor performance in High Power Lamps. On the other hand, high performances can be achieved by IC driver optimized for controlling PFC regulators in boost topology as shown in [Figure 3](#).

**Figure 3. Active PFC with IC and MOSFET in boost topology**

The proposed Bipolar PFC solution targets the low-cost HF Ballast market up to 80 W as it provides a simple cost-effective solution without sacrificing THD and PF levels. It does not need any ICs to achieve the PWM signal since it uses just a power bipolar transistor and a closed-loop feedback that performs the duty cycle modulation and a satisfactory output power regulation.

## 1.1 Application description

The active PFC solution with Bipolar transistor adopts the Boost topology working in Discontinuous Conduction mode. This is the most simple and cost-effective solution for 220V and 120V mains and low\medium power.

**Figure 4. Base schematic of Bipolar PFC in HF ballast voltage Fed**

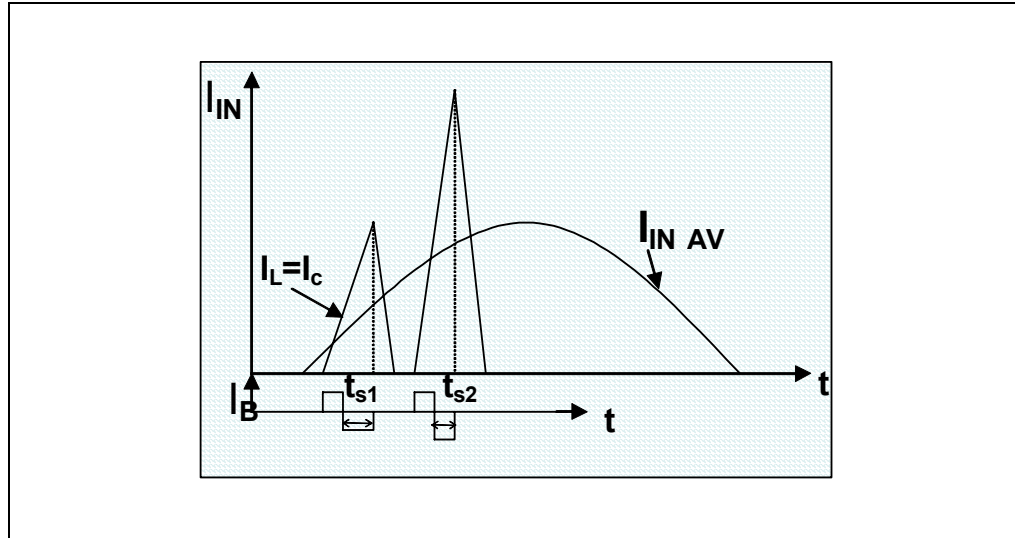
No IC is used to generate a PWM signal, but the physical relation ( $t_s$ ,  $I_C$ ) of any power bipolar transistor is exploited when the base current  $I_B$  value is kept constant.

*Figure 5* shows two different storage time values at two different input  $V_{AC}$  values: in  $t_1$  the bipolar reaches a higher saturation level than in  $t_2$ , and this means  $t_{s1} > t_{s2}$ .

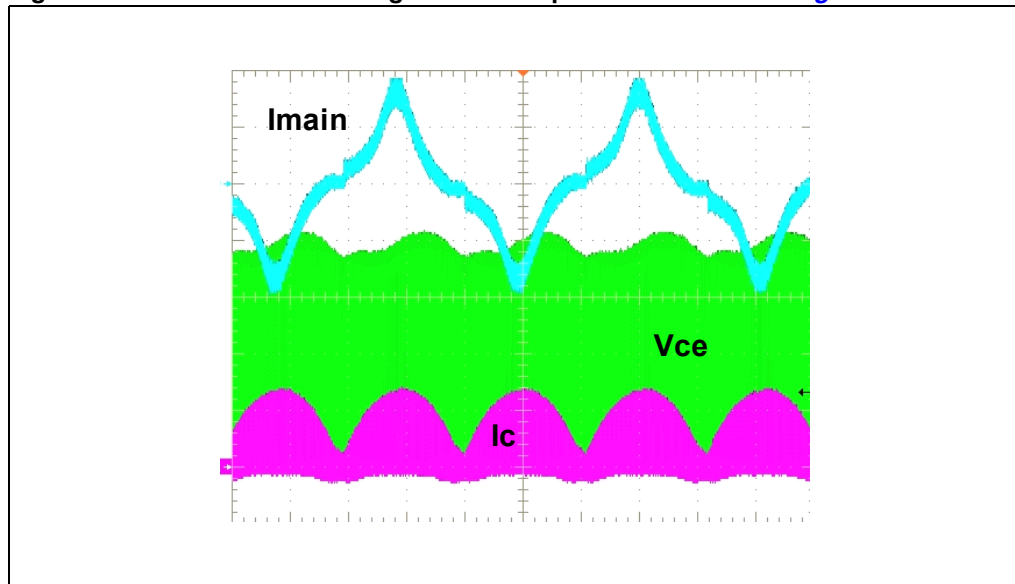
The overall switch on time is given by the sum of " $I_{BON}$  time" plus the storage time, therefore, if the " $I_{BON}$  time" is constant, the duty cycle changes according to the  $t_s$  modulation. This natural duty cycle variation generates an appropriate PWM signal to

control the PFC stage and reduces the  $I_{main}$  distortion achieving a THD in the range of about 30%, with a shape of the current drawn from the main as shown in [Figure 6](#).

**Figure 5.  $T_s$  modulation in bipolar PFC**



**Figure 6.  $I_{main}$  achieved using the basic Bipolar PFC shown in [Figure 4](#)**



[Figure 7](#) and [Figure 8](#) show in a real situation, what has been explained before.

Figure 7. Detail of storage time value and  $I_c$  in  $t_2$  instant

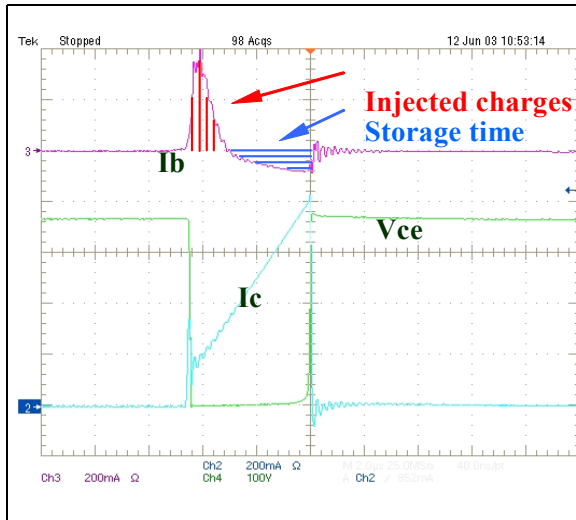
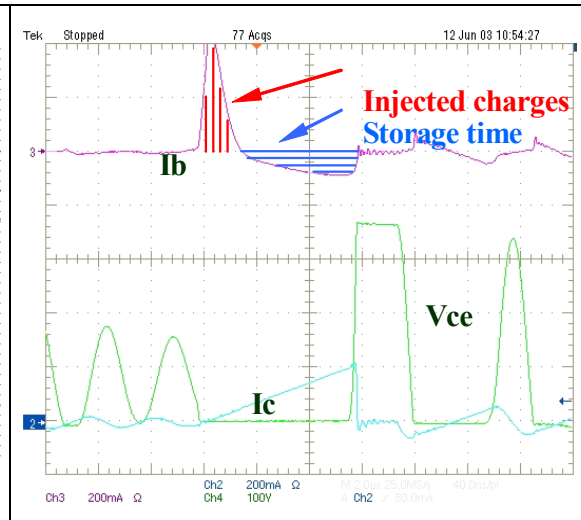


Figure 8. Detail of storage time value and  $I_c$  in  $t_1$  instant



The PWM signal acts on  $T_1$  bipolar transistor base through an auxiliary winding T on the transformer normally used in the ballast.

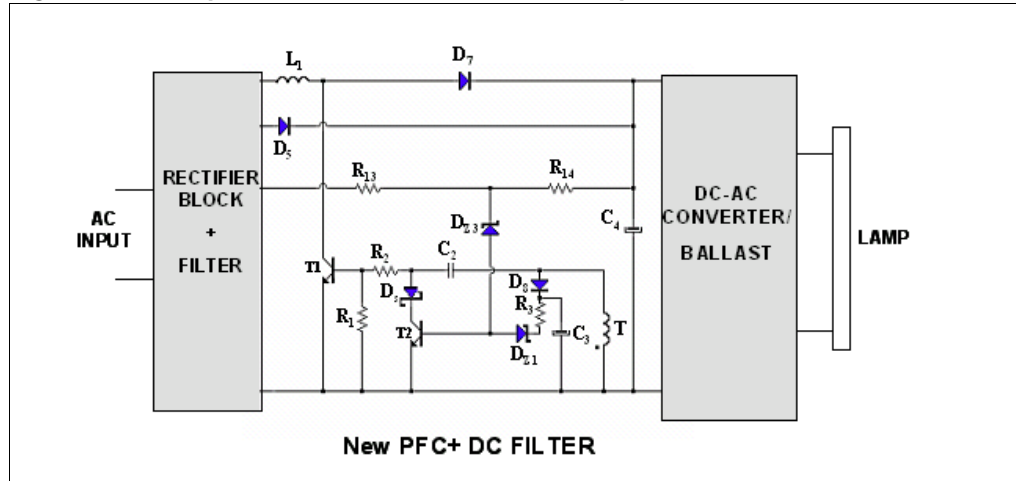


## 2 Feedback block

The duty cycle modulation performed by the Basic Solution shown in [Figure 4](#) is not enough effective to achieve high THD values and no protection task can be implemented against overload or high VAC values.

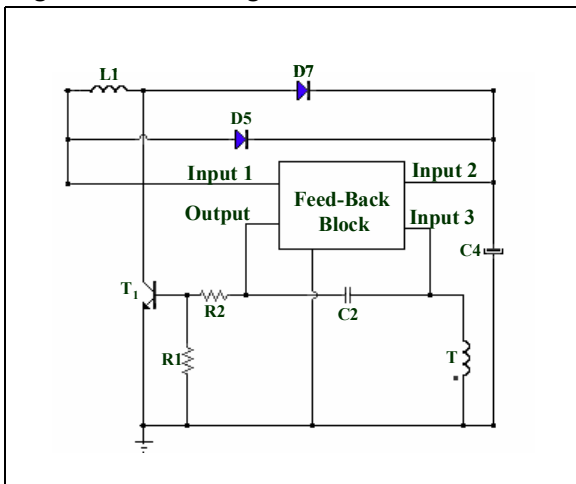
A negative feedback network has been introduced to further control the duty cycle modulation by modifying the total  $Q_{on}$  charge which is injected into the T1 base. [Chapter Figure 9. on page 9](#) shows the complete solution of the proposed PFC stage.

**Figure 9. Complete electrical schematic of the Bipolar PFC in HF Ballast**

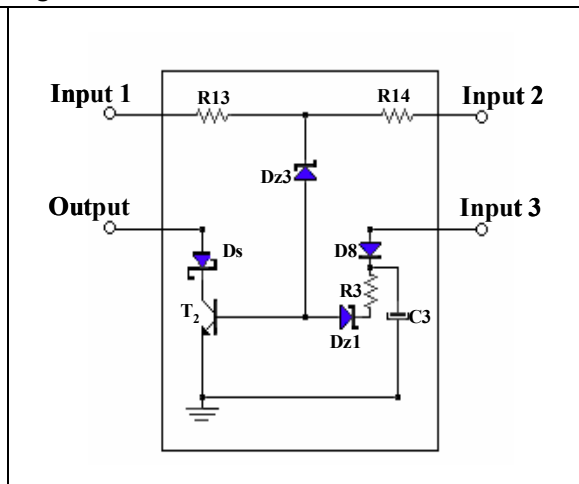


The feed-back block in [Figure 11](#) changes the  $T_1$   $Q_{ON}$  charge by modifying both the  $I_{BON}$  amplitude and duration through the intervention of the transistor  $T_2$ . In particular the proposed network by the  $T_2$  conduction reduces the base current permitting to reduce the duty cycle of the main switch ( $T_1$ ) performing a further THD correction and output power regulation.

**Figure 10. PFC stage**



**Figure 11. Feed-back block**



The network  $D_8$ ,  $R_3$ ,  $D_{Z1}$ , and  $C_3$  in *Figure 11* ensures the switch protection during start-up thanks to a smart combination of three input signals.

1. Input 1 comes from the Main Voltage and it's used to limit the amount of the distortion improving the THD.
2. Input 2 comes from PFC Vout : it's used to further regulate the power factor and to regulate the PFC Vout against supply voltage variations.
3. Input 3 signal is a voltage proportional to the pre-heating current during start up and it is used. to protect the power switch against over voltage . The Output signal is the base current driving the  $T_1$  main switch.

The transistor  $T_2$  during its On-state modifies the natural modulation imposed by the storage time variation of the transistor  $T_1$  since:

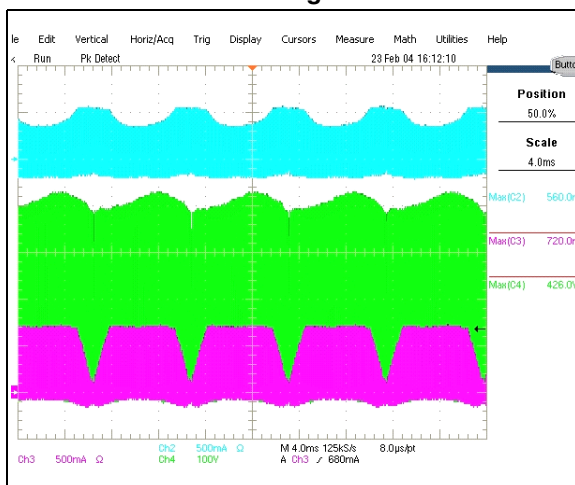
- It reduces the time constant during the charge of the capacitor  $C_2$  thus reducing the time length of the On base current of  $T_1$
- It shunts part of the same current to ground thus reducing its amplitude.

The combination of the previous two effects implies a reduction of the duty cycle of the transistor  $T_1$  helping to correct the THD and the power factor level .

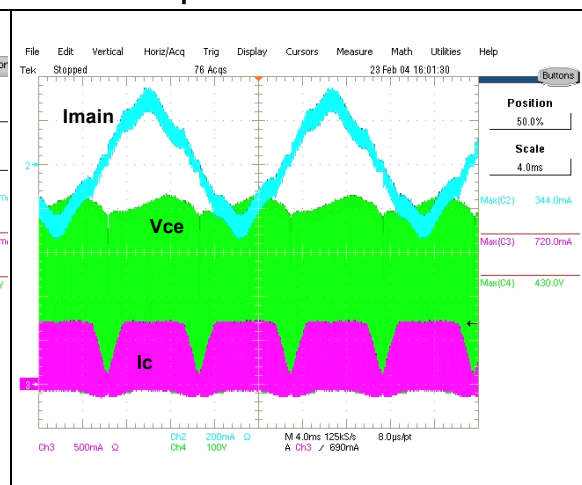
The schottky diode  $D_s$  in series with the collector of the transistor  $T_2$  by blocking any reverse current on the transistor itself ensures a low voltage drop during  $T_2$  on state.

The steady state waveforms associated to the new proposed circuit are below reported in *Figure 16*.

**Figure 12. PFC waveforms with Feedback block working**



**Figure 13. I<sub>main</sub> achieved by the proposed bipolar PFC solution**

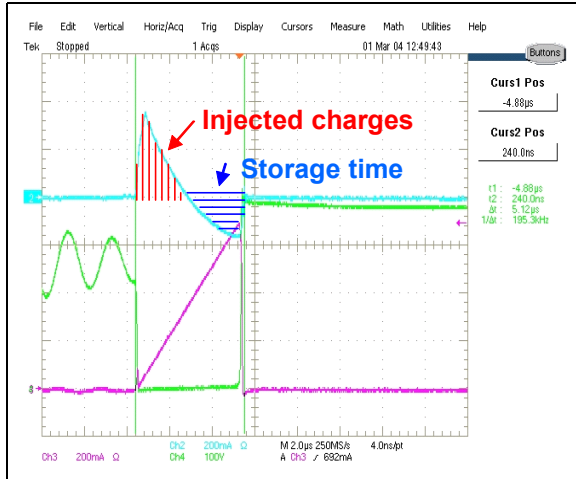


Components values of the Feedback block have been chosen to achieve a base current modulation that allows obtaining a constant collector current in the range of  $V_{Msen}$  at with  $30^\circ \leq \alpha \leq 150^\circ$ .

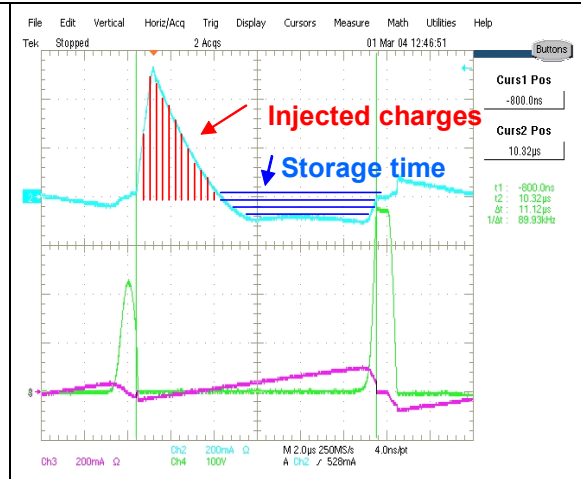
Waveforms reported in *Figure 13* shows now a quasi-sinusoidal behavior of the current drawn from the main, while the blue waveform in *Figure 12* shows the  $T_1$   $I_{BON}$  modulation performed by the negative feedback.

The overall storage time modulation achieved by the Bipolar PFC working with the negative feedback network is evident in *Figure 14* and *Figure 15* showing real values of storage time detected on the oscilloscope at  $t_1$  and  $t_2$  instances.

**Figure 14. Detail of Storage time value in  $t_2$**

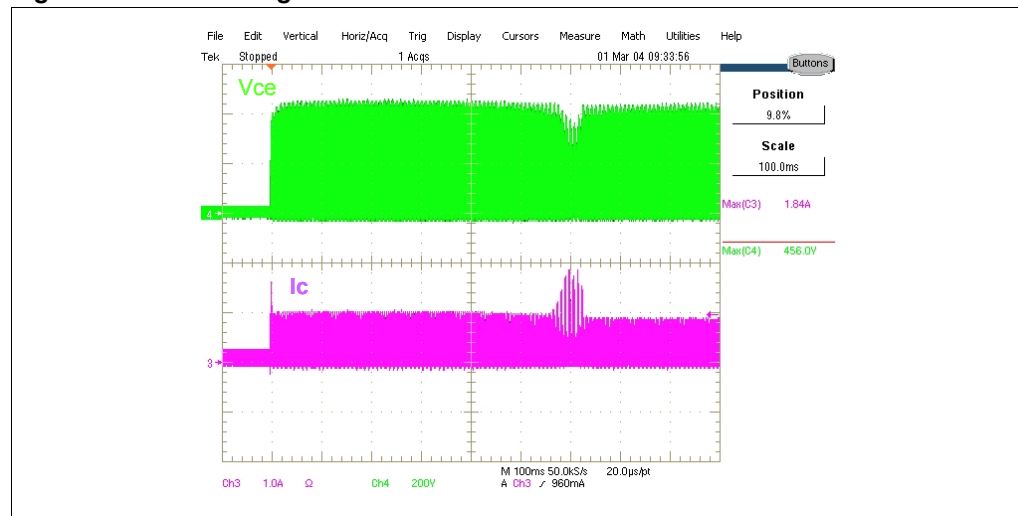


**Figure 15. Detail of storage time value in  $t_1$**



*Figure 16* shows the pre-heating and start-up phase waveforms.

**Figure 16. Pre-heating @ 220V**



### 3 Selection of boost output inductor L<sub>1</sub>

The boost output inductor L<sub>1</sub> is calculated in the peak of sinusoidal voltage at maximum instantaneous input power in order to obtain the minimum I<sub>P</sub> value assuring the discontinuous mode operation. This calculation is made considering a working operation at constant current peak I<sub>P</sub> due to the base current modulation, and fixing a working switching frequency. Supposed a purely resistive load it is:

#### Equation 1

$$P = V_{\text{eff}} \cdot I_{\text{eff}} = \frac{(V_M \cdot I_M)}{2}$$

where V<sub>M</sub> is the maximum input main voltage and I<sub>M</sub> is the maximum input main current.

Then from [Equation 1](#),

#### Equation 2

$$V_M \cdot I_M = 2P$$

Now considered the total energy stored by the inductor in the period at the maximum input main voltage:

#### Equation 3

$$E_{\text{TOT}} = 2PT = \frac{2P}{f_{\text{sw}}}$$

where T is the period and f<sub>sw</sub> is the working switching frequency.

But the total energy stored by the inductor in the period is, also, the sum of two contributes, the first LI<sup>2</sup><sub>P</sub>/2, due to the inductor L<sub>1</sub> charge and the other one, V<sub>M</sub>I<sub>P</sub>t<sub>B</sub>/2, due to the discharge of the same via the main voltage, then equalizing the two terms we obtain:

#### Equation 4

$$\frac{2P}{f_{\text{sw}}} = \frac{LI_P^2}{2} + \frac{V_M \cdot I_P t_B}{2}$$

where I<sub>P</sub> is the peak of the working switching current at maximum voltage V<sub>M</sub> and t<sub>B</sub> is the inductor discharge time that is:

#### Equation 5

$$t_B = \frac{LI_P}{V_{\text{out}} - V_M}$$

with V<sub>out</sub> imposed at 390V and it is the PFC output voltage.

Substituting t<sub>B</sub> in [Equation 4](#):

#### Equation 6

$$\frac{2P}{f_{\text{sw}}} = \frac{LI_P^2}{2} + \left[ \left( \frac{V_M \cdot I_P}{2} \right) \cdot \left( \frac{LI_P}{V_{\text{out}} - V_M} \right) \right] = \frac{LI_P^2}{2} \left( \frac{V_{\text{out}}}{V_{\text{out}} - V_M} \right)$$

calculated in the max point of the sinusoid, in general for 30° ≤ α ≤ 150° it can be can written:

**Equation 7**

$$\frac{2P(t)}{f_{SW}} = \frac{LI_P^2}{2} + \left[ \left( \frac{V_M \sin \alpha t \cdot I_P}{2} \right) \cdot \left( \frac{LI_P}{V_{out} - V_M \sin \alpha t} \right) \right] = \frac{LI_P^2}{2} \cdot \left( \frac{V_{out}}{V_{out} - V_M \sin \alpha t} \right)$$

where according to the working operation,  $LI_P^2/2$  is the constant term, while the other one contains the sinusoidal modulation of the main current with  $30^\circ < \alpha t < 150^\circ$ .

In order to calculate  $I_P$  you consider the instantaneous Max Power in a 50 Hz period:

**Equation 8**

$$P_M = V_M \cdot I_M$$

but  $I_M$  is also the medium value of the peak of the working switching current in the period  $T$  corresponding to the max point of the Main Voltage  $V_M$ .

**Equation 9**

$$I_M = I_P \cdot \frac{t_A + t_B}{2T}$$

where  $t_A = LI_P/V_M$  is the  $L_1$  charge time and  $t_B = LI_P/V_{out} - V_M$  is the  $L_1$  discharge time.

Now from [Equation 9](#):

**Equation 10**

$$I_P = I_M \cdot \frac{2T}{t_A + t_B}$$

Substituting [Equation 10](#) in [Equation 7](#) and resolving by  $L$ :

**Equation 11**

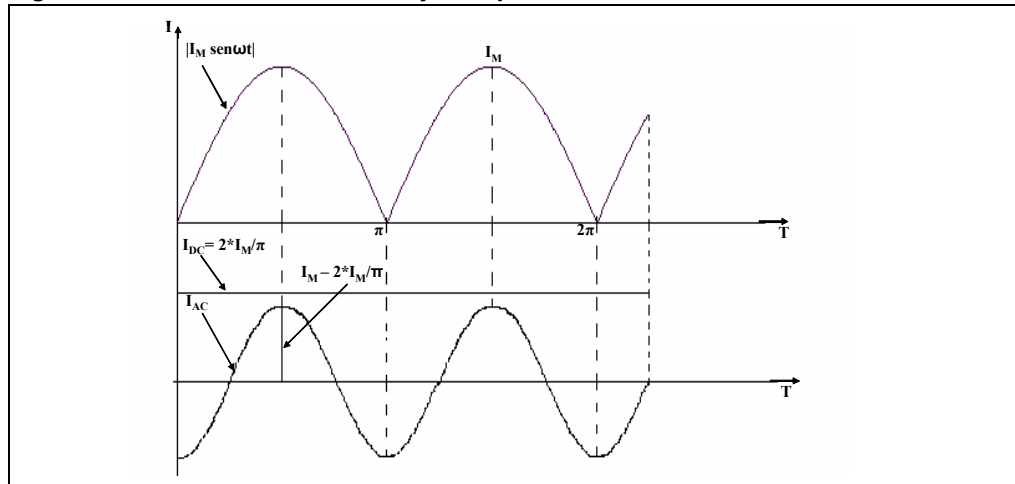
$$L = \frac{P}{f} \cdot \left( \frac{t_A + t_B}{T} \right)^2 \cdot \left( \frac{1}{I_M^2} \right) \cdot \left( \frac{V_{out} - V_M}{V_{out}} \right)$$

where  $t_A + t_B/T$  is chosen equal to 0.70 in order to ensure that the circuit remains in the discontinuous mode leaving a dead-time of 0.3T.

### 3.1 Selection of boost output capacitor C4

The PFC works to obtain a sinusoidal Main Current. Therefore the capacitor C4 will charge with a rectified current at double half-wave shape, as shown in [Figure 17](#). This current shape will generate on the electrolytic capacitor an almost continuous voltage with a ripple value depending on the same capacitor value. In order to calculate the capacitor C4, the current flowing on the electrolytic capacitor can be assumed as thoroughly the sum of two contributions, one due to a continuous component and other one due to an alternate component, as shown in [Figure 17](#). The alternate component will have double frequency respect to the main frequency.

Figure 17. Current on the electrolytic capacitor



Thus for  $0 < \omega t < \pi$ :

**Equation 12**

$$|I_M \sin \alpha t| \cong I_{DC} + I_{AC}$$

where  $I_{DC}$ , the continuous component, is the mean value of  $|I_M \sin \alpha t|$  :

**Equation 13**

$$I_{DC} = \int_0^{\pi} \frac{I_M}{\pi} \sin \alpha t \cdot dt = \frac{2I_M}{\pi}$$

and  $I_{AC}$  is the alternate component with double frequency and out of phase of  $\pi/2$  respect to the main one that is:

**Equation 14**

$$I_{AC} = \left( I_M - \frac{2I_M}{\pi} \right) \sin \left( -2\alpha t - \frac{\pi}{2} \right)$$

Now substituting [Equation 13](#) and [Equation 14](#) into [Equation 12](#), we have:

**Equation 15**

$$|I_M \sin \alpha t| \cong \frac{2I_M}{\pi} + \left( I_M - \frac{2I_M}{\pi} \right) \sin \left( -2\alpha t - \frac{\pi}{2} \right)$$

The peak ripple voltage  $V_{M_{RIPPLE}}$  is:

**Equation 16**

$$V_{M_{RIPPLE}} = \frac{V_{PP_{RIPPLE}}}{2}$$

But  $V_{M_{RIPPLE}}$  is the alternate voltage on the capacitor due to the  $I_{AC}$

**Equation 17**

$$V_{M_{RIPPLE}} = \left( I_M - \frac{2I_M}{\pi} \right) \cdot X_C$$

where from [Equation 17](#), the  $I_M - 2I_M/\pi$  is the max amplitude of the alternate current  $I_{AC}$  on the electrolytic capacitor, while  $X_C$  is the capacitive reactance  $X_C = \omega C_{OUT} = 2\pi f^*$  of the electrolytic capacitor, with  $f^* = 2f_{main}$  ( $f_{main} = 50/60\text{Hz}$ ).

Equalizing [Equation 16](#) and [Equation 17](#) you have

**Equation 18**

$$\frac{V_{PP\_RIPPLE}}{2} = \left( I_M - \frac{2I_M}{\pi} \right) \cdot 2\pi f C_{OUT}$$

and resolving by C:

**Equation 19**

$$C_{OUT} = \frac{V_{PP\_RIPPLE}}{4\pi f} \cdot \frac{1}{I_M}$$

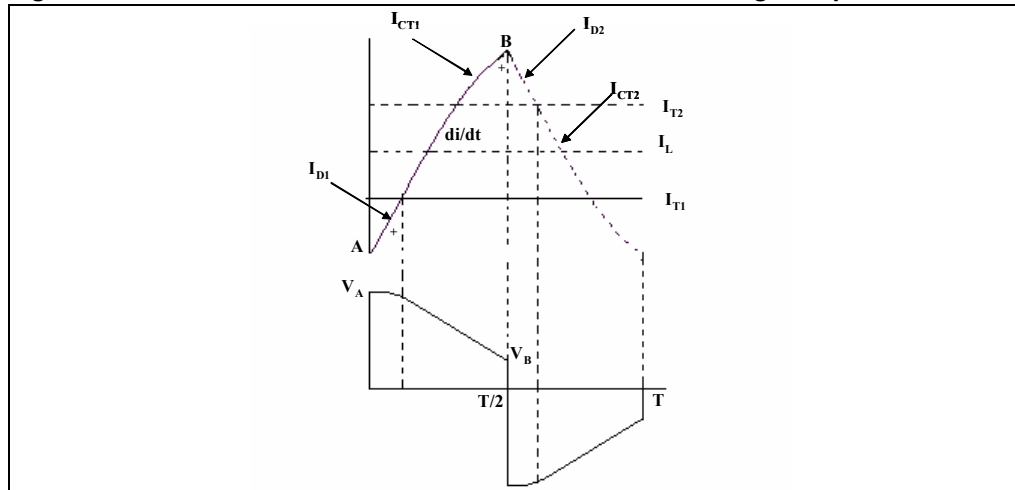
where  $V_{PP\_RIPPLE} = V_{DC\_OUT\_MAX} - V_{DC\_OUT\_MIN}$  is the peak to peak ripple voltage and from [Equation 2](#)  $I_M = 2 \cdot P / V_M$ .

## 4 PFC driving network

The network composed by the capacitor and resistor in series to the base of the power bipolar transistor T1 are chosen in order to fix the duty-cycle at level less than 50% in the max point of the main sinusoid and they determine the conduction time of the device, while the base-emitter resistor has the function to regulate the capacitor discharge during the off state of the device and to define the duty-cycle. The bipolar transistor used as switching is driven in a self-oscillating configuration taking the signal in order to polarize its base through an auxiliary winding on the transformer normally used in the ballast. This signal can assume three different shapes depending on the signal shape on the ballast due to the  $di/dt$  variation of the Ballast inductor current. The inductor current is the sum of the Transistor Collector Current, Diode Current and Snubber Capacitor Current.

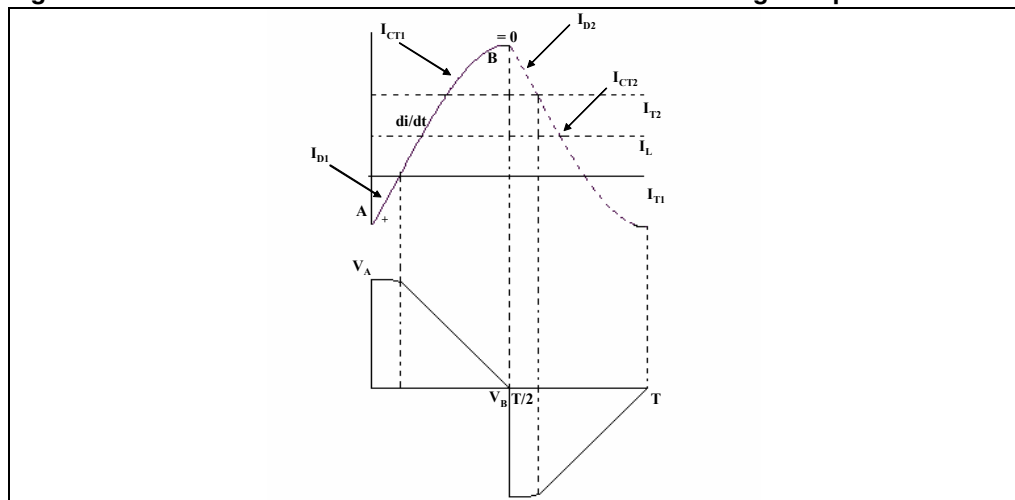
1. End collector current with  $di/dt > 0$

**Figure 18. Inductor current with  $di/dt > 0$  and transformer voltage shape**



2. End collector current with  $di/dt = 0$

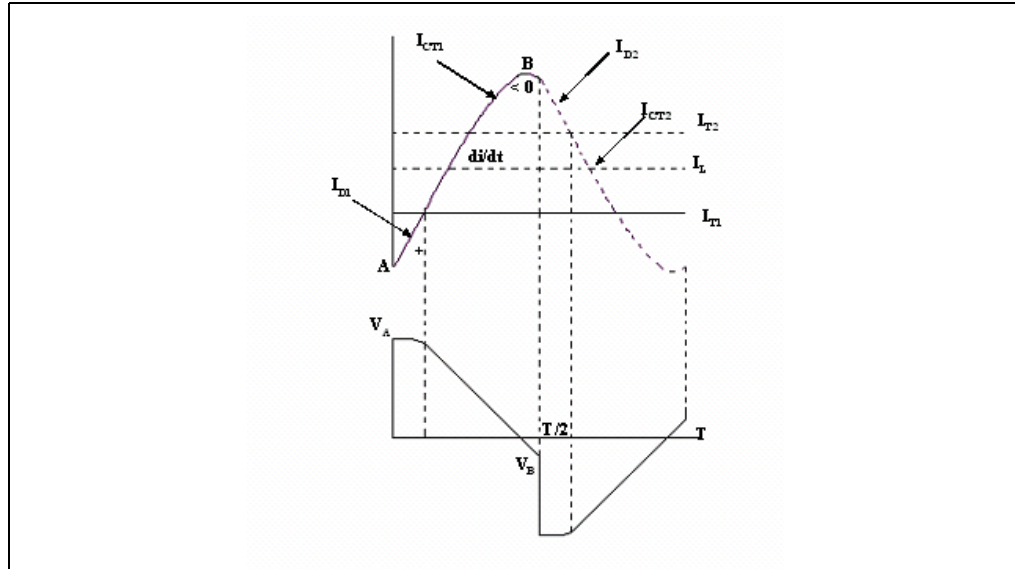
**Figure 19. Inductor current with  $di/dt = 0$  and transformer voltage shape**





3. End collector current with  $di/dt < 0$

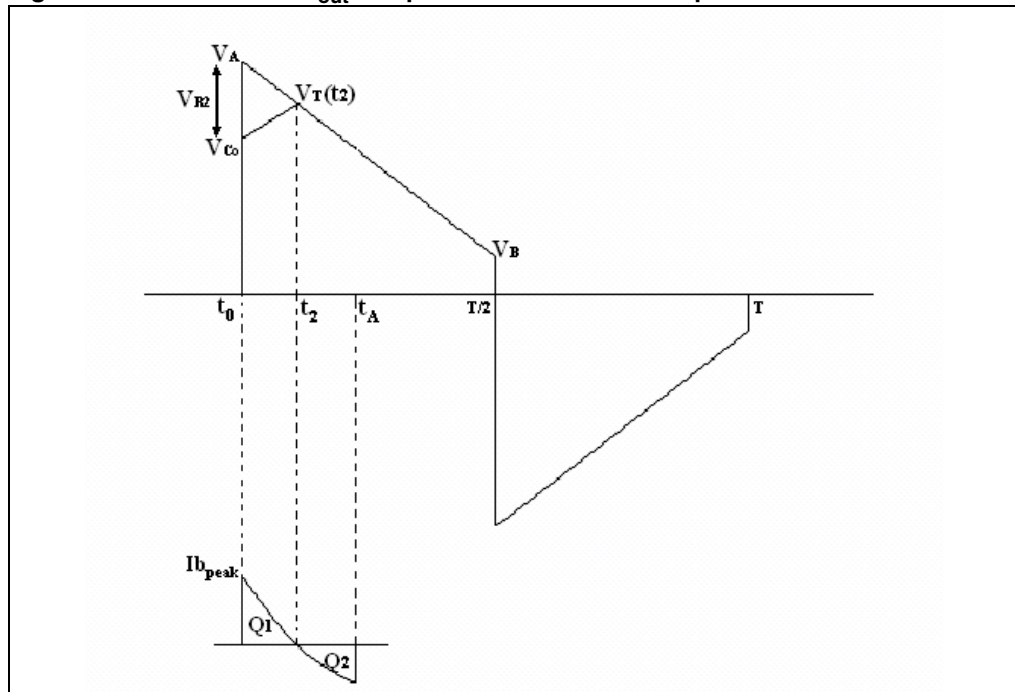
**Figure 20. Inductor current with  $di/dt < 0$  and transformer voltage shape**



The first condition is considered for our reference design,  $di/dt > 0$ , and in particular the slope on the point A has a  $di/dt$  value four times larger than the slope of the point B.

Figure 21 shows the output voltage of the transformer where the  $V_A$  value is four times larger than the  $V_B$  value.

**Figure 21. Transformer  $V_{out}$  shape and base current shape**



The output voltage  $V_T$  of the transformer at the initial instant is:

**Equation 20**

$$V_{T_0} = V_{C_0} + V_{R_2} + V_{BE} = V_A$$

where  $V_{C_0} = 2.5V$  is the initial capacitor voltage,  $V_{R_2}$  is the resistor  $R_2$  voltage and  $V_{BE}$  is the  $T_1$  BE voltage.

The shape of the transformer voltage in a half period  $T/2$  is:

**Equation 21**

$$V_T(t) = V_A - \frac{(V_A - V_B) \cdot t}{\frac{T}{2}}$$

After the initial instant, the capacitor begins to charge and, as soon as  $V_C(t) = V_T(t)$  the base current  $I_B$  and  $V_{R_2}$  are equal to zero and the storage time of the device is beginning, so considering this instant  $t_2$  that is  $t_{i_{BON}}$  you have:

**Equation 22**

$$V_T(t_2) = V_{BE} + V_C(t_2) = V_{BE} + V_{C_0} + v_C(t_2)$$

where  $V_C(t_2)$ , voltage on the capacitor  $C_2$ , is the sum of two terms  $V_{C_0}$ , that is the initial capacitor voltage, and  $v_C(t_2)$ , that is the voltage variation due to the charge of the capacitor,  $V_{BE} = 0.2V$  is base-emitter voltage when  $I_B$  is equal to zero and taking in consideration that there are charges stored into the base of the transistor.

Equalizing the two expressions 21 and 22 at this instant, you obtain:

**Equation 23**

$$V_A - \frac{(V_A - V_B) \cdot t_2}{\frac{T}{2}} = V_{BE} + V_{C_0} + v_C(t_2)$$

by considering  $V_A = 4V_B \approx 6V$ ,  $V_B = 1.5V$  and  $t_2 = t_{i_{BON}}$ .

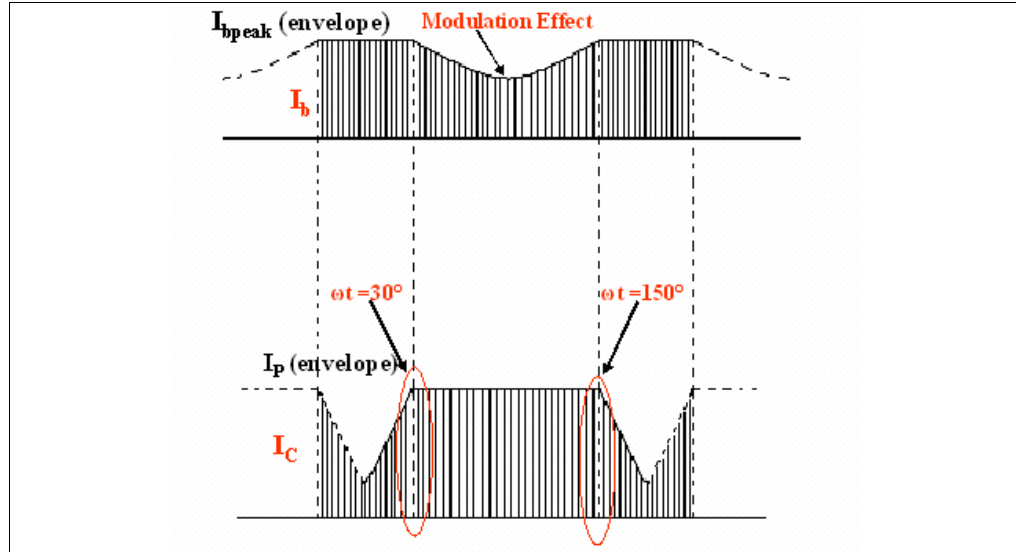
In order to calculate  $t_2 = t_{i_{BON}}$  you have:

**Equation 24**

$$t_A = t_{i_{BON}} + t_{ST} = \frac{L I_p}{V_M \sin \alpha t}$$

calculated when the collector current  $I_C$  (for  $\alpha t = 30^\circ$ ) reaches its maximum value and the base current  $I_b$  is without modulation yet (as shown in [Figure 22](#)).

Figure 22. Collector current and base current shape



Since  $v_c(t_2) = Q/C = I_{b_{peak}} \cdot t_2 / 2C$  having imposed that at the instant  $t_{BON} = t_{ST} = t_2$

#### Equation 25

$$C = \frac{I_{b_{peak}} \cdot t_2}{2 \cdot v_c(t_2)}$$

where it has been imposed  $I_{b_{peak}} = 0.75 \cdot I_p = 0.53 \text{ mA}$ .

Now from [Equation 20](#)  $V_{R_2}$  can be calculated:

#### Equation 26

$$V_{R_2} = V_T - V_{C_0} - V_{BE}$$

where  $V_{BE} = 1 \text{ V}$  is the base-emitter voltage of the device at the working current.

Then, since  $V_{R_2} = I_{b_{peak}} \cdot R_2$ ,  $R_2$  is determined:

#### Equation 27

$$R_2 = \frac{V_{R_2}}{I_{b_{peak}}}$$

It has been said that the base-emitter resistor  $R_1$  has the function to regulate the capacitor discharge during the off state of the device and to define the duty-cycle.

The mean current  $I_{R_1, \text{Mean}}$  on the  $R_1$  resistor during the off state of the device:

#### Equation 28

$$I_{R_1, \text{Mean}} = \frac{\left[ \left( \frac{V_A + V_B}{2} + 0.6 \cdot V_{C_0} \right) \right]}{R_1 + R_2}$$

where it has been considered a mean value of  $V_C = 0.6 \cdot V_{C_0}$ .

You consider the instant of the main sinusoidal in which the collector current  $I_C$  (for  $\alpha t = 30^\circ$ ) reaches its maximum value and the base current  $I_b$  without modulation yet (see [Figure 22](#)).

Multiplying this value for  $T/2$ , the amount of charge on the capacitor  $C_2$  during the off state of the device can be calculated:

**Equation 29**

$$I_{R_1, \text{Mean}} \cdot \frac{T}{2} = Q_{C_2, \text{OFF}}$$

this value must be equal at the amount of charge on the same capacitor during the on state of the device:

**Equation 30**

$$I_{R_1, \text{Mean}} \cdot \frac{T}{2} = Q_{C_2, \text{ON}} = Q_{\text{TOT}_{T_1}} + Q_{T_2}$$

Substituting [Equation 28](#) into [Equation 30](#) you obtain:

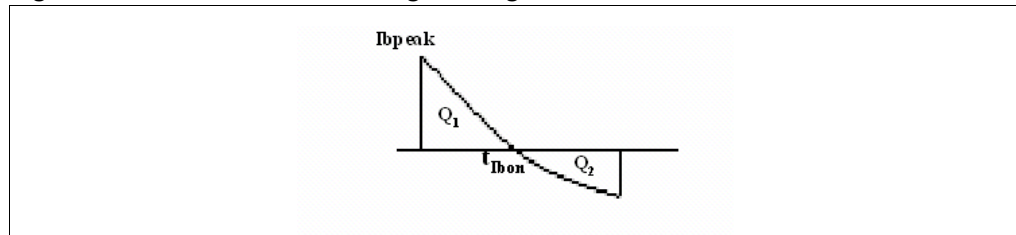
**Equation 31**

$$\left[ \frac{V_A + V_B + 0.6 \cdot V_{C_0}}{2} \right] \cdot \frac{T}{2} = Q_{\text{TOT}_{T_1}} + Q_{T_2} = Q_{C_2, \text{ON}}$$

where  $Q_{\text{TOT}_{T_1}}$  is the total amount of charge on  $T_1$  and  $Q_{T_2}$  is the amount of charge on the collector of  $T_2$ .

In the following picture it has been indicated with  $Q_1$  the amount of charge provided in the base during the turn-on of the device, while the  $Q_2$  is the amount of charge during the storage time, thus the total amount of charge is:

**Figure 23. Detail of T1 total charge during Ton**



where  $Q_2 = 0.6Q_1$  due to the recombination of some charges, so substituting in (5.13) it obtains:

**Equation 32**

$$Q_{\text{TOT}_{T_1}} = Q_1 - 0.6Q_1 = 0.4Q_1$$

**Equation 33**

but

$$Q_1 = \frac{I_{B, \text{Peak}} \cdot t_{\text{BON}}}{2}$$

Substituting [Equation 33](#) into [Equation 32](#) you obtain:

**Equation 34**

$$Q_{TOT_{T1}} = 0.4 \cdot \frac{I_{B_{Peak}} \cdot t_{b_{on}}}{2} = 0.42 \mu C$$

Now, the amount of charge on the collector of T2 is:

**Equation 35**

$$Q_{T2} = I_{CT2} \cdot t_{I_{BON}}$$

with

**Equation 36**

$$I_{CT2} = I_{B_{peak}} - I_{B_{min}}$$

Now the  $I_{B_{min}}$  at the instant where the main voltage reaches its max value,  $v(t)=V_M=310V$ .

We consider

**Equation 37**

$$v(t) = L \cdot \frac{di}{dt}$$

**Equation 38**

$$I = I_P = \frac{V}{L} t_{cond}$$

Resolving [Equation 38](#) by  $t_{cond}$ :

**Equation 39**

$$t_{cond} = \frac{I_P \cdot L}{V} = 4.5 \mu s$$

but  $t_{cond} = t_{BON} + t_{ST}$  and in this instant  $t_{BON} = t_{ST} = 2.25 \mu s$

From [Equation 32](#), we already know  $Q_{TOT_{T1}} = 0.4Q_1$ , where  $Q_{TOT_{T1}}$ , such to keep  $I_C = I_P = 0.7A$ , in this case is calculated when the base current reaches its minimum value, so knowing the  $h_{FE}$  of the device to obtain the saturation at this current value  $I_C$ , that is  $h_{FE} = 19$ , we have:

**Equation 40**

$$Q_{TOT_{T1}} = \frac{I_C}{h_{FE}} \cdot t_{cond} \cong 0.15 \mu C$$

Now from  $Q_{TOT_{T1}} = 0.4Q_1$ , we obtain:

**Equation 41**

$$Q_1 = \frac{Q_{TOT}}{0.4}$$

But

**Equation 42**

$$Q_1 = \frac{I_{BON} \cdot t_{I_{BON}}}{2}$$

So

**Equation 43**

$$I_{BON} = I_{BMIN} = \frac{2 \cdot Q_1}{t_{BON}}$$

From [Equation 36](#), we can obtain

**Equation 44**

$$I_{CT_2} = I_{Bpeak} - I_{Bmin} = 180\text{mA}$$

Then the amount of charge on the  $T_2$  collector is:

**Equation 45**

$$Q_{T_2} = I_{CT_2} \cdot t_{BON} = 0.4\mu\text{C}$$

So, the total amount of charge on the capacitor  $C_2$  during the on state of the device is:

**Equation 46**

$$Q_{C_2ON} = Q_{TOT_{T_1}} + Q_{T_2} = 0.42 + 0.4 = 0.82\mu\text{C}$$

Substituting [Equation 46](#) into [Equation 31](#) and resolving by  $R_1$ , it can be calculated:

**Equation 47**

$$R_1 = \frac{T}{2} \left( \frac{V_A + V_B}{2} + 0.6V_{C_0} \right) \left( \frac{1}{Q_{C_2ON}} \right) - R_2$$

## 4.1 Feed-Back block

In order to calculate the two resistors  $R_{13}$  and  $R_{14}$  value in [Figure 11](#) it has been imposed  $V_{Z3}=200\text{V}$ , supposing that this feed-back block acts from this voltage value.

Two instants must be considered:

1. The zener diode doesn't yet conduct for  $\alpha t=30^\circ$ ;
2. The zener diode already conducts for  $\alpha t=90^\circ$ .

Therefore the two equations to be considered are:

**Equation 48**

$$\begin{cases} \frac{V_{DCout} - V_{Z3}}{R_{14}} + \frac{V_{in}(\alpha t = 30^\circ) - V_{Z3}}{R_{13}} = 0 \\ \frac{V_{DCout} - V_{Z3}}{R_{14}} + \frac{V_{in}(\alpha t = 90^\circ) - V_{Z3}}{R_{13}} = I_{Z3} = I_{BONT_2} \end{cases}$$

where  $I_{BONT_2}$  can be calculated knowing the the peak  $h_{FE}$  of the  $T_2$  device at a minimum current value ( $I_C=50\text{mA}$ ) ( $h_{FE}=170$ ).

[Equation 48](#) has to be solved by  $R_{13}$  and  $R_{14}$ .

## 5 T Transformer and L<sub>1</sub> inductor specifications

### 5.1 220V design

The transformer T has to be chosen as following:

1. The core type is N87-EFD25/13/9 by Epcos
2. The wire gauge used to wind the transformer is 0.28 mm
3. The number of primary winding is 150 turns, the air gap length has been chosen in order to obtain a saturation current of about 1.6A and an inductance value of 2.2mH  $\pm$  2.5%
4. The number of secondary winding is 2 turns for each of the two secondaries

The Boost inductor L1 has to be chosen as following:

1. The core type is N27-E20/6 (EF20) by Epcos
2. The number of primary winding is 150 turns, the air gap length has been chosen in order to obtain a saturation current of about 1.7A and an inductance value of 1.8mH  $\pm$  2.5%
3. The wire gauge to wind the transformer is 0.22 mm

### 5.2 120V design

The transformer T has to be chosen as following:

1. The core type is N87-EFD25/13/9 by Epcos
2. The wire gauge used to wind the transformer is 0.28 mm
3. The number of primary winding is 150 turns, the air gap length has been chosen in order to obtain a saturation current of about 1.7A and an inductance value of 2.1mH  $\pm$  2.5%
4. The number of secondary winding is 3 turns in the PFC stage and 2 turns in the converter stage

The Boost inductor L1 has to be chosen as following:

1. The core type is N27-E20/6 (EF20) by Epcos
2. The number of primary winding is 150 turns, the air gap length has been chosen in order to obtain a saturation current of about 1.7A and an inductance value of 1.5mH  $\pm$  2.5%
3. The wire gauge to wind the transformer is 0.22 mm

Figure 24. 40W demoboard electrical schematic

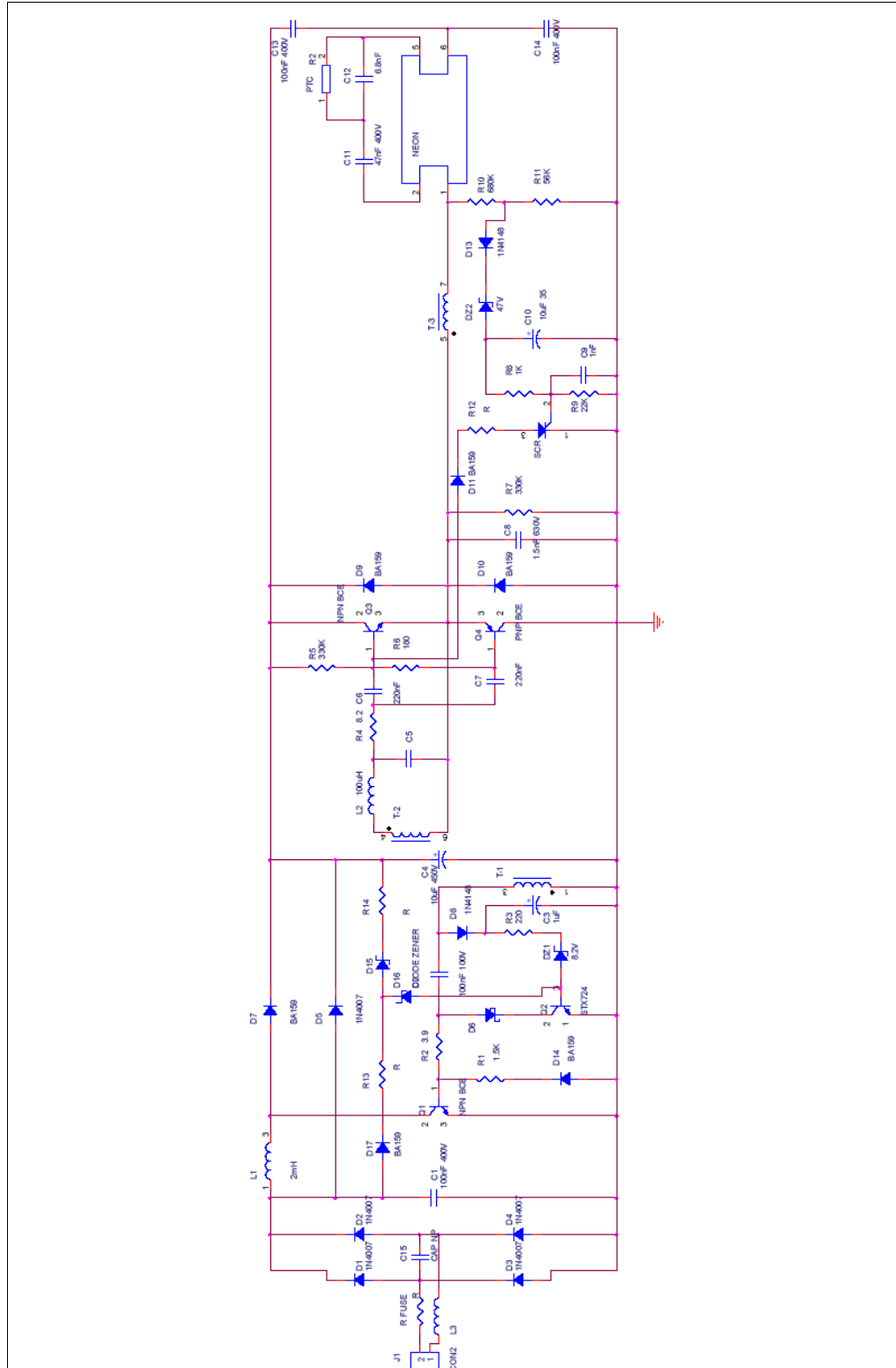




Figure 25. 40W demoboard PCB layout and mounting components

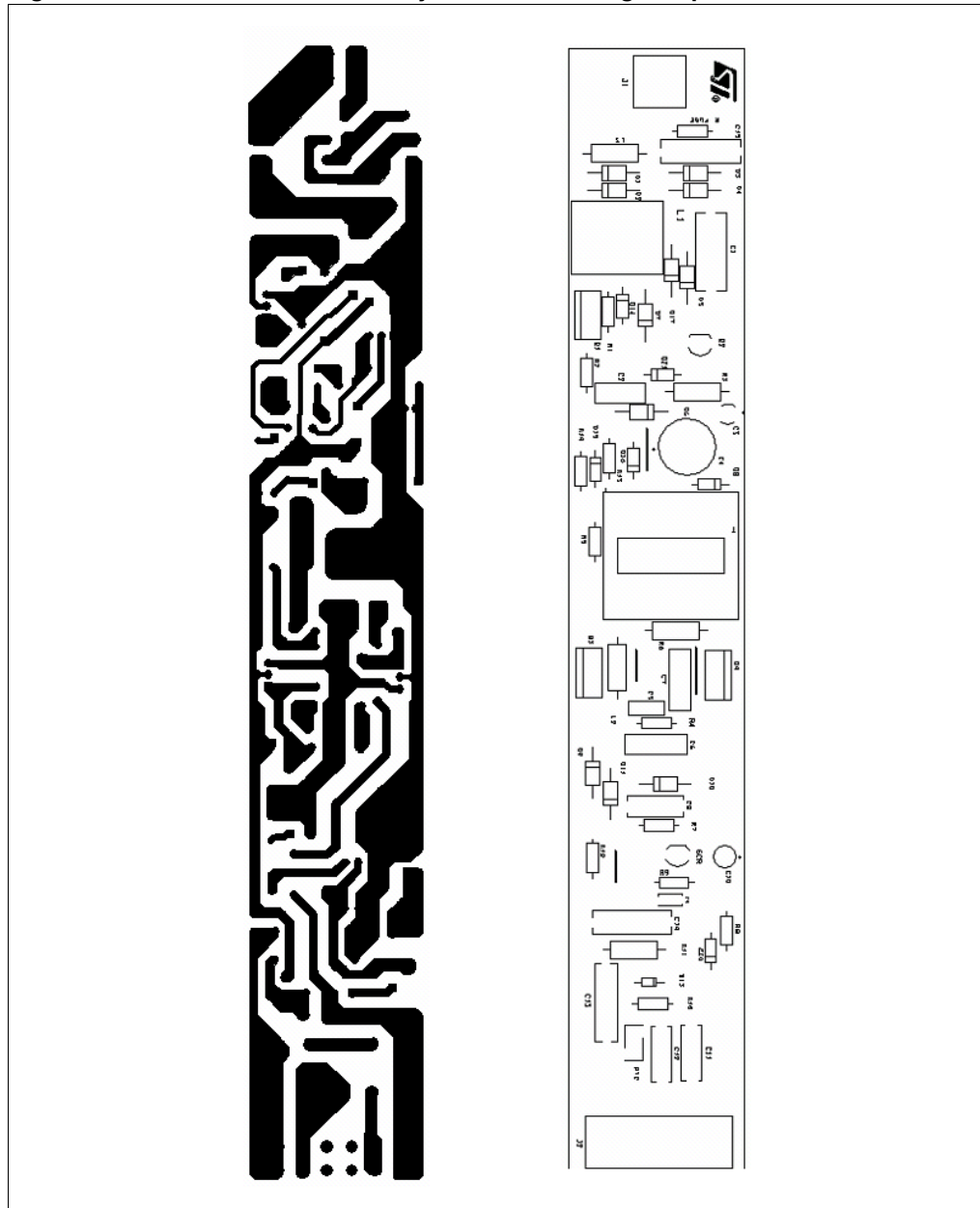


Table 1. 40W Demoboard 220V bill of materials

Item	Qty	Reference	Part	Description
1	5	D1...D5	1N4007	High Voltage Low frequency Diode
2	1	D6	1N5818	Power schotky diode
3	5	D17,D7, D9,D10,D11	BA159	High Voltage High Frquency diode
4	2	D8, D13	1N4148	Small signal diode

Table 1. 40W Demoboard 220V bill of materials (continued)

Item	Qty	Reference	Part	Description
5	1	Dz2,	47V	Glass zener diode
6	1	Dz1	5.6V	Glass zener diode
7	1	L1	1.8mH	Mounting type: Through hole. Size: 14mm x 22mm. Height: < 18mm
8	1	L2	100μH	Axial inductor 0.25W
9	1	C1	220nF 400V	Medium voltage ceramic capacitor
10	1	C2	470nF 100V	Low voltage ceramic capacitor
11	1	C3	1μF 63V	Low voltage Radial Electrolytic capacitor
12	1	C4	22uF 450V	High Voltage Electrolytic capacitor
13	1	C5	47nF 63V	Low voltage ceramic capacitor
14	2	C6, C7	220nF 100V	Low voltage ceramic capacitor
15	1	C8	1.5nF 630V	High Voltage ceramic capacitor
16	1	C9	1nF/16V	Low voltage ceramic capacitor
17	1	C10	10μF/35V	Radial Electrolytic capacitor
18	1	C11	47nF/400V	Medium Voltage ceramic capacitor
19	1	C12	6.8nF/1000V	High Voltage ceramic capacitor
20	2	C13, C14, C15	100nF/400V	Medium Voltage ceramic capacitor
22	1	R1	82Ω	0.25W 10% Axial Resistor
23	1	R2	4.7Ω	0.25W 10% Axial Resistor
24	1	R3	220Ω	0.25W 10% Axial Resistor
25	2	R5, R7	330KΩ	0.25W 10% Axial Resistor
26	1	R6	220Ω	0.25W 10% Axial Resistor
27	1	R8	1KΩ	0.25W 10% Axial Resistor
28	1	R9	22KΩ	0.25W 10% Axial Resistor
29	1	R10	680KΩ	0.25W 10% Axial Resistor
30	1	R11	56KΩ	0.25W 10% Axial Resistor
31	1	R12	39Ω	0.25W 10% Axial Resistor
32	2	R13, R14	180KΩ	0.25W 10% Axial Resistor
33	1	Rfuse	1Ω	0.25W 10% Axial Resistor
34	1	D16	200V	Zener Diode
35	1	D15	100V	Zener Diode
36	1	L3	1mH	Axial inductor 1W
37	1	SCR	X0203NA/X0202NA	TO92, $V_{DRM}/V_{RMM}=800V$ ; $I_{GT}=200 \mu A$ , $I_{TRMS}=1.25A$
38	1	PTC	R(25°C)=600Ω	Type C884 PTC thermistor, 600Ω

**Table 1. 40W Demoboard 220V bill of materials (continued)**

Item	Qty	Reference	Part	Description
39	1	T	Lp=2.3mH, Ns=2(PFC), Ns=2(Half Bridge)	Mounting type: Through hole. Size: Approx. 25mm x 25mm Height: 12 mm
40	1	D14	Short circuit	

**Table 2. 40W Demoboard 120V bill of materials**

Item	Qty	Reference	Part	Description
1	5	D1...D5	1N4007	High Voltage Low frequency Diode
2	1	D6	1N5818	Power schotky diode
3	5	D7,D9,D10,D11,D14	BA159	High Voltage High Frquency diode
4	2	D8, D13	1N4148	Small signal diode
5	1	Dz2	47V	Glass zener diode
6	1	Dz1	7.5V	Glass zener diode
7	1	L1	1.5mH	Mounting type: Through hole. Size: 14mm x 22mm. Height: < 18mm
8	1	L2	120μH	Axial inductor 0.25W
9	1	C1	680nF, 250V	Medium voltage ceramic capacitor
10	1	C2	680nF 100V	Low voltage ceramic capacitor
11	1	C3	1μF 63V	Low Voltage Radial Electrolytic capacitor
12	1	C4	22μF 400V	High Voltage Radial Electrolytic capacitor
13	1	C5	56nF 63V	Low voltage ceramic capacitor
14	2	C6, C7	220nF 100V	Low voltage ceramic capacitor
15	1	C8	2.2nF ,630V	High Voltage ceramic capacitor
16	1	C9	1nF/16V	Low voltage ceramic capacitor
17	1	C10	10uF/35V	Low Voltage Radial Electrolytic capacitor
18	1	C11	47nF/400V	Medium Voltage ceramic capacitor
19	1	C12	6.8nF/1000V	High Voltage ceramic capacitor
20	2	C13, C14	100nF/400V	Mediun Voltage ceramic capacitor
21	1	C15	220nF/250V	Medium Voltage ceramic capacitor
22	1	R1	22Ω	0.25W 10% Axial Resistor
23	1	R2	6.8Ω	0.25W 10% Axial Resistor
24	1	R3	100Ω	0.25W 10% Axial Resistor
25	1	R4	8.2Ω	0.25W 10% Axial Resistor
26	2	R5, R7	330KΩ	0.25W 10% Axial Resistor

Table 2. 40W Demoboard 120V bill of materials (continued)

Item	Qty	Reference	Part	Description
27	1	R6	220Ω	0.25W 10% Axial Resistor
28	1	R8	1KΩ	0.25W 10% Axial Resistor
29	1	R9	22KΩ	0.25W 10% Axial Resistor
30	1	R10	680KΩ	0.25W 10% Axial Resistor
31	1	R11	56KΩ	0.25W 10% Axial Resistor
32	1	R12	39Ω	0.25W 10% Axial Resistor
33	1	R13	220KΩ	0.25W 10% Axial Resistor
34	1	R14	68KΩ	0.25 W 10% Axial Resistor
35	1	L ( in place of Rfuse )	1mH	Axial inductor 1W 10%
36	1	D16	130V	Zener Diode
37	1	D15	180V	Zener Diode
38	1	L3	1mH	Axial inductor 1W
39	1	SCR	X0203NA/X0202NA	TO92, $V_{DRM}/V_{RMM}=800V$ ; $I_{GT}=200 \mu A$ , $I_{TRMS}=1.25A$
40	1	PTC	R(25°C)=600Ω	Type C884 PTC thermistor, 600Ω
41	1	T	Lp=2.1mH, Ns=3(PFC), Ns=2(Half Bridge)	Mounting type: Through hole. Size: Approx. 25mm x 25mm Height: 12mm
42	1	D17	Short circuit	

## 6 Revision history

Table 3. Document revision history

Date	Revision	Changes
06-Jun-2006	1	Initial release

**Please Read Carefully:**

Information in this document is provided solely in connection with ST products. STMicroelectronics NV and its subsidiaries ("ST") reserve the right to make changes, corrections, modifications or improvements, to this document, and the products and services described herein at any time, without notice.

All ST products are sold pursuant to ST's terms and conditions of sale.

Purchasers are solely responsible for the choice, selection and use of the ST products and services described herein, and ST assumes no liability whatsoever relating to the choice, selection or use of the ST products and services described herein.

No license, express or implied, by estoppel or otherwise, to any intellectual property rights is granted under this document. If any part of this document refers to any third party products or services it shall not be deemed a license grant by ST for the use of such third party products or services, or any intellectual property contained therein or considered as a warranty covering the use in any manner whatsoever of such third party products or services or any intellectual property contained therein.

**UNLESS OTHERWISE SET FORTH IN ST'S TERMS AND CONDITIONS OF SALE ST DISCLAIMS ANY EXPRESS OR IMPLIED WARRANTY WITH RESPECT TO THE USE AND/OR SALE OF ST PRODUCTS INCLUDING WITHOUT LIMITATION IMPLIED WARRANTIES OF MERCHANTABILITY, FITNESS FOR A PARTICULAR PURPOSE (AND THEIR EQUIVALENTS UNDER THE LAWS OF ANY JURISDICTION), OR INFRINGEMENT OF ANY PATENT, COPYRIGHT OR OTHER INTELLECTUAL PROPERTY RIGHT.**

**UNLESS EXPRESSLY APPROVED IN WRITING BY AN AUTHORIZED REPRESENTATIVE OF ST, ST PRODUCTS ARE NOT DESIGNED, AUTHORIZED OR WARRANTED FOR USE IN MILITARY, AIR CRAFT, SPACE, LIFE SAVING, OR LIFE SUSTAINING APPLICATIONS, NOR IN PRODUCTS OR SYSTEMS, WHERE FAILURE OR MALFUNCTION MAY RESULT IN PERSONAL INJURY, DEATH, OR SEVERE PROPERTY OR ENVIRONMENTAL DAMAGE.**

Resale of ST products with provisions different from the statements and/or technical features set forth in this document shall immediately void any warranty granted by ST for the ST product or service described herein and shall not create or extend in any manner whatsoever, any liability of ST.

ST and the ST logo are trademarks or registered trademarks of ST in various countries.

Information in this document supersedes and replaces all information previously supplied.

The ST logo is a registered trademark of STMicroelectronics. All other names are the property of their respective owners.

© 2006 STMicroelectronics - All rights reserved

STMicroelectronics group of companies

Australia - Belgium - Brazil - Canada - China - Czech Republic - Finland - France - Germany - Hong Kong - India - Israel - Italy - Japan - Malaysia - Malta - Morocco - Singapore - Spain - Sweden - Switzerland - United Kingdom - United States of America

[www.st.com](http://www.st.com)