

NCP1392B

High-Voltage Half-Bridge Driver with Inbuilt Oscillator

The NCP1392B is a self-oscillating high voltage MOSFET driver primarily tailored for the applications using half bridge topology. Due to its proprietary high-voltage technology, the driver accepts bulk voltages up to 600 V. Operating frequency of the driver can be adjusted from 25 kHz to 250 kHz using a single resistor. Adjustable Brown-out protection assures correct bulk voltage operating range. An internal 100 ms PFC delay timer guarantee that the main downstream converter will be turned on in the time the bulk voltage is fully stabilized. The device provides fixed dead time which helps lowering the shoot-through current.

Features

- Wide Operating Frequency Range – from 25 kHz to 250 kHz
- Minimum frequency adjust accuracy $\pm 3\%$
- Fixed Dead Time – 0.6 μs
- Adjustable Brown-out Protection for a Simple PFC Association
- 100 ms PFC Delay Timer
- Non-latched Enable Input
- Internal 16 V V_{CC} Clamp
- Low Startup Current of 50 μA
- 1 A / 0.5 A Peak Current Sink / Source Drive Capability
- Operation up to 600 V Bulk Voltage
- Internal Temperature Shutdown
- SOIC-8 or PDIP-8 Package
- These are Pb-Free Devices

Typical Applications

- Flat Panel Display Power Converters
- Low Cost Resonant SMPS
- High Power AC/DC Adapters for Notebooks
- Offline Battery Chargers
- Lamp Ballasts



ON Semiconductor®

<http://onsemi.com>



SOIC-8
CASE 751

MARKING DIAGRAMS

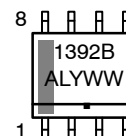

- A = Assembly Location
- L = Wafer Lot
- Y = Year
- WW = Work Week
- = Pb-Free Package

PINOUT

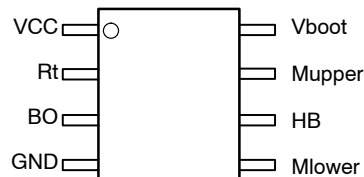

ORDERING INFORMATION

Device	Package	Shipping†
NCP1392BDR2G	SOIC-8 (Pb-Free)	2500 / Tape & Reel

†For information on tape and reel specifications, including part orientation and tape sizes, please refer to our Tape and Reel Packaging Specifications Brochure, BRD8011/D.

NCP1392B

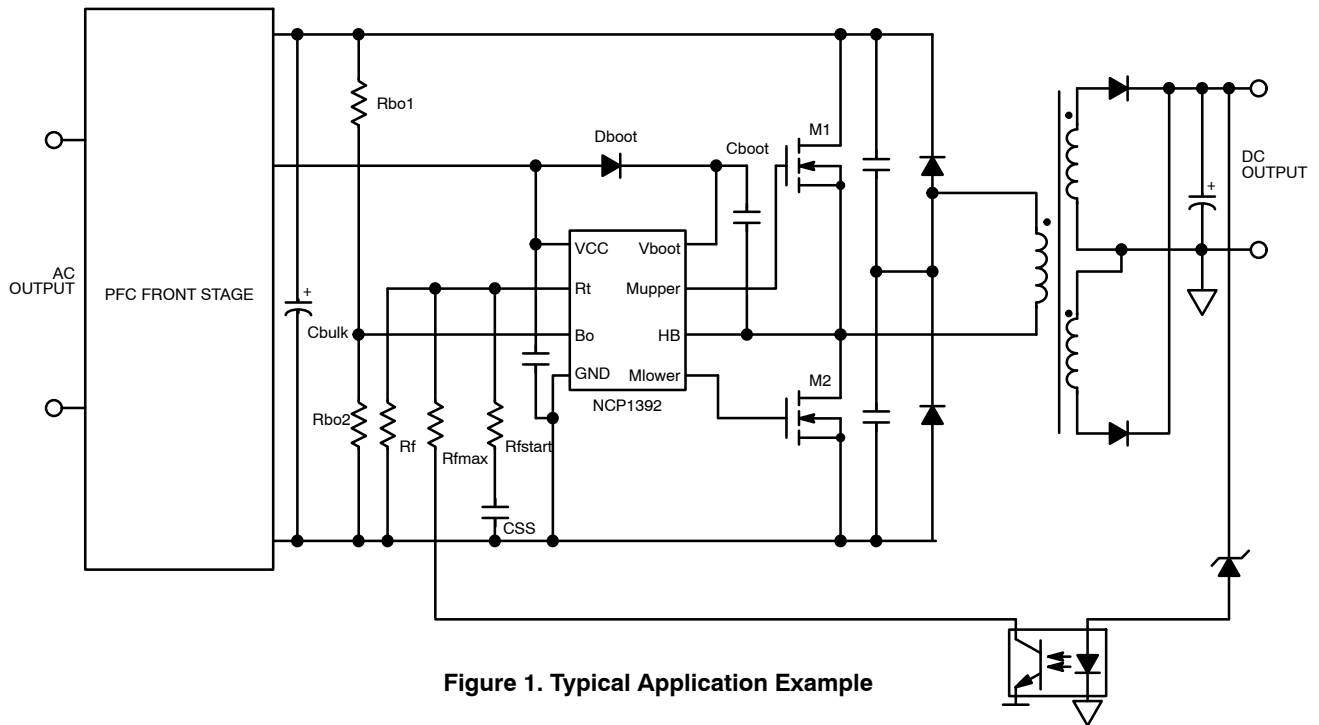

Figure 1. Typical Application Example

PIN FUNCTION DESCRIPTION

Pin #	Pin Name	Function	Pin Description
1	V _{CC}	Supplies the Driver	The driver accepts up to 16 V (given by internal zener clamp)
2	R _t	Timing Resistor	Connecting a resistor between this pin and GND, sets the operating frequency
3	BO	Brown-Out	Detects low input voltage conditions. When brought above V _{ref_EN} , it stops the driver. Operation is restored (without any delay) when BO pin voltage drops 100 mV below V _{ref_EN} .
4	GND	IC Ground	
5	M _{lower}	Low-Side Driver Output	Drives the lower side MOSFET
6	HB	Half-Bridge Connection	Connects to the half-bridge output
7	M _{upper}	High-Side Driver Output	Drives the higher side MOSFET
8	V _{boot}	Bootstrap Pin	The floating supply terminal for the upper stage

NCP1392B

MAXIMUM RATINGS TABLE

Symbol	Rating	Value	Unit
V _{bridge}	High Voltage Bridge Pin – Pin 6	-1 to +600	V
V _{boot} – V _{bridge}	Floating Supply Voltage	0 to 20	V
VDRV_HI	High-Side Output Voltage	V _{bridge} – 0.3 to V _{boot} + 0.3	V
VDRV_LO	Low-Side Output Voltage	-0.3 to V _{CC} + 0.3	V
dV _{bridge} /dt	Allowable Output Slew Rate	± 50	V/ns
I _{CC}	Maximum Current that Can Flow into V _{CC} Pin (Pin 1), (Note 1)	20	mA
V _{Rt}	Rt Pin Voltage	-0.3 to 5	V
	Maximum Voltage, All Pins (Except Pins 4 and 5)	-0.3 to 10	V
R _{θJA}	Thermal Resistance Junction-to-Air, IC Soldered on 50 mm ² Cooper 35 μm	178	°C/W
R _{θJA}	Thermal Resistance Junction-to-Air, IC Soldered on 200 mm ² Cooper 35 μm	147	°C/W
	Storage Temperature Range	-60 to +150	°C
	ESD Capability, Human Body Model (All Pins Except Pins 1, 6, 7 and 8)	2	kV
	ESD Capability, Machine Model (All Pins Except Pins 1, 6, 7 and 8)	200	V

Stresses exceeding Maximum Ratings may damage the device. Maximum Ratings are stress ratings only. Functional operation above the Recommended Operating Conditions is not implied. Extended exposure to stresses above the Recommended Operating Conditions may affect device reliability.

1. This device contains internal zener clamp connected between V_{CC} and GND terminals. Current flowing into the V_{CC} pin has to be limited by an external resistor when device is supplied from supply which voltage is higher than V_{CCclamp} (16 V typically). The I_{CC} parameter is specified for V_{BO} = 0 V.

NCP1392B

ELECTRICAL CHARACTERISTICS (For typical values $T_J = 25^\circ\text{C}$, for min/max values $T_J = -40^\circ\text{C}$ to $+125^\circ\text{C}$, Max $T_J = 150^\circ\text{C}$, $V_{CC} = 12\text{ V}$, unless otherwise noted)

Characteristic	Pin	Symbol	Min	Typ	Max	Unit
SUPPLY SECTION						
Turn-On Threshold Level, V_{CC} Going Up	1	$V_{CC_{ON}}$	10	11	12	V
Minimum Operating Voltage after Turn-On	1	$V_{CC_{min}}$	8	9	10	V
Startup Voltage on the Floating Section	1	$V_{boot_{ON}}$	7.8	8.8	9.8	V
Cutoff Voltage on the Floating Section,	1	$V_{boot_{min}}$	7	8	9	V
V_{CC} Level at which the Internal Logic gets Reset	1	$V_{CC_{reset}}$	-	6.5	-	V
Startup Current, $V_{CC} < V_{CC_{ON}}$, $0^\circ\text{C} \leq T_{amb} \leq +125^\circ\text{C}$	1	I_{CC}	-	-	50	μA
Startup Current, $V_{CC} < V_{CC_{ON}}$, $-40^\circ\text{C} \leq T_{amb} < 0^\circ\text{C}$	1	I_{CC}	-	-	65	μA
Internal IC Consumption, No Output Load on Pins 8/7 – 5/4, $F_{sw} = 100\text{ kHz}$	1	I_{CC1}	-	2.2	-	mA
Internal IC Consumption, 1 nF Output Load on Pins 8/7 – 5/4, $F_{sw} = 100\text{ kHz}$	1	I_{CC2}	-	3.4	-	mA
Consumption in Fault Mode (Drivers Disabled, $V_{CC} > V_{CC_{(min)}}$, $R_T = 3.5\text{ k}\Omega$)	1	I_{CC3}	-	2.56	-	mA
Consumption During PFC Delay Period, $0^\circ\text{C} \leq T_{amb} \leq +125^\circ\text{C}$		I_{CC4}	-	-	400	μA
Consumption During PFC Delay Period, $-40^\circ\text{C} \leq T_{amb} < 0^\circ\text{C}$		I_{CC4}	-	-	470	μA
Internal IC Consumption, No Output Load on Pin 8/7 $F_{SW} = 100\text{ kHz}$	8	I_{boot1}	-	0.3	-	mA
Internal IC Consumption, 1 nF Load on Pin 8/7 $F_{SW} = 100\text{ kHz}$	8	I_{boot2}	-	1.44	-	mA
Consumption in Fault Mode (Drivers Disabled, $V_{boot} > V_{boot_{min}}$)	8	I_{boot3}	-	0.1	-	mA
V_{CC} Zener Clamp Voltage @ 20 mA	1	$V_{CC_{clamp}}$	15.4	16	17.5	V

INTERNAL OSCILLATOR

Minimum Switching Frequency, $R_t = 35\text{ k}\Omega$ on Pin 2, $D_T = 600\text{ ns}$	2	$F_{SW\ min}$	24.25	25	25.75	kHz
Maximum Switching Frequency, $R_t = 3.5\text{ k}\Omega$ on Pin 2, $D_T = 600\text{ ns}$	2	$F_{SW\ max}$	208	245	282	kHz
Reference Voltage for all Current Generations	2	$V_{ref\ RT}$	3.33	3.5	3.67	V
Internal Resistance Discharging $C_{soft-start}$	2	$R_{t_{discharge}}$	-	500	-	Ω
Operating Duty Cycle Symmetry	5, 7	DC	48	50	52	%

NOTE: Maximum capacitance directly connected to Pin 2 must be under 100 pF.

DRIVE OUTPUT

Output Voltage Rise Time @ $CL = 1\text{ nF}$, 10–90% of Output Signal	5, 7	T_r	-	40	-	ns
Output Voltage Fall Time @ $CL = 1\text{ nF}$, 10–90% of Output Signal	5, 7	T_f	-	20	-	ns
Source Resistance	5, 7	R_{OH}	-	12	-	Ω
Sink Resistance	5, 7	R_{OL}	-	5	-	Ω
Deadtime	5, 7	T_{dead}	540	610	720	ns
Leakage Current on High Voltage Pins to GND (600 Vdc)	6, 7, 8	$I_{HV_{Leak}}$	-	-	5	μA

PROTECTION

Brown-Out Input Bias Current	3	$I_{BO_{bias}}$	-	0.01	-	μA
Brown-Out Level	3	VBO	0.95	1	1.05	V
Hysteresis Current, $V_{pin3} < V_{BO}$	3	IBO	15.6	18.2	20.7	μA
Reference Voltage for EN Input	3	$V_{ref\ EN}$	1.9	2	2.1	V
Enable Comparator Hysteresis	3	EN_Hyste	-	100	-	mV
Propagation Delay Before Drivers are Stopped	3	EN_Delay	-	0.5	-	μs
Delay Before Any Driver Restart	-	PFC Delay	-	100	-	ms
Temperature Shutdown	-	TSD	140	-	-	$^\circ\text{C}$
Hysteresis	-	TSDhyste	-	30	-	$^\circ\text{C}$

NCP1392B

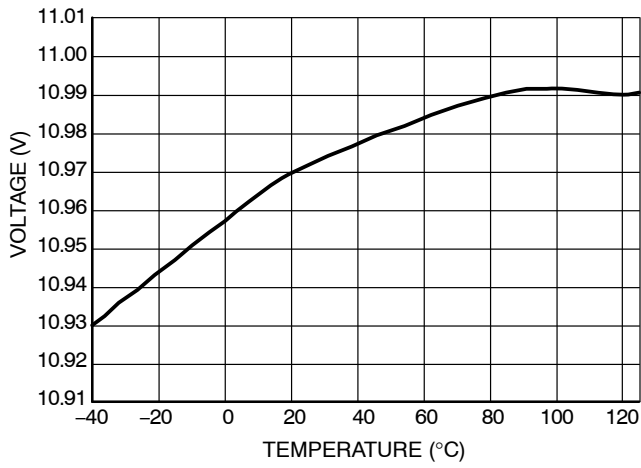

Figure 3. V_{CCon}

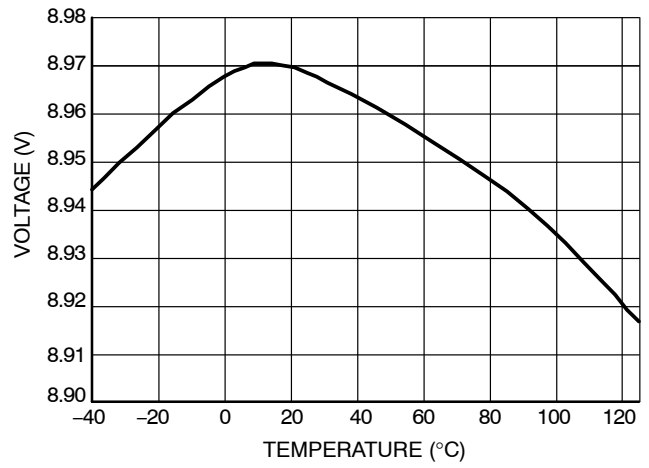

Figure 4. V_{CCmin}

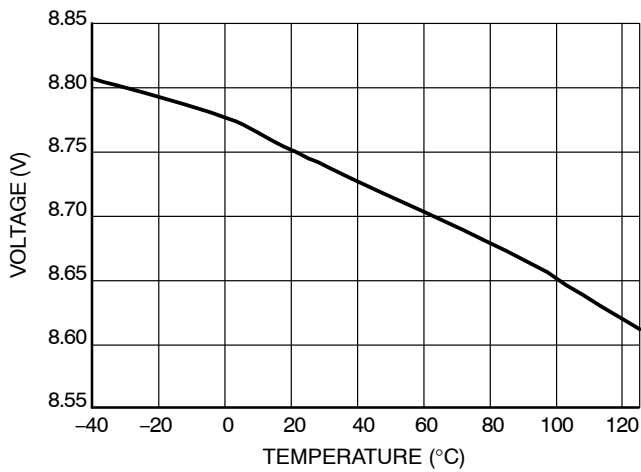

Figure 5. V_{BOOTon}

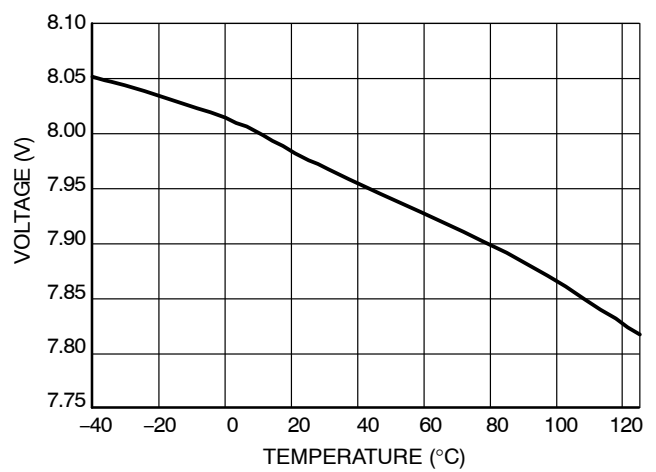

Figure 6. $V_{BOOTmin}$

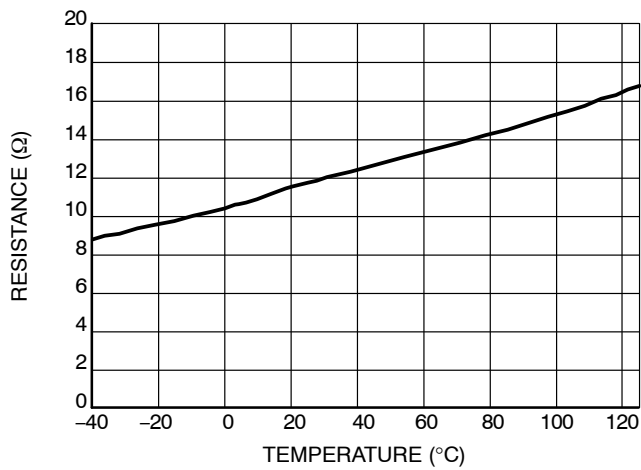

Figure 7. R_{OH}

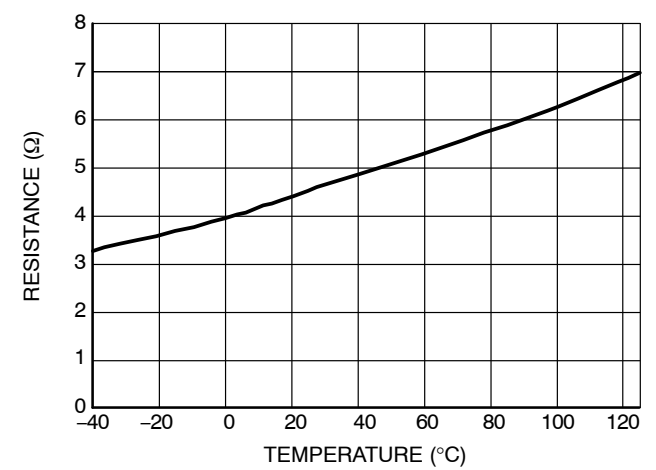

Figure 8. R_{OL}

NCP1392B

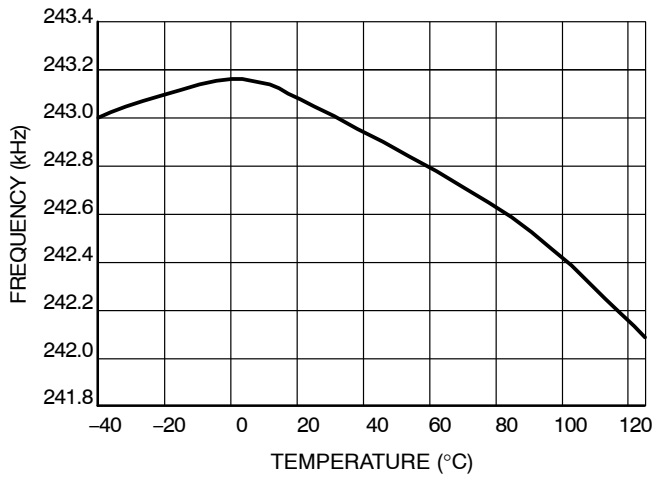

Figure 9. F_{swmax}

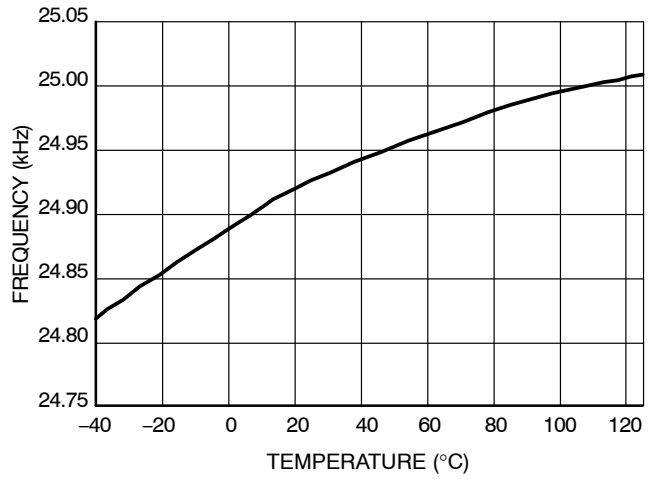

Figure 10. F_{swmin}

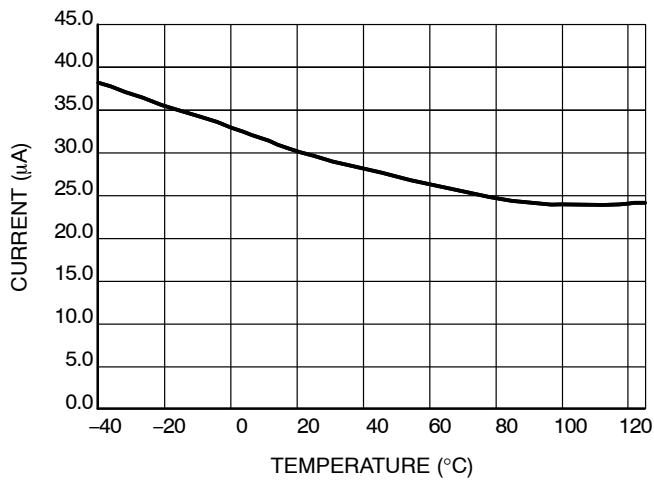

Figure 11. I_{cc_startup}

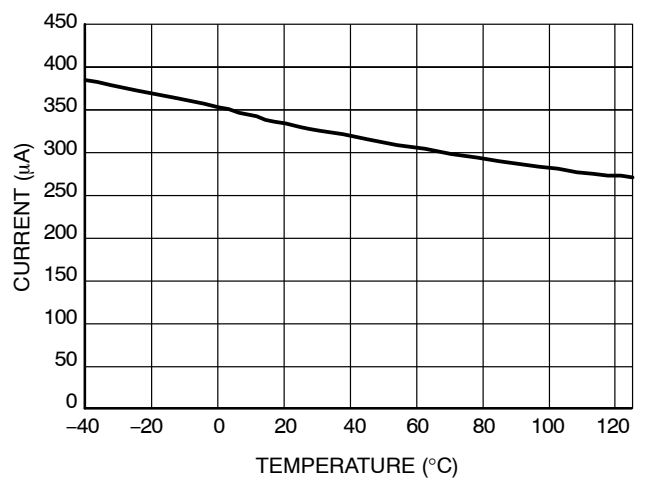

Figure 12. I_{cc4}

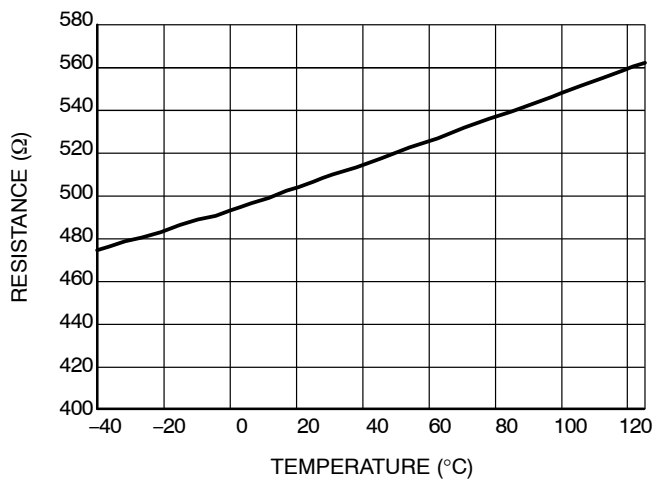

Figure 13. R_{t_discharge}

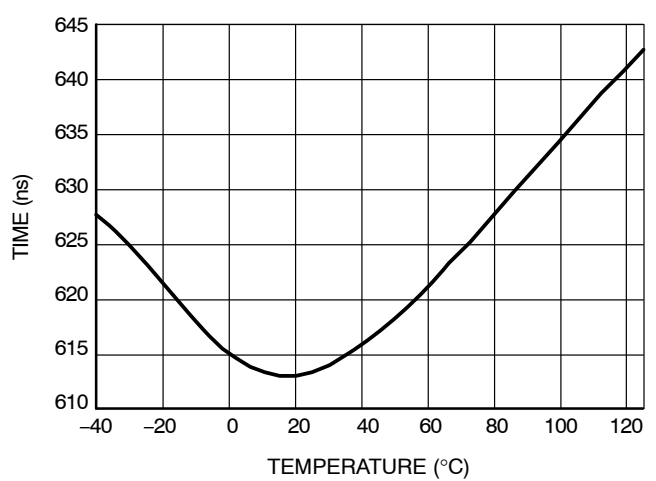

Figure 14. T_{dead}

NCP1392B

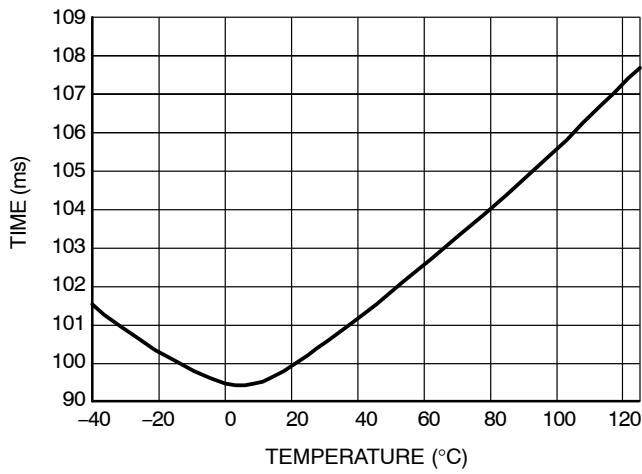

Figure 15. PFC_{delay}

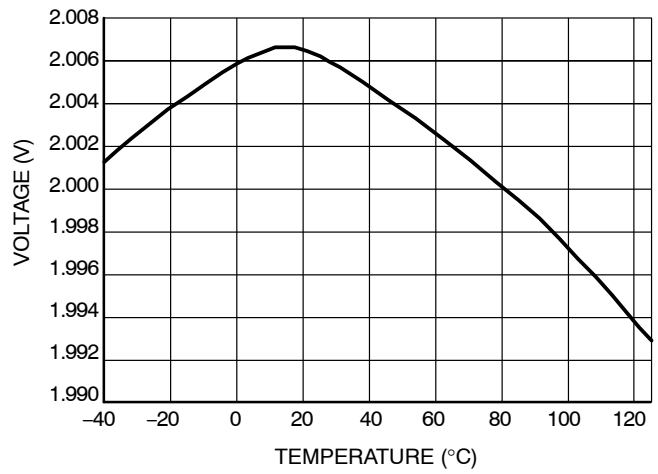

Figure 16. V_{ref_EN}

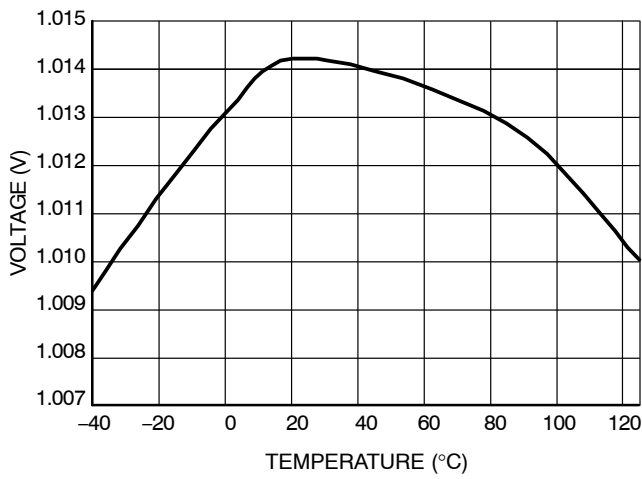

Figure 17. V_{BO}

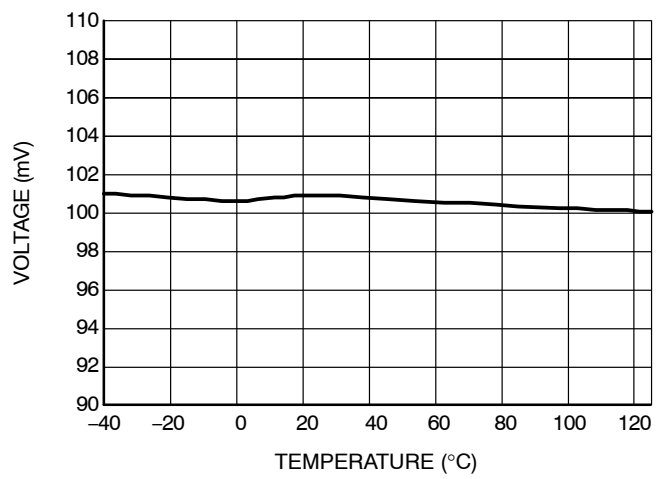

Figure 18. EN_{hyste}

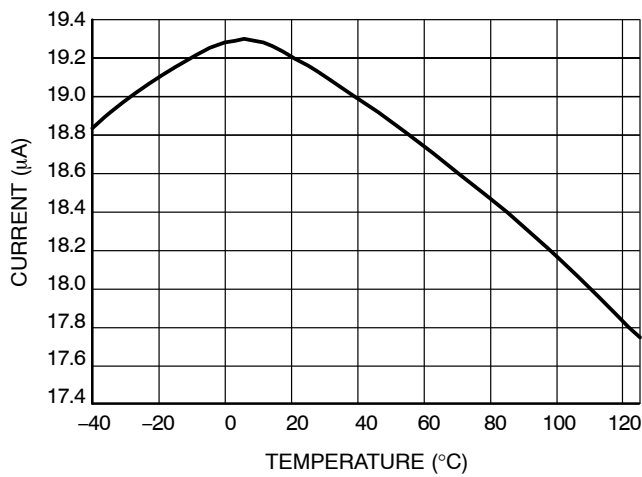

Figure 19. I_{BO}

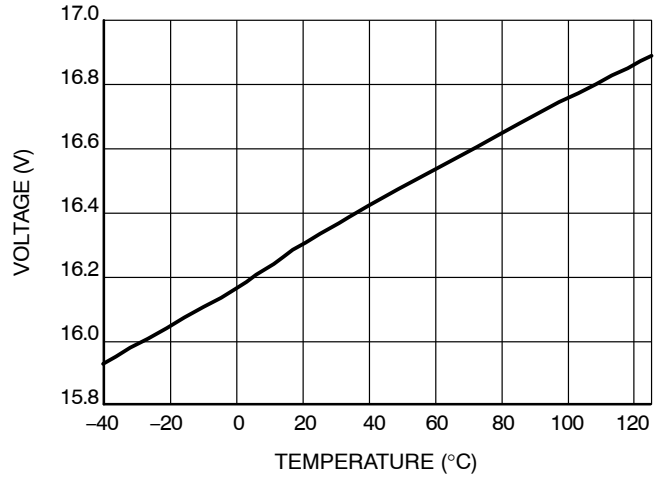

Figure 20. V_{CC_clamp}

NCP1392B

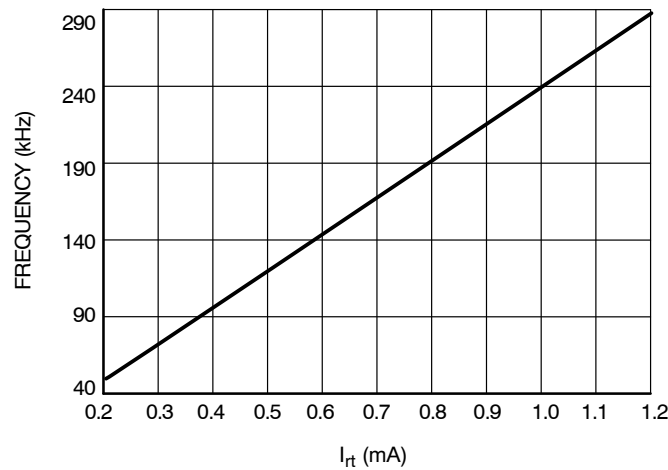

Figure 21. I_{Rt} and Appropriate Frequency

APPLICATION INFORMATION

The NCP1392 is primarily intended to drive low cost half bridge applications and especially resonant half bridge applications. The IC includes several features that help the designer to cope with resonant SPMS design. All features are described thereafter:

- **Wide Operating Frequency Range:** The internal current controlled oscillator is capable to operate over wide frequency range up to 250 kHz. Minimum frequency accuracy is $\pm 3\%$.
- **Fixed Dead-Time:** The internal dead-time helping to fight with cross conduction between the upper and lower power transistors. Three versions with different dead time values are available to cover wide range of applications.
- **100 ms PFC Timer:** Fixed delay is placed to IC operation whenever the driver restarts ($V_{CC_{ON}}$ or BO_OK detect events). This delay assures that the bulk voltage will be stabilized in the time the driver provides pulses on the outputs. Another benefit of this delay is that the soft start capacitor will be full discharged before any restart.
- **Brown-Out Detection:** The BO input monitors bulk voltage level via resistor divider and thus assures that the application is working only for wanted bulk voltage band. The BO input sinks current of $18.2 \mu A$ until the $V_{ref_{BO}}$ threshold is reached. Designer can thus adjust the bulk voltage hysteresis according to the application needs.

- **Non-Latched Enable Input:** The enable comparator input is connected in parallel to the BO terminal to allow the designer stop the output drivers when needed. There is no PFC delay when enable input is released so skip mode for resonant SMPS applications and dimming for light ballast applications are possible.
- **Internal V_{CC} Clamp:** The internal zener clamp offers a way to prepare passive voltage regulator to maintain V_{CC} voltage at 16 V in case the controller is supplied from unregulated power supply or from bulk capacitor.
- **Low Startup Current:** This device features maximum startup current of $50 \mu A$ which allows the designer to use high value startup resistor for applications when driver is supplied from the auxiliary winding. Power dissipation of startup resistor is thus significantly reduced.

Current Controlled Oscillator

The current controlled oscillator features a high-speed circuitry allowing operation from 50 kHz up to 500 kHz. However, as a division by two internally creates the two Q and \bar{Q} outputs, the final effective signal on output M_{lower} and M_{upper} switches between 25 kHz and 250 kHz. The VCO is configured in such a way that if the current that flows out from the Rt pin increases, the switching frequency also goes up. Figure 22 shows the architecture of this oscillator.

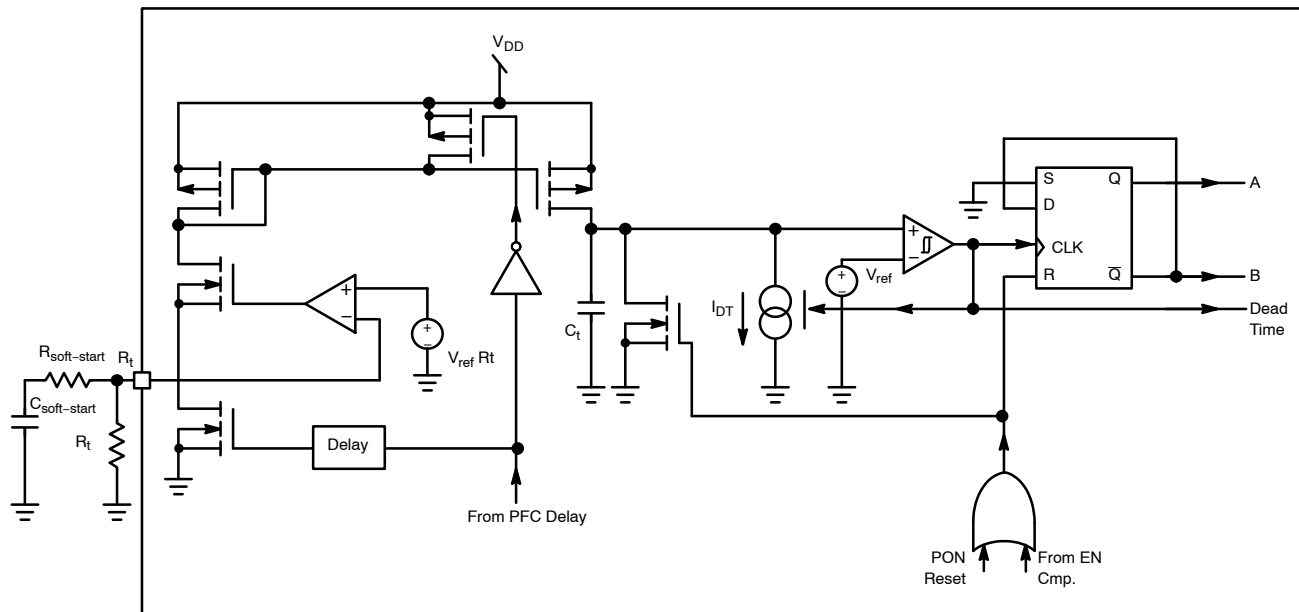

Figure 22. The Internal Current Controlled Oscillator Architecture

The internal timing capacitor C_t is charged by current which is proportional to the current flowing out from the R_t pin. The discharging current I_{DT} is applied when voltage on this capacitor reaches 2.5 V. The output drivers are disabled during discharge period so the dead time length is given by the discharge current sink capability. Discharge sink is disabled when voltage on the timing capacitor reaches zero and charging cycle starts again. The charging current and thus also whole oscillator is disabled during the PFC delay period to keep the IC consumption below 400 μ A.

This is valuable for applications that are supplied from auxiliary winding and V_{CC} capacitor is supposed to provide energy during PFC delay period.

For the resonant applications and light ballast applications it is necessary to adjust minimum operating frequency with high accuracy. The designer also needs to limit maximum operating and startup frequency. All these parameters can be adjusted using few external components connected to the R_t pin as depicted in Figure 23.

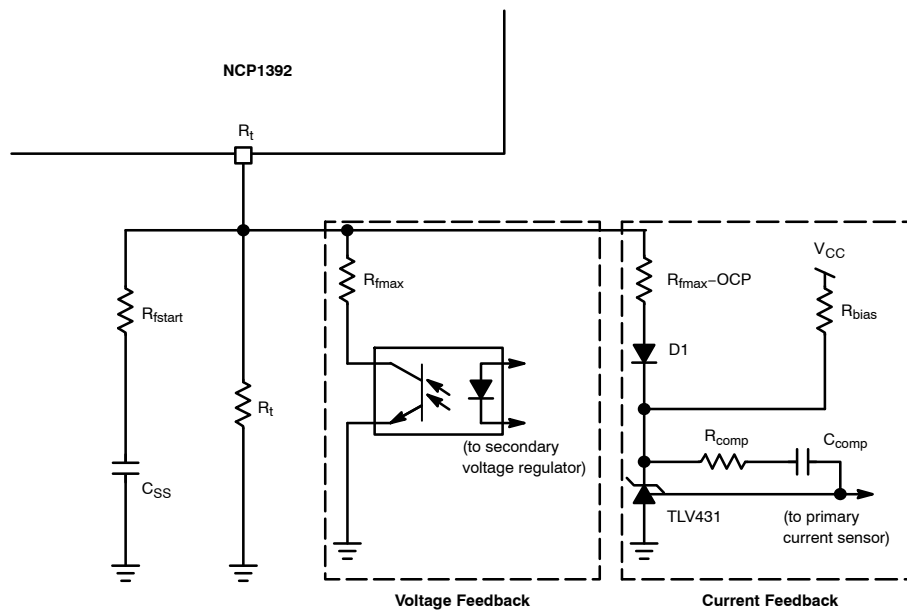

Figure 23. Typical R_t Pin Connection

The minimum switching frequency is given by the R_t resistor value. This frequency is reached if there is no optocoupler or current feedback action and soft start period

has been already finished. The maximum switching frequency excursion is limited by the R_{fmax} selection. Note that the F_{max} value is influenced by the optocoupler

saturation voltage value. Resistor R_{start} together with capacitor C_{SS} prepares the soft start period after PFC timer elapses. The R_t pin is grounded via an internal switch during the PFC delay period to assure that the soft start capacitor will be fully discharged via R_{start} resistor.

There is a possibility to connect other control loops (like current control loop) to the R_t pin. The only one limitation lies in the R_t pin reference voltage which is $V_{ref_{Rt}} = 3.5\text{ V}$. Used regulator has to be capable to work with voltage lower than $V_{ref_{Rt}}$.

The TLV431 shunt regulator is used in the example from figure 4 to prepare current feedback loop. Diode D1 is used to enable regulator biasing via resistor R_{bias} . Total saturation voltage of this solution is $1.25 + 0.6 = 1.85\text{ V}$ for

room temperature. Shottky diode will further decrease saturation voltage. $R_{f_{max}}$ – OCP resistor value, limits the maximum frequency that can be pushed by this regulation loop. This parameter is not temperature stable because of the D1 temperature drift.

Brown-Out Protection

The Brown-Out circuitry (BO) offers a way to protect the application from low DC input voltages. Below a given level, the controller blocks the output pulses, above it, it authorizes them. The internal circuitry, depicted by Figure 24, offers a way to observe the high-voltage (HV) rail.

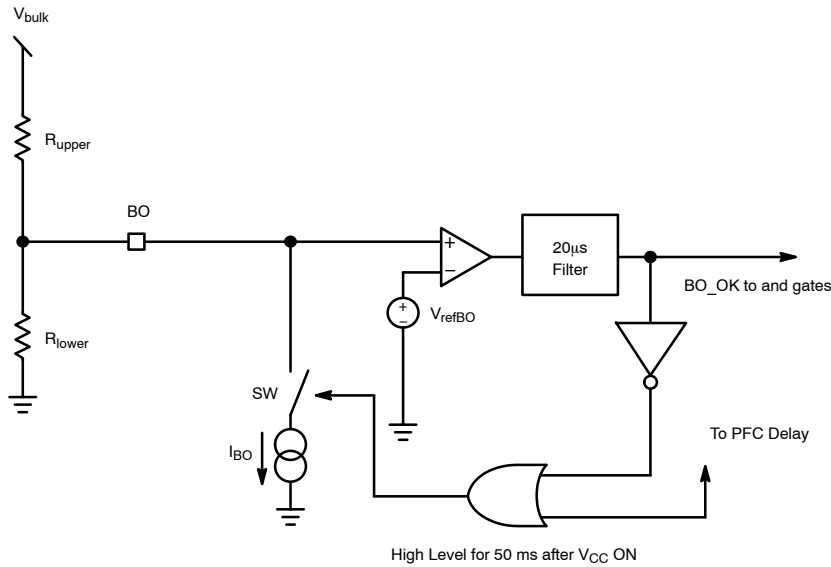

Figure 24. The internal Brown-Out Configuration with an Offset Current Sink

A resistive divider made of R_{upper} and R_{lower} , brings a portion of the HV rail on Pin 3. Below the turn-on level, the $18.2\text{ }\mu\text{A}$ current sink (I_{BO}) is on. Therefore, the turn-on level is higher than the level given by the division ratio brought by the resistive divider. To the contrary, when the

internal BO_OK signal is high (PFC timer runs or M_{lower} and M_{upper} pulse), the I_{BO} sink is deactivated. As a result, it becomes possible to select the turn-on and turn-off levels via a few lines of algebra:

IBO is on

$$V_{ref_{BO}} = V_{bulk1} \cdot \frac{R_{lower}}{R_{lower} + R_{upper}} - I_{BO} \cdot \left(\frac{R_{lower} \cdot R_{upper}}{R_{lower} + R_{upper}} \right) \tag{eq. 1}$$

IBO is off

$$V_{ref_{BO}} = V_{bulk2} \cdot \frac{R_{lower}}{R_{lower} + R_{upper}} \tag{eq. 2}$$

We can extract R_{lower} from Equation 2 and plug it into Equation 1, then solve for R_{upper} :

$$R_{lower} = V_{ref_{BO}} \cdot \frac{V_{bulk1} - V_{bulk2}}{I_{BO} \cdot (V_{bulk2} - V_{ref_{BO}})} \tag{eq. 3}$$

$$R_{upper} = R_{lower} \cdot \frac{V_{bulk2} - V_{ref_{BO}}}{V_{ref_{BO}}} \tag{eq. 4}$$

NCP1392B

If we decide to turn-on our converter for V_{bulk1} equals 350 V and turn it off for V_{bulk2} equals 250 V, then for $I_{\text{BO}} = 18.2 \mu\text{A}$ and $V_{\text{refBO}} = 1.0 \text{ V}$ we obtain:

$$R_{\text{upper}} = 5.494 \text{ M}\Omega$$

$$R_{\text{lower}} = 22.066 \text{ k}\Omega$$

The bridge power dissipation is $400^2 / 5.517 \text{ M}\Omega = 29 \text{ mW}$ when front-end PFC stage delivers 400 V. Figure 25 simulation result confirms our calculations.

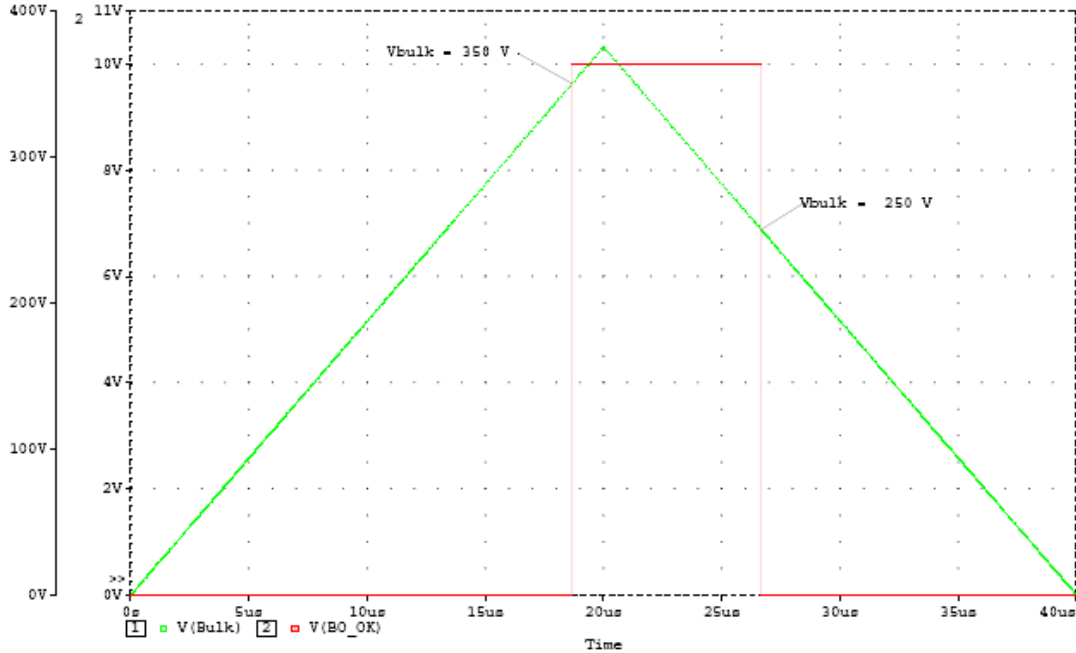

Figure 25. Simulation Results for 350/250 ON/OFF Brown-Out Levels

The IBO current sink is turned ON for 50 ms after any controller restart to let the BO input voltage stabilize (there can be connected big capacitor to the BO input and the IBO is only $18.2 \mu\text{A}$ so it will take some time to discharge). Once the 50 ms one shoot pulse ends the BO comparator is

supposed to either hold the I_{BO} sink turned ON (if the bulk voltage level is not sufficient) or let it turned OFF (if the bulk voltage is higher than V_{bulk1}).

See figures 10 – 13 for better understanding on how the BO input works.

NCP1392B

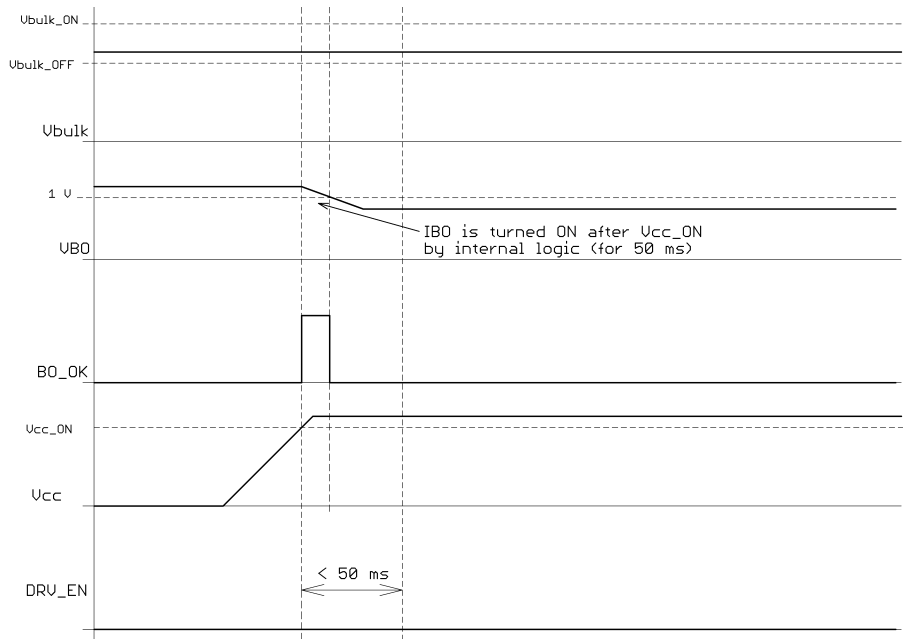

Figure 26. BO Input Functionality – $V_{bulk2} < V_{bulk} < V_{bulk1}$

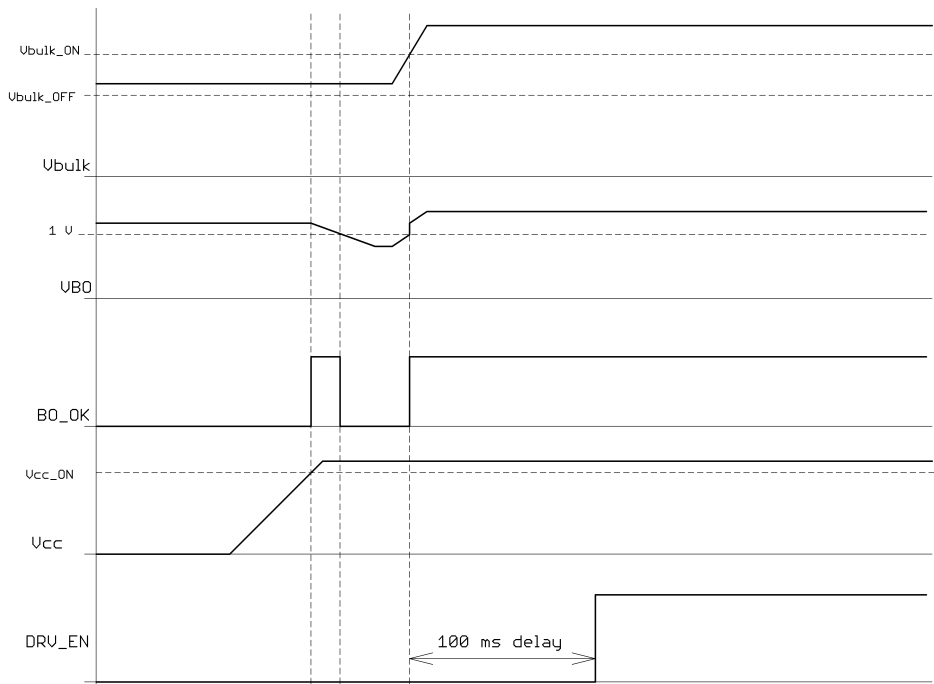

Figure 27. BO Input Functionality – $V_{bulk2} < V_{bulk} < V_{bulk1}$, PFC Start Follows

NCP1392B

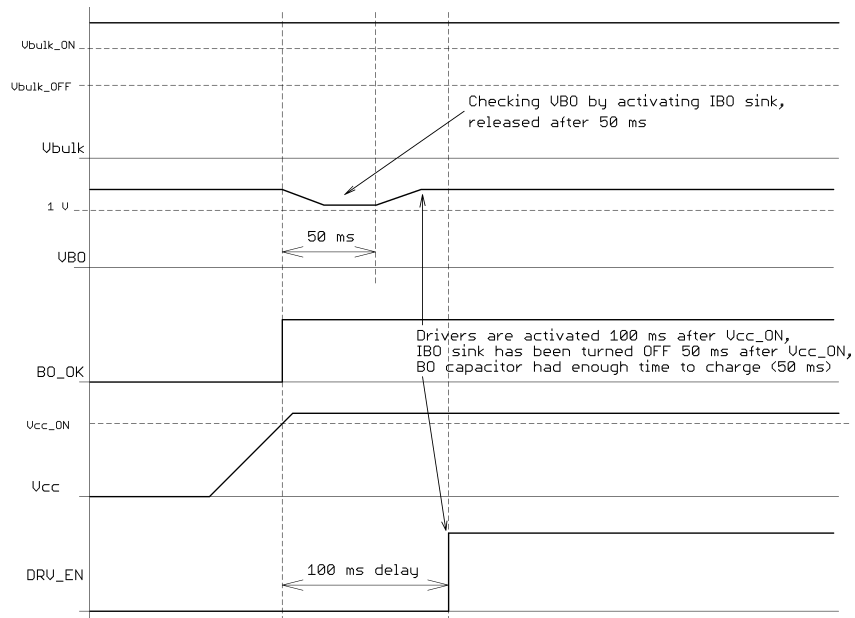

Figure 28. BO Input Functionality – $V_{bulk} > V_{bulk1}$

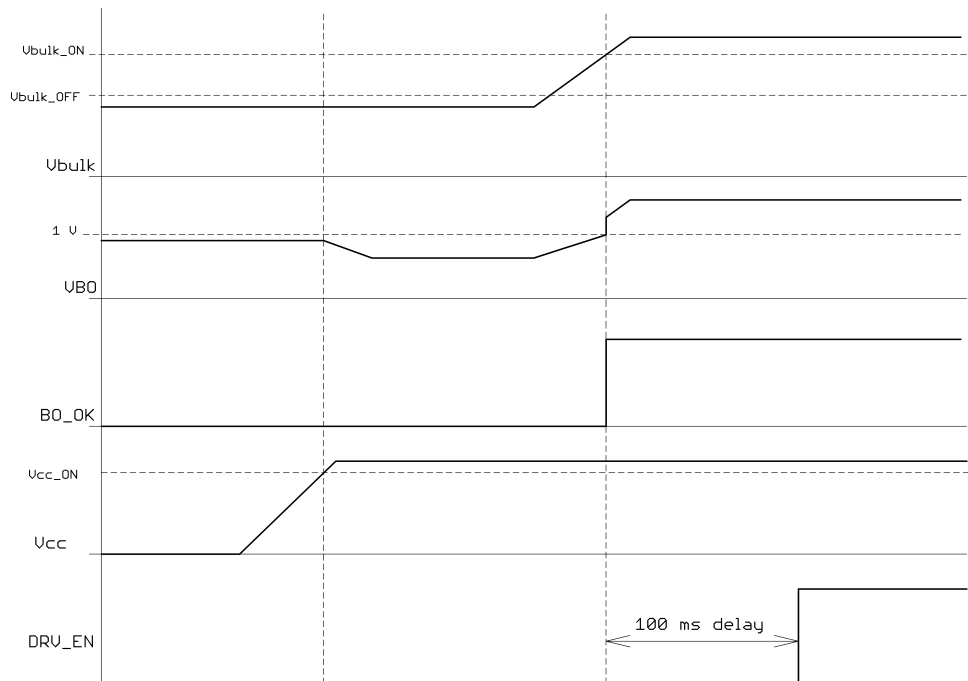

Figure 29. BO Input Functionality – $V_{bulk} < V_{bulk2}$, PFC Start Follows

Non-Latched Enable Input

The non-latched input stops output drivers immediately the BO terminal voltage grows above 2 V threshold. The enable comparator features 100 mV hysteresis so the BO terminal has to go down below 1.9 V to recover IC operation.

This input offers other features to the NCP1392 like dimming function for lamp ballasts (Figure 30) or skip mode capability for resonant converters (Figures 31 and 33).

NCP1392B

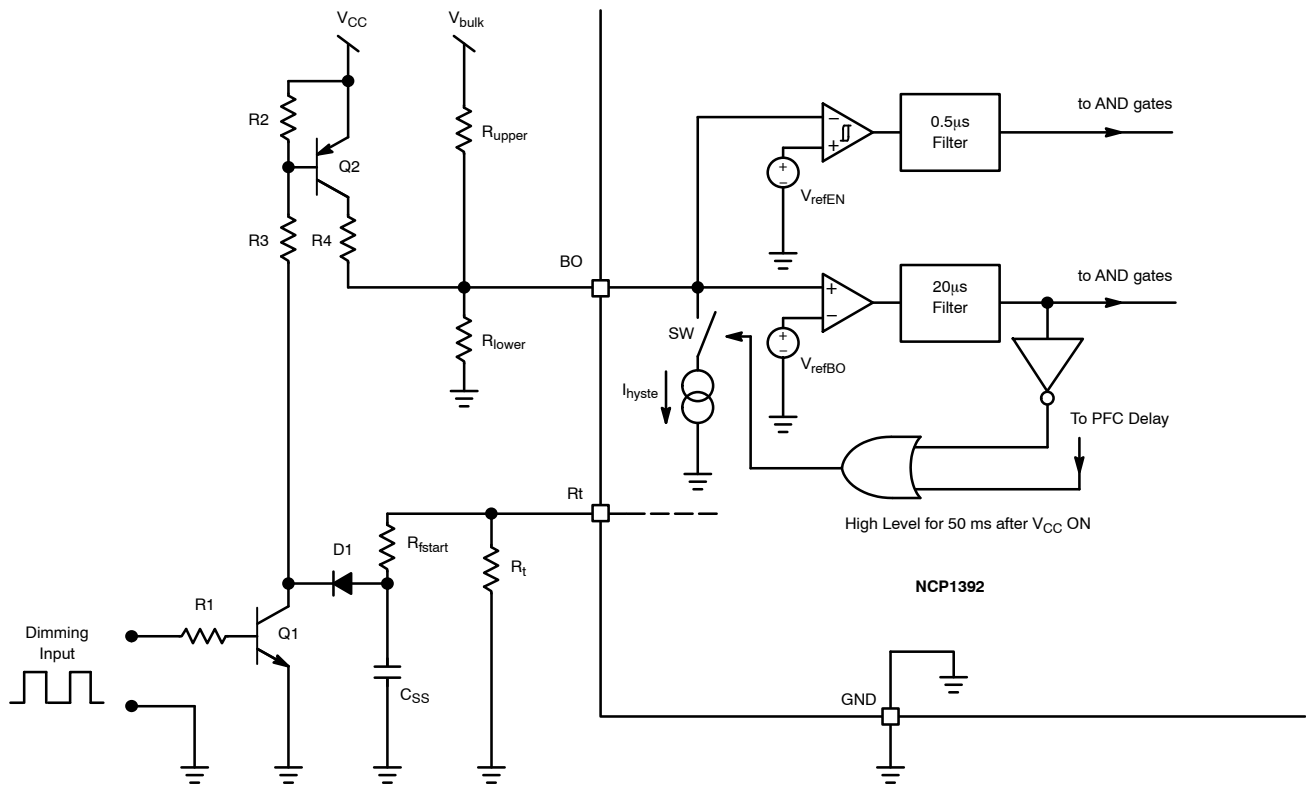

Figure 30. Dimming Feature Implementation Using Nonlatched Input on BO Terminal

The dimming feature can be easily aid to the ballast application by adding two bipolar transistors (Figure 14). Transistor Q2 pullup BO input when dimming signal is high.

In the same time the Q1 discharges soft start capacitor via diode D1. Ballast application is enabled (including soft-start phase) when dimming signal becomes low again.

NCP1392B

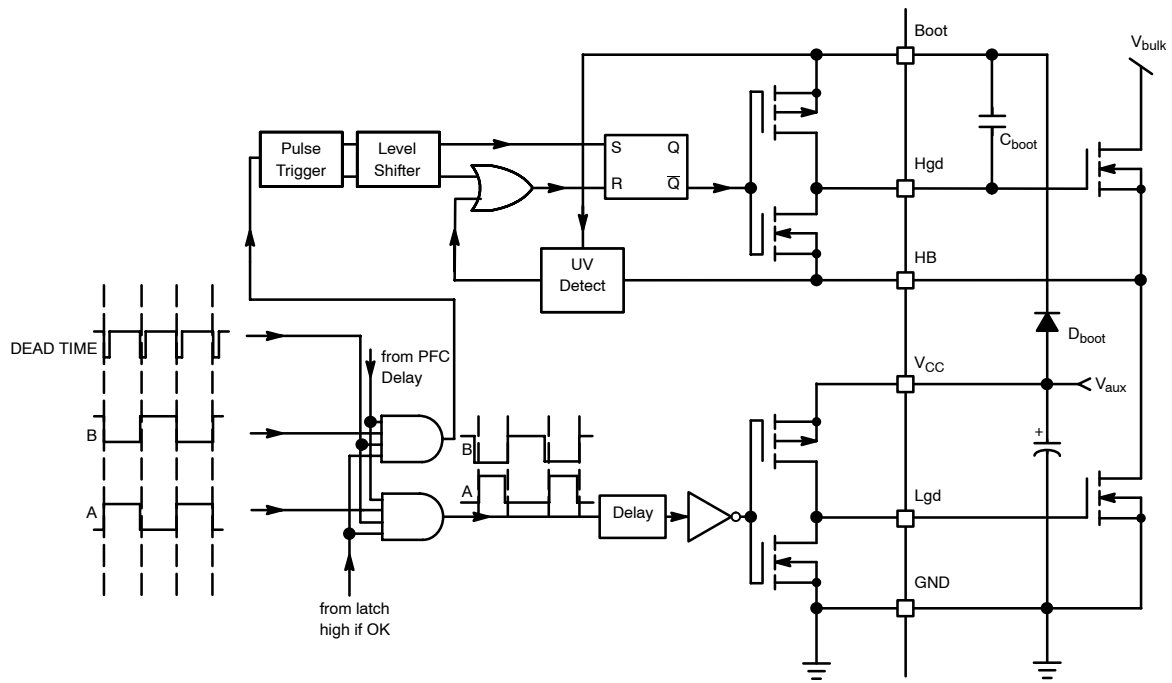

Figure 34. The Internal High-Voltage Section of the NCP1392

The A and B outputs are delivered by the internal logic, as depicted in block diagram. This logic is constructed in such a way that the Mlower driver starts to pulse first after any driver restart. The bootstrap capacitor is thus charged during first pulse. A delay is inserted in the lower rail to ensure good

matching between these propagating signals. As stated in the maximum rating section, the floating portion can go up to 600 Vdc and makes the IC perfectly suitable for offline applications featuring a 400 V PFC front-end stage.

NCP1392B

PACKAGE DIMENSIONS

SOIC-8 NB
CASE 751-07
ISSUE AJ

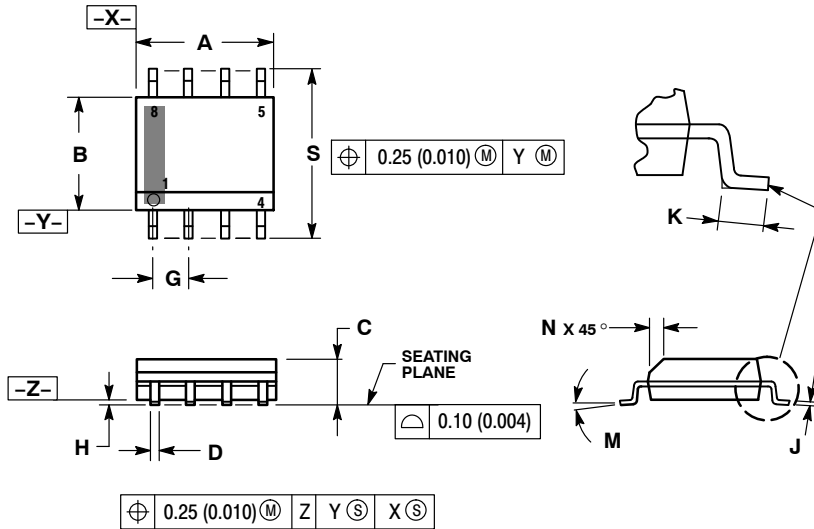

NOTES:

1. DIMENSIONING AND TOLERANCING PER ANSI Y14.5M, 1982.
2. CONTROLLING DIMENSION: MILLIMETER.
3. DIMENSION A AND B DO NOT INCLUDE MOLD PROTRUSION.
4. MAXIMUM MOLD PROTRUSION 0.15 (0.006) PER SIDE.
5. DIMENSION D DOES NOT INCLUDE DAMBAR PROTRUSION. ALLOWABLE DAMBAR PROTRUSION SHALL BE 0.127 (0.005) TOTAL IN EXCESS OF THE D DIMENSION AT MAXIMUM MATERIAL CONDITION.
6. 751-01 THRU 751-06 ARE OBSOLETE. NEW STANDARD IS 751-07.

DIM	MILLIMETERS		INCHES	
	MIN	MAX	MIN	MAX
A	4.80	5.00	0.189	0.197
B	3.80	4.00	0.150	0.157
C	1.35	1.75	0.053	0.069
D	0.33	0.51	0.013	0.020
G	1.27 BSC		0.050 BSC	
H	0.10	0.25	0.004	0.010
J	0.19	0.25	0.007	0.010
K	0.40	1.27	0.016	0.050
M	0°	8°	0°	8°
N	0.25	0.50	0.010	0.020
S	5.80	6.20	0.228	0.244

SOLDERING FOOTPRINT*

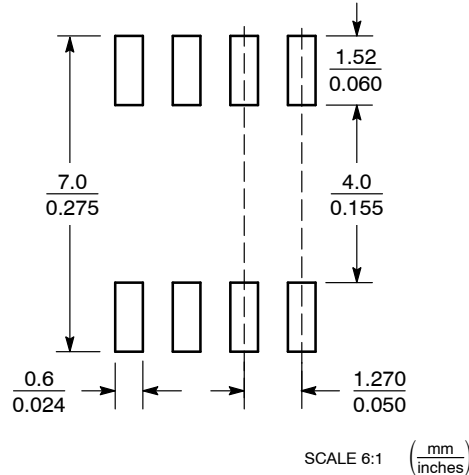

*For additional information on our Pb-Free strategy and soldering details, please download the ON Semiconductor Soldering and Mounting Techniques Reference Manual, SOLDERRM/D.

The products described herein (NCP1392/D), may be covered by one or more of the following U.S. patents; 6,097, 075; 7176723; 6,362, 067. There may be other patents pending.

ON Semiconductor and are registered trademarks of Semiconductor Components Industries, LLC (SCILLC). SCILLC reserves the right to make changes without further notice to any products herein. SCILLC makes no warranty, representation or guarantee regarding the suitability of its products for any particular purpose, nor does SCILLC assume any liability arising out of the application or use of any product or circuit, and specifically disclaims any and all liability, including without limitation special, consequential or incidental damages. "Typical" parameters which may be provided in SCILLC data sheets and/or specifications can and do vary in different applications and actual performance may vary over time. All operating parameters, including "Typicals" must be validated for each customer application by customer's technical experts. SCILLC does not convey any license under its patent rights nor the rights of others. SCILLC products are not designed, intended, or authorized for use as components in systems intended for surgical implant into the body, or other applications intended to support or sustain life, or for any other application in which the failure of the SCILLC product could create a situation where personal injury or death may occur. Should Buyer purchase or use SCILLC products for any such unintended or unauthorized application, Buyer shall indemnify and hold SCILLC and its officers, employees, subsidiaries, affiliates, and distributors harmless against all claims, costs, damages, and expenses, and reasonable attorney fees arising out of, directly or indirectly, any claim of personal injury or death associated with such unintended or unauthorized use, even if such claim alleges that SCILLC was negligent regarding the design or manufacture of the part. SCILLC is an Equal Opportunity/Affirmative Action Employer. This literature is subject to all applicable copyright laws and is not for resale in any manner.

PUBLICATION ORDERING INFORMATION

LITERATURE FULFILLMENT:
Literature Distribution Center for ON Semiconductor
P.O. Box 5163, Denver, Colorado 80217 USA
Phone: 303-675-2175 or 800-344-3860 Toll Free USA/Canada
Fax: 303-675-2176 or 800-344-3867 Toll Free USA/Canada
Email: orderlit@onsemi.com

N. American Technical Support: 800-282-9855 Toll Free USA/Canada
Europe, Middle East and Africa Technical Support:
Phone: 421 33 790 2910
Japan Customer Focus Center
Phone: 81-3-5773-3850

ON Semiconductor Website: www.onsemi.com
Order Literature: <http://www.onsemi.com/orderlit>

For additional information, please contact your local Sales Representative

NCP1392/D