



Date	DRN BY
8-25-09	MEA
MAT'L	SCALE
STEEL	NONE

TITLE	LARGER CHARGER CLIP
CURRENT RATING:	200 AMP

ISSUE NO.	0	1							
	8-25-09	9-15-09							

PART NO.	501849
PROJ. NO.	

This drawing is not to be disclosed to a third party without the authority from the company ©

FEDERAL SPEC : CID AA59466-014

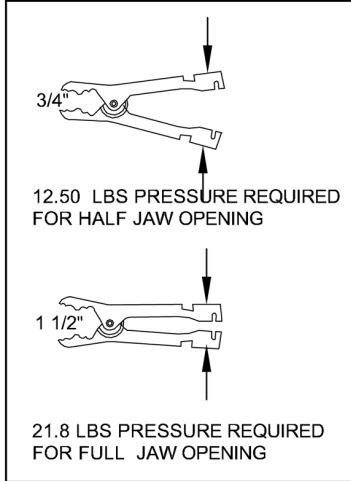

SPRING TESTED PER FED. SPEC. #WC440B FORCE APPLIED ON THE CENTER OF SPRING AXIS
FINISH: COPPER PLATED

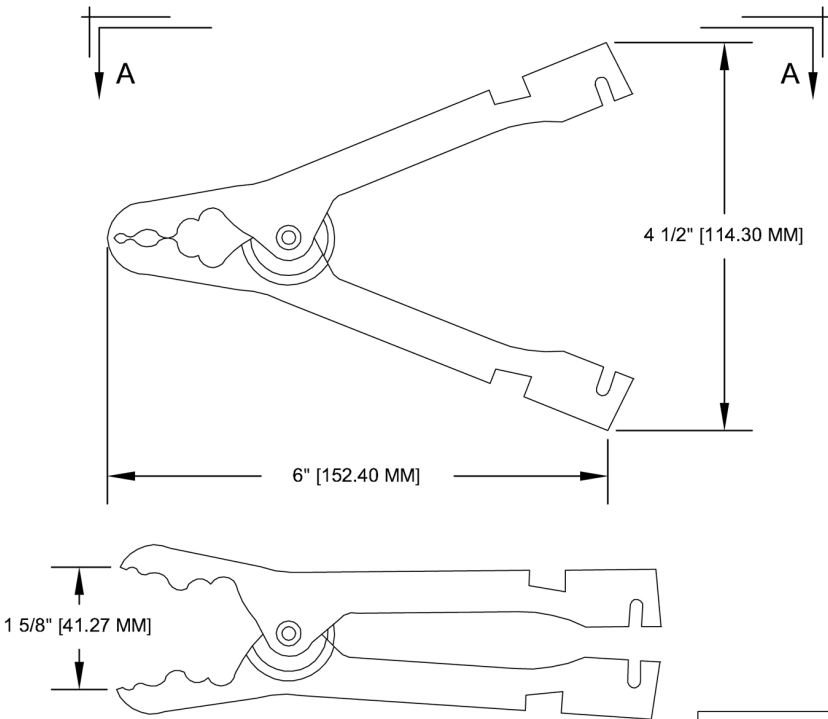

501849_B = 501849 CLIP & 400012_B INSULATORS INSTALLED
501849_R = 501849 CLIP & 400012_R INSULATORS INSTALLED

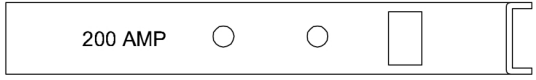
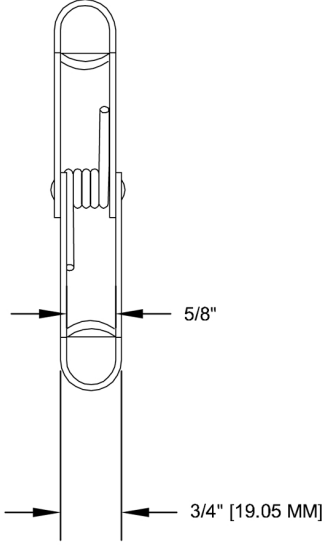

ASSEMBLY NO.	PACKAGING :	PRINTING AS ILLUSTRATED	CONCENTRICITY:	ANGLES
--------------	-------------	-------------------------	----------------	--------