



L2720/2/4

LOW DROP DUAL POWER OPERATIONAL AMPLIFIERS

- OUTPUT CURRENT TO 1 A
- OPERATES AT LOW VOLTAGES
- SINGLE OR SPLIT SUPPLY
- LARGE COMMON-MODE AND DIFFERENTIAL MODE RANGE
- LOW INPUT OFFSET VOLTAGE
- GROUND COMPATIBLE INPUTS
- LOW SATURATION VOLTAGE
- THERMAL SHUTDOWN
- CLAMP DIODE

DESCRIPTION

The L2720, L2722 and L2724 are monolithic integrated circuits in powerdip, minidip and SIP-9 packages, intended for use as power operational amplifiers in a wide range of applications including servo amplifiers and power supplies.

They are particularly indicated for driving, inductive loads, as motor and finds applications in compact-disc VCR automotive, etc.

The high gain and high output power capability provide superior performance whatever an operational amplifier/power booster combination is required.

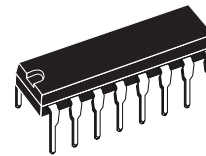

POWERDIP
(8 + 8)

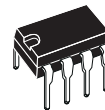

MINIDIP
(Plastic)

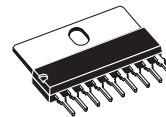

SIP9

ORDERING NUMBERS : L2720 (Powerdip)
L2722 (Minidip)
L2724 (SIP9)

PIN CONNECTIONS (top views)

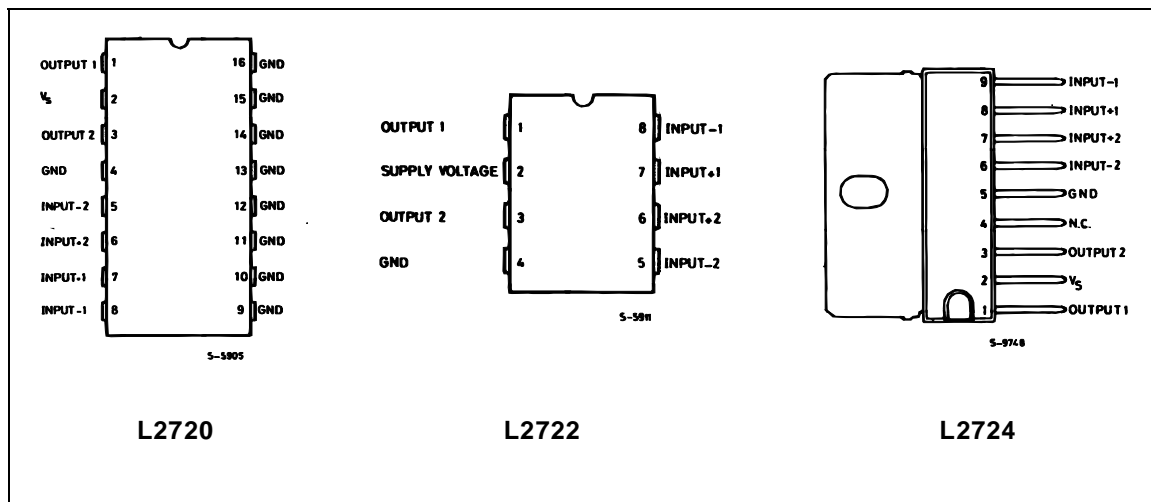

L2720/2/4

BLOCK DIAGRAM

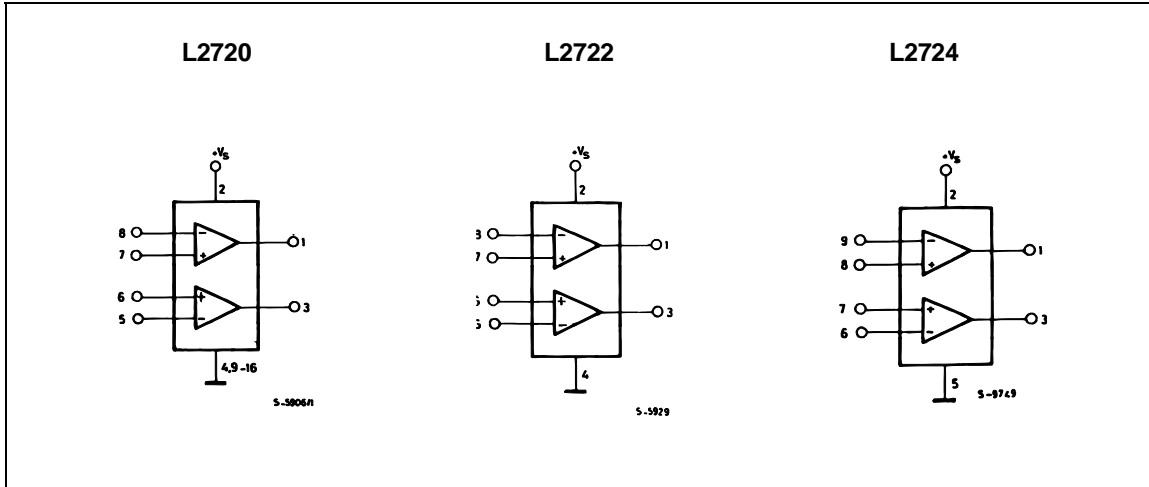

SCHEMATIC DIAGRAM (one section)

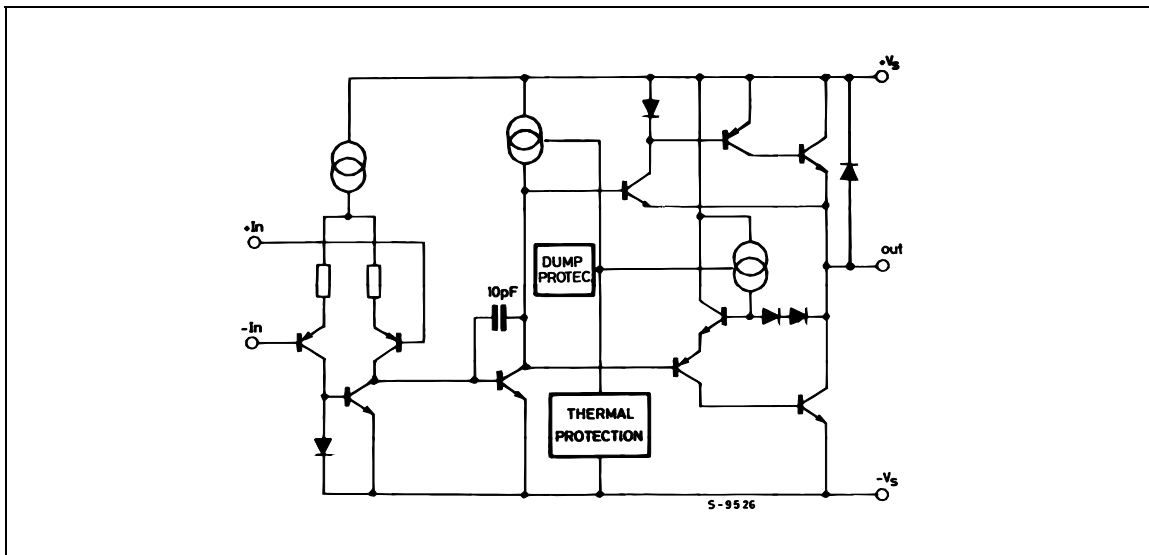

ABSOLUTE MAXIMUM RATINGS

Symbol	Parameter	Value	Unit
V_S	Supply Voltage	28	V
V_S	Peak Supply Voltage (50ms)	50	V
V_i	Input Voltage	V_S	
V_i	Differential Input Voltage	$\pm V_S$	
I_o	DC Output Current	1	A
I_p	Peak Output Current (non repetitive)	1.5	A
P_{tot}	Power Dissipation at $T_{amb} = 80^\circ\text{C}$ (L2720), $T_{amb} = 50^\circ\text{C}$ (L2722) $T_{case} = 75^\circ\text{C}$ (L2720) $T_{case} = 50^\circ\text{C}$ (L2724)	1 5 10	W
T_{stg}, T_j	Storage and Junction Temperature	-40 to 150	$^\circ\text{C}$

THERMAL DATA

			SIP-9	Powerdip	Minidip
$R_{th\ j-case}$	Thermal Resistance Junction-case	Max.	10°C/W	15°C/W	70°C/W
$R_{th\ j-amb}$	Thermal Resistance Junction-ambient	Max.	70°C/W	70°C/W	100°C/W

ELECTRICAL CHARACTERISTICS

$V_s = 24V$, $T_{amb} = 25^\circ C$ unless otherwise specified

Symbol	Parameter	Test Conditions	Min.	Typ.	Max.	Unit
V_s	Single Supply Voltage		4		28	V
V_s	Split Supply Voltage		± 2		± 14	V
I_s	Quiescent Drain Current	$V_o = \frac{V_s}{2}$ $V_s = 24V$ $V_s = 8V$		10 9	15 15	mA
I_b	Input Bias Current			0.2	1	μA
V_{os}	Input Offset Voltage				10	mV
I_{os}	Input Offset Current				100	nA
SR	Slew Rate			2		V/ μs
B	Gain-bandwidth Product			1.2		MHz
R_i	Input Resistance		500			k Ω
G_v	O.L. Voltage Gain	$f = 100Hz$ $f = 1kHz$	70	80 60		dB
e_N	Input Noise Voltage	$B = 22Hz$ to $22kHz$		10		μV
I_N	Input Noise Current			200		pA
CMR	Common Mode Rejection	$f = 1kHz$	66	84		dB
SVR	Supply Voltage Rejection	$f = 100Hz$ $R_G = 10k\Omega$ $V_R = 0.5V$ $V_s = 24V$ $V_s = \pm 12V$ $V_s = \pm 6V$	60	70 75 80		dB
$V_{DROP(HIGH)}$		$V_s = \pm 2.5V$ to $\pm 12V$ $I_p = 100mA$ $I_p = 500mA$		0.7 1	1.5	V
$V_{DROP(LOW)}$		$V_s = \pm 2.5V$ to $\pm 12V$ $I_p = 100mA$ $I_p = 500mA$		0.3 0.5	1	V
C_s	Channel Separation	$f = 1KHz$ $R_L = 10\Omega$ $G_v = 30dB$ $V_s = 24V$ $V_s = 6V$		60 60		dB
T_{sd}	Thermal Shutdown Junction Temperature			145		$^\circ C$

Figure 1 : Quiescent Current vs. Supply Voltage

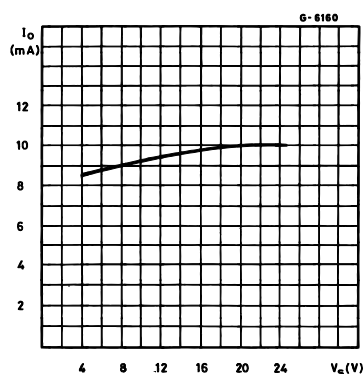
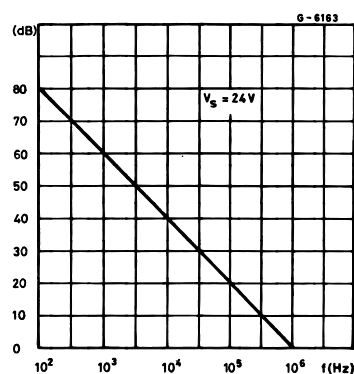
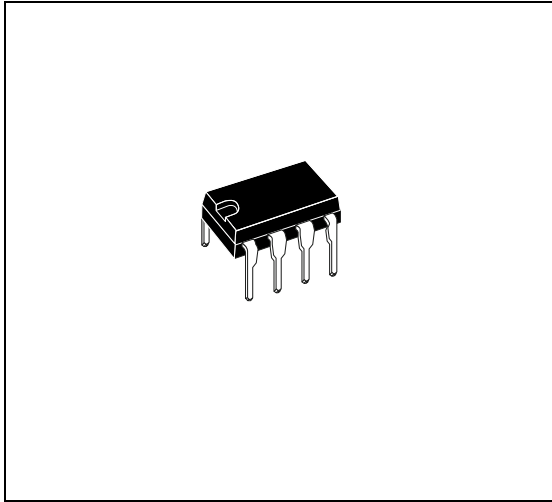

Figure 2 : Open Loop Gain vs. Frequency



DIM.	mm			inch		
	MIN.	TYP.	MAX.	MIN.	TYP.	MAX.
A		3.32			0.131	
a1	0.51			0.020		
B	1.15		1.65	0.045		0.065
b	0.356		0.55	0.014		0.022
b1	0.204		0.304	0.008		0.012
D			10.92			0.430
E	7.95		9.75	0.313		0.384
e		2.54			0.100	
e3		7.62			0.300	
e4		7.62			0.300	
F			6.6			0.260
I			5.08			0.200
L	3.18		3.81	0.125		0.150
Z			1.52			0.060

OUTLINE AND MECHANICAL DATA



Minidip

