

15 Amp - Industrial/Commercial Grade

1584 Series

Key Features

- Built to meet the rugged requirements of commercial and industrial use.
- All metal housing - tough extruded aluminum case with a black powder paint coated steel cover.
- Heavy duty receptacles.
- Heavy 14 gauge wire cord - 14/3 SJT or SJWT for extreme temperature ranges and integral molded plug.
- Plug types available are NEMA 5-15P straight blade or NEMA L5-15P twist-lock (see table below).
- Mounting feet (with keyhole slots) allow temporary work station mounting if desired.
- On-Off switch is rocker type with light (on those units with on-off switch - listed below) or a red pilot light to indicate power on.
- Includes 15 amp, 125 volt resettable circuit breaker to prevent accidental line overload.
- CSA certified, Standards C22.2 (No. 21-95 and No. 42-99)
- UL listed, Standard UL1363
- Surge Protected models also available - please see the 1584 "S" models on **page 25**



Outlet Strips



Part No.	Outlets	On-Off Switch	Pilot Light	Cord Length	Plug Type	Dimensions (inches)
1584H4A1	4	Yes	-	6'	Straight	11 x 2 x 2
1584H4B1	4	Yes	-	15'	Straight	11 x 2 x 2
1584H4C1	4	Yes	-	6'	Twist-Lock	11 x 2 x 2
1584H4D1	4	Yes	-	15'	Twist-Lock	11 x 2 x 2
1584H5A1	5	Yes	-	6'	Straight	14 x 2 x 2
1584H5B1	5	Yes	-	15'	Straight	14 x 2 x 2
1584H5C1	5	Yes	-	6'	Twist-Lock	14 x 2 x 2
1584H5D1	5	Yes	-	15'	Twist-Lock	14 x 2 x 2
1584H6A1	6	Yes	-	6'	Straight	14 x 2 x 2
1584H6B1	6	Yes	-	15'	Straight	14 x 2 x 2
1584H6C1	6	Yes	-	6'	Twist-Lock	14 x 2 x 2
1584H6D1	6	Yes	-	15'	Twist-Lock	14 x 2 x 2
1584H7A1	7	Yes	-	6'	Straight	17 x 2 x 2
1584H7B1	7	Yes	-	15'	Straight	17 x 2 x 2
1584H7C1	7	Yes	-	6'	Twist-Lock	17 x 2 x 2
1584H7D1	7	Yes	-	15'	Twist-Lock	17 x 2 x 2
1584H8A1	8	Yes	-	6'	Straight	17 x 2 x 2
1584H8B1	8	Yes	-	15'	Straight	17 x 2 x 2
1584H8C1	8	Yes	-	6'	Twist-Lock	17 x 2 x 2
1584H8D1	8	Yes	-	15'	Twist-Lock	17 x 2 x 2
1584T4A1	4	-	Yes	6'	Straight	11 x 2 x 2
1584T4B1	4	-	Yes	15'	Straight	11 x 2 x 2
1584T4C1	4	-	Yes	6'	Twist-Lock	11 x 2 x 2
1584T4D1	4	-	Yes	15'	Twist-Lock	11 x 2 x 2
1584T5A1	5	-	Yes	6'	Straight	14 x 2 x 2
1584T5B1	5	-	Yes	15'	Straight	14 x 2 x 2
1584T5C1	5	-	Yes	6'	Twist-Lock	14 x 2 x 2
1584T5D1	5	-	Yes	15'	Twist-Lock	14 x 2 x 2
1584T6A1	6	-	Yes	6'	Straight	14 x 2 x 2
1584T6B1	6	-	Yes	15'	Straight	14 x 2 x 2
1584T6C1	6	-	Yes	6'	Twist-Lock	14 x 2 x 2
1584T6D1	6	-	Yes	15'	Twist-Lock	14 x 2 x 2
1584T7A1	7	-	Yes	6'	Straight	17 x 2 x 2
1584T7B1	7	-	Yes	15'	Straight	17 x 2 x 2
1584T7C1	7	-	Yes	6'	Twist-Lock	17 x 2 x 2
1584T7D1	7	-	Yes	15'	Twist-Lock	17 x 2 x 2
1584T8A1	8	-	Yes	6'	Straight	17 x 2 x 2
1584T8B1	8	-	Yes	15'	Straight	17 x 2 x 2
1584T8C1	8	-	Yes	6'	Twist-Lock	17 x 2 x 2
1584T8D1	8	-	Yes	15'	Twist-Lock	17 x 2 x 2

Also Available (by special order) - change to a 90 degree Nema 5-15P plug on 1584 models ending in 'A1' or 'B1'.

NOTES

BUILT TO MEET THE REQUIREMENTS OF INDUSTRIAL AND COMMERCIAL USE. ALL METAL HOUSING—TOUGH EXTRUDED ALUMINUM CASE WITH BLACK POWDER-COATED STEEL COVER.
 HEAVY-DUTY CORD - 14/3 SJTW WIRE FOR EXTREME TEMPERATURE RANGES.
 INTEGRAL MOLDED PLUG AVAILABLE IN STRAIGHT-BLADE (NEMA 5-15P) OR TWIST-LOCK (NEMA L5-15P) CONFIGURATIONS.
 SEPARATE MOUNTING FEET WITH KEYHOLE SLOTS PROVIDE FOR WORK STATION MOUNTING IF DESIRED.
 COMES WITH LIGHTED RED PILOT LIGHT TO INDICATE POWER ON.
 INCLUDES 15A, 125VAC CIRCUIT BREAKER TO PREVENT ACCIDENTAL LINE OVERLOAD.
 CSA CERTIFIED, UL 1363 LISTED.

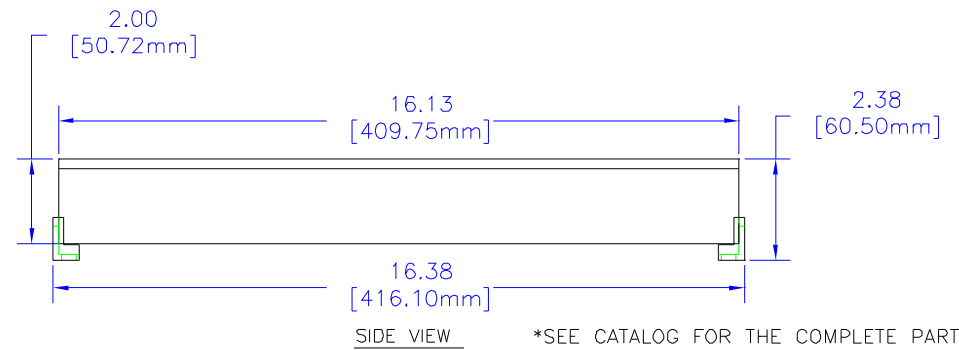
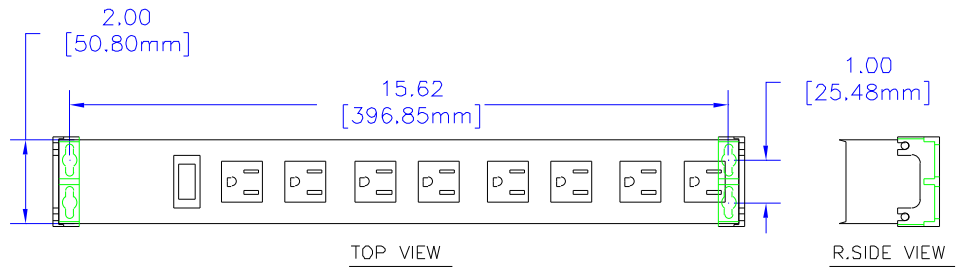

*SEE CATALOG FOR THE COMPLETE PART NUMBER BASED ON THE OPTIONS LISTED IN THE NOTE SECTION

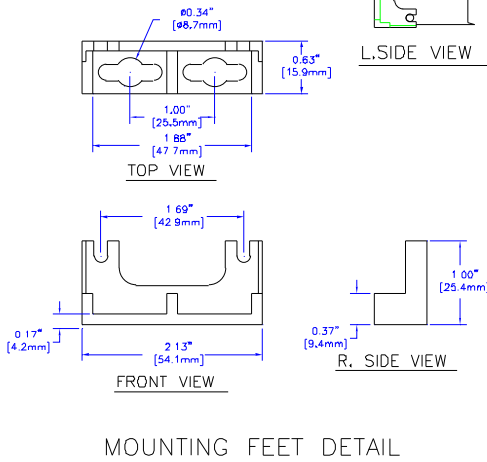

UNLESS OTHERWISE SPECIFIED
 DIMENSIONS ARE IN INCHES
 X +/- .1
 .XX +/- .05
 .XXX +/- .015
 .XXXX +/- .005
 ANGLES +/- .5 DEG.
 SURF FINISH UNLESS OTHERWISE SPECIFIED IS TO BE AS SHOWN ON THE DRAWING. IT IS INTENDED TO BE USED AS A REFERENCE FOR DIMENSIONING. REVISIONS TO THIS INFORMATION MAY NOT BE USED TO MANUFACTURE WITHOUT EXPRESS PERMISSION FROM HAMMOND MANUFACTURING.



HAMMOND MANUFACTURING

TITLE		HAMMOND INDUSTRIAL GRADE POWER STRIPS	
DRAWN BY	MJM	PAGE	1 OF 1
PART NUMBER	1584T8****		