

What is passive infrared type?

This sensor detects changes in infrared radiation which occur when there is movement by a person (or object) which is different in temperature from the surroundings.

- As this sensor detects temperature differences, it is well suited to detecting the motion of people by their body temperature.
- Wide sensing area.

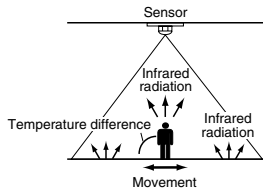

RoHS Directive compatibility information
<http://www.mew.co.jp/ac/e/environment/>

FEATURES

1. The world's smallest* with a built-in amplifier

Extremely compact. Ideal for use in miniaturized devices.

(*Based on our investigation as of November, 2006)

2. Dual lens colors (white and black) are available

With an ultrasmall design and dual lens colors (white and black), it is inconspicuous, allowing the user to select either white or black to match the equipment color. This provides greater flexibility in equipment design.

3. Both digital output and analog output (with adjustable sensitivity) are available.

Has a built-in amplifier, and can be connected directly to a microcomputer.

• Block diagram of the digital output circuit

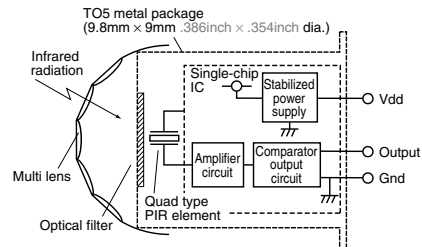

• Block diagram of the analog output circuit

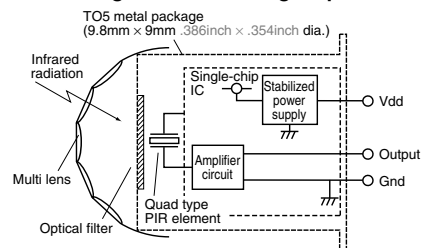

5. Detects even slight motion of a person

With our sensor, even slight motions made by people will be detected easily.

• Fine motion detection capability within approximately 2 meters of sensor.

Standard type:

Detects movement of approximately 30cm 11.811inch.

Slight motion detection type:

Detects movement of approximately 20cm 7.874inch.

6. Noise withstanding capability

Circuitry is contained in a TO5 metal package, providing at least twice the noise withstanding capability as conventional type.

• Comparison example of noise withstanding capability

	Distance at which motion sensor is not affected by cellular phone noise
Conventional type	Min. 1 to 2m 3.281 to 6.562ft
MP Motion Sensor	Min. 1 to 2cm .394 to .787inch

7. A low current consumption type (46 μA) has also been added to the lineup.

A type that keeps current consumption to 46 μA (less than 30% compared to predecessor) is now available. Ideal for battery driven devices.

*Digital output type only.

8. A more economically priced digital output type (ST type) has been launched.

APPLICATIONS

1. Home appliances

Useful for saving energy in air conditioner, television, personal computer, or ventilator and air purifier

2. Amusement machine market

Useful for saving energy and for automated guidance in theme parks and large video games

3. Equipment in service market

Useful for automated guidance, automated announcements and energy saving in vending machines, ATMs, etc.

4. Lighting market

Automated on/off controls, etc. for lamps, desk lamps, indoor lights, halls, stairway lights, etc.

ORDERING INFORMATION

		AMN				
Output				1		
2: Analog output	4: Low current consumption (digital output)					
3: Digital output (ST type)						
Detection performance						
1: Standard detection type	3: Spot detection type					
2: Slight motion detection type	4: 10m detection type					
Feature						
1: PC board mounting type						
Operating voltage						
1: 5V DC	2: 3V DC					
Lens color						
1: Black	2: White					

PRODUCT TYPES

1. Digital output

Rated operating voltage	Detection performance		Ambient temperature	Lens color	Part No.	Packing quantity	
						Inner	Outer
3 to 6 V DC 2.2 to 3 V DC (Low current consumption type)	Standard detection type	Standard	-20 to +60°C -4 to +140°F	Black	AMN31111	50 pcs.	1,000 pcs.
		Low current consumption		White	AMN31112		
	Slight motion detection type	Standard		Black	AMN41121		
				White	AMN41122		
		Low current consumption		Black	AMN32111		
				White	AMN32112		
	Spot detection type	Standard		Black	AMN42121		
				White	AMN42122		
				Black	AMN33111		
		Low current consumption		White	AMN33112		
				Black	AMN43121		
				White	AMN43122		
	10m detection type	Standard		Black	AMN34111		
				White	AMN34112		
		Low current consumption		Black	AMN44121		
				White	AMN44122		

2. Analog output

Rated operating voltage	Detection performance		Ambient temperature	Lens color	Part No.	Packing quantity	
						Inner	Outer
4.5 to 5.5 V DC	Standard detection type	-20 to +60°C -4 to +140°F	Black	AMN21111	50 pcs.	1,000 pcs.	
			White	AMN21112			
	Slight motion detection type		Black	AMN22111			
			White	AMN22112			
	Spot detection type		Black	AMN23111			
			White	AMN23112			
	10m detection type		Black	AMN24111			
			White	AMN24112			

PERFORMANCE

1. Detection performance

Items		Standard detection type	Slight motion detection type	Spot detection type	10m detection type	Conditions of objects to be detected
Rated detection distance <small>*Remark 1</small>		5m 16.404ft (Max.)	2m 6.562ft (Max.)	5m 16.404ft (Max.)	10m 32.808ft (Max.)	1. Detectable difference in temperature between the target and background for the spot type is more than 4°C 39.2°F. 2. Movement speed 1) Digital output type (ST type) • Standard detection type/Spot detection type/ 10m detection type: 0.8 to 1.2 m/s • Slight motion detection type: 0.5 m/s 2) Analog output and low current consumption types • Standard detection type/Spot detection type/ 10m detection type: 0.5 to 1.5 m/s • Slight motion detection type: 0.3 to 1.0 m/s 3. Detection object = human body (size is 700mm × 250mm 27.559inch × 9.843inch, but for the slight motion detection type the size is 200mm × 200mm 7.874inch × 7.874inch)
Detection range	Horizontal <small>*Remark 2</small>	100°	91°	38°	110°	
	Vertical <small>*Remark 2</small>	82°	91°	22°	93°	
Detection zone <small>*Remark 3</small>		64 zones	104 zones	24 zones	80 zones	

*Remarks 1. Depending on the difference in temperature between the background and detection target and the speed at which the target moves, these sensors may be capable of detection beyond the detection distances stated above. Nevertheless, they should be used within the prescribed detection distances. For further details, refer to the detection range diagram on page 25.

*Remarks 2.

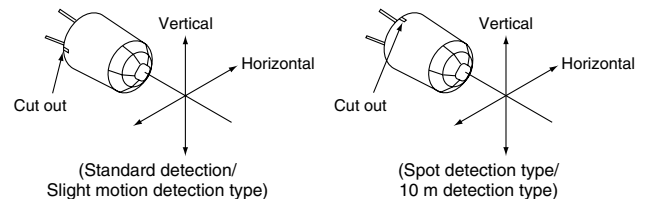

*Remarks 3. Regarding of detection zone, please refer to "DETECTION PERFORMANCE" on page 25.

2. Rating (Measuring condition: ambient temp. = 25°C 77°F) (Common to All types)

Items	Specified value	Remarks
Power supply voltage	-0.3 to 7 V DC	
Usable ambient temperature	-20 to 60°C -4 to +140°F	No freezing and condensing at low temperature.
Storage temperature	-20 to 70°C -4 to +158°F	

MP Motion Sensor (AMN2, 3, 4)

3. Electrical characteristics (Measuring condition: ambient temp. = 25°C 77°F; operating voltage = 5V) (Common to All types)

1) Digital output

Items		Symbol	Specified value		Measured conditions
			Standard type	Low current consumption type	
Rated operating voltage	Minimum	Vdd	3.0 V DC	2.2 V DC	
	Typical		—	—	
	Maximum		6.0 V DC	3.0 V DC	
Rated consumption current (Standby)*Remark		Typical	170 μA	46 μA	Iout = 0
		Maximum	300 μA	60 μA	
Output (when detecting)	Current	Maximum	100 μA	100 μA	Vout ≥ Vdd-0.5
	Voltage	Minimum	Vdd -0.5	Vdd -0.5	
		Maximum	—	—	Open when not detecting
Circuit stability time		Typical	7 s	7 s	
		Maximum	30 s	30 s	

Remark: The current which is consumed during detection consists of the standby consumed current plus the output current.

2) Analog output

Items		Symbol	Specified value	Measured conditions
Rated operating voltage	Minimum	Vdd	4.5 V DC	
	Maximum		5.5 V DC	
Rated consumption current		Typical	0.17 mA	Iout = 0
		Maximum	0.3 mA	
Output current		Maximum	50 μA	
Output voltage		Minimum	0 V	
		Typical	2.5 V	
		Maximum	Vdd	
Output offset average voltage		Minimum	2.3 V	Steady-state output voltage when not detecting
		Typical	2.5 V	
		Maximum	2.7 V	
Steady-state noise		Typical	155 m Vp-p	
		Maximum	300 m Vp-p	
Circuit stability time		Maximum	45 s	

Note: To set to the same detection performance as the digital type, set the output voltage to the offset voltage (2.5V) ±0.45V (i.e. 2.95V or more and 2.05V or less).

[Timing chart]

1) Digital output

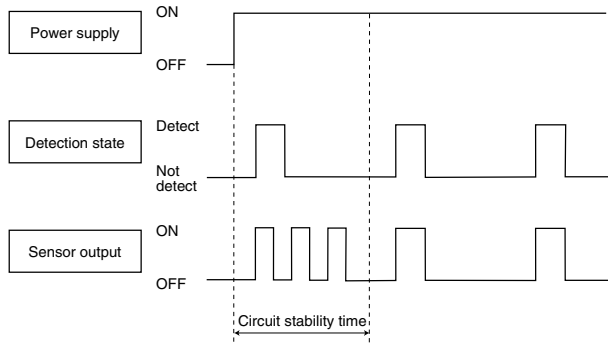

Remark:
Circuit stability time: 30s max.
While the circuitry is stabilizing after the power is turned on, the sensor output is not fixed in the "on" state or "off" state. This is true regardless of whether or not the sensor has detected anything.

2) Analog output

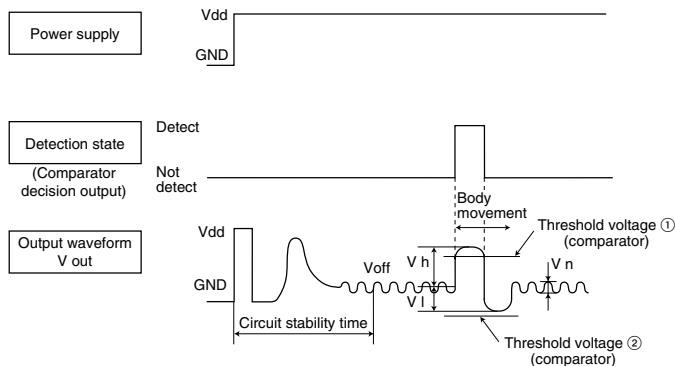

Remark:
Circuit stability time: 45s max.
While the circuitry is stabilizing after the power is turned on, the sensor output is not fixed in the "on" state or "off" state. This is true regardless of whether or not the sensor has detected anything.

DETECTION PERFORMANCE

1. Standard detection type

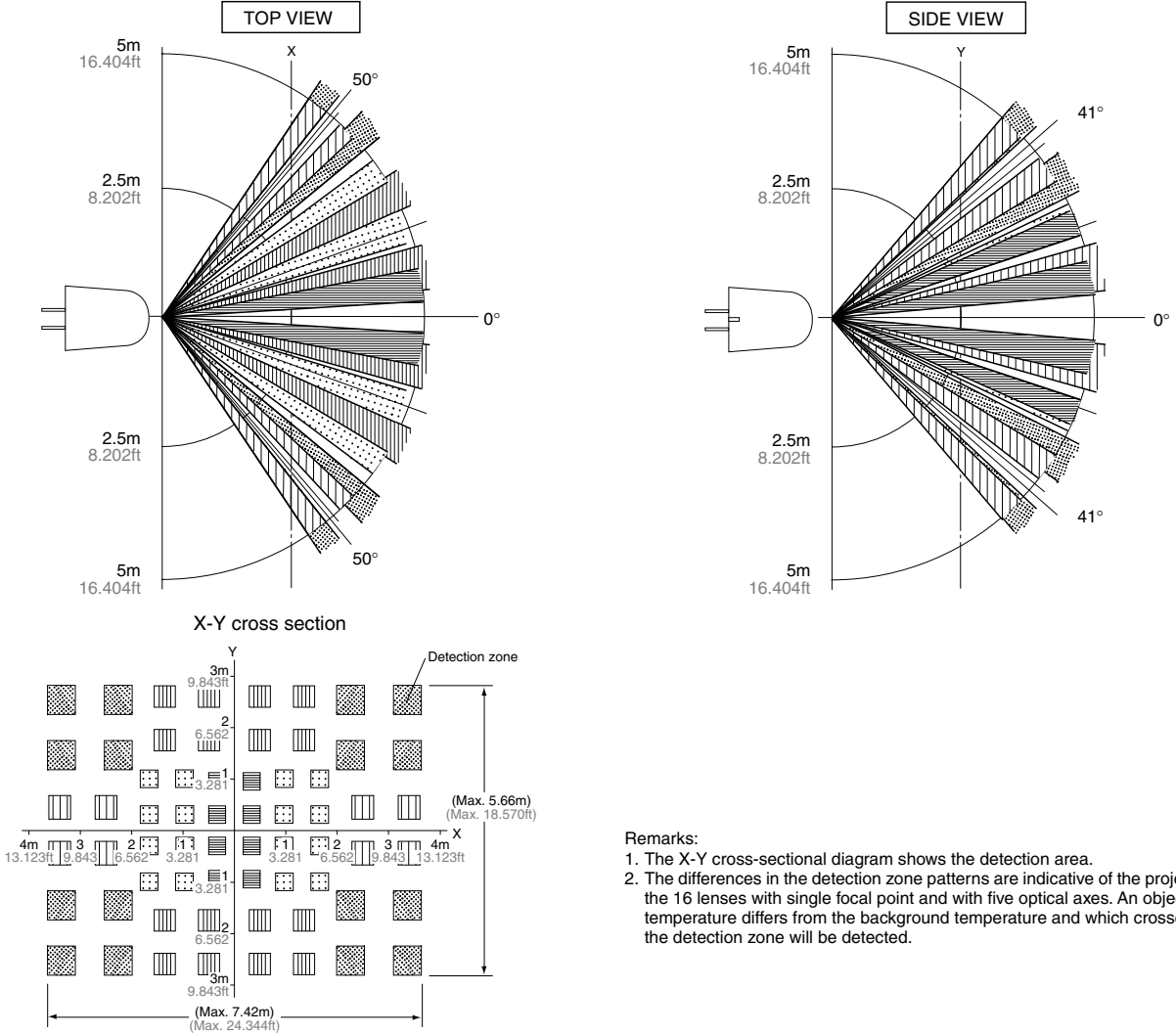

Remarks:

1. The X-Y cross-sectional diagram shows the detection area.
2. The differences in the detection zone patterns are indicative of the projections of the 16 lenses with single focal point and with five optical axes. An object whose temperature differs from the background temperature and which crosses inside the detection zone will be detected.

2. Slight motion detection type

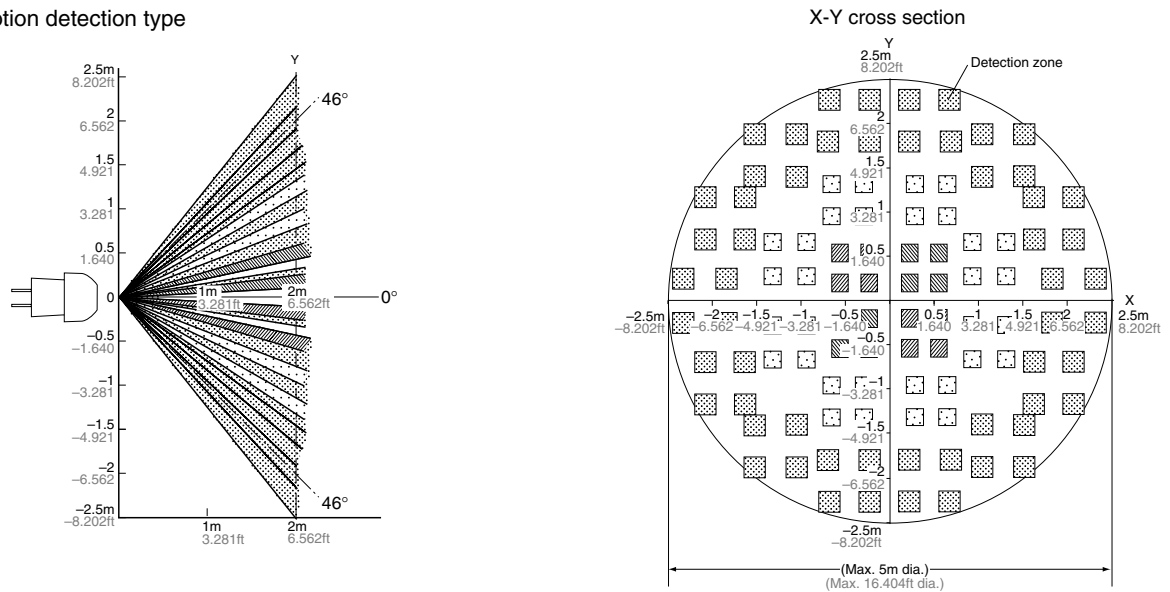

Remarks:

1. The X-Y cross-sectional diagram shows the detection area.
2. The differences in the detection zone patterns are indicative of the projections of the 26 lenses with single focal point and with three optical axes. An object whose

temperature differs from the background temperature and which crosses inside the detection zone will be detected.

MP Motion Sensor (AMN2, 3, 4)

3. Spot detection type

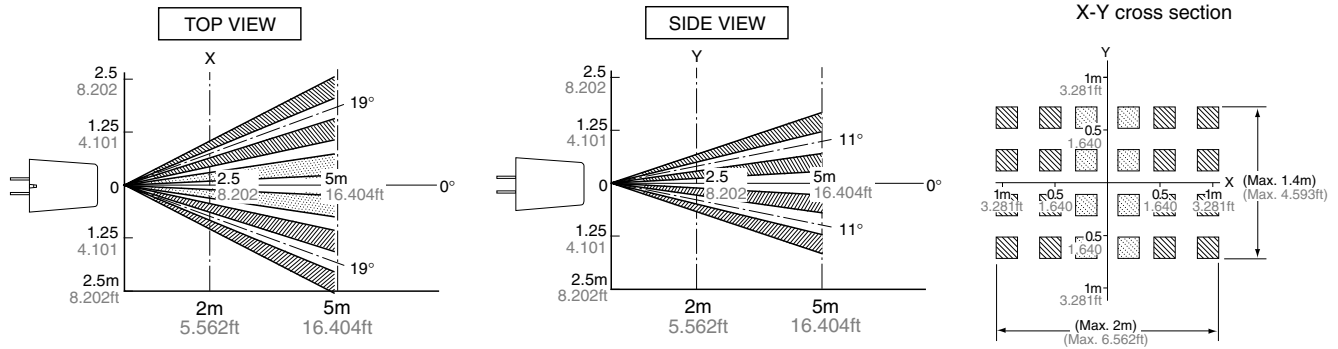

Remarks: 1. The X-Y cross-sectional diagram shows the detection area.
 2. The differences in the detection zone patterns are indicative of the projections of the 6 lenses with single focal point and with two optical axes.
 An object whose temperature differs from the background temperature and which crosses inside the detection zone will be detected.

4. 10m detection type

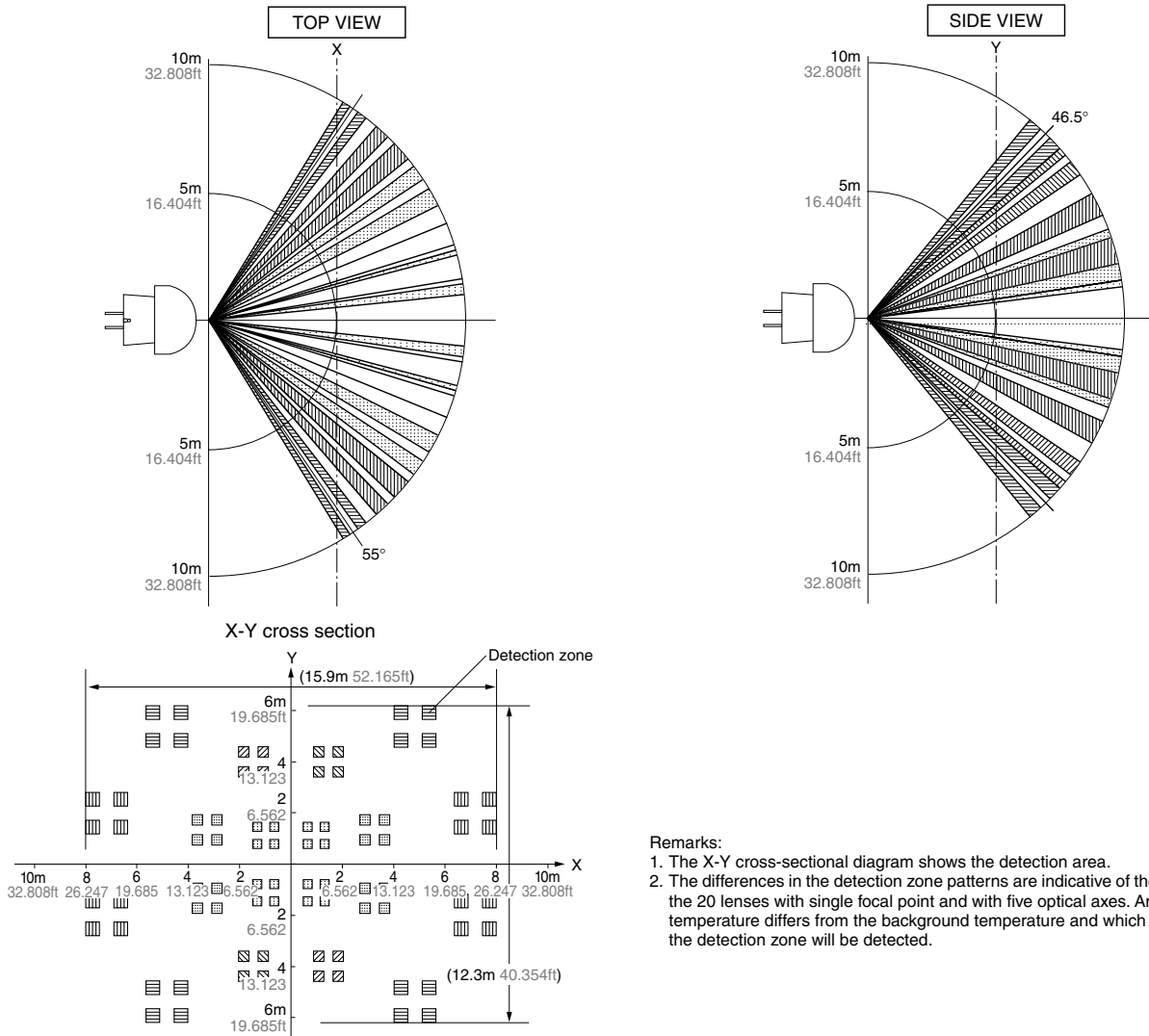

Remarks:
 1. The X-Y cross-sectional diagram shows the detection area.
 2. The differences in the detection zone patterns are indicative of the projections of the 20 lenses with single focal point and with five optical axes. An object whose temperature differs from the background temperature and which crosses inside the detection zone will be detected.

5. Notes regarding the detection zone

The detection zone has the polarity shown in the diagram on the right. When targets enter both the + and - zones with the same timing, the signals are cancelled each other, thus in this case there is a possibility that the object cannot be detected at the maximum specified detection distance.

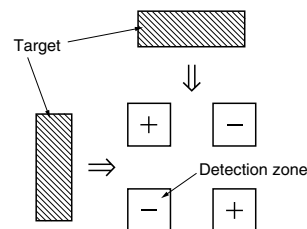

HOW TO USE

1. Wiring diagram

1) Digital output

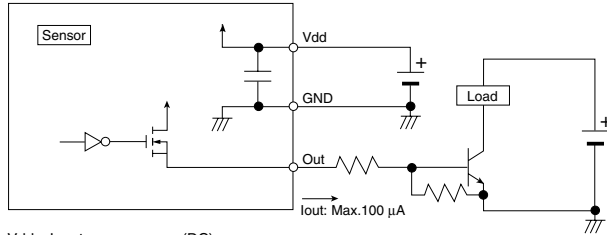

Vdd: Input power source (DC)
GND: GND
Out: Output (Comparator)

2) Analog output

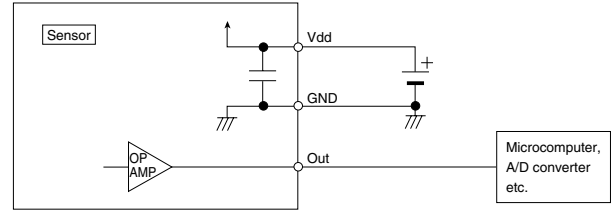

2. Timer circuit example

1) Digital output

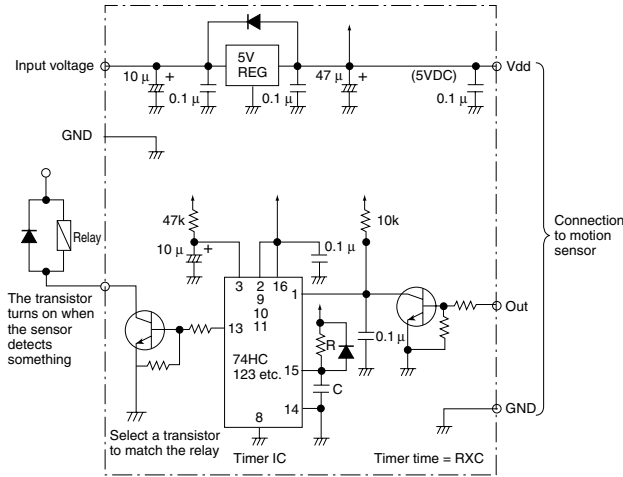

Note: This is the reference circuit which drives the MP motion sensor. Install a noise filter for applications requiring enhanced detection reliability and noise withstanding capability. Differences in the specifications of electronic components to which the units are connected sometimes affect their correct operation; please check the units' performance and reliability for each application.

2) Analog output

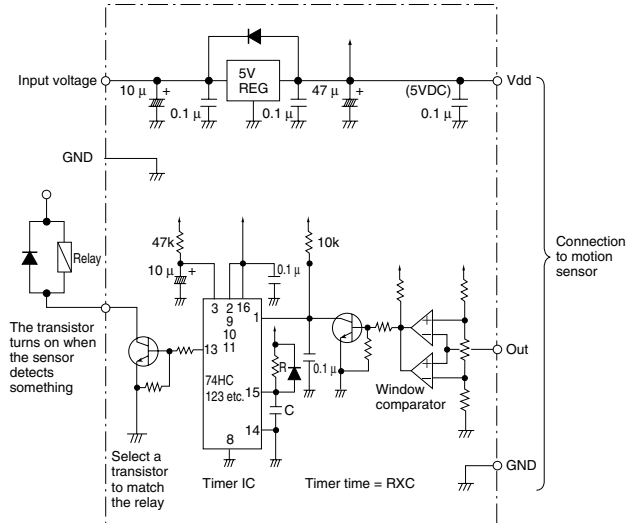

Note: This circuit is a sample of a drive circuit for the MP Motion Sensor. Its noise resistance and long-term reliability are not considered or investigated. To improve the detection reliability and noise resistance of the circuit, consider adding a noise filter. Matsushita Electric Works, Ltd. accepts no responsibility for damages resulting from the use of this circuit.

3. Installation

Install the sensor so that people will be entering from the X or Y direction shown below. If persons approach the sensor from the Z direction, detection distance will be shortened.

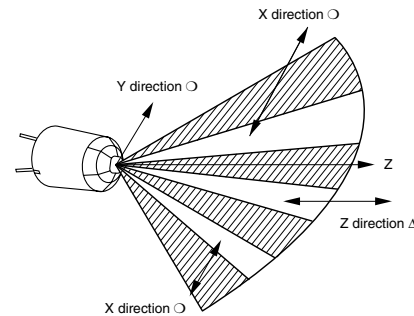

MP Motion Sensor (AMN2, 3, 4)

DIMENSIONS

mm inch General tolerance $\pm 0.5 \pm 0.20$

1. Standard detection type

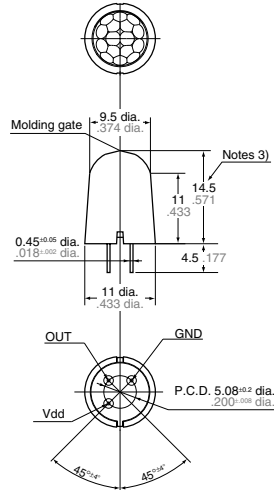

Recommended PC board pattern

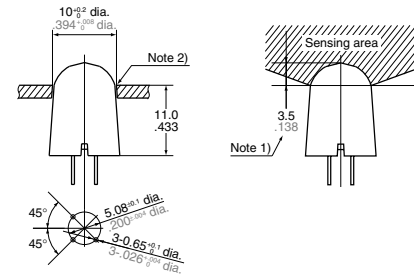

- Notes:
1. In order to ensure proper detection, install it with the lens exposed at least 3.5mm .138inch.
 2. As for panel mounting hole, tapering or making a large size hole should be done.
 3. The height dimension does not include the remaining molding gate.

2. Slight motion detection type

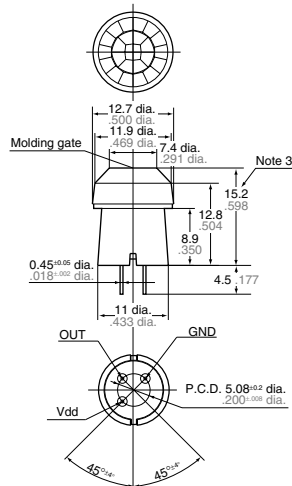

Recommended PC board pattern

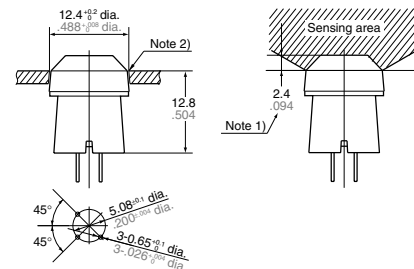

- Notes:
1. In order to ensure proper detection, install it with the lens exposed at least 2.4mm .094inch.
 2. As for panel mounting hole, tapering or making a large size hole should be done.
 3. The height dimension does not include the remaining molding gate.

3. Spot detection type

Recommended PC board pattern

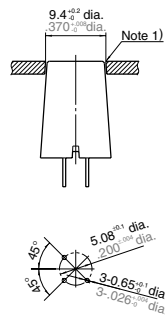
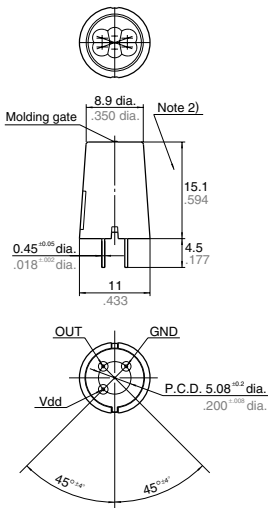

- Notes:
1. As for panel mounting hole, tapering or making a large size hole should be done.
 2. The height dimension does not include the remaining molding gate.

4. 10m detection type

Recommended PC board pattern

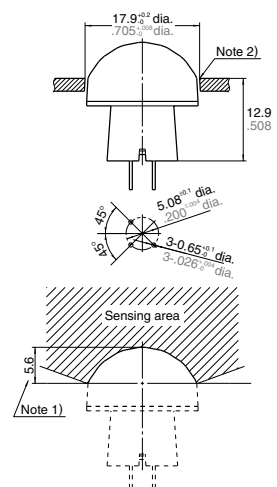
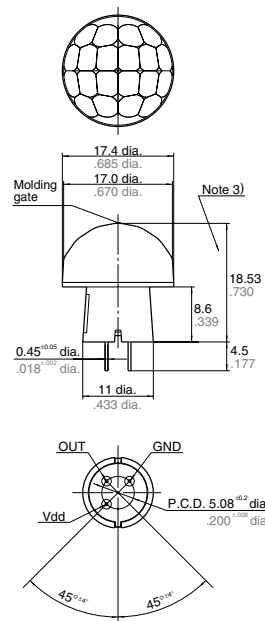

- Notes:
1. In order to ensure proper detection, install it with the lens exposed at least 5.6mm .220inch.
 2. As for panel mounting hole, tapering or making a large size hole should be done.
 3. The height dimension does not include the remaining molding gate.

NOTES

1. Checkpoints relating to principle of operation

MP motion sensors are passive infrared sensors which detect changes in the infrared rays. They may fail to detect successfully if a heat source other than a human being is detected or if there are no temperature changes in or movement of a heat source. Care must generally be taken in the following cases. The performance and reliability of the sensors must be checked out under conditions of actual use.

<1> Cases where a heat source other than a human being is detected.

- 1) When a small animal enters the detection range.
- 2) When the sensor is directly exposed to sunlight, a vehicle's headlights, an incandescent light or some other source of far infrared rays.
- 3) When the temperature inside the detection range has changed suddenly due to the entry of cold or warm air from an air-conditioning or heating unit, water vapor from a humidifier, etc.

<2> Cases where it is difficult to detect the heat source

- 1) When an object made of glass, acrylic or other subject which far infrared rays have difficulty passing through is located between the sensor and what is to be detected.
- 2) When the heat source inside the detection range hardly moves or when it moves at high speed; for details on the movement speed, refer to the section on the performance ratings.

2. When the detection area becomes larger

When the difference between the ambient temperature and body temperature is large (more than 20°C 68°F), detection may occur in isolated areas outside the specified detection range.

3. Other handling cautions

- 1) Be careful not to allow dust or dirt to accumulate on the lens as this will adversely affect the detection sensitivity.
- 2) The lens is made of a soft material (polyethylene). Avoid applying a load or impact since this will deform or scratch the lens, making proper operation impossible and causing a deterioration in its performance.

3) The sensor may be damaged if it is exposed to static with a voltage exceeding $\pm 200\text{V}$. Therefore, do not touch its terminals directly, and exercise adequate care in the handling of the sensor.

4) When the leads are to be soldered, solder them by hand for less than 3 seconds at a temperature of less than 350°C 662°F at the tip of the soldering iron. Avoid using a solder bath since this will causing a deterioration in the sensor's performance.

5) Do not attempt to clean the sensor. Cleaning fluid may enter inside the lens area causing a deterioration in performance.

6) When using the sensors with cables, it is recommended that cables which are shielded and as short as possible be used in order to safeguard against the effects of noise.

4. Ambient operating conditions

- 1) Temperature: Refer to the absolute maximum ratings for the temperature of each individual sensor.
- 2) Humidity: 15% to 85% RH (No freezing nor condensation at low temperature)
- 3) Atmospheric pressure: 86 to 106 kPa
- 4) Because the humidity range differs depending on the ambient temperature, the humidity range indicated below should be used. Continuous operation of the switch is possible within this range, but continuous use near the limit of the range should be avoided. This humidity range does not guarantee permanent performance.

<MP Motion Sensor>

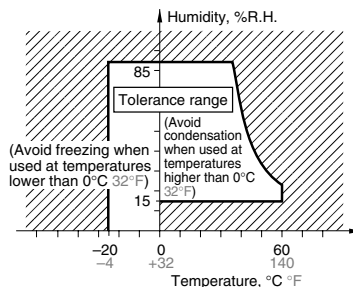

In general, degradation of electronic devices accelerates when they are operated under conditions of high temperature or high humidity. Before use, confirm the reliability of the sensors under the expected operating conditions.

5) When the sensor (especially for ST type) is used in noisy environments, connect a capacitor (approx. 1 μF) across its power input terminals and sensor output terminals.

6) The sensors do not have a water-proof or dust-proof construction. Depending on the ambient operating conditions, some means of providing protection from water and dust and preventing the formation of ice and condensation must be provided prior to using the sensors. If a sensor is used with a cover installed, the initial detection performance specifications may not be able to be met. Confirm the operation under the actual operating conditions.

7) Take care to avoid exposing the sensors to heat, vibration or impact since malfunctioning may result.

5. Concerning external surge voltages

Since the internal circuitry may be destroyed if an external surge voltages is supplied, provide an element which will absorb the surges. The levels of the voltage surges which the sensor can withstand is given below.

MP motion sensors: Within the supply voltage given in the absolute maximum ratings.

6. Concerning power supply-superimposed noise

Use a regulated power supply as the power supply. Otherwise, power supply-superimposed noise may cause the sensors to malfunction. The levels of noise which the sensor can withstand is given below.

MP motion sensors: $\pm 20\text{V}$ (50ns, 1 μs wide square waves)

7. Drop damage

If the sensor is dropped, damage can occur resulting in incorrect operation. If dropped, be sure to do a visual check of the exterior for noticeable damage and check the operation characteristics for faulty operation.

8. Concerning the circuit sides

Since the circuit sides given in this catalog are not protected in terms of circuit design, check out the performance and reliability of the circuits prior to using the sensors.