

MC14555B, MC14556B

Dual Binary to 1-of-4 Decoder/Demultiplexer

The MC14555B and MC14556B are constructed with complementary MOS (CMOS) enhancement mode devices. Each Decoder/Demultiplexer has two select inputs (A and B), an active low Enable input (E), and four mutually exclusive outputs (Q0, Q1, Q2, Q3). The MC14555B has the selected output go to the “high” state, and the MC14556B has the selected output go to the “low” state. Expanded decoding such as binary-to-hexadecimal (1-of-16), etc., can be achieved by using other MC14555B or MC14556B devices.

Applications include code conversion, address decoding, memory selection control, and demultiplexing (using the Enable input as a data input) in digital data transmission systems.

Features

- Diode Protection on All Inputs
- Active High or Active Low Outputs
- Expandable
- Supply Voltage Range = 3.0 Vdc to 18 Vdc
- All Outputs Buffered
- Capable of Driving Two Low-Power TTL Loads or One Low-Power Schottky TTL Load Over the Rated Temperature Range
- Pb-Free Packages are Available*

MAXIMUM RATINGS (Voltages Referenced to V_{SS})

| Parameter | Symbol | Value | Unit |
|---|-------------------|---------------------------|-------------|
| DC Supply Voltage Range | V_{DD} | -0.5 to +18.0 | V |
| Input or Output Voltage Range (DC or Transient) | V_{in}, V_{out} | -0.5 to V_{DD} + 0.5 | V |
| Input or Output Current (DC or Transient) per Pin | I_{in}, I_{out} | ± 10 | mA |
| Power Dissipation, per Package (Note 1) | P_D | 500 | mW |
| Ambient Temperature Range | T_A | -55 to +125 | $^{\circ}C$ |
| Storage Temperature Range | T_{stg} | -65 to +150 | $^{\circ}C$ |
| Lead Temperature (8-Second Soldering) | T_L | 260 | $^{\circ}C$ |

Stresses exceeding Maximum Ratings may damage the device. Maximum Ratings are stress ratings only. Functional operation above the Recommended Operating Conditions is not implied. Extended exposure to stresses above the Recommended Operating Conditions may affect device reliability.

1. Temperature Derating: Plastic “P and D/DW”

Packages: - 7.0 mW/ $^{\circ}C$ From 65 $^{\circ}C$ To 125 $^{\circ}C$

This device contains protection circuitry to guard against damage due to high static voltages or electric fields. However, precautions must be taken to avoid applications of any voltage higher than maximum rated voltages to this high-impedance circuit. For proper operation, V_{in} and V_{out} should be constrained to the range $V_{SS} \leq (V_{in} \text{ or } V_{out}) \leq V_{DD}$.

Unused inputs must always be tied to an appropriate logic voltage level (e.g., either V_{SS} or V_{DD}). Unused outputs must be left open.

*For additional information on our Pb-Free strategy and soldering details, please download the ON Semiconductor Soldering and Mounting Techniques Reference Manual, SOLDERRM/D.



ON Semiconductor®

MARKING DIAGRAMS

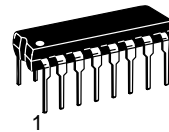

PDIP-16
P SUFFIX
CASE 648

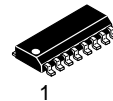

SOIC-16
D SUFFIX
CASE 751B

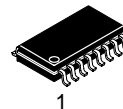

SOEIAJ-16
F SUFFIX
CASE 966



x = 5 or 6
A = Assembly Location
WL, L = Wafer Lot
YY, Y = Year
WW, W = Work Week
G = Pb-Free Package

PIN ASSIGNMENTS

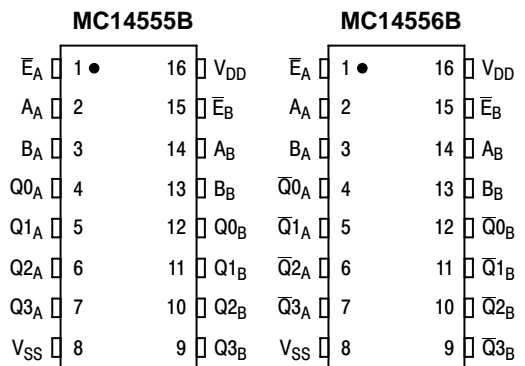

ORDERING INFORMATION

See detailed ordering and shipping information in the package dimensions section on page 4 of this data sheet.

MC14555B, MC14556B

TRUTH TABLE

| Inputs | | | Outputs | | | | | | | |
|--------|---|--------|----------|----|----|----|----------|----|----|----|
| Enable | | Select | MC14555B | | | | MC14556B | | | |
| E | B | A | Q3 | Q2 | Q1 | Q0 | Q3 | Q2 | Q1 | Q0 |
| 0 | 0 | 0 | 0 | 0 | 0 | 1 | 1 | 1 | 1 | 0 |
| 0 | 0 | 1 | 0 | 0 | 1 | 0 | 1 | 1 | 0 | 1 |
| 0 | 1 | 0 | 0 | 1 | 0 | 0 | 1 | 0 | 1 | 1 |
| 0 | 1 | 1 | 1 | 0 | 0 | 0 | 0 | 1 | 1 | 1 |
| 1 | X | X | 0 | 0 | 0 | 0 | 1 | 1 | 1 | 1 |

X = Don't Care

BLOCK DIAGRAM

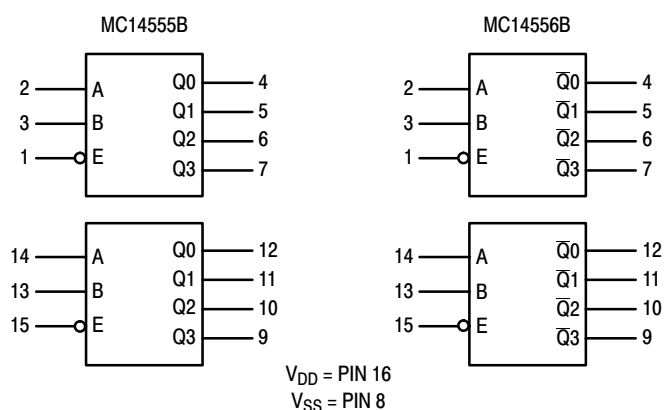

V_{DD} = PIN 16
V_{SS} = PIN 8

ELECTRICAL CHARACTERISTICS (Voltages Referenced to V_{SS})

| Characteristic | Symbol | V _{DD} Vdc | - 55°C | | 25°C | | | 125°C | | Unit |
|--|------------------------------|------------------------|--|------|-------|-----------------|------|-------|------|------|
| | | | Min | Max | Min | Typ (Note 2) | Max | Min | Max | |
| Output Voltage V _{in} = V _{DD} or 0 | “0” Level V _{OL} | 5.0 | – | 0.05 | – | 0 | 0.05 | – | 0.05 | Vdc |
| | | 10 | – | 0.05 | – | 0 | 0.05 | – | 0.05 | |
| V _{in} = 0 or V _{DD} | “1” Level V _{OH} | 5.0 | 4.95 | – | 4.95 | 5.0 | – | 4.95 | – | Vdc |
| | | 10 | 9.95 | – | 9.95 | 10 | – | 9.95 | – | |
| Input Voltage (V _O = 4.5 or 0.5 Vdc) (V _O = 9.0 or 1.0 Vdc) (V _O = 13.5 or 1.5 Vdc) | “0” Level V _{IL} | 5.0 | – | 1.5 | – | 2.25 | 1.5 | – | 1.5 | Vdc |
| | | 10 | – | 3.0 | – | 4.50 | 3.0 | – | 3.0 | |
| (V _O = 0.5 or 4.5 Vdc) (V _O = 1.0 or 9.0 Vdc) (V _O = 1.5 or 13.5 Vdc) | “1” Level V _{IH} | 5.0 | 3.5 | – | 3.5 | 2.75 | – | 3.5 | – | Vdc |
| | | 10 | 7.0 | – | 7.0 | 5.50 | – | 7.0 | – | |
| Output Drive Current (V _{OH} = 2.5 Vdc) (V _{OH} = 4.6 Vdc) (V _{OH} = 9.5 Vdc) (V _{OH} = 13.5 Vdc) | Source I _{OH} | 5.0 | –3.0 | – | –2.4 | –4.2 | – | –1.7 | – | mAdc |
| | | 5.0 | –0.64 | – | –0.51 | –0.88 | – | –0.36 | – | |
| (V _{OL} = 0.4 Vdc) (V _{OL} = 0.5 Vdc) (V _{OL} = 1.5 Vdc) | Sink I _{OL} | 10 | –1.6 | – | –1.3 | –2.25 | – | –0.9 | – | mAdc |
| | | 15 | –4.2 | – | –3.4 | –8.8 | – | –2.4 | – | |
| Input Current | I _{in} | 15 | – | ±0.1 | – | ±0.00001 | ±0.1 | – | ±1.0 | μAdc |
| Input Capacitance, (V _{in} = 0) | C _{in} | – | – | – | – | 5.0 | 7.5 | – | – | pF |
| Quiescent Current (Per Package) | I _{DD} | 5.0 | – | 5.0 | – | 0.005 | 5.0 | – | 150 | μAdc |
| | | 10 | – | 10 | – | 0.010 | 10 | – | 300 | |
| | | 15 | – | 20 | – | 0.015 | 20 | – | 600 | |
| Total Supply Current (Notes 3, 4) (Dynamic plus Quiescent, Per Package) (C _L = 50 pF on all outputs, all buffers switching) | I _T | 5.0 | I _T = (0.85 μA/kHz) f + I _{DD} I _T = (1.70 μA/kHz) f + I _{DD} I _T = (2.60 μA/kHz) f + I _{DD} | | | | | | | μAdc |
| | | 10 | | | | | | | | |
| | | 15 | | | | | | | | |

2. Data labelled “Typ” is not to be used for design purposes but is intended as an indication of the IC’s potential performance.

3. The formulas given are for the typical characteristics only at 25°C.

4. To calculate total supply current at loads other than 50 pF: I_T(C_L) = I_T(50 pF) + (C_L – 50) Vfk where: I_T is in μA (per package), C_L in pF, V = (V_{DD} – V_{SS}) in volts, f in kHz is input frequency, and k = 0.002.

MC14555B, MC14556B

SWITCHING CHARACTERISTICS (Note 5) ($C_L = 50 \text{ pF}$, $T_A = 25^\circ\text{C}$)

| Characteristic | Symbol | V_{DD} | Min | Typ (Note 6) | Max | Unit |
|---|--------------------|-----------------|-------------|-----------------|-------------------|------|
| Output Rise and Fall Time $t_{TLH}, t_{THL} = (1.5 \text{ ns/pF}) C_L + 25 \text{ ns}$ $t_{TLH}, t_{THL} = (0.75 \text{ ns/pF}) C_L + 12.5 \text{ ns}$ $t_{TLH}, t_{THL} = (0.55 \text{ ns/pF}) C_L + 9.5 \text{ ns}$ | t_{TLH}, t_{THL} | 5.0 10 15 | – – – | 100 50 40 | 200 100 80 | ns |
| Propagation Delay Time – A, B to Output $t_{PLH}, t_{PHL} = (1.7 \text{ ns/pF}) C_L + 135 \text{ ns}$ $t_{PLH}, t_{PHL} = (0.66 \text{ ns/pF}) C_L + 62 \text{ ns}$ $t_{PLH}, t_{PHL} = (0.5 \text{ ns/pF}) C_L + 45 \text{ ns}$ | t_{PLH}, t_{PHL} | 5.0 10 15 | – – – | 220 95 70 | 440 190 140 | ns |
| Propagation Delay Time – E to Output $t_{PLH}, t_{PHL} = (1.7 \text{ ns/pF}) C_L + 115 \text{ ns}$ $t_{PLH}, t_{PHL} = (0.66 \text{ ns/pF}) C_L + 52 \text{ ns}$ $t_{PLH}, t_{PHL} = (0.5 \text{ ns/pF}) C_L + 40 \text{ ns}$ | t_{PLH}, t_{PHL} | 5.0 10 15 | – – – | 200 85 65 | 400 170 130 | ns |

- The formulas given are for the typical characteristics only at 25°C .
- Data labelled "Typ" is not to be used for design purposes but is intended as an indication of the IC's potential performance.

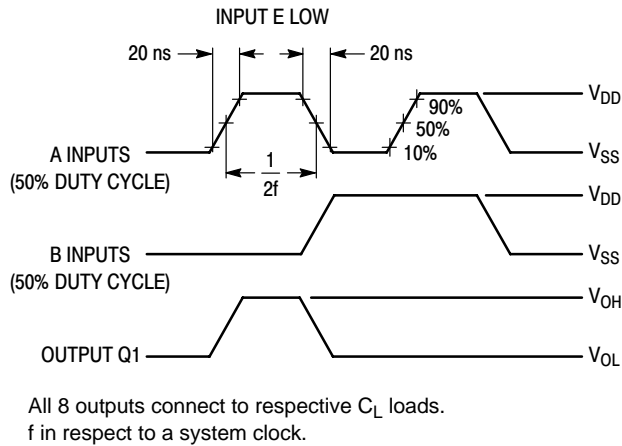

Figure 1. Dynamic Power Dissipation Signal Waveforms

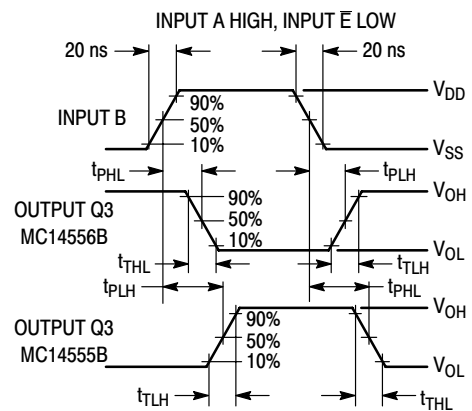
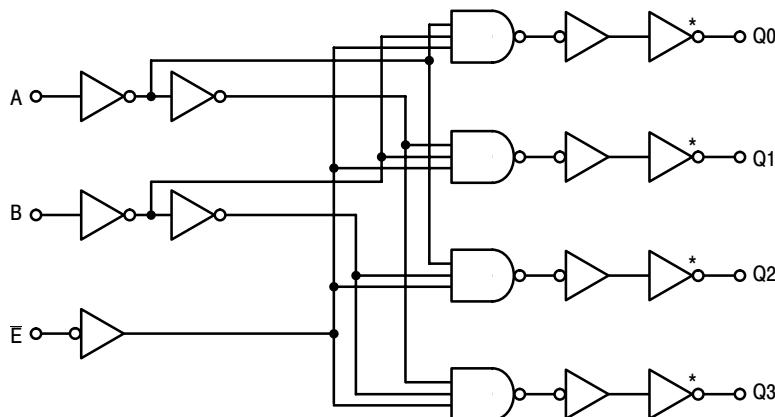

Figure 2. Dynamic Signal Waveforms

LOGIC DIAGRAM (1/2 of Dual)



*Eliminated for MC14555B

MC14555B, MC14556B

ORDERING INFORMATION

| Device | Package | Shipping† |
|--------------|------------------------|--------------------|
| MC14555BCP | PDIP-16 | 25 Units / Rail |
| MC14555BCPG | PDIP-16 (Pb-Free) | |
| MC14555BD | SOIC-16 | 48 Units / Rail |
| MC14555BDG | SOIC-16 (Pb-Free) | |
| MC14555BDR2 | SOIC-16 | 2500 / Tape & Reel |
| MC14555BDR2G | SOIC-16 (Pb-Free) | |
| MC14555BFEL | SOEIAJ-16 | 2000 / Tape & Reel |
| MC14555BFELG | SOEIAJ-16 (Pb-Free) | |
| MC14556BCP | PDIP-16 | 25 Units / Rail |
| MC14556BCPG | PDIP-16 (Pb-Free) | |
| MC14556BD | SOIC-16 | 48 Units / Rail |
| MC14556BDR2 | SOIC-16 | 2500 / Tape & Reel |
| MC14556BDR2G | SOIC-16 (Pb-Free) | |
| MC14556BF | SOEIAJ-16 | 50 Units / Tube |
| MC14556BFEL | SOEIAJ-16 | 2000 / Tape & Reel |
| MC14556BFELG | SOEIAJ-16 (Pb-Free) | |

†For information on tape and reel specifications, including part orientation and tape sizes, please refer to our Tape and Reel Packaging Specifications Brochure, BRD8011/D.

MC14555B, MC14556B

PACKAGE DIMENSIONS

PDIP-16
CASE 648-08
ISSUE T

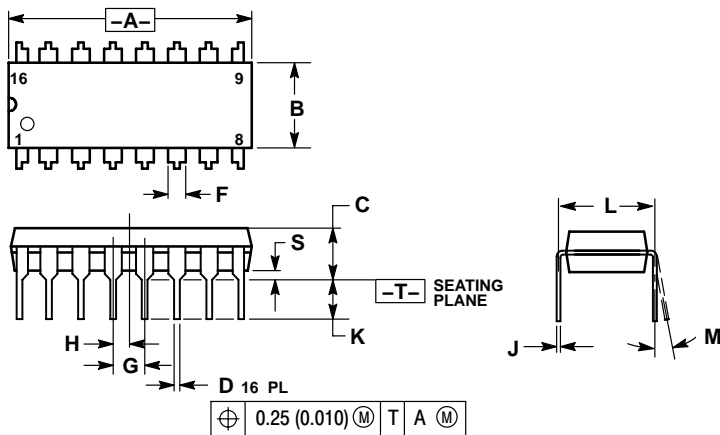

- NOTES:
1. DIMENSIONING AND TOLERANCING PER ANSI Y14.5M, 1982.
 2. CONTROLLING DIMENSION: INCH.
 3. DIMENSION L TO CENTER OF LEADS WHEN FORMED PARALLEL.
 4. DIMENSION B DOES NOT INCLUDE MOLD FLASH.
 5. ROUNDED CORNERS OPTIONAL.

| DIM | INCHES | | MILLIMETERS | |
|-----|-----------|-------|-------------|-------|
| | MIN | MAX | MIN | MAX |
| A | 0.740 | 0.770 | 18.80 | 19.55 |
| B | 0.250 | 0.270 | 6.35 | 6.85 |
| C | 0.145 | 0.175 | 3.69 | 4.44 |
| D | 0.015 | 0.021 | 0.39 | 0.53 |
| F | 0.040 | 0.70 | 1.02 | 1.77 |
| G | 0.100 BSC | | 2.54 BSC | |
| H | 0.050 BSC | | 1.27 BSC | |
| J | 0.008 | 0.015 | 0.21 | 0.38 |
| K | 0.110 | 0.130 | 2.80 | 3.30 |
| L | 0.295 | 0.305 | 7.50 | 7.74 |
| M | 0° | 10° | 0° | 10° |
| S | 0.020 | 0.040 | 0.51 | 1.01 |

SOIC-16
CASE 751B-05
ISSUE J

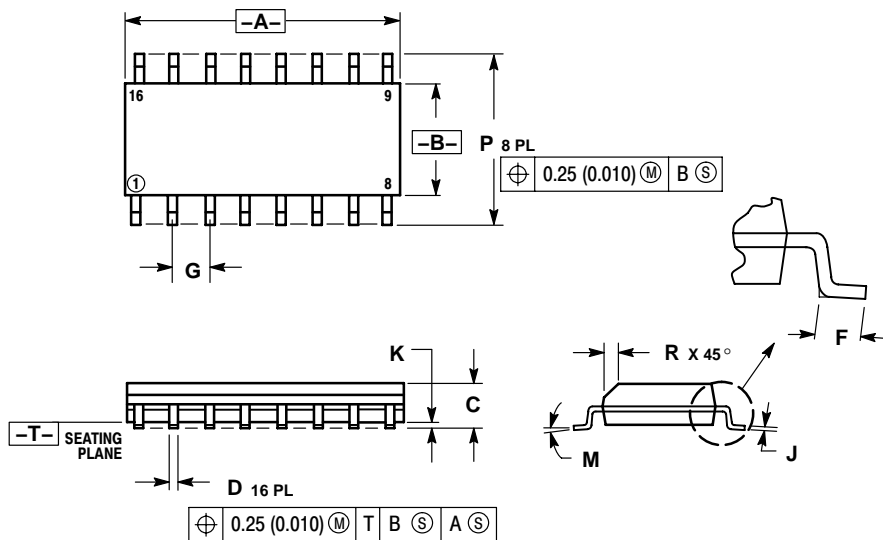

- NOTES:
1. DIMENSIONING AND TOLERANCING PER ANSI Y14.5M, 1982.
 2. CONTROLLING DIMENSION: MILLIMETER.
 3. DIMENSIONS A AND B DO NOT INCLUDE MOLD PROTRUSION.
 4. MAXIMUM MOLD PROTRUSION 0.15 (0.006) PER SIDE.
 5. DIMENSION D DOES NOT INCLUDE DAMBAR PROTRUSION. ALLOWABLE DAMBAR PROTRUSION SHALL BE 0.127 (0.005) TOTAL IN EXCESS OF THE D DIMENSION AT MAXIMUM MATERIAL CONDITION.

| DIM | MILLIMETERS | | INCHES | |
|-----|-------------|-------|-----------|-------|
| | MIN | MAX | MIN | MAX |
| A | 9.80 | 10.00 | 0.386 | 0.393 |
| B | 3.80 | 4.00 | 0.150 | 0.157 |
| C | 1.35 | 1.75 | 0.054 | 0.068 |
| D | 0.35 | 0.49 | 0.014 | 0.019 |
| F | 0.40 | 1.25 | 0.016 | 0.049 |
| G | 1.27 BSC | | 0.050 BSC | |
| J | 0.19 | 0.25 | 0.008 | 0.009 |
| K | 0.10 | 0.25 | 0.004 | 0.009 |
| M | 0° | 7° | 0° | 7° |
| P | 5.80 | 6.20 | 0.229 | 0.244 |
| R | 0.25 | 0.50 | 0.010 | 0.019 |