

PMOLED display power supply

Features

- Inductor switches boost controller
- PFM mode control
- High efficiency over wide range of load (1 mA to 40 mA)
- Integrated load disconnect switch
- Over voltage protection with automatic restart
- Soft start with adjustable peak current limit
- Enable pin
- Low shutdown current
- Small external inductor
- Supply voltage from 3.0 V to 5.5 V

Application

- PMOLED display driver

Description

STOD2540 is dedicated to passive matrix OLED (PMOLED) displays for portable handsets and provides the pre-charge and biasing voltage of the column matrix driver as shown in figure 3. The current capability of STOD2540 allows feeding a 1", 1.3" or 1.5" color PMOLED. STOD2540 is a boost converter that operates from 3.0 V to 5.5 V and can provide an output voltage as high as 25 V. The output current capability is maximum 40 mA up to 25 V output voltage. The regulation is performed by a resistor divider network (figure 3) that detects the output voltage.

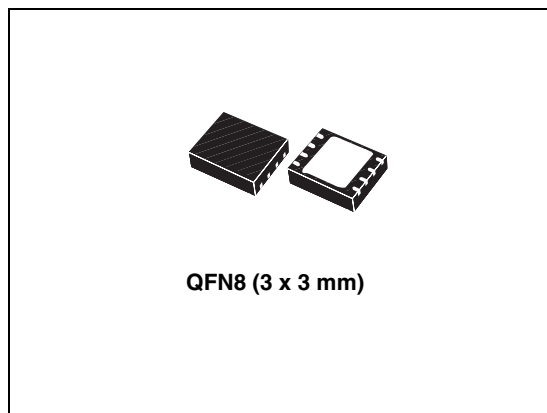

In this state-of-the-art boost converter, a DC current path exists between the battery source and the load. In order to reduce the consumption in shutdown mode, a high-side load isolation switch is necessary to cut this DC current path in standby mode. The load disconnect switch (LDS) act as an isolation switch in shutdown mode.

Table 1. Device summary

Order code	Package	Packaging
STOD2540PUR	QFN8 (3 x 3 mm)	3000 parts per reel

Contents

1	Diagram	3
2	Pin configuration	4
3	Maximum ratings	5
4	Electrical characteristics	6
5	Functional description	8
	5.1 Boost controller	8
	5.2 Adjustable peak inductor current limit	8
	5.3 Enable	8
	5.4 OVP	8
	5.5 Load isolation switch	9
	5.6 Efficiency	9
	5.7 Under voltage lockout (UVLO)	9
6	Typical application	10
	6.1 Demonstration board	11
7	Typical performance characteristics	12
8	Package mechanical data	15
9	Revision history	19

2 Pin configuration

Figure 2. Pin connections (top through view)

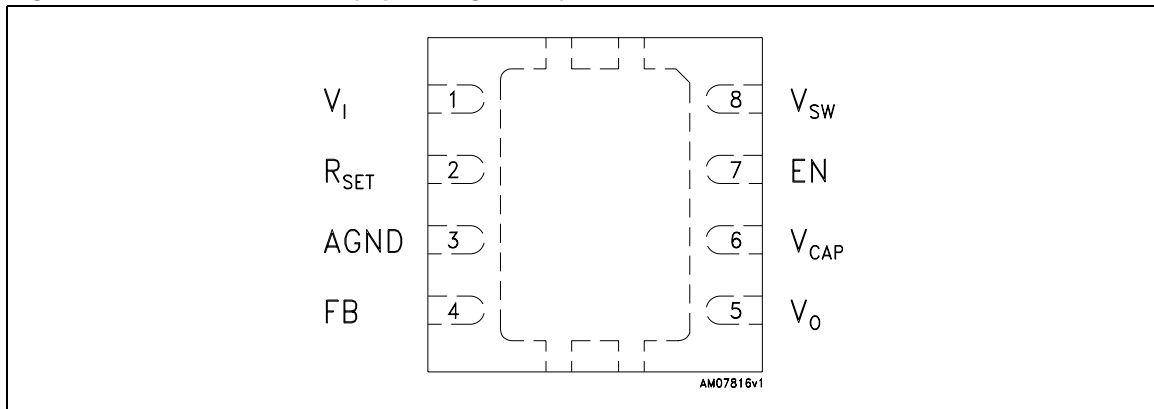

Table 2. Pin description

Pin n°	Symbol	Note
1	V_I	Supply voltage
2	R_{SET}	Peak inductor current adjust
3	AGND	Analog ground
4	FB	Feedback for the LED current regulation
5	V_O	Output voltage for LED supply
6	V_{CAP}	Load disconnect switch input
7	EN	IC enable signal
8	V_{SW}	Boost switch drain
	PGND	Power ground

3 Maximum ratings

Table 3. Absolute maximum ratings

Symbol	Parameter	Value	Unit
V_{BSW}, V_{BO}	Breakdown voltage at OUT and SW pin	40	V
V_I	Supply voltage range	6	V
R_{SET}	R_{SET} pin	$V_I + 0.3$	V
EN	Enable pin	$V_I + 0.3$	V
V_{ESD}	ESD ratings, HBM MIL STD 883C	2	kV
T_{STG}	Storage temperature range	- 65 to 150	°C
T_{OP}	Operating junction temperature range	- 40 to 85	°C

Table 4. Thermal data

Symbol	Parameter	Value	Unit
R_{thJA}	Thermal resistance junction-ambient	52	°C/W

4 Electrical characteristics

$T_J = 40\text{ }^\circ\text{C}$ to $85\text{ }^\circ\text{C}$, $V_I = 3.6\text{ V}$, $V_{EN} = 3\text{ V}$, $C_1 = C_O = 4.7\text{ }\mu\text{F}$, $L = 4.7\text{ }\mu\text{H}$, $R_1 = 180\text{ k}\Omega$, $R_2 = 10\text{ k}\Omega$, $V_O = 24\text{ V}$, Typ. values @ $25\text{ }^\circ\text{C}$, unless otherwise specified.

Table 5. Electrical characteristics

Symbol	Parameter	Test condition	Min.	Typ.	Max.	Unit
V_I	Input voltage range		3.0		5.5	V
V_O	Regulated output voltage	$V_I = 3\text{ V}$ to 5.5 V	$V_I + 0.5$	25	35	V
V_{OVP}	Over voltage protection on output		35			V
I_O	Continuous output current	$V_O = 25\text{ V}$	1		40	mA
I_{SD}	Stand-by current	$V_{EN} = \text{Low}$, $V_I = 3.6\text{ V}$			3	μA
		$V_{EN} = \text{Low}$, $V_I = 3\text{ V}$ to 4.2 V			10	
I_Q	Quiescent current consumption	$V_I = 3\text{ V}$ to 4.2 V @ $25\text{ }^\circ\text{C}$		0.4	0.8	mA
		$V_I = 5.5\text{ V}$ @ $25\text{ }^\circ\text{C}$		0.8	1.2	
$R_{DSON-SW}$	Boost switch $R_{DSON}^{(1)}$	$V_I = 4.2\text{ V}$, $I_{SW} = 100\text{ mA}$		0.4		Ω
	BVDS Breakdown voltage		40			V
$R_{DSON-LDS}$	$R_{DSON}^{(1)}$	$V_O = 25\text{ V}$, $I_O = 30\text{ mA}$		2		Ω
	BVDS Breakdown voltage		40			V
$I_{LIM-ADJ}$	Peak inductor limit range ⁽¹⁾	$R_{SET} = 10\text{ k}\Omega$ to $100\text{ k}\Omega$	0.2		1.1	A
$I_{LIM-MAX}$	Maximum peak inductor current ⁽¹⁾	$V_I = 3\text{ V}$ to 5.5 V , $R_{SET} = V_I$	0.75		1.2	A
FB	Feedback voltage	5% @ $25\text{ }^\circ\text{C}$	1.18	1.24	1.30	V
T_{ON_MAX}	Maximum ON time	$V_I = 4.2\text{ V}$		5.5		μs
T_{OFF_MIN}	Minimum OFF time	$V_I = 4.2\text{ V}$		300		ns
Eff	Efficiency, $V_I = 3.6\text{ V}$ ⁽¹⁾	$I_O = 1\text{ mA}$ to 5 mA	65			%
		$I_O = 5\text{ mA}$ to 40 mA	70			
	Efficiency, $V_I = 4.2\text{ V}$ ⁽¹⁾	$I_O = 1\text{ mA}$ to 5 mA	65			
		$I_O = 5\text{ mA}$ to 40 mA	70			
Ripple	Output ripple and noise	$V_I = 3.6\text{ V}$, $I_O = 5\text{ mA}$, $V_O = 24\text{ V}$		1.3		%
		$V_I = 3.6\text{ V}$, $I_O = 30\text{ mA}$, $V_O = 24\text{ V}$		1.3		
		$V_I = 4.2\text{ V}$, $I_O = 5\text{ mA}$, $V_O = 24\text{ V}$		1.3		
		$V_I = 4.2\text{ V}$, $I_O = 30\text{ mA}$, $V_O = 24\text{ V}$		1.3		
OV_{HYST}	Over-voltage hysteresis			2		V

Table 5. Electrical characteristics (continued)

Symbol	Parameter	Test condition	Min.	Typ.	Max.	Unit
V_{EN}	Enable input logic low	Disable Low V_{IL}			0.3	V
	Enable input logic high	Enable High V_{IH}	1.2			
Line_ V_{FB}	Line regulation V_{FB}	$V_I = 3\text{ V to }5.5\text{ V}, I_O = 5\text{ mA}$		5	35	mV
Load_ V_{FB}	Line regulation V_{FB}	$V_I = 3\text{ V to }5.5\text{ V}, I_O = 5\text{ mA}$		5	35	mV

1. Guaranteed by design.

5 Functional description

5.1 Boost controller

STOD2540 is a boost converter operating in PFM (pulsed frequency modulation) mode. The converter monitors the output voltage through the bridge resistor divider R_1 and R_2 and when the feedback voltage falls below the reference voltage, REF2, the boost switch t_{SW} turns ON and the current ramps up. The inductor current is measured by detect the temperature compensated drain voltage of the boost MOSFET. The boost turns off when its drain voltage reaches the reference REF1, the main switch remains off until the minimum off time (300 ns typical) has passed and the feedback voltage is below the reference again. A maximum ON time of 4 μ s prevent the switch t_{SW} to stay ON during a too long period of time.

In order to well calculate the bridge resistors values with a fixed V_O , the following formula can be used:

$$(V_O / 1.24) - 1 = R_1 / R_2$$

5.2 Adjustable peak inductor current limit

The peak inductor current is monitored by sensing the drain voltage of the switch t_{SW} .

Since it exceeds the temperature compensated and supply voltage compensated reference REF1, the RS flip flop is reset and t_{SW} is turned OFF.

By connecting a resistance between the pin R_{SET} and GND, the peak current limit can be adjusted from 200 mA to 1.1 A (R_{SET} from 10 k Ω to 100 k Ω). When the pin R_{SET} is directly connected to V_I , the default value is 1 A.

5.3 Enable

The ENABLE pin is a high logic input signal and allows turning on/off the controller without cutting the input voltage from the boost regulator circuit. With a high input voltage ($1.2 \text{ V} < V_{EN} < V_I + 0.3 \text{ V}$) on this pin, the device is allowed to work normally. No pull-up or pull down is present on this pin.

5.4 OVP

If the regulation loop is cut, there is no signal at the feedback pin, the PFM controller will then continue to switch without control and generate an output voltage at the SW, V_{CAP} and V_O pin exceeding the breakdown value V_{BSW} , V_{BCAP} and V_{BO} .

The over voltage protection (OVP) senses the voltage at the V_{CAP} pin. When the voltage exceed the breakdown voltage of the device the controller is automatically turned off.

A hysteresis control enables the device to automatically restart when the output voltage drops below a 2 V typical value.

5.5 Load isolation switch

When the device is in shutdown mode, a DC current path always exists between the power source and the load; increasing the standby consumption. A high side switch LDS isolates the load from the source when the STOD2540 is disabled.

5.6 Efficiency

The total consumption of some PMOLED display, can be as low as 1 mA. In order to increase the battery run time of the device, STOD2540 offers a high efficiency over a wide range of load and input voltage range.

5.7 Under voltage lockout (UVLO)

The minimum supply voltage is 3.0 V, under this value the under voltage lockout circuit operates with typical threshold 2.8 V.

When supply voltage is below 3.0 V, possible noise in the supply line could disturb the UVLO circuit causing loss of output regulation. This behavior is eliminated choosing $C_1 = 10 \mu\text{F}$ or higher.

6 Typical application

Figure 3. Basic connection

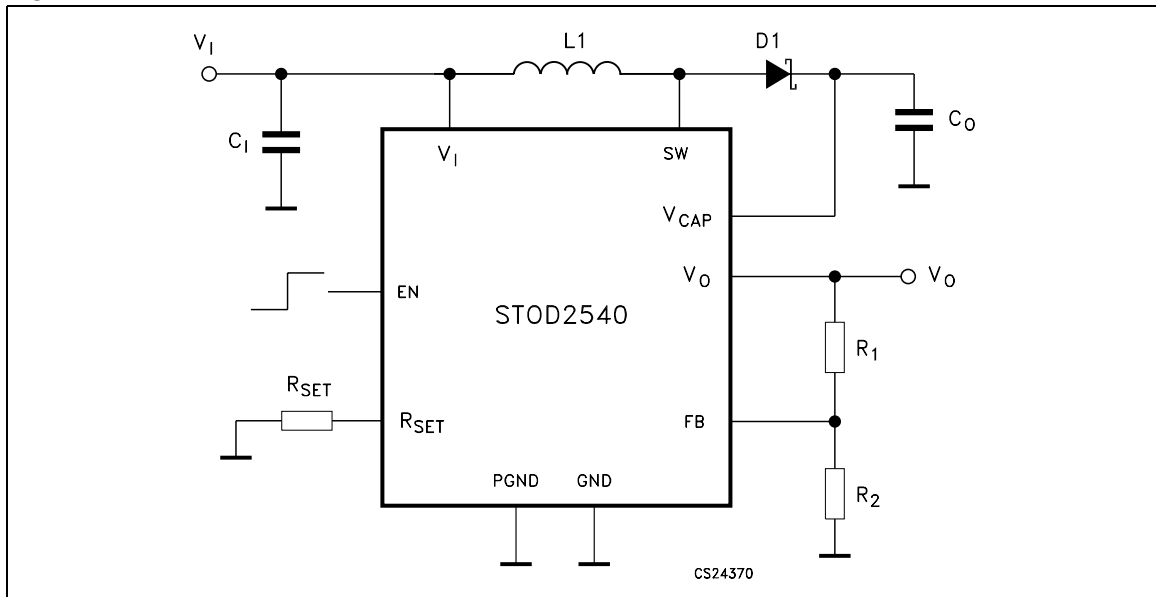

Table 6. External components (see [Figure 3](#))

Symbol	Parameter	Test	Min.	Typ.	Max.	Unit
D	Boost schottky diode	VRRM	30			V
		V_F at $I_F = 300 \text{ mA}$, $T_J = 25 \text{ }^\circ\text{C}$			0.5	V
		I_R at $V_R = 10 \text{ V}$, $T_J = 25 \text{ }^\circ\text{C}$			30	μA
R_1	Feedback resistor			180		k Ω
R_2	Feedback resistor			10		
R_{SET}	Peak current limit adjust	$I_{PK} = 200 \text{ mA to } 1.1 \text{ A}$	10		100	
C_1	Input ceramic type low ESR	Ceramic type		4.7		μF
C_0	Output capacitance: ceramic low ESR	Capacitance	4.7			μF
		Voltage	42			V
		ESR			1.6	W
L	Boost inductor (height < 2mm)	Inductance			4.7	μH
		I_{SAT} , R_{SET} pin to V_1			1	A

Note: The external components suggested in this document should be considered as a design reference guide. The performances mentioned in the electrical characteristics table are not guaranteed for all the possible electrical parameters of the components included in this list. On other hand, the operation of STOD2540 is not limited to the use of components included in this list.

6.1 Demonstration board

Figure 4. Suggested demonstration board schematic (top layer view)

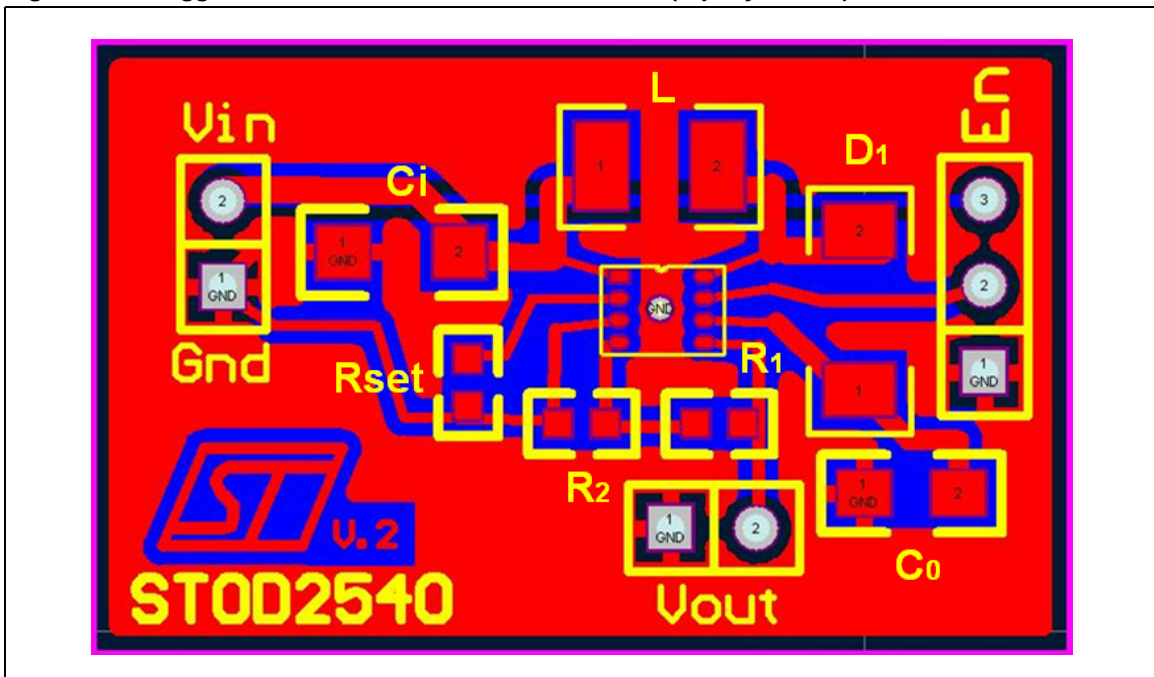

7 Typical performance characteristics

$T_J = 40\text{ }^\circ\text{C}$ to $85\text{ }^\circ\text{C}$, $V_I = 3.6\text{ V}$, $V_{EN} = 3\text{ V}$, $C_I = C_O = 4.7\text{ }\mu\text{F}$, $L = 4.7\text{ }\mu\text{H}$, $R_1 = 180\text{ k}\Omega$, $R_2 = 10\text{ k}\Omega$, $V_O = 24\text{ V}$, Typ. values @ $25\text{ }^\circ\text{C}$, unless otherwise specified.

Figure 5. Efficiency vs. output current

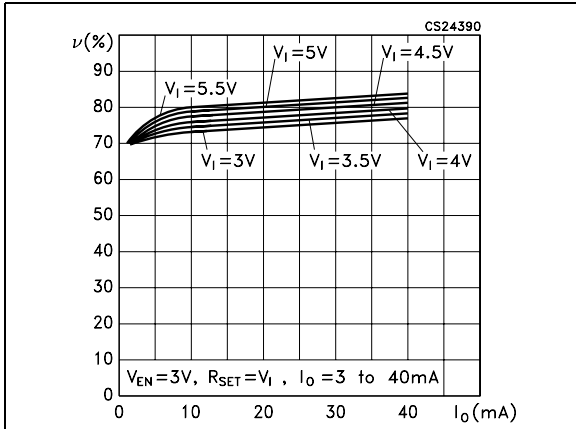

Figure 6. Efficiency vs. input voltage

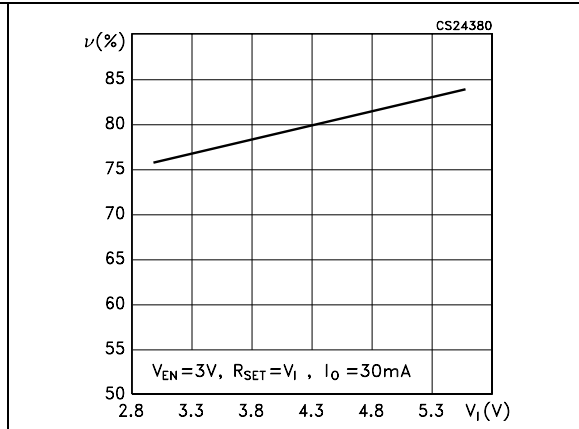

Figure 7. V_{EN} vs. temperature

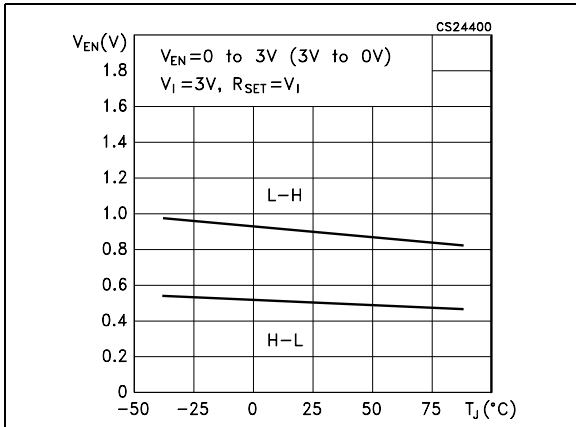

Figure 8. V_{FB} vs. input voltage

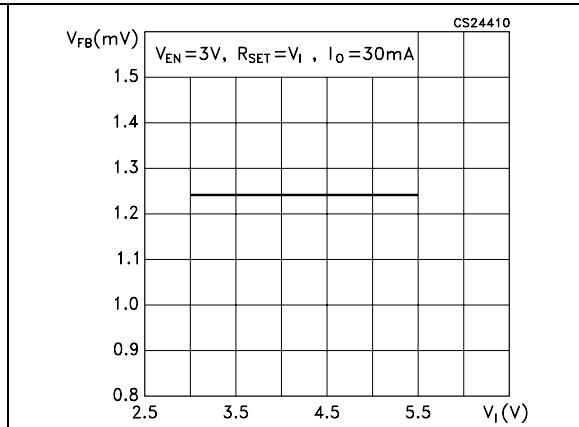

Figure 9. V_{FB} vs. output current

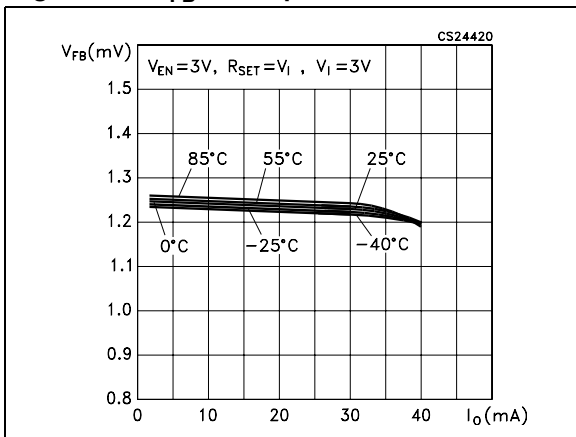

Figure 10. V_{FB} vs. output current

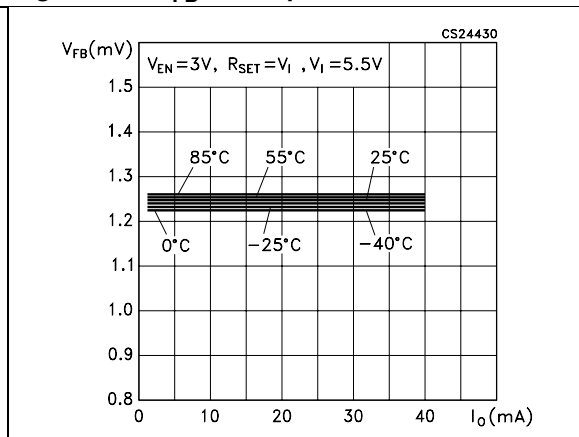

Figure 11. V_{OVP} vs. temperature

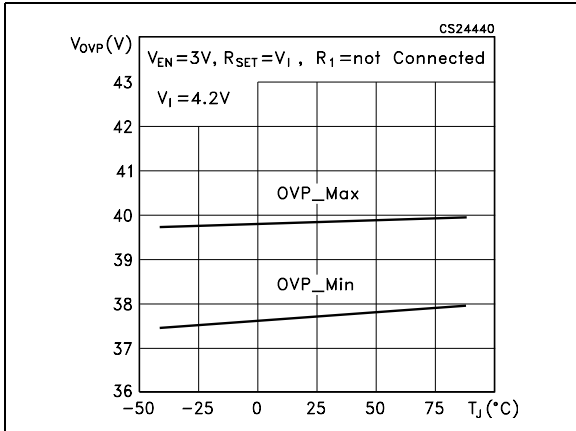

Figure 12. V_{RIPPLE} vs. input voltage

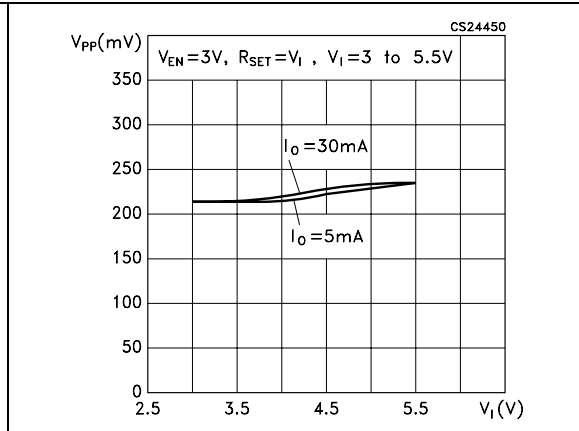

Figure 13. I_{LIM_MAX} vs. input voltage

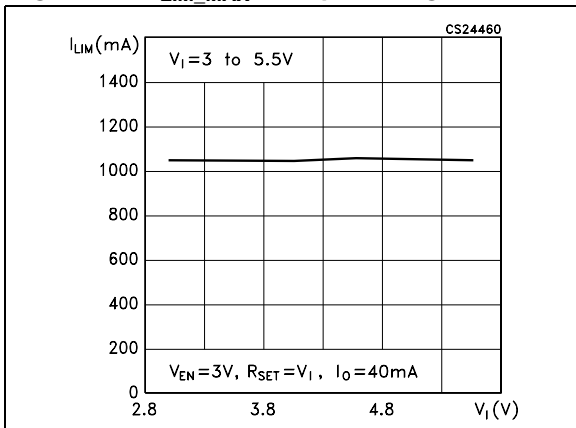

Figure 14. I_{LIM_MAX} vs. temperature

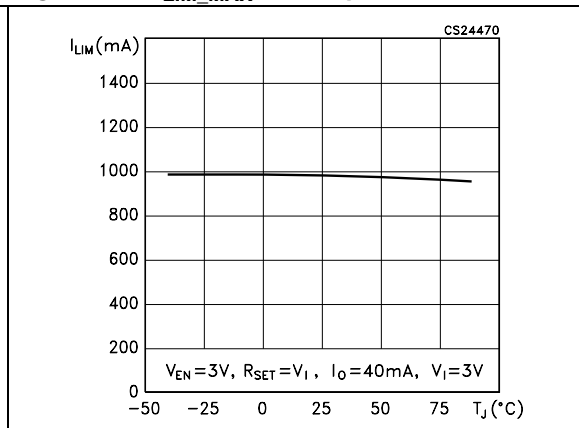

Figure 15. I_{LIM_MAX} vs. R_{SET}

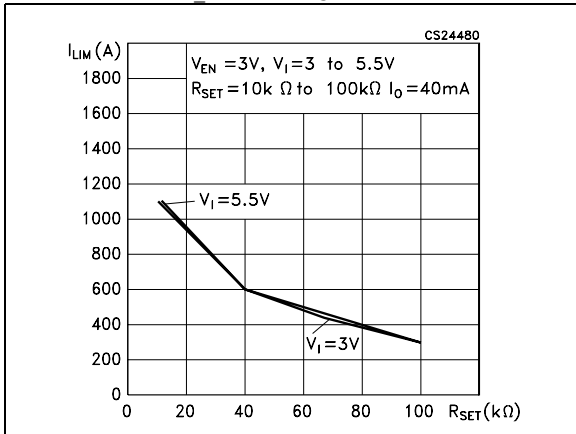

Figure 16. I_Q vs. temperature

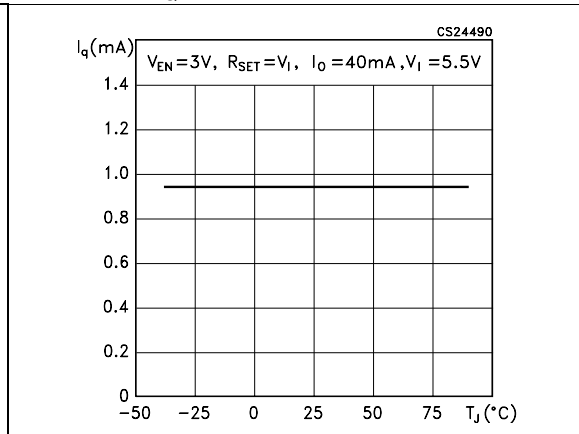

Figure 17. t_{ON_MAX} vs. temperature

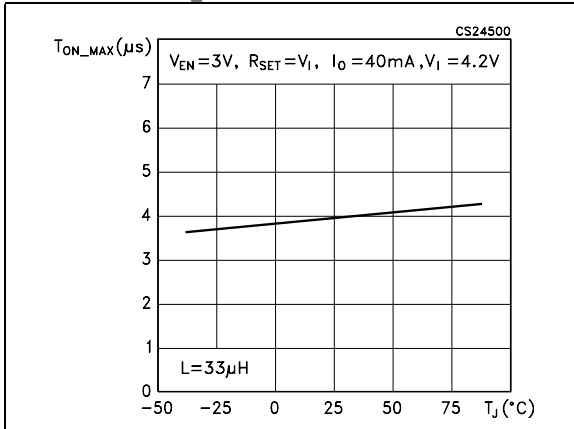

Figure 18. t_{OFF_MIN} vs. temperature

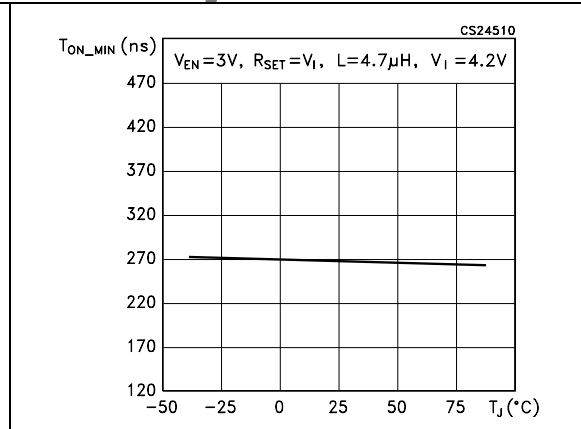

Figure 19. Line V_{FB} vs. temperature

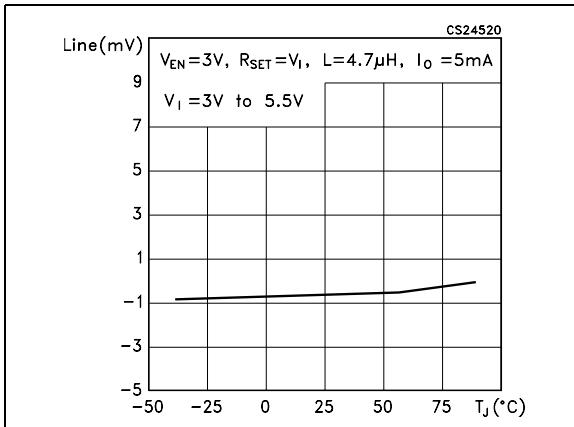
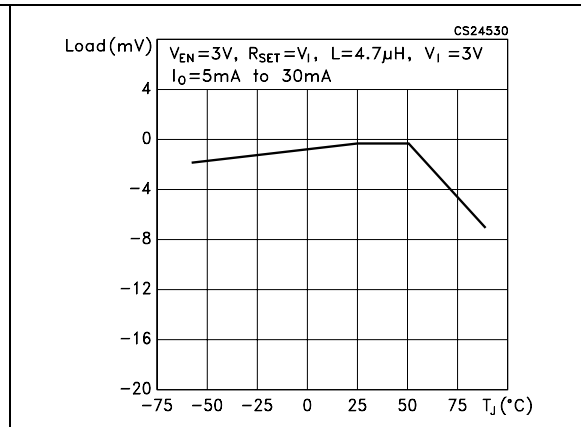

Figure 20. Load V_{FB} vs. temperature



8 Package mechanical data

In order to meet environmental requirements, ST offers these devices in different grades of ECOPACK[®] packages, depending on their level of environmental compliance. ECOPACK[®] specifications, grade definitions and product status are available at: www.st.com. ECOPACK[®] is an ST trademark.

Table 7. QFN8 (3 x 3 mm) mechanical data

Dim.	mm.		
	Min.	Typ.	Max.
A	0.80	0.90	1.00
A1	0	0.02	0.05
A3		0.20	
b	0.25	0.30	0.35
D	2.85	3.00	3.15
D2	2.49	2.64	2.74
E	2.85	3.00	3.15
E2	1.75	1.90	2.00
e		0.65	
L	0.30	0.40	0.50

Figure 21. Drawing dimension QFN8 (3 x 3 mm)

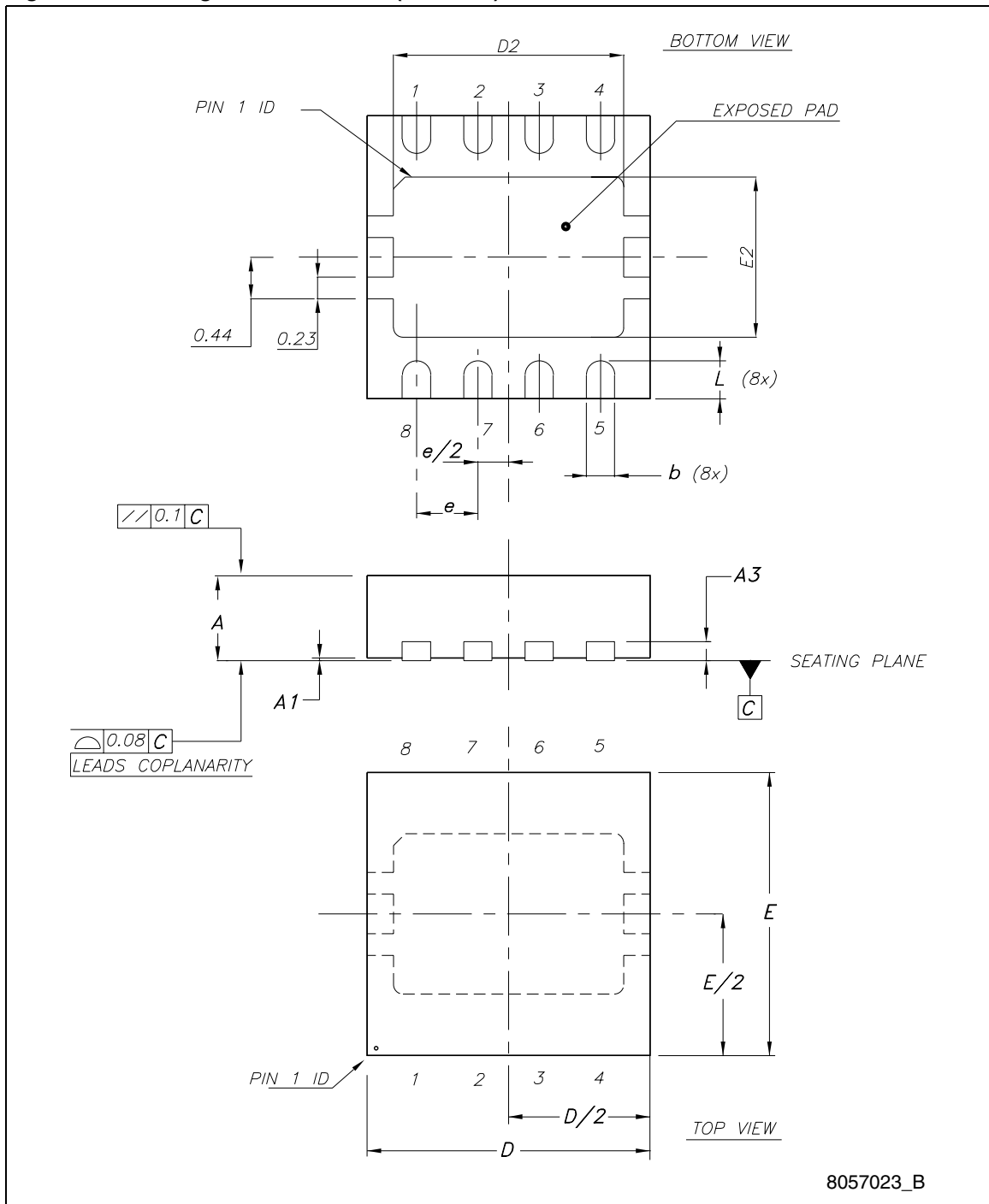

Tape & reel QFNxx/DFNxx (3x3) mechanical data

Dim.	mm.			inch.		
	Min.	Typ.	Max.	Min.	Typ.	Max.
A			180			7.087
C	12.8		13.2	0.504		0.519
D	20.2			0.795		
N	60			2.362		
T			14.4			0.567
Ao		3.3		0.130		
Bo		3.3		0.130		
Ko		1.1		0.043		
Po		4		0.157		
P		8		0.315		

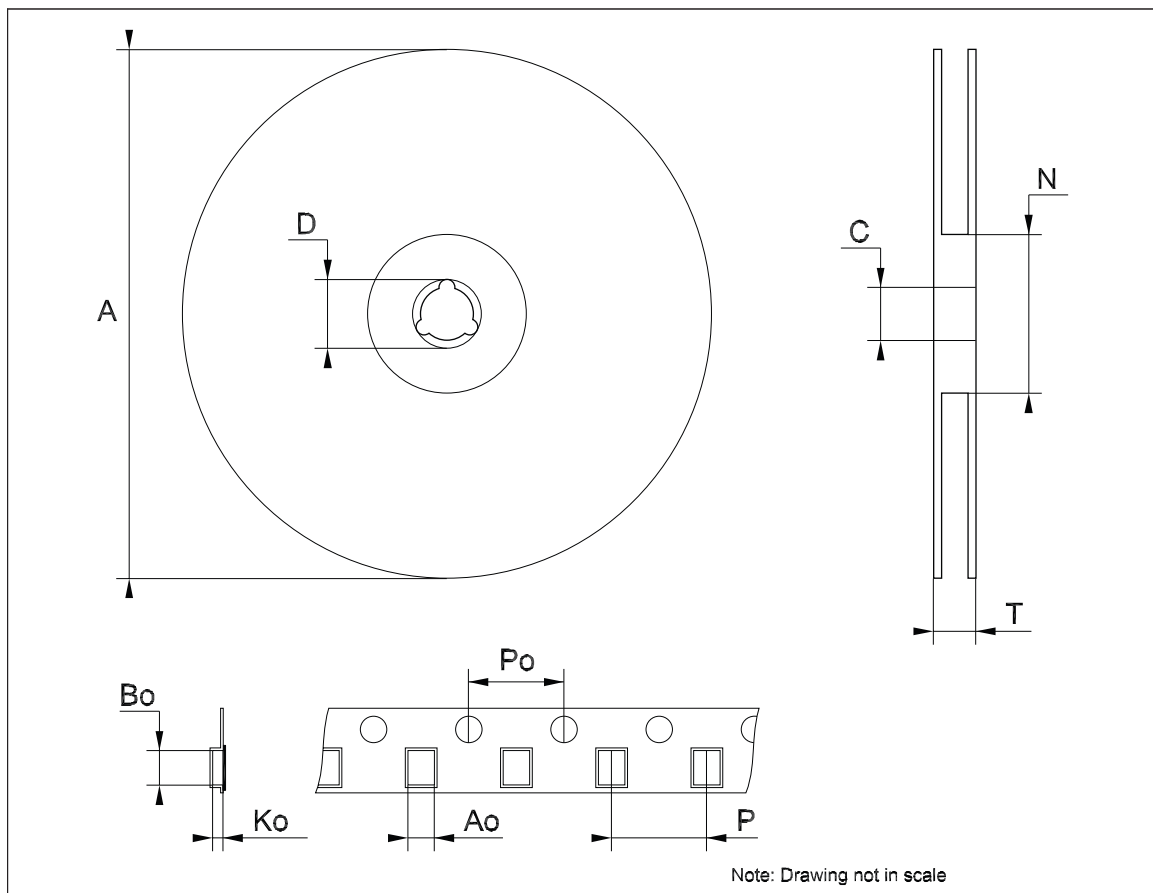
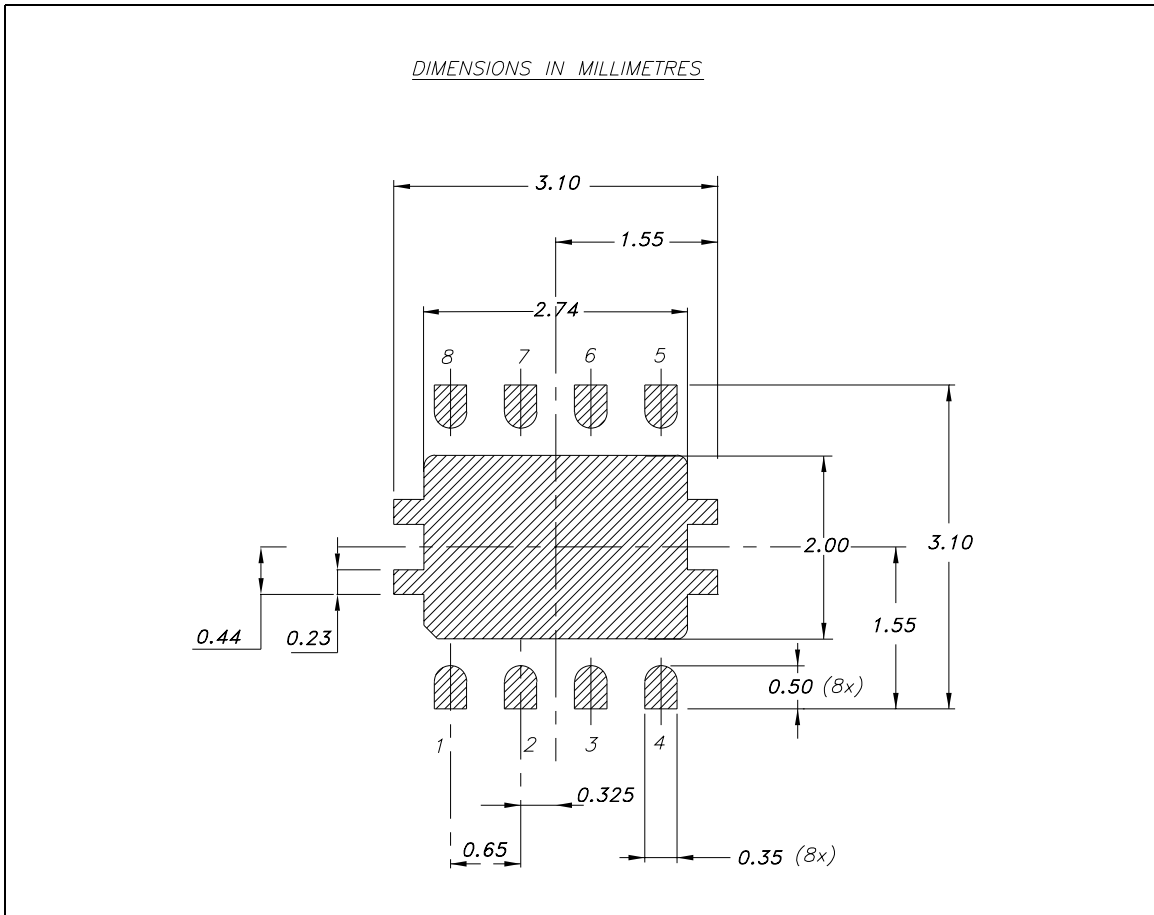

Figure 22. QFN8 (3x3) footprint recommended data



9 Revision history

Table 8. Document revision history

Date	Revision	Changes
22-Mar-2006	1	Initial release.
03-Apr-2006	2	Add fig. 2 demonstration board on page 3.
08-Jun-2006	3	Description in cover page updated.
23-Jun-2006	4	Change range of R _{SET} value and add description paragraph 5.7.
11-Sep-2006	5	Mistake on table 4 Ripple test value 3.6 V ==> 4.2 V.
27-Feb-2009	6	Modified mechanical data.
03-Mar-2009	7	Modified packaging Table 1 on page 1 .
11-Mar-2009	8	Modified Figure 2 on page 4 and added Figure 22 on page 18 .
25-Nov-2009	9	Modified Table 1 on page 1 .
01-Jul-2010	10	Modified: Table 7 on page 15 , Figure 21 on page 16 and Figure 22 on page 18 .

Please Read Carefully:

Information in this document is provided solely in connection with ST products. STMicroelectronics NV and its subsidiaries ("ST") reserve the right to make changes, corrections, modifications or improvements, to this document, and the products and services described herein at any time, without notice.

All ST products are sold pursuant to ST's terms and conditions of sale.

Purchasers are solely responsible for the choice, selection and use of the ST products and services described herein, and ST assumes no liability whatsoever relating to the choice, selection or use of the ST products and services described herein.

No license, express or implied, by estoppel or otherwise, to any intellectual property rights is granted under this document. If any part of this document refers to any third party products or services it shall not be deemed a license grant by ST for the use of such third party products or services, or any intellectual property contained therein or considered as a warranty covering the use in any manner whatsoever of such third party products or services or any intellectual property contained therein.

UNLESS OTHERWISE SET FORTH IN ST'S TERMS AND CONDITIONS OF SALE ST DISCLAIMS ANY EXPRESS OR IMPLIED WARRANTY WITH RESPECT TO THE USE AND/OR SALE OF ST PRODUCTS INCLUDING WITHOUT LIMITATION IMPLIED WARRANTIES OF MERCHANTABILITY, FITNESS FOR A PARTICULAR PURPOSE (AND THEIR EQUIVALENTS UNDER THE LAWS OF ANY JURISDICTION), OR INFRINGEMENT OF ANY PATENT, COPYRIGHT OR OTHER INTELLECTUAL PROPERTY RIGHT.

UNLESS EXPRESSLY APPROVED IN WRITING BY AN AUTHORIZED ST REPRESENTATIVE, ST PRODUCTS ARE NOT RECOMMENDED, AUTHORIZED OR WARRANTED FOR USE IN MILITARY, AIR CRAFT, SPACE, LIFE SAVING, OR LIFE SUSTAINING APPLICATIONS, NOR IN PRODUCTS OR SYSTEMS WHERE FAILURE OR MALFUNCTION MAY RESULT IN PERSONAL INJURY, DEATH, OR SEVERE PROPERTY OR ENVIRONMENTAL DAMAGE. ST PRODUCTS WHICH ARE NOT SPECIFIED AS "AUTOMOTIVE GRADE" MAY ONLY BE USED IN AUTOMOTIVE APPLICATIONS AT USER'S OWN RISK.

Resale of ST products with provisions different from the statements and/or technical features set forth in this document shall immediately void any warranty granted by ST for the ST product or service described herein and shall not create or extend in any manner whatsoever, any liability of ST.

ST and the ST logo are trademarks or registered trademarks of ST in various countries.

Information in this document supersedes and replaces all information previously supplied.

The ST logo is a registered trademark of STMicroelectronics. All other names are the property of their respective owners.

© 2010 STMicroelectronics - All rights reserved

STMicroelectronics group of companies

Australia - Belgium - Brazil - Canada - China - Czech Republic - Finland - France - Germany - Hong Kong - India - Israel - Italy - Japan - Malaysia - Malta - Morocco - Philippines - Singapore - Spain - Sweden - Switzerland - United Kingdom - United States of America

www.st.com