

T18U Series Opposed Mode Ultrasonic Sensors

Sensor pairs with dual sensing ranges; 12 to 30V dc operation



- Dual range/dual resolution opposed ultrasonic mode sensors; ideal for reliable sensing of clear objects or materials
- Rugged design for use in demanding environments: rated NEMA 6P (IEC IP 67), wide operating temperature range of -40° to +70°C
- Alignment indicator flashes at a rate proportional to the received signal strength
- Highly immune to ambient sonic and electrical noise
- Popular, patented* T-style right-angle sensor package with 18 mm threaded mounting hub; cabled or quick disconnect models
- 12 to 30V dc operation; choose receivers with either NPN (sinking) or PNP (sourcing) output; outputs are short-circuit protected



* U. S. Design Patent No. D361057

Description

EZ-BEAM T18U Series sensors are opposed mode ultrasonic emitter/receiver pairs. They utilize an advanced built-in microprocessor to analyze the received sonic signal and control an indicator LED located on the back of the receiver. The receiver LED flashes at a rate proportional to received sonic signal strength. This indicator greatly simplifies sensor alignment, and alerts personnel to marginal sensing conditions due to gradual misalignment or environmental factors. The receiver is precisely tuned to the ultrasonic emitter, making this sensor pair highly-immune to both sonic and electrical ambient noise.

T18U receivers may be wired for either of two resolution modes: NORMAL or HIGH. The modes are selected by the polarity of the supply voltage (see hookup diagrams). The NORMAL resolution mode offers a sensing range of 24 inches (60 cm). The NORMAL mode maximizes sensing energy, as is required in demanding environments. The HIGH resolution mode yields a sensing range of up to 12 inches (30 cm). The HIGH resolution mode maximizes sensing response, as is needed in high-speed counting applications.

Opposed mode ultrasonics are very useful for highly-reliable sensing of clear materials, which is always a challenge for photoelectric modes. T18U Series ultrasonic sensors are designed for demanding sensing environments. Housings are tough, NEMA 6P-rated VALOX®. Electronics are epoxy encapsulated. The acoustic face

of both emitter and receiver are epoxy-reinforced for extreme durability and moisture resistance.

T18U emitters include a green LED indicator for power “on”. The receivers include two multi-function LEDs. The green receiver LED indicates power “on”, and also indicates an output overload when it flashes. The yellow (amber) LED indicates received signal. As mentioned, the yellow LED pulses from full to half intensity at a rate which parallels received signal strength.

T18Us are powered by 12 to 30V dc. Receivers are available with either NPN current sinking or PNP current sourcing outputs. All receivers offer two outputs: one normally open and one normally closed. The normally open output conducts when the receiver hears its emitter. The normally closed output is active when the sonic beam is blocked. Both outputs are rated at 150 mA, and both may be used simultaneously.

T18U EZ-BEAM ultrasonic sensors are available with either an attached 6 1/2 foot long PVC-covered cable, or with a 4-pin euro-type quick disconnect fitting. Thirty-foot cables are available by request. Mating quick-disconnect cables are also available (refer to page 3).

T18U Series Sensor Models

Sensor Model	Part No.	Function	Output Type	Termination
T186UE	38269	Emitter		6-1/2 foot (2 m) long
T18VN6UR	38512	Receiver	NPN sinking	PVC-jacketed
T18VP6UR	38510	Receiver	PNP sourcing	attached cable
T186UE w/30	40096	Emitter		30 foot (10 m) long
T18VN6UR w/30	40095	Receiver	NPN sinking	PVC-jacketed
T18VP6UR w/30	40094	Receiver	PNP sourcing	attached cable
T186UEQ	38509	Emitter		Euro-style quick-
T18VN6URQ	38513	Receiver	NPN sinking	disconnect fitting;
T18VP6URQ	38511	Receiver	PNP sourcing	use QD cable (p. 3).

T18U Series

Specifications

Sensing range: (no minimum range)
NORMAL resolution mode: to 24 inches (60 cm)
HIGH resolution mode: to 12 inches (30 cm)

Sensing beam: ultrasonic, 230 KHz.

Minimum spacing (adjacent pairs):
5 cm for emitter-to-receiver separations of up to 15 cm.
Add 1 cm of adjacent-pair spacing for every 10 cm of emitter-to-receiver spacing beyond 15 cm.

Supply voltage: 12 to 30V dc, 10% maximum ac ripple.

Supply current: 50 mA (emitters); 35 mA (receivers), exclusive of output load.

Receiver output configuration:
T18VN models: NPN sinking, N.O. and N.C. (complementary)
T18VP models: PNP sourcing, N.O. and N.C. (complementary)

Receiver output rating: 150 mA maximum each output at 25°C, derated to 100 mA at 70°C (derate ≈ 1 mA per °C).

Both outputs may be used simultaneously.

On-state saturation voltage: <1.5 V at 10 mA; <2.0 V at 150 mA

Off-state leakage current: < 1 microamp at 30V dc

Output protection: Overload and short-circuit protected.

No false pulse upon receiver power-up: false pulse protection causes a 100 millisecond delay upon power-up.

Response time:

NORMAL resolution mode: 2 milliseconds “on” and “off”

HIGH resolution mode: 1 millisecond “on” and “off”

Rep rate:

NORMAL resolution mode: 125 Hz maximum

HIGH resolution mode: 200 Hz maximum.

Mechanical sensing repeatability at 12 inch (30 cm) range:

NORMAL resolution mode: <0.08 inch (<2 mm)

HIGH resolution mode: <0.04 inch (<1 mm)

Sensing resolution: (See Tables, page 4)

Beam angle (-3dB full angle): $15 \pm 2^\circ$

Indicators: Emitters have a green LED for dc power “on”. Receivers have two LEDs, one yellow and one green. Indications are as follows:

Green glowing steadily = dc power “on”

Green flashing = output overloaded

Yellow flashing = sonic signal received (flash rate is proportional to received signal strength; flash is from full to half intensity).

Construction: Patented* T-style yellow VALOX® housing with black VALOX® back cover. Transducer housing is threaded M18 x 1.

Mating jam nut is supplied for mounting. Acoustic face is epoxy reinforced.

Circuitry is epoxy-encapsulated. Rated NEMA 6P, IEC IP67.

NOTE: VALOX® is a registered trademark of General Electric Co.

Cabling options:

Emitters: 6 1/2 foot long (2 m) attached PVC-covered 2-wire cable or 4-pin euro-style quick disconnect fitting.

Receivers: 6 1/2 foot long (2 m) attached PVC-covered 4-wire cable or 4-pin euro-style quick disconnect fitting.

30-foot long cables are available by request.

Mating euro-style quick disconnect cables are also available (page 3)

Dimensions

Cabled models shown below. QD connector adds 0.6 inches (15,0 mm) in overall height to quick-disconnect models (see also drawings on page 3).

Front

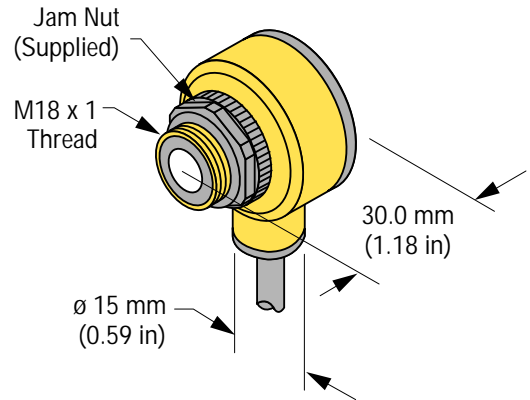

Rear

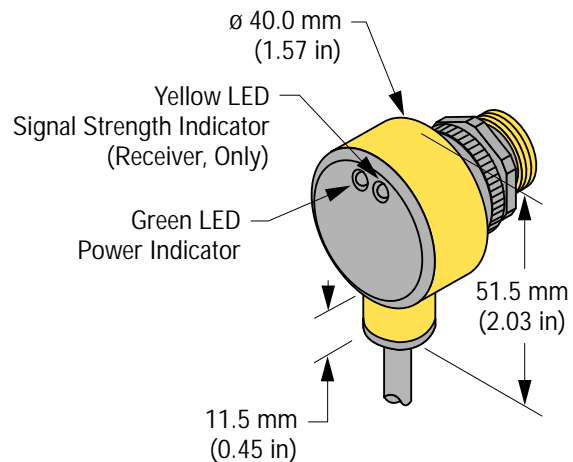

Vibration and mechanical shock:

Meets Mil. Std 202F requirements.

Method 201A (Vibration: frequency 10 to 60 Hz, max., double amplitude 0.06-inch, maximum acceleration 10G).

Method 213B conditions H & I (Shock: 75G with unit operation: 100G for non-operation)

Also meets IEC 947-5-2 requirements: 30G, 11 ms duration, half sine wave.

Operating temperature range: -40° to +70°C (-40° to 158°F)