

## LM195/LM395 Ultra Reliable Power Transistors

### General Description

The LM195/LM395 are fast, monolithic power integrated circuits with complete overload protection. These devices, which act as high gain power transistors, have included on the chip, current limiting, power limiting, and thermal overload protection making them virtually impossible to destroy from any type of overload. In the standard TO-3 transistor power package, the LM195 will deliver load currents in excess of 1.0A and can switch 40V in 500 ns.

The inclusion of thermal limiting, a feature not easily available in discrete designs, provides virtually absolute protection against overload. Excessive power dissipation or inadequate heat sinking causes the thermal limiting circuitry to turn off the device preventing excessive heating.

The LM195 offers a significant increase in reliability as well as simplifying power circuitry. In some applications, where protection is unusually difficult, such as switching regulators, lamp or solenoid drivers where normal power dissipation is low, the LM195 is especially advantageous.

The LM195 is easy to use and only a few precautions need be observed. Excessive collector to emitter voltage can destroy the LM195 as with any power transistor. When the device is used as an emitter follower with low source imped-

ance, it is necessary to insert a 5.0k resistor in series with the base lead to prevent possible emitter follower oscillations. Although the device is usually stable as an emitter follower, the resistor eliminates the possibility of trouble without degrading performance. Finally, since it has good high frequency response, supply bypassing is recommended.

For low-power applications (under 100 mA), refer to the LP395 Ultra Reliable Power Transistor.

The LM195/LM395 are available in the standard TO-3, Kovar TO-5, and TO-220 packages. The LM195 is rated for operation from  $-55^{\circ}\text{C}$  to  $+150^{\circ}\text{C}$  and the LM395 from  $0^{\circ}\text{C}$  to  $+125^{\circ}\text{C}$ .

### Features

- Internal thermal limiting
- Greater than 1.0A output current
- 3.0  $\mu\text{A}$  typical base current
- 500 ns switching time
- 2.0V saturation
- Base can be driven up to 40V without damage
- Directly interfaces with CMOS or TTL
- 100% electrical burn-in

### Simplified Circuit

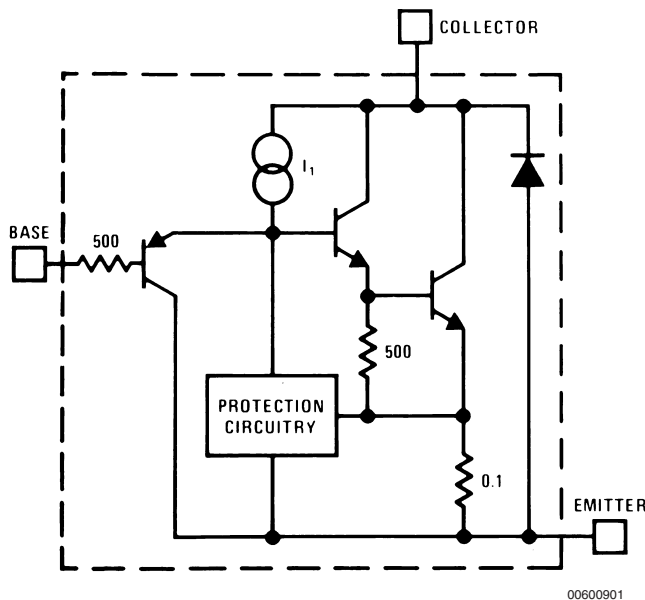

### 1.0 Amp Lamp Flasher

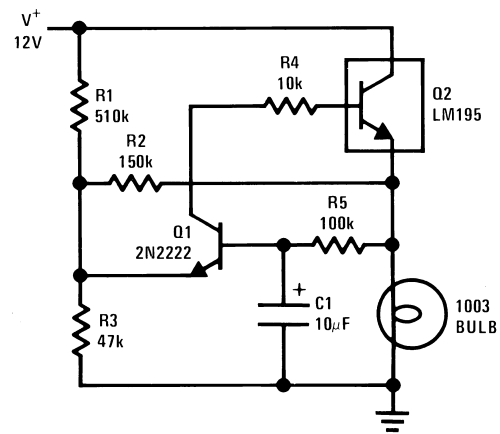

## Absolute Maximum Ratings (Note 1)

If Military/Aerospace specified devices are required, please contact the National Semiconductor Sales Office/Distributors for availability and specifications.

Collector to Emitter Voltage	
LM195	42V
LM395	36V
Collector to Base Voltage	
LM195	42V
LM395	36V
Base to Emitter Voltage (Forward)	
LM195	42V
LM395	36V

Base to Emitter Voltage (Reverse)	20V
Collector Current	Internally Limited
Power Dissipation	Internally Limited
Operating Temperature Range	
LM195	-55°C to +150°C
LM395	0°C to +125°C
Storage Temperature Range	-65°C to +150°C
Lead Temperature	
(Soldering, 10 sec.)	260°C

## Preconditioning

100% Burn-In In Thermal Limit

## Electrical Characteristics

(Note 2)

Parameter	Conditions	LM195			LM395			Units
		Min	Typ	Max	Min	Typ	Max	
Collector-Emitter Operating Voltage (Note 4)	$I_Q \leq I_C \leq I_{MAX}$			42			36	V
Base to Emitter Breakdown Voltage	$0 \leq V_{CE} \leq V_{CEMAX}$	42			36	60		V
Collector Current								
TO-3, TO-220	$V_{CE} \leq 15V$	1.2	2.2		1.0	2.2		A
TO-5	$V_{CE} \leq 7.0V$	1.2	1.8		1.0	1.8		A
Saturation Voltage	$I_C \leq 1.0A, T_A = 25^\circ C$		1.8	2.0		1.8	2.2	V
Base Current	$0 \leq I_C \leq I_{MAX}$ $0 \leq V_{CE} \leq V_{CEMAX}$		3.0	5.0		3.0	10	$\mu A$
Quiescent Current ( $I_Q$ )	$V_{be} = 0$ $0 \leq V_{CE} \leq V_{CEMAX}$		2.0	5.0		2.0	10	mA
Base to Emitter Voltage	$I_C = 1.0A, T_A = +25^\circ C$		0.9			0.9		V
Switching Time	$V_{CE} = 36V, R_L = 36\Omega,$ $T_A = 25^\circ C$		500			500		ns
Thermal Resistance Junction to Case (Note 3)	TO-3 Package (K)		2.3	3.0		2.3	3.0	$^\circ C/W$
	TO-5 Package (H)		12	15		12	15	$^\circ C/W$
	TO-220 Package (T)					4	6	$^\circ C/W$

**Note 1:** "Absolute Maximum Ratings" indicate limits beyond which damage to the device may occur. Operating Ratings indicate conditions for which the device is functional, but do not guarantee specific performance limits.

**Note 2:** Unless otherwise specified, these specifications apply for  $-55^\circ C \leq T_J \leq +150^\circ C$  for the LM195 and  $0^\circ C \leq +125^\circ C$  for the LM395.

**Note 3:** Without a heat sink, the thermal resistance of the TO-5 package is about  $+150^\circ C/W$ , while that of the TO-3 package is  $+35^\circ C/W$ .

**Note 4:** Selected devices with higher breakdown available.

**Note 5:** Refer to RETS195H and RETS195K drawings of military LM195H and LM195K versions for specifications.

**Physical Dimensions** inches (millimeters) unless otherwise noted (Continued)

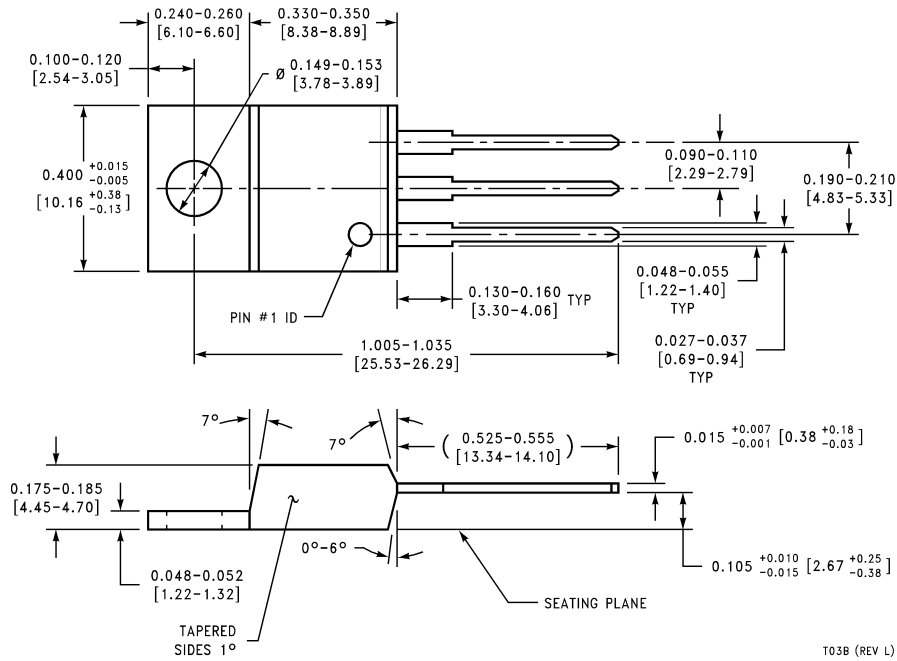

**TO-220 Plastic Package  
Order Number LM395T  
NS Package Number T03B**