

Panasonic
ideas for life

High sensitivity and low on-resistance.
DIP (1 Form A) 6-pin type.

HE PhotoMOS
(AQV25○)

FEATURES

- Highly sensitive and low on-resistance**
- Controls various types of loads such as relays, motors, lamps and solenoids.**
- Optical coupling for extremely high isolation**
5,000 Vrms I/O isolation available.
- Low-level off state leakage current**
- Eliminates the need for a power supply to drive the power MOSFET**
A power supply used to drive the power MOSFET is unnecessary because of the built-in optoelectronic device. This results in easy circuit design and small PC board area.
- Low thermal electromotive force (Approx. 1 μV)**

TYPICAL APPLICATIONS

- High-speed inspection machines
- Telephone equipment
- Data communication equipment

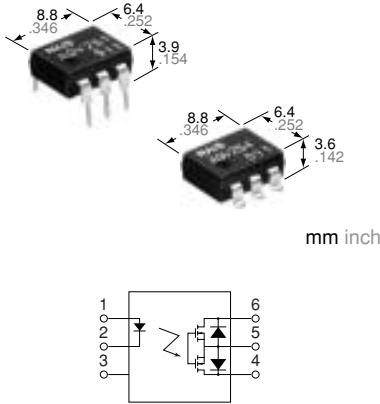

TYPES

1. I/O isolation voltage: 1,500 V AC

Output rating*		Part No.				Packing quantity	
		Through hole terminal	Surface-mount terminal		Tube		
Load voltage	Load current	Tube packing style		Tape and reel packing style		1 tube contains 50 pcs. 1 batch contains 500 pcs.	1,000 pcs.
				Picked from the 1/2/3-pin side	Picked from the 4/5/6-pin side		
40 V	500 mA	AQV251	AQV251A	AQV251AX	AQV251AZ		
60 V	400 mA	AQV252	AQV252A	AQV252AX	AQV252AZ		
100 V	350 mA	AQV255	AQV255A	AQV255AX	AQV255AZ		
200 V	250 mA	AQV257	AQV257A	AQV257AX	AQV257AZ		
250 V	200 mA	AQV253	AQV253A	AQV253AX	AQV253AZ		
400 V	150 mA	AQV254	AQV254A	AQV254AX	AQV254AZ		
1,000 V	30 mA	AQV259	AQV259A	AQV259AX	AQV259AZ		
1,500 V	20 mA	AQV258	AQV258A	AQV258AX	AQV258AZ		

2. I/O isolation voltage: Reinforced 5,000 V

Output rating*		Part No.				Packing quantity	
		Through hole terminal	Surface-mount terminal		Tube		
Load voltage	Load current	Tube packing style		Tape and reel packing style		1 tube contains 50 pcs. 1 batch contains 500 pcs.	1,000 pcs.
				Picked from the 1/2/3-pin side	Picked from the 4/5/6-pin side		
250 V	200 mA	AQV253H	AQV253HA	AQV253HAX	AQV253HAZ		
400 V	150 mA	AQV254H	AQV254HA	AQV254HAX	AQV254HAZ		

*Indicate the peak AC and DC values.

Note: For space reasons, the SMD terminal shape indicator "A" and the package type indicator "X" and "Z" are omitted from the seal.

RATING

1. Absolute maximum ratings (Ambient temperature: 25°C 77°F)

Item		Sym- bol	Type of con- nection	AQV251(A)	AQV252(A)	AQV255(A)	AQV257(A)	AQV253(A)	AQV254(A)	AQV259(A)	AQV258(A)	AQV253H(A)	AQV254H(A)	Remarks		
Input	LED forward current	I_F		50 mA												
	LED reverse voltage	V_R		5 V												
	Peak forward current	I_{FP}		1 A										f = 100 Hz, Duty factor +0.1%		
	Power dissipation	P_{in}		75 mW												
Output	Load voltage (peak AC)	V_L		40 V	60 V	100 V	200 V	250 V	400 V	1,000 V	1,500 V	250 V	400 V			
	Continuous load current	I_L	A	0.5 A	0.4 A	0.35 A	0.25 A	0.2 A	0.15 A	0.03 A	0.02 A	0.2 A	0.15 A	A connection: Peak AC, DC B, C connection: DC		
			B	0.7 A	0.6 A	0.45 A	0.35 A	0.3 A	0.18 A	0.04 A	0.025 A	0.3 A	0.18 A			
			C	1.0 A	0.8 A	0.70 A	0.5 A	0.4 A	0.25 A	0.05 A	0.04 A	0.4 A	0.25 A			
	Peak load current	I_{peak}		1.8 A	1.5 A	1.0 A	0.75 A	0.6 A	0.5 A	0.09 A	0.06 A	0.6 A	0.5 A	A connection: 100 ms (1 shot) $V_L = DC$		
Power dissipation	P_{out}		360 mW													
Total power dissipation		P_T		410 mW												
I/O isolation voltage		V_{iso}		1,500 V AC								5,000 V AC				
Temperature limits	Operating	T_{opr}		-40°C to +85°C -40°F to +185°F										Non-condensing at low temperatures		
	Storage	T_{stg}		-40°C to +100°C -40°F to +212°F												

2. Electrical characteristics (Ambient temperature: 25°C 77°F)

Item		Sym- bol	Type of con- nection	AQV251(A)	AQV252(A)	AQV255(A)	AQV257(A)	AQV253(A)	AQV254(A)	AQV259(A)	AQV258(A)	AQV253H(A)	AQV254H(A)	Condition		
Input	LED operate current	Typical	I_{Fon}	0.9 mA								1.4 mA				$I_L = Max.$
		Maximum		3 mA												
	LED turn off current	Minimum	I_{Foff}	0.4 mA												$I_L = Max.$
		Typical		0.8 mA								1.3 mA				
LED dropout voltage	Typical	V_F		1.25 V (1.14 V at $I_F = 5 mA$)												$I_F = 50 mA$
	Maximum			1.5 V												
Output	On resistance	Typical	A	0.6 Ω	0.74 Ω	1.8 Ω	2.6 Ω	5.5 Ω	12.4 Ω	85 Ω	345 Ω	5.5 Ω	12.4 Ω	$I_F = 5 mA$ $I_L = Max.$ Within 1 s on time		
		Maximum		1 Ω	1.4 Ω	2.5 Ω	4 Ω	8 Ω	16 Ω	200 Ω	500 Ω	8 Ω	16 Ω			
		Typical	B	0.3Ω	0.37 Ω	0.9 Ω	1.4 Ω	2.7 Ω	6.2 Ω	60 Ω	345 Ω	2.7 Ω	6.2 Ω	$I_F = 5 mA$ $I_L = Max.$ Within 1 s on time		
		Maximum		0.5 Ω	0.7 Ω	1.25 Ω	2 Ω	4 Ω	8 Ω	100 Ω	500 Ω	4 Ω	8 Ω			
		Typical	C	0.15 Ω	0.18 Ω	0.45 Ω	0.7 Ω	1.4 Ω	3.1 Ω	30 Ω	160 Ω	1.4 Ω	3.1 Ω	$I_F = 5 mA$ $I_L = Max.$ Within 1 s on time		
		Maximum		0.25 Ω	0.35 Ω	0.63 Ω	1 Ω	2 Ω	4 Ω	50 Ω	250 Ω	2 Ω	4 Ω			
Off state leakage current	Maximum			1 μA						10 μA		1 μA		$I_F = 0 mA$ $V_L = Max.$		
Transfer characteristics	Switching speed	Turn on time*	T_{on}	Typical	1.7 ms	1.4 ms	0.9 ms	1.5 ms	0.8ms	0.8ms	0.6ms	0.35 ms	2.4ms	1.8ms	$I_F = 5 mA$ $I_L = Max.$	
		Maximum		3 ms		2 ms	3 ms	2 ms		1 ms		4 ms	3 ms			
	Turn off time*	Typical	T_{off}	0.07 ms		0.09 ms	0.1 ms	0.06 ms	0.05 ms	0.04 ms		0.06 ms	0.05 ms	$I_F = 5 mA$ $I_L = Max.$		
		Maximum		0.2 ms												
I/O capacitance	Typical	C_{iso}		1.3 pF												f = 1 MHz $V_B = 0 V$
	Maximum			3 pF												
Initial I/O isolation resistance	Minimum	R_{iso}		1,000 MΩ										500 V DC		

Note: Recommendable LED forward current

Standard type: 5 mA

Reinforced type: 5 to 10 mA

*Turn on/Turn off time

