

RoHS EC103xx & SxSx Series

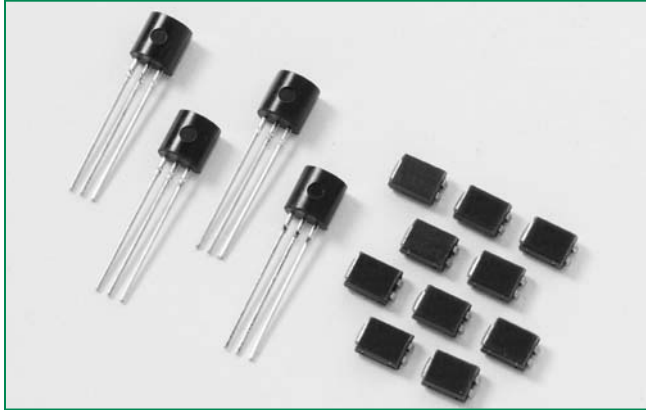

Description

Excellent unidirectional switches for phase control applications such as heating and motor speed controls. Sensitive gate SCRs are easily triggered with microAmps of current as furnished by sense coils, proximity switches, and microprocessors.

Features & Benefits

- RoHS compliant
- Glass – passivated junctions
- Voltage capability up to 600 V
- Surge capability up to 20 A

Main Features

| Symbol | Value | Unit |
|-------------------|------------|---------|
| $I_{T(RMS)}$ | 0.8 | A |
| V_{DRM}/V_{RRM} | 400 to 600 | V |
| I_{GT} | 12 to 500 | μA |

Applications

Typical applications are capacitive discharge systems for strobe lights and gas engine ignition. Also controls for power tools, home/brown goods and white goods appliances.

Schematic Symbol

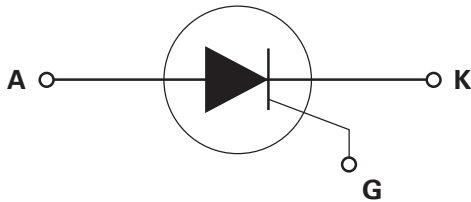

Absolute Maximum Ratings – Sensitive SCRs

| Symbol | Parameter | Test Conditions | Value | Unit |
|--------------|---|--|------------|------------|
| $I_{T(RMS)}$ | RMS on-state current | $T_c = 75^\circ C$ | 0.8 | A |
| I_{TSM} | Peak non-repetitive surge current | single half cycle; $f = 50Hz$; T_j (initial) = $25^\circ C$ | 16 | A |
| | | single half cycle; $f = 60Hz$; T_j (initial) = $25^\circ C$ | 20 | |
| I^2t | I^2t Value for fusing | $t_p = 8.3 ms$ | 1.6 | A^2s |
| di/dt | Critical rate of rise of on-state current | $f = 60 Hz ; T_j = 110^\circ C$ | 50 | $A/\mu s$ |
| I_{GM} | Peak gate current | $T_j = 110^\circ C$ | 1 | A |
| $P_{G(AV)}$ | Average gate power dissipation | $T_j = 110^\circ C$ | 0.1 | W |
| T_{stg} | Storage temperature range | | -40 to 150 | $^\circ C$ |
| T_j | Operating junction temperature range | | -40 to 110 | $^\circ C$ |

0.8 A SCRs

Electrical Characteristics ($T_J = 25^\circ\text{C}$, unless otherwise specified)

| Symbol | Test Conditions | Value | | | | Unit | | |
|----------|---|-----------------|-----------------|---------------|-----------------|------|-----|------------------|
| | | SxS1 EC103X1 | SxS2 EC103X2 | SxS EC103X | SxS3 EC103X3 | | | |
| I_{GT} | $V_D = 12\text{V}; R_L = 60\ \Omega$ | | MAX. | 12 | 50 | 200 | 500 | μA |
| V_{GT} | | | MAX. | 0.8 | | | | V |
| dv/dt | $V_D = V_{DRM}; R_{GK} = 1\text{k}\Omega$ | 400V | MIN. | 20 | 25 | 30 | 40 | V/ μs |
| | | 600V | MIN. | 10 | 10 | 15 | 20 | |
| V_{GD} | $V_D = V_{DRM}; R_L = 3.3\text{k}\Omega; T_J = 110^\circ\text{C}$ | | MIN. | 0.2 | 0.25 | | | V |
| I_H | $I_T = 200\text{mA}$ (initial) | | MAX. | 5 | | | 8 | mA |
| t_q | (1) | | MAX. | 60 | | 50 | 45 | μs |
| t_{gt} | $I_G = 2 \times I_{GT}; \text{PW} = 15\mu\text{s}; I_T = 1.6\text{A}$ | | TYP. | 2 | 3 | 4 | 5 | μs |

(1) $I_T = 1\text{A}; t_p = 50\mu\text{s}; \text{dv/dt} = 5\text{V}/\mu\text{s}; \text{di/dt} = -5\text{A}/\mu\text{s}$

Static Characteristics

| Symbol | Test Conditions | Value | Unit |
|---------------------|---|---------------------------|-------------|
| V_{TM} | $I_T = 1.2\text{A}; t_p = 380\ \mu\text{s}$ | MAX. | 1.7 V |
| I_{DRM} / I_{RRM} | $V_{DRM} = V_{RRM}$ | $T_J = 25^\circ\text{C}$ | MAX. 1 |
| | | $T_J = 100^\circ\text{C}$ | MAX. 50 |
| | | $T_J = 110^\circ\text{C}$ | MAX. 100 |

Thermal Resistances

| Symbol | Parameter | Value | Unit |
|-------------------|-----------------------|---------|----------------------------------|
| $R_{\theta(J-C)}$ | Junction to case (AC) | EC103xy | 75 |
| | | SxSy | 60* |
| $R_{\theta(J-A)}$ | Junction to ambient | EC103xy | 160 $^\circ\text{C}/\text{W}$ |

Notes: x = voltage, y = sensitivity

* = Mounted on 1 cm² copper (two-ounce) foil surface

Soldering Parameters

| | | |
|--|------------------------------------|-------------------------|
| Reflow Condition | | Pb – Free assembly |
| Pre Heat | - Temperature Min ($T_{s(min)}$) | 150°C |
| | - Temperature Max ($T_{s(max)}$) | 200°C |
| | - Time (min to max) (t_s) | 60 – 190 secs |
| Average ramp up rate (Liquidus Temp (T_L) to peak) | | 5°C/second max |
| $T_{s(max)}$ to T_L - Ramp-up Rate | | 5°C/second max |
| Reflow | - Temperature (T_L) (Liquidus) | 217°C |
| | - Temperature (t_L) | 60 – 150 seconds |
| Peak Temperature (T_p) | | 260 ^{+0/-5} °C |
| Time within 5°C of actual peak Temperature (t_p) | | 20 – 40 seconds |
| Ramp-down Rate | | 5°C/second max |
| Time 25°C to peak Temperature (T_p) | | 8 minutes Max. |
| Do not exceed | | 280°C |

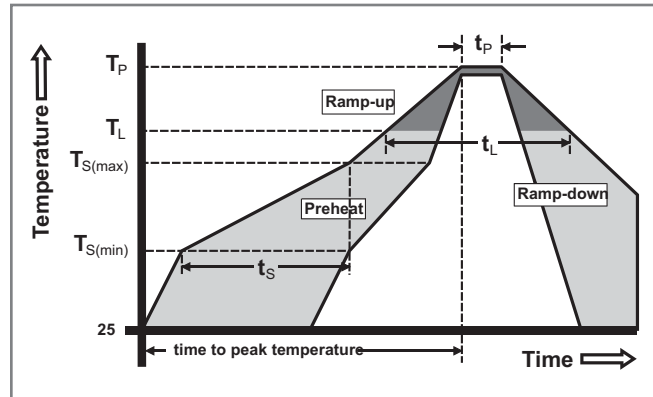

Physical Specifications

| | |
|------------------------|---|
| Terminal Finish | 100% Matte Tin-plated/Pb-free Solder Dipped |
| Body Material | UL recognized epoxy meeting flammability classification 94V-0 |
| Lead Material | Copper Alloy |

Design Considerations

Careful selection of the correct device for the application's operating parameters and environment will go a long way toward extending the operating life of the Thyristor. Good design practice should limit the maximum continuous current through the main terminals to 75% of the device rating. Other ways to ensure long life for a power discrete semiconductor are proper heat sinking and selection of voltage ratings for worst case conditions. Overheating, overvoltage (including dv/dt), and surge currents are the main killers of semiconductors. Correct mounting, soldering, and forming of the leads also help protect against component damage.

Environmental Specifications

| Test | Specifications and Conditions |
|----------------------------------|---|
| AC Blocking | MIL-STD-750, M-1040, Cond A Applied Peak AC voltage @ 110°C for 1008 hours |
| Temperature Cycling | MIL-STD-750, M-1051, 100 cycles; -40°C to +150°C; 15-min dwell-time |
| Temperature/Humidity | EIA / JEDEC, JESD22-A101 1008 hours; 320V - DC: 85°C; 85% rel humidity |
| High Temp Storage | MIL-STD-750, M-1031, 1008 hours; 150°C |
| Low-Temp Storage | 1008 hours; -40°C |
| Thermal Shock | MIL-STD-750, M-1056 10 cycles; 0°C to 100°C; 5-min dwell-time at each temperature; 10 sec (max) transfer time between temperature |
| Autoclave | EIA / JEDEC, JESD22-A102 168 hours (121°C at 2 ATMs) and 100% R/H |
| Resistance to Solder Heat | MIL-STD-750 Method 2031 |
| Solderability | ANSI/J-STD-002, category 3, Test A |
| Lead Bend | MIL-STD-750, M-2036 Cond E |

Dimensions – TO-92 (E Package)

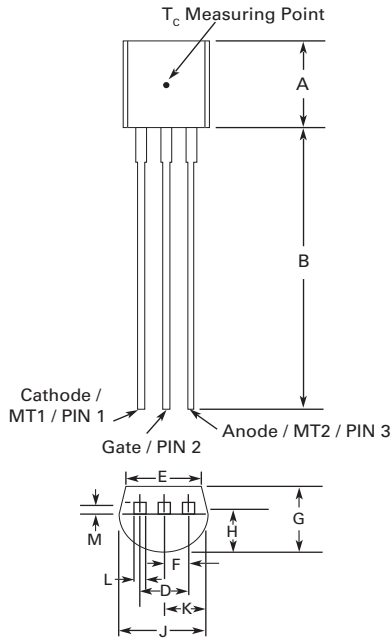

| Dimension | Inches | | Millimeters | |
|-----------|--------|-------|-------------|------|
| | Min | Max | Min | Max |
| A | 0.176 | 0.196 | 4.47 | 4.98 |
| B | 0.500 | - | 12.70 | - |
| D | 0.095 | 0.105 | 2.41 | 2.67 |
| E | 0.150 | - | 3.81 | - |
| F | 0.046 | 0.054 | 1.16 | 1.37 |
| G | 0.135 | 0.145 | 3.43 | 3.68 |
| H | 0.088 | 0.096 | 2.23 | 2.44 |
| J | 0.176 | 0.186 | 4.47 | 4.73 |
| K | 0.088 | 0.096 | 2.23 | 2.44 |
| L | 0.013 | 0.019 | 0.33 | 0.48 |
| M | 0.013 | 0.017 | 0.33 | 0.43 |

All leads insulated from case. Case is electrically nonconductive.

Dimensions — Compak (C Package)

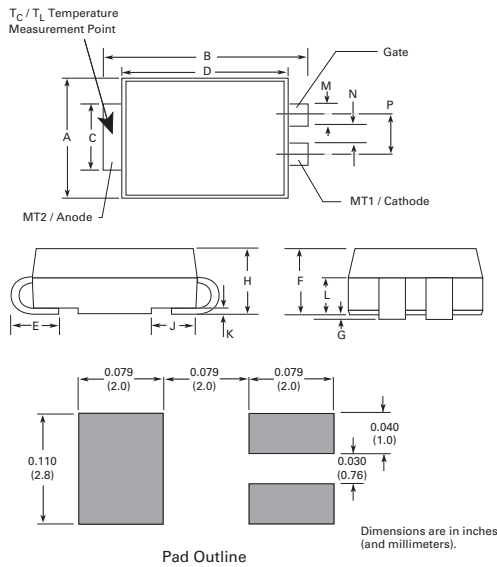

| Dimension | Inches | | Millimeters | |
|-----------|--------|-------|-------------|------|
| | Min | Max | Min | Max |
| A | 0.140 | 0.155 | 3.56 | 3.94 |
| B | 0.205 | 0.220 | 5.21 | 5.59 |
| C | 0.077 | 0.083 | 1.96 | 2.11 |
| D | 0.166 | 0.180 | 4.22 | 4.57 |
| E | 0.036 | 0.063 | 0.91 | 1.60 |
| F | 0.066 | 0.083 | 1.67 | 2.11 |
| G | 0.004 | 0.008 | 0.10 | 0.20 |
| H | 0.077 | 0.086 | 1.96 | 2.18 |
| J | 0.043 | 0.053 | 1.09 | 1.35 |
| K | 0.008 | 0.012 | 0.20 | 0.30 |
| L | 0.039 | 0.049 | 0.99 | 1.24 |
| M | 0.022 | 0.028 | 0.56 | 0.71 |
| N | 0.027 | 0.033 | 0.69 | 0.84 |
| P | 0.052 | 0.058 | 1.32 | 1.47 |

0.8 A SCRs

Product Selector

| Part Number | Voltage | | | | Gate Sensitivity | Type | Package |
|-------------|---------|------|------|-------|------------------|---------------|---------|
| | 400V | 600V | 800V | 1000V | | | |
| EC103 x 1 | X | X | | | 12µA | Sensitive SCR | TO-92 |
| EC103 x 2 | X | X | | | 50µA | Sensitive SCR | TO-92 |
| EC103 x | X | X | | | 200µA | Sensitive SCR | TO-92 |
| EC103 x 3 | X | X | | | 500µA | Sensitive SCR | TO-92 |
| S x S1 | X | X | | | 12µA | Sensitive SCR | Compak |
| S x S2 | X | X | | | 50µA | Sensitive SCR | Compak |
| S x S | X | X | | | 200µA | Sensitive SCR | Compak |
| S x S3 | X | X | | | 500µA | Sensitive SCR | Compak |

Note: x = Voltage

Packing Options

| Part Number | Marking | Weight | Packing Mode | Base Quantity |
|-------------|---------|--------|------------------|---------------|
| EC103xy | EC103xy | 0.19 g | Bulk | 2000 |
| EC103xyRP | EC103xy | 0.19 g | Reel Pack | 2000 |
| EC103xyAP | EC103xy | 0.19 g | Ammo Pack | 2000 |
| SxSyRP | SxSy | 0.08 g | Embossed Carrier | 2500 |

Note: x = Voltage, y = sensitivity

TO-92 (3-lead) Reel Pack (RP) Radial Leaded Specifications

Meets all EIA-468-B 1994 Standards

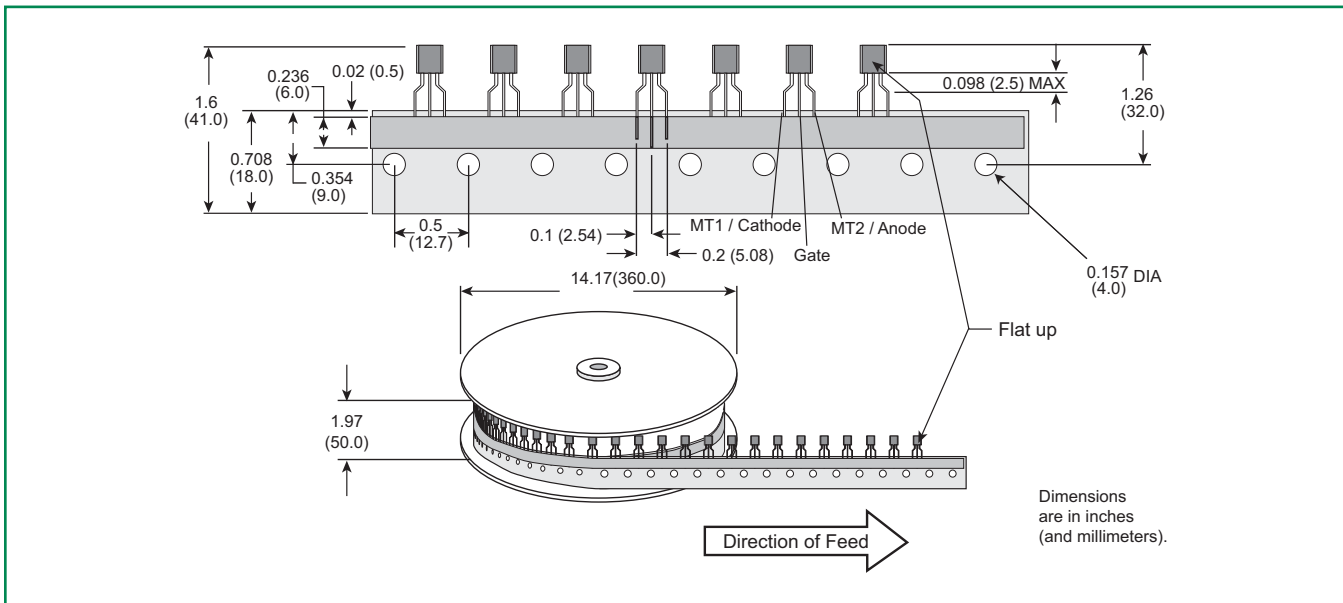

TO-92 (3-lead) Ammo Pack (AP) Radial Leaded Specifications

Meets all EIA-468-B 1994 Standards

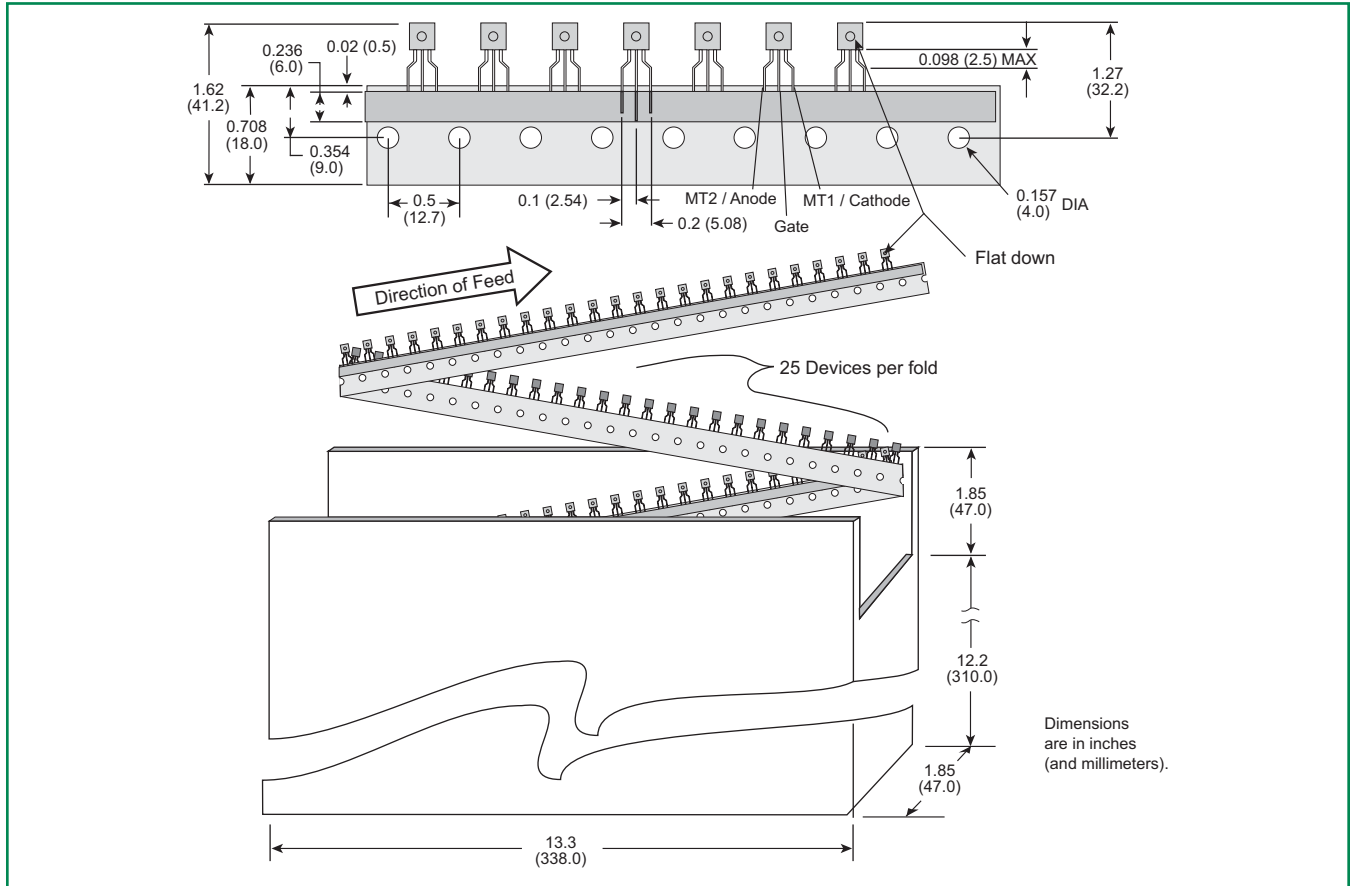

Compak Embossed Carrier Reel Pack (RP) Specifications

Meets all EIA-481-1 Standards

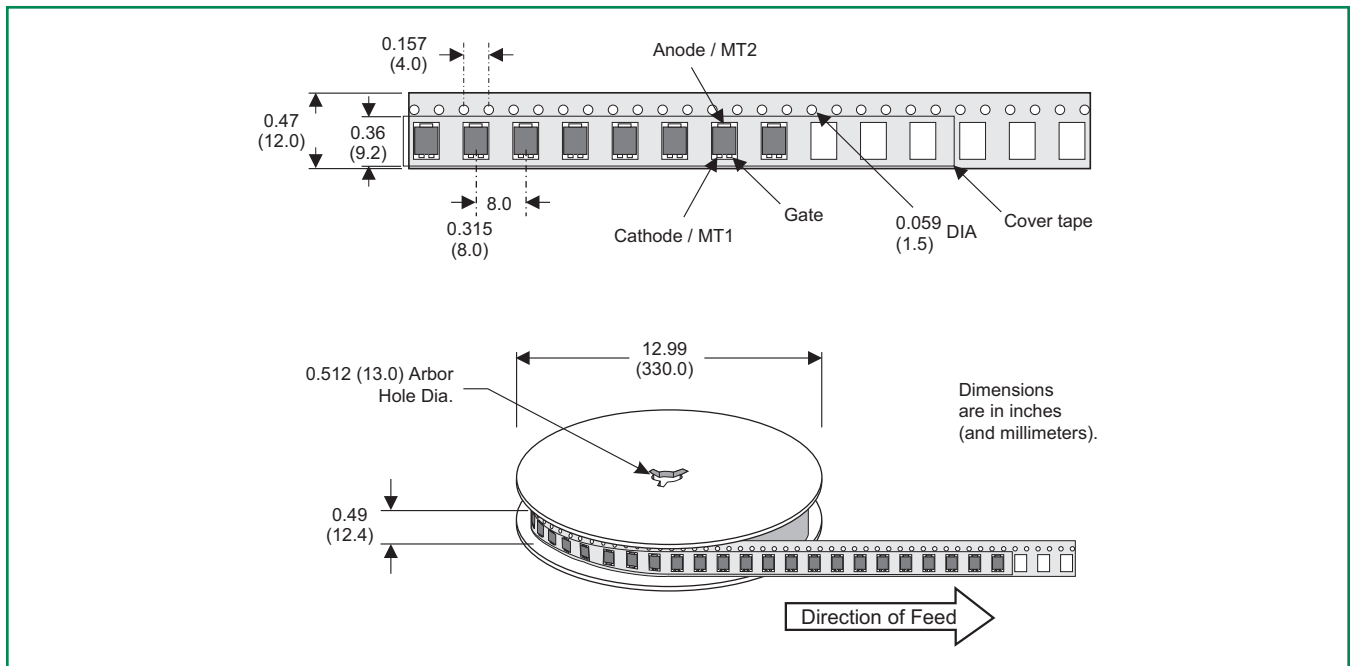

0.8 A SCRs

Part Numbering System (TO-92)

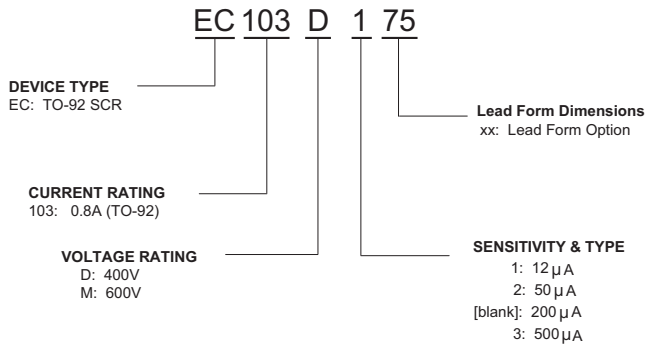

Part Marking System

TO-92 (E Package)

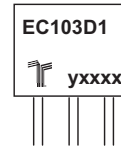

Part Numbering System (Compak)

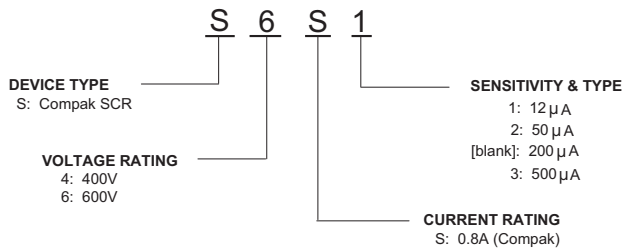

Part Marking System (Compak)

Compak (C Package)

