

LM185-2.5/LM285-2.5/LM385-2.5 Micropower Voltage Reference Diode

General Description

The LM185-2.5/LM285-2.5/LM385-2.5 are micropower 2-terminal band-gap voltage regulator diodes. Operating over a 20 μ A to 20 mA current range, they feature exceptionally low dynamic impedance and good temperature stability. On-chip trimming is used to provide tight voltage tolerance. Since the LM-185-2.5 band-gap reference uses only transistors and resistors, low noise and good long term stability result.

Careful design of the LM185-2.5 has made the device exceptionally tolerant of capacitive loading, making it easy to use in almost any reference application. The wide dynamic operating range allows its use with widely varying supplies with excellent regulation.

The extremely low power drain of the LM185-2.5 makes it useful for micropower circuitry. This voltage reference can be used to make portable meters, regulators or general purpose analog circuitry with battery life approaching shelf life. Further, the wide operating current allows it to replace older references with a tighter tolerance part. For applications requiring 1.2V see LM185-1.2.

The LM185-2.5 is rated for operation over a -55°C to 125°C temperature range while the LM285-2.5 is rated -40°C to 85°C and the LM385-2.5 0°C to 70°C . The LM185-2.5/LM285-2.5 are available in a hermetic TO-46 package and the LM285-2.5/LM385-2.5 are also available in a low-cost TO-92 molded package, as well as S.O. and SOT-23. The LM185-2.5 is also available in a hermetic leadless chip carrier package.

Features

- ± 20 mV ($\pm 0.8\%$) max. initial tolerance (A grade)
- Operating current of 20 μ A to 20 mA
- 0.6 Ω dynamic impedance (A grade)
- Low temperature coefficient
- Low voltage reference—2.5V
- 1.2V device and adjustable device also available—LM185-1.2 series and LM185 series, respectively

Connection Diagrams

TO-92
Plastic Package

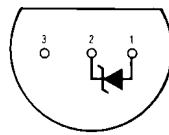

551908

Bottom View

Order Number LM285Z-2.5,
LM285BXZ-2.5, LM285BYZ-2.5
LM385Z-2.5, LM385AXZ-2.5
LM385AYZ-2.5, LM385BZ-2.5,
LM385BXZ-2.5 or LM385BYZ-2.5
See NS Package Number Z03A

SO Package

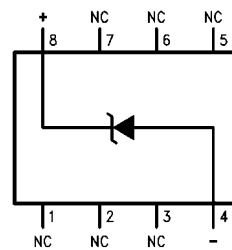

551911

Order Number LM285M-2.5,
LM285BXM-2.5, LM285BYM-2.5
LM385M-2.5, LM385BM-2.5
LM385BXM-2.5 or LM385BYM-2.5
See NS Package Number M08A

SOT-23

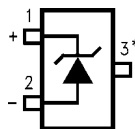

551929

* Pin 3 is attached to the Die Attach Pad (DAP) and should be connected to Pin 2 or left floating.

Order Number LM385M3-2.5
See NS Package Number MA03B

Absolute Maximum Ratings (Notes 1, 2)

If Military/Aerospace specified devices are required, please contact the National Semiconductor Sales Office/Distributors for availability and specifications.

Reverse Current	30 mA
Forward Current	10 mA
Operating Temperature Range (Note 3)	
LM185-2.5	-55°C to + 125°C
LM285-2.5	-40°C to + 85°C
LM385-2.5	0°C to 70°C

ESD Susceptibility (Note 9)	2kV
Storage Temperature	-55°C to + 150°C
Soldering Information	
TO-92 Package (10 sec.)	260°C
TO-46 Package (10 sec.)	300°C
SO and SOT Package	
Vapor Phase (60 sec.)	215°C
Infrared (15 sec.)	220°C

See AN-450 "Surface Mounting Methods and Their Effect on Product Reliability" for other methods of soldering surface mount devices.

Electrical Characteristics

(Note 4)

Parameter	Conditions	Typ	LM385A-2.5 LM385AX-2.5 LM385AY-2.5		Units (Limits)
			Tested Limit (Note 5)	Design Limit (Note 6)	
Reverse Breakdown Voltage	$I_R = 100 \mu A$	2.500	2.480		V(Min)
		2.500	2.520	2.470 2.530	V(Max) V(Min) V(Max)
Minimum Operating Current		12	18	20	μA (Max)
Reverse Breakdown Voltage Change with Current	$I_{MIN} \leq I_R \leq 1 mA$		1	1.5	mV (Max)
	$1 mA \leq I_R \leq 20 mA$		10	20	mV (Max)
Reverse Dynamic Impedance	$I_R = 100 \mu A,$ $f = 20 Hz$	0.2		0.6	Ω
				1.5	
Wideband Noise (rms)	$I_R = 100 \mu A$ $10 Hz \leq f \leq 10 kHz$	120			μV
Long Term Stability	$I_R = 100 \mu A,$ $T = 1000 Hr,$ $T_A = 25^\circ C \pm 0.1^\circ C$	20			ppm
Average Temperature Coefficient (Note 7)	$I_{MIN} \leq I_R \leq 20 mA$ X Suffix Y Suffix All Others			30	ppm/°C (Max)
				50	
				150	

Electrical Characteristics

Parameter	Conditions	Typ	LM185-2.5 LM185BX-2.5 LM185BY-2.5 LM285-2.5 LM285BX-2.5 LM285BY-2.5		LM385B-2.5 LM385BX-2.5 LM385BY-2.5		LM385-2.5		Units (Limit)
			Tested Limit (Notes 5, 8)	Design Limit (Note 6)	Tested Limit (Note 5)	Design Limit (Note 6)	Tested Limit (Note 5)	Design Limit (Note 6)	
Reverse Breakdown Voltage	$T_A = 25^\circ\text{C}$,	2.5	2.462		2.462		2.425		V(Min)
	$20\ \mu\text{A} \leq I_R \leq 20\ \text{mA}$		2.538		2.538		2.575		V(Max)
Minimum Operating Current		13	20	30	20	30	20	30	μA
	LM385M3-2.5						15	20	(Max)
Reverse Breakdown Voltage Change with Current	$20\ \mu\text{A} \leq I_R \leq 1\ \text{mA}$		1	1.5	2.0	2.5	2.0	2.5	mV (Max)
	$1\ \text{mA} \leq I_R \leq 20\ \text{mA}$		10	20	20	25	20	25	mV (Max)
Reverse Dynamic Impedance	$I_R = 100\ \mu\text{A}$, $f = 20\ \text{Hz}$	1							Ω
Wideband Noise (rms)	$I_R = 100\ \mu\text{A}$, $10\ \text{Hz} \leq f \leq 10\ \text{kHz}$	120							μV
Long Term Stability	$I_R = 100\ \mu\text{A}$, $T = 1000\ \text{Hr}$, $T_A = 25^\circ\text{C} \pm 0.1^\circ\text{C}$	20							ppm
Average Temperature Coefficient (Note 7)	$I_R = 100\ \mu\text{A}$								
	X Suffix		30		30				ppm/ $^\circ\text{C}$
	Y Suffix		50	150	50	150	150	150	ppm/ $^\circ\text{C}$ ppm/ $^\circ\text{C}$ (Max)
All Others									

Note 1: Absolute Maximum Ratings indicate limits beyond which damage to the device may occur. Operating Ratings indicate conditions for which the device is intended to be functional, but do not guarantee specific performance limits. For guaranteed specifications and test conditions, see the Electrical Characteristics. The guaranteed specifications apply only for the test conditions listed.

Note 2: Refer to RETS185H-2.5 for military specifications.

Note 3: For elevated temperature operation, $T_{J\text{MAX}}$ is:

LM185	150°C
LM285	125°C
LM385	100°C

Thermal Resistance	TO-92	TO-46	SO-8	SOT-23
θ_{ja} (Junction to Ambient)	180°C/W (0.4 Leads) 170°C/W (0.125 Leads)	440°C/W	165°C/W	283°C/W
θ_{jc} (Junction to Case)	N/A	80°C/W	N/A	N/A

Note 4: Parameters identified with boldface type apply at temperature extremes. All other numbers apply at $T_A = T_J = 25^\circ\text{C}$.

Note 5: Guaranteed and 100% production tested.

Note 6: Guaranteed, but not 100% production tested. These limits are not used to calculate average outgoing quality levels.

Note 7: The average temperature coefficient is defined as the maximum deviation of reference voltage at all measured temperatures between the operating T_{MAX} and T_{MIN} , divided by $T_{\text{MAX}} - T_{\text{MIN}}$. The measured temperatures are -55°C , -40°C , 0°C , 25°C , 70°C , 85°C , 125°C .

Note 8: A military RETS electrical specification available on request.

Note 9: The human body model is a 100 pF capacitor discharged through a 1.5 k Ω resistor into each pin.

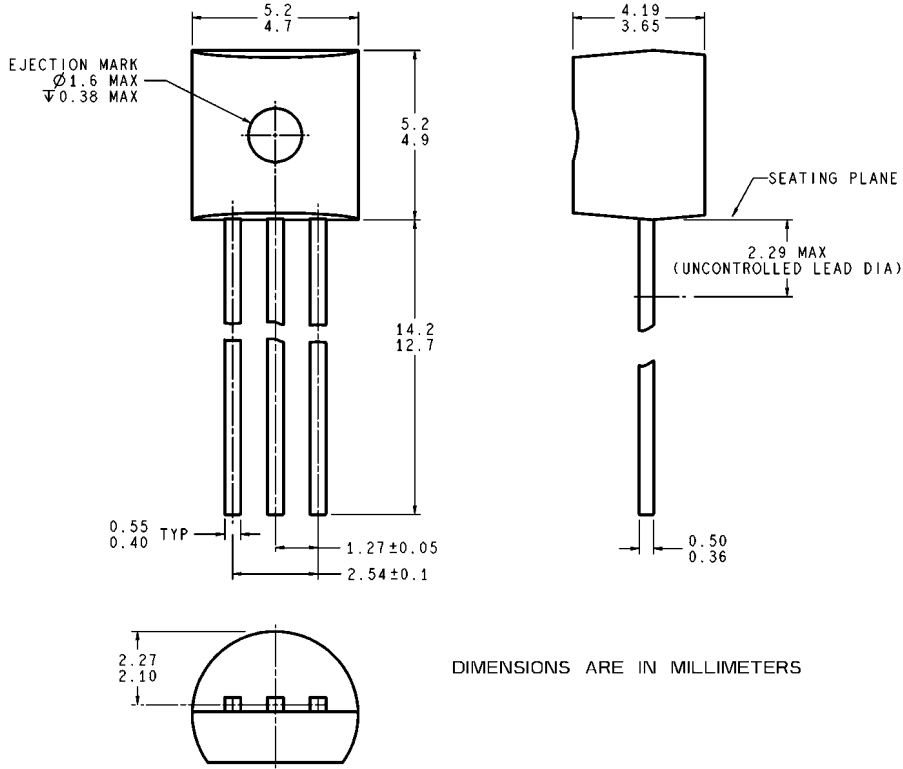

DIMENSIONS ARE IN MILLIMETERS

Z03A (Rev G)

TO-92 Plastic Package (Z)
Order Number LM285Z-2.5, LM285BXZ-2.5, LM285BYZ-2.5,
LM385Z-2.5, LM385AXZ-2.5, LM385AYZ-2.5,
LM385BZ-2.5, LM385BXZ-2.5 or LM385BYZ-2.5
NS Package Number Z03A