



Date	DRN BY
8-26-09	MEA
MAT'L	SCALE
STEEL	NONE

TITLE	SMALL CHARGER CLIP
CURRENT RATING:	50 AMP

ISSUE NO.	0	1							
	8-26-09	9-9-09							

PART NO.	501774
PROJ. NO.	

This drawing is not to be disclosed to a third party without the authority from the company ©

FEDERAL SPEC : CID AA59466-010

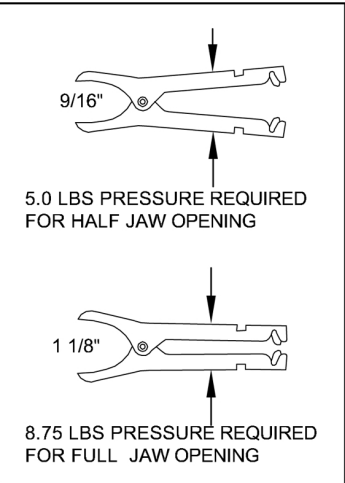

SPRING TESTED PER
FED. SPEC. #WC440B
FORCE APPLIED ON THE
CENTER OF SPRING AXIS
FINISH: COPPER PLATED

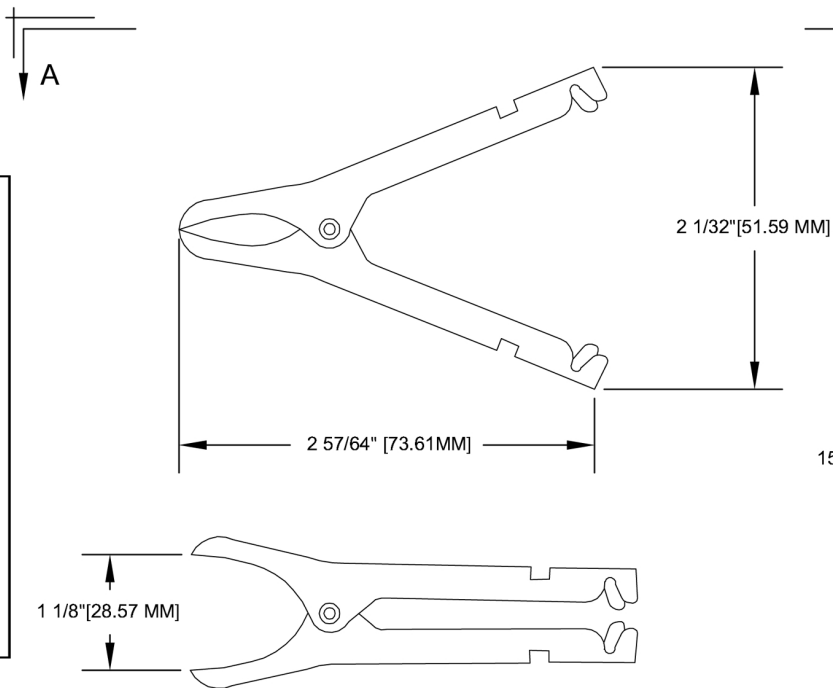

501774_B = 501774 CLIP & 400010_B INSULATORS INSTALLED
501774_R = 501774 CLIP & 400010_R INSULATORS INSTALLED

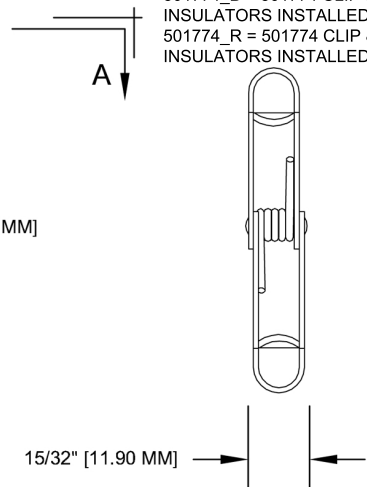

SECTION A-A

ASSEMBLY NO.	PACKAGING :	PRINTING AS ILLUSTRATED	CONCENTRICITY:	ANGLES
--------------	-------------	-------------------------	----------------	--------