

15 Amp - Industrial/Commercial Grade

1584 Series

Key Features

- Built to meet the rugged requirements of commercial and industrial use.
- All metal housing - tough extruded aluminum case with a black powder paint coated steel cover.
- Heavy duty receptacles.
- Heavy 14 gauge wire cord - 14/3 SJT or SJWT for extreme temperature ranges and integral molded plug.
- Plug types available are NEMA 5-15P straight blade or NEMA L5-15P twist-lock (see table below).
- Mounting feet (with keyhole slots) allow temporary work station mounting if desired.
- On-Off switch is rocker type with light (on those units with on-off switch - listed below) or a red pilot light to indicate power on.
- Includes 15 amp, 125 volt resettable circuit breaker to prevent accidental line overload.
- CSA certified, Standards C22.2 (No. 21-95 and No. 42-99)
- UL listed, Standard UL1363
- Surge Protected models also available - please see the 1584 "S" models on **page 25**



Outlet Strips



Part No.	Outlets	On-Off Switch	Pilot Light	Cord Length	Plug Type	Dimensions (inches)
1584H4A1	4	Yes	-	6'	Straight	11 x 2 x 2
1584H4B1	4	Yes	-	15'	Straight	11 x 2 x 2
1584H4C1	4	Yes	-	6'	Twist-Lock	11 x 2 x 2
1584H4D1	4	Yes	-	15'	Twist-Lock	11 x 2 x 2
1584H5A1	5	Yes	-	6'	Straight	14 x 2 x 2
1584H5B1	5	Yes	-	15'	Straight	14 x 2 x 2
1584H5C1	5	Yes	-	6'	Twist-Lock	14 x 2 x 2
1584H5D1	5	Yes	-	15'	Twist-Lock	14 x 2 x 2
1584H6A1	6	Yes	-	6'	Straight	14 x 2 x 2
1584H6B1	6	Yes	-	15'	Straight	14 x 2 x 2
1584H6C1	6	Yes	-	6'	Twist-Lock	14 x 2 x 2
1584H6D1	6	Yes	-	15'	Twist-Lock	14 x 2 x 2
1584H7A1	7	Yes	-	6'	Straight	17 x 2 x 2
1584H7B1	7	Yes	-	15'	Straight	17 x 2 x 2
1584H7C1	7	Yes	-	6'	Twist-Lock	17 x 2 x 2
1584H7D1	7	Yes	-	15'	Twist-Lock	17 x 2 x 2
1584H8A1	8	Yes	-	6'	Straight	17 x 2 x 2
1584H8B1	8	Yes	-	15'	Straight	17 x 2 x 2
1584H8C1	8	Yes	-	6'	Twist-Lock	17 x 2 x 2
1584H8D1	8	Yes	-	15'	Twist-Lock	17 x 2 x 2
1584T4A1	4	-	Yes	6'	Straight	11 x 2 x 2
1584T4B1	4	-	Yes	15'	Straight	11 x 2 x 2
1584T4C1	4	-	Yes	6'	Twist-Lock	11 x 2 x 2
1584T4D1	4	-	Yes	15'	Twist-Lock	11 x 2 x 2
1584T5A1	5	-	Yes	6'	Straight	14 x 2 x 2
1584T5B1	5	-	Yes	15'	Straight	14 x 2 x 2
1584T5C1	5	-	Yes	6'	Twist-Lock	14 x 2 x 2
1584T5D1	5	-	Yes	15'	Twist-Lock	14 x 2 x 2
1584T6A1	6	-	Yes	6'	Straight	14 x 2 x 2
1584T6B1	6	-	Yes	15'	Straight	14 x 2 x 2
1584T6C1	6	-	Yes	6'	Twist-Lock	14 x 2 x 2
1584T6D1	6	-	Yes	15'	Twist-Lock	14 x 2 x 2
1584T7A1	7	-	Yes	6'	Straight	17 x 2 x 2
1584T7B1	7	-	Yes	15'	Straight	17 x 2 x 2
1584T7C1	7	-	Yes	6'	Twist-Lock	17 x 2 x 2
1584T7D1	7	-	Yes	15'	Twist-Lock	17 x 2 x 2
1584T8A1	8	-	Yes	6'	Straight	17 x 2 x 2
1584T8B1	8	-	Yes	15'	Straight	17 x 2 x 2
1584T8C1	8	-	Yes	6'	Twist-Lock	17 x 2 x 2
1584T8D1	8	-	Yes	15'	Twist-Lock	17 x 2 x 2

Also Available (by special order) - change to a 90 degree Nema 5-15P plug on 1584 models ending in 'A1' or 'B1'.

NOTES

BUILT TO MEET THE REQUIREMENTS OF INDUSTRIAL AND COMMERCIAL USE. ALL METAL HOUSING—TOUGH EXTRUDED ALUMINUM CASE WITH BLACK POWDER-COATED STEEL COVER.
 HEAVY-DUTY CORD — 14/3 SJTW WIRE FOR EXTREME TEMPERATURE RANGES.
 INTEGRAL MOLDED PLUG AVAILABLE IN STRAIGHT-BLADE (NEMA 5-15P) OR TWIST-LOCK (NEMA L5-15P) CONFIGURATIONS.
 SEPARATE MOUNTING FEET WITH KEYHOLE SLOTS PROVIDE FOR WORK STATION MOUNTING IF DESIRED.
 COMES WITH LIGHTED ON/OFF SWITCH.
 INCLUDES 15A, 125VAC CIRCUIT BREAKER TO PREVENT ACCIDENTAL LINE OVERLOAD.
 CSA CERTIFIED, UL 1363 LISTED.

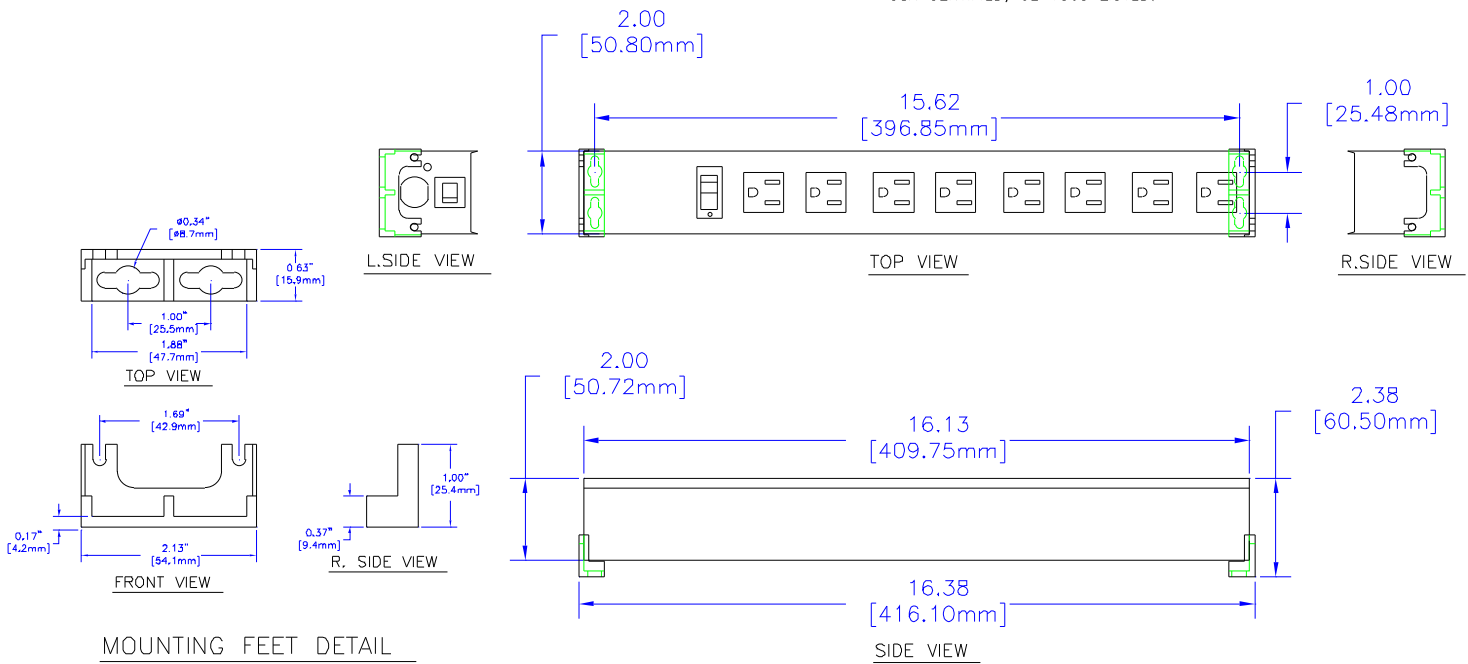

*SEE CATALOG FOR THE COMPLETE PART NUMBER BASED ON THE OPTIONS LISTED IN THE NOTE SECTION

UNLESS OTHERWISE SPECIFIED DIMENSIONS ARE IN INCHES	
F	+/- .02
XX	+/- .015
XXX	+/- .010
XXXX	+/- .005
ANGLES	+/- .5 DEG



HAMMOND MANUFACTURING

TITLE HAMMOND INDUSTRIAL GRADE POWER STRIPS	
DRAWN BY MJM	PAGE 1 OF 1
PART NUMBER 1584H8****	