



LM393 - Low Power Low Offset Voltage Dual Comparator

Features

Typical Application

Wide supply

Voltage range:	2.0V to 36V
Single or dual supplies:	±1.0V to ±18V

Very low supply current drain (0.4 mA) - independent of supply voltage	
Low input biasing current:	25 nA
Low input offset current:	±5 nA
Maximum offset voltage:	±3 mV
Input common-mode voltage range includes ground	
Differential input voltage range equal to the power supply voltage	
Low output saturation voltage,,:	250 mV at 4 mA
Output voltage compatible with TTL, DTL, ECL, MOS and CMOS logic systems	
Available in the 8-Bump (12 mil) micro SMD package	
See AN-1112 for micro SMD considerations	

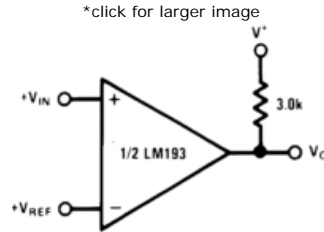

Parametric Table

Response Time	0.4 us
Output Bus	Open Drain
Supply Min	2 Volt
Supply Max	36 Volt
Channels	2 Channels
Offset Voltage max, 25C	5 mV
Output Current	16 mA
Input Range	Vcm to V-
Supply Current Per Channel	0.2 mA
PowerWise Rating 3	80 uA x us
Max Input Bias Current	400 nA
Special Features	Undefined
Temperature Min	0 deg C
Temperature Max	70 deg C
Function	Comparator
AEC Q-100 Automotive Grade	0

Connection Diagram

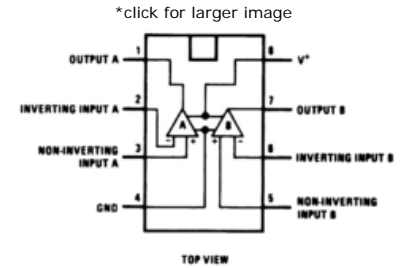

Typical Performance

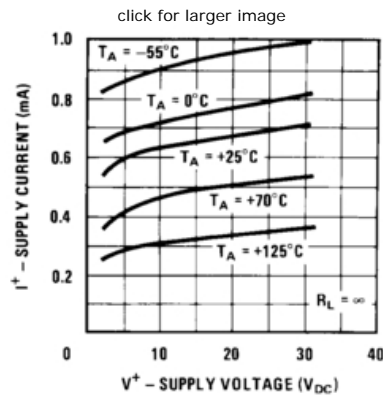

Applications

- High precision comparators
- Reduced V_{OS} drift over temperature
- Eliminates need for dual supplies
- Allows sensing near ground
- Compatible with all forms of logic
- Power drain suitable for battery operation



RoHS Compliance Information

LM193/LM293/LM393/LM2903 Low Power Low Offset Voltage Dual Comparators
 LM193/LM293/LM393/LM2903 Low Power Low Offset Voltage Dual Comparators (Japanese)

If you have trouble printing or viewing PDF file(s), see [Printing Problems](#).

Package Availability, Models, Samples & Pricing

Part Number	Package						Factory Lead Time		Models			Std Pack Size	Package Marking Format
	Type	Pins	Spec.	MSL Rating	Peak Reflow	RoHS Report	Weeks	Qty					
LM393M	SOIC NARROW	8	STD	1	235	RoHS	Full production		N/A			rail of 95	NSZXTT LM 393M
			NOPB	1	260		6 weeks	5000					
LM393MX	SOIC NARROW	8	STD	1	235	RoHS	Full production		N/A			reel of 2500	NSZXTT LM 393M
			NOPB	1	260		6 weeks	7500					
LM393N	MDIP	8	STD	1	NA	RoHS	Full production		N/A			rail of 40	NSUZXYTT LM 393N
			NOPB	1	NA		6 weeks	5000					
LM393TL	MICRO SMD	8	NOPB	1	260	RoHS	Full production		N/A			reel of 250	XVC I 02
							12 weeks	2000					
LM393TLX	MICRO SMD	8	STD	1	260	RoHS	Full production		N/A			reel of 3000	XVC I 02
			NOPB	1	260		6 weeks	200000					
LM393H	TO-99	8	NOPB	1	NA	RoHS	Lifetime buy		N/A			box of 500	NSZXYTTE# LM393H
							6 weeks	1000					
LM393 MDC	Unpackaged Die						Full production		N/A			tray of N/A	-
							N/A	N/A					
LM393 MWC	Wafer						Lifetime buy		N/A			wafer jar of N/A	-
							N/A	100000					

Obsolete Versions

Obsolete Part	Alternate Part or Supplier	Source	Last Time Buy Date
LM393AH	LM2903	NSC	09/08/99
LM393AJ	LM393N	NATIONAL SEMICONDUCTOR	12/07/93
LM393H	LM193AH	National Semiconductor	12/01/2009
LM393H	LM193H	National Semiconductor	12/01/2009
LM393J	LM393N	NATIONAL SEMICONDUCTOR	12/07/93

General Description

The LM193 series consists of two independent precision voltage comparators with an offset voltage specification as low as 2.0 mV max for two comparators which were designed specifically to operate from a single power supply over a wide range of voltages. Operation from split power supplies is also possible and the low power supply current drain is independent of the magnitude of the power supply voltage. These comparators also have a unique characteristic in that the input common-mode voltage range includes ground, even though operated from a single power supply voltage.

Application areas include limit comparators, simple analog to digital converters; pulse, squarewave and time delay generators; wide range VCO; MOS clock timers; multivibrators and high voltage digital logic gates. The LM193 series was designed to directly interface with TTL and CMOS. When operated from both plus and minus power supplies, the LM193 series will directly interface with MOS logic where their low power drain is a distinct advantage over standard comparators.

The LM393 and LM2903 parts are available in National's innovative thin micro SMD package with 8 (12 mil) large bumps.

Reliability Metrics

Part Number	Process	EFR Reject	EFR Sample Size	PPM *	LTA Rejects	LTA Device Hours	FITS	MTTF (Hours)
LM393M	SLM	0	42786	0	0	3352500	2	951281028
LM393MX	SLM	0	42786	0	0	3352500	2	951281028
LM393N	SLM	0	42786	0	0	3352500	2	951281028
LM393TL	SLM	0	42786	0	0	3352500	2	951281028
LM393TLX	SLM	0	42786	0	0	3352500	2	951281028

Note: The Early Failure Rates were calculated as point estimates. The Long Term Failure Rates were calculated at 60% confidence using the Arrhenius equation at 0.7eV activation energy and derating the assumed stress temperature of 150°C to an application temperature of 55°C.

LM193/LM293/LM393/LM2903

Low Power Low Offset Voltage Dual Comparators

General Description

The LM193 series consists of two independent precision voltage comparators with an offset voltage specification as low as 2.0 mV max for two comparators which were designed specifically to operate from a single power supply over a wide range of voltages. Operation from split power supplies is also possible and the low power supply current drain is independent of the magnitude of the power supply voltage. These comparators also have a unique characteristic in that the input common-mode voltage range includes ground, even though operated from a single power supply voltage.

Application areas include limit comparators, simple analog to digital converters; pulse, squarewave and time delay generators; wide range VCO; MOS clock timers; multivibrators and high voltage digital logic gates. The LM193 series was designed to directly interface with TTL and CMOS. When operated from both plus and minus power supplies, the LM193 series will directly interface with MOS logic where their low power drain is a distinct advantage over standard comparators.

The LM393 and LM2903 parts are available in National's innovative thin micro SMD package with 8 (12 mil) large bumps.

Advantages

- High precision comparators
- Reduced V_{OS} drift over temperature
- Eliminates need for dual supplies
- Allows sensing near ground
- Compatible with all forms of logic
- Power drain suitable for battery operation

Features

- Wide supply
 - Voltage range: 2.0V to 36V
 - Single or dual supplies: $\pm 1.0V$ to $\pm 18V$
- Very low supply current drain (0.4 mA) — independent of supply voltage
- Low input biasing current: 25 nA
- Low input offset current: ± 5 nA
- Maximum offset voltage: ± 3 mV
- Input common-mode voltage range includes ground
- Differential input voltage range equal to the power supply voltage
- Low output saturation voltage, : 250 mV at 4 mA
- Output voltage compatible with TTL, DTL, ECL, MOS and CMOS logic systems
- Available in the 8-Bump (12 mil) micro SMD package
- See AN-1112 for micro SMD considerations

Squarewave Oscillator

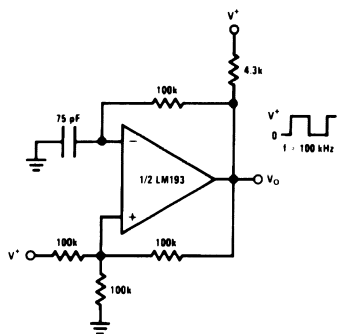

00570938

Non-Inverting Comparator with Hysteresis

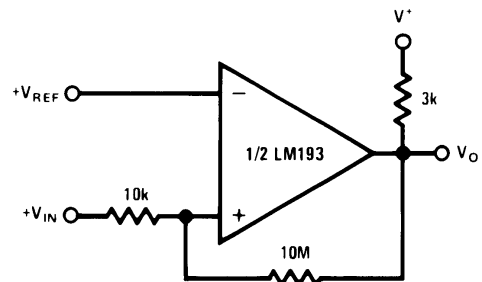

00570909

Schematic and Connection Diagrams

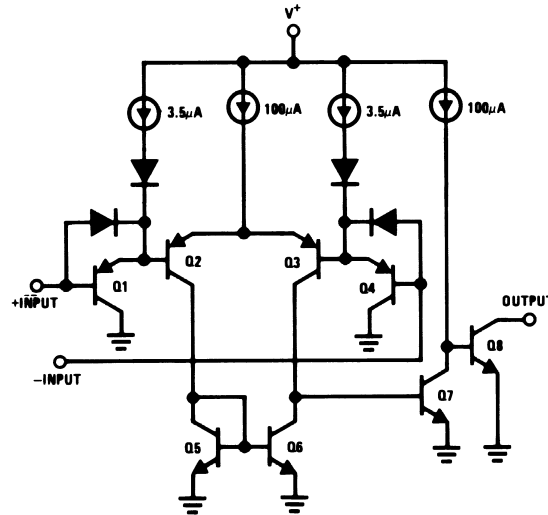

00570902

Metal Can Package

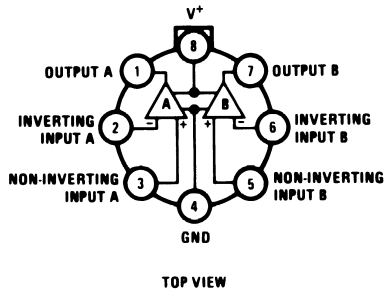

00570903

Dual-In-Line/SOIC Package

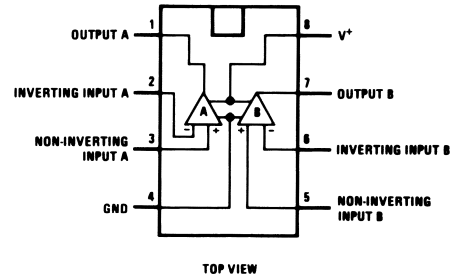

00570901

micro SMD

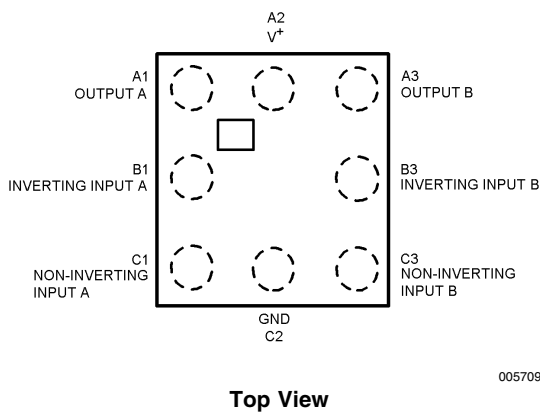

00570945

micro SMD Marking

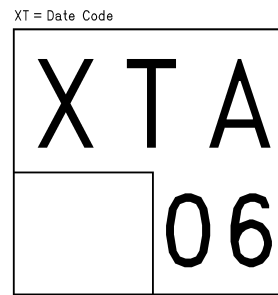

Pin A1 Corner
Pin A1 is identified by lower left corner with respect to the text.

Top View

00570946

Absolute Maximum Ratings (Note 10)

If Military/Aerospace specified devices are required, please contact the National Semiconductor Sales Office/Distributors for availability and specifications.

Supply Voltage, V ⁺	36V
Differential Input Voltage (Note 8)	36V
Input Voltage	-0.3V to +36V
Input Current (V _{IN} < -0.3V) (Note 3)	50 mA
Power Dissipation (Note 1)	
Molded DIP	780 mW
Metal Can	660 mW
Small Outline Package	510 mW
micro SMD Package	568mW
Output Short-Circuit to Ground (Note 2)	Continuous
Operating Temperature Range	
LM393	0°C to +70°C
LM293	-25°C to +85°C

LM193/LM193A	-55°C to +125°C
LM2903	-40°C to +85°C
Storage Temperature Range	-65°C to +150°C
Lead Temperature (Soldering, 10 seconds)	+260°C
Soldering Information	
Dual-In-Line Package	
Soldering (10 seconds)	260°C
Small Outline Package	215°C
Vapor Phase (60 seconds)	
Infrared (15 seconds)	220°C
See AN-450 "Surface Mounting Methods and Their Effect on Product Reliability" for other methods of soldering surface mount devices.	
ESD rating (1.5 kΩ in series with 100 pF)	1300V

Electrical Characteristics(V⁺=5V, T_A = 25°C, unless otherwise stated)

Parameter	Conditions	LM193A			Units
		Min	Typ	Max	
Input Offset Voltage	(Note 9)		1.0	2.0	mV
Input Bias Current	I _{IN} (+) or I _{IN} (-) with Output In Linear Range, V _{CM} = 0V (Note 5)		25	100	nA
Input Offset Current	I _{IN} (+) - I _{IN} (-) V _{CM} = 0V		3.0	25	nA
Input Common Mode Voltage Range	V ₊ = 30V (Note 6)	0		V ₊ - 1.5	V
Supply Current	R _L = ∞	V ⁺ = 5V	0.4	1	mA
		V ⁺ = 36V	1	2.5	mA
Voltage Gain	R _L ≥ 15 kΩ, V ⁺ = 15V V _O = 1V to 11V	50	200		V/mV
Large Signal Response Time	V _{IN} = TTL Logic Swing, V _{REF} = 1.4V V _{RL} = 5V, R _L = 5.1 kΩ		300		ns
Response Time	V _{RL} = 5V, R _L = 5.1 kΩ (Note 7)		1.3		μs
Output Sink Current	V _{IN} (-) = 1V, V _{IN} (+) = 0, V _O ≈ 1.5V	6.0	16		mA
Saturation Voltage	V _{IN} (-) = 1V, V _{IN} (+) = 0, I _{SINK} ≤ 4 mA		250	400	mV
Output Leakage Current	V _{IN} (-) = 0, V _{IN} (+) = 1V, V _O = 5V		0.1		nA

Electrical Characteristics(V⁺=5V, T_A = 25°C, unless otherwise stated)

Parameter	Conditions	LM193			LM293, LM393			LM2903			Units
		Min	Typ	Max	Min	Typ	Max	Min	Typ	Max	
Input Offset Voltage	(Note 9)		1.0	5.0		1.0	5.0		2.0	7.0	mV
Input Bias Current	I _{IN} (+) or I _{IN} (-) with Output In Linear Range, V _{CM} = 0V (Note 5)		25	100		25	250		25	250	nA
Input Offset Current	I _{IN} (+) - I _{IN} (-) V _{CM} = 0V		3.0	25		5.0	50		5.0	50	nA
Input Common Mode Voltage Range	V ₊ = 30V (Note 6)	0		V ₊ - 1.5	0		V ₊ - 1.5	0		V ₊ - 1.5	V

Electrical Characteristics (Continued) $(V^+=5V, T_A = 25^\circ C, \text{ unless otherwise stated})$

Parameter	Conditions		LM193		LM293, LM393		LM2903		Units
			Min	Typ	Max	Min	Typ	Max	
Supply Current	$R_L = \infty$	$V^+ = 5V$	0.4	1	0.4	1	0.4	1.0	mA
		$V^+ = 36V$	1	2.5	1	2.5	1	2.5	mA
Voltage Gain	$R_L \geq 15 \text{ k}\Omega$	$V^+ = 15V$ $V_O = 1V \text{ to } 11V$	50	200	50	200	25	100	V/mV
Large Signal Response Time	$V_{IN} = \text{TTL Logic Swing}, V_{REF} = 1.4V$ $V_{RL} = 5V, R_L = 5.1 \text{ k}\Omega$		300		300		300		ns
Response Time	$V_{RL} = 5V, R_L = 5.1 \text{ k}\Omega$ (Note 7)		1.3		1.3		1.5		μs
Output Sink Current	$V_{IN(-)} = 1V, V_{IN(+)} = 0, V_O \leq 1.5V$		6.0	16	6.0	16	6.0	16	mA
Saturation Voltage	$V_{IN(-)} = 1V, V_{IN(+)} = 0, I_{SINK} \leq 4 \text{ mA}$		250	400	250	400	250	400	mV
Output Leakage Current	$V_{IN(-)} = 0, V_{IN(+)} = 1V, V_O = 5V$		0.1		0.1		0.1		nA

Electrical Characteristics $(V^+ = 5V)$ (Note 4)

Parameter	Conditions	LM193A			Units
		Min	Typ	Max	
Input Offset Voltage	(Note 9)	4.0			mV
Input Offset Current	$I_{IN(+)} - I_{IN(-)}, V_{CM} = 0V$	100			nA
Input Bias Current	$I_{IN(+)}$ or $I_{IN(-)}$ with Output in Linear Range, $V_{CM} = 0V$ (Note 5)	300			nA
Input Common Mode Voltage Range	$V^+ = 30V$ (Note 6)	0	$V^+ - 2.0$		V
Saturation Voltage	$V_{IN(-)} = 1V, V_{IN(+)} = 0, I_{SINK} \leq 4 \text{ mA}$	700			mV
Output Leakage Current	$V_{IN(-)} = 0, V_{IN(+)} = 1V, V_O = 30V$	1.0			μA
Differential Input Voltage	Keep All V_{IN} 's $\geq 0V$ (or V^- , if Used), (Note 8)	36			V

Electrical Characteristics $(V^+ = 5V)$ (Note 4)

Parameter	Conditions	LM193		LM293, LM393		LM2903		Units
		Min	Typ	Max	Min	Typ	Max	
Input Offset Voltage	(Note 9)	9		9		9	15	mV
Input Offset Current	$I_{IN(+)} - I_{IN(-)}, V_{CM} = 0V$	100		150		50	200	nA
Input Bias Current	$I_{IN(+)}$ or $I_{IN(-)}$ with Output in Linear Range, $V_{CM} = 0V$ (Note 5)	300		400		200	500	nA
Input Common Mode Voltage Range	$V^+ = 30V$ (Note 6)	0	$V^+ - 2.0$		0	$V^+ - 2.0$		V
Saturation Voltage	$V_{IN(-)} = 1V, V_{IN(+)} = 0,$ $I_{SINK} \leq 4 \text{ mA}$	700		700		400	700	mV
Output Leakage Current	$V_{IN(-)} = 0, V_{IN(+)} = 1V, V_O = 30V$	1.0		1.0		1.0		μA
Differential Input Voltage	Keep All V_{IN} 's $\geq 0V$ (or V^- , if Used), (Note 8)	36		36		36		V

Note 1: For operating at high temperatures, the LM393 and LM2903 must be derated based on a $125^\circ C$ maximum junction temperature and a thermal resistance of $170^\circ C/W$ which applies for the device soldered in a printed circuit board, operating in a still air ambient. The LM193/LM193A/LM293 must be derated based on a $150^\circ C$ maximum junction temperature. The low bias dissipation and the "ON-OFF" characteristic of the outputs keeps the chip dissipation very small ($P_D \leq 100 \text{ mW}$), provided the output transistors are allowed to saturate.

Note 2: Short circuits from the output to V^+ can cause excessive heating and eventual destruction. When considering short circuits to ground, the maximum output current is approximately 20 mA independent of the magnitude of V^+ .

Note 3: This input current will only exist when the voltage at any of the input leads is driven negative. It is due to the collector-base junction of the input PNP transistors becoming forward biased and thereby acting as input diode clamps. In addition to this diode action, there is also lateral NPN parasitic transistor action

Electrical Characteristics (Continued)

on the IC chip. This transistor action can cause the output voltages of the comparators to go to the V^+ voltage level (or to ground for a large overdrive) for the time duration that an input is driven negative. This is not destructive and normal output states will re-establish when the input voltage, which was negative, again returns to a value greater than $-0.3V$.

Note 4: These specifications are limited to $-55^{\circ}C \leq T_A \leq +125^{\circ}C$, for the LM193/LM193A. With the LM293 all temperature specifications are limited to $-25^{\circ}C \leq T_A \leq +85^{\circ}C$ and the LM393 temperature specifications are limited to $0^{\circ}C \leq T_A \leq +70^{\circ}C$. The LM2903 is limited to $-40^{\circ}C \leq T_A \leq +85^{\circ}C$.

Note 5: The direction of the input current is out of the IC due to the PNP input stage. This current is essentially constant, independent of the state of the output so no loading change exists on the reference or input lines.

Note 6: The input common-mode voltage or either input signal voltage should not be allowed to go negative by more than $0.3V$. The upper end of the common-mode voltage range is $V^+ - 1.5V$ at $25^{\circ}C$, but either or both inputs can go to $36V$ without damage, independent of the magnitude of V^+ .

Note 7: The response time specified is for a 100 mV input step with 5 mV overdrive. For larger overdrive signals 300 ns can be obtained, see typical performance characteristics section.

Note 8: Positive excursions of input voltage may exceed the power supply level. As long as the other voltage remains within the common-mode range, the comparator will provide a proper output state. The low input voltage state must not be less than $-0.3V$ (or $0.3V$ below the magnitude of the negative power supply, if used).

Note 9: At output switch point, $V_O = 1.4V$, $R_S = 0\Omega$ with V^+ from $5V$ to $30V$; and over the full input common-mode range ($0V$ to $V^+ - 1.5V$), at $25^{\circ}C$.

Note 10: Refer to RETS193AX for LM193AH military specifications and to RETS193X for LM193H military specifications.

Ordering Information

Package	Temperature Range	Part Number	NSC Drawing
8-Pin Metal Can	$-55^{\circ}C$ to $125^{\circ}C$	LM193H*	H08C
		LM193H/883	
		LM193H-MLS	
		LM193AH-MLS	
		LM193AH-QMLV**	
		LM193AH	
	LM193AH/883		
	$-25^{\circ}C$ to $85^{\circ}C$	LM293H	
	$0^{\circ}C$ to $70^{\circ}C$	LM393H	
8-Pin Ceramic DIP	$-55^{\circ}C$ to $125^{\circ}C$	LM193J/883*	J08A
		LM193AJ/883	
		LM193AJ-QMLV**	
		LM193AJ-MLS	
8-Pin Molded DIP	$0^{\circ}C$ to $70^{\circ}C$	LM393N	N08E
	$-40^{\circ}C$ to $85^{\circ}C$	LM2903N	
8-Pin SOIC	$0^{\circ}C$ to $70^{\circ}C$	LM393M	M08A
		LM393MX	
	$-40^{\circ}C$ to $85^{\circ}C$	LM2903M	
		LM2903MX	
8-Bump (12 mils) micro SMD	$0^{\circ}C$ to $70^{\circ}C$	LM393TL	TLA08AAA
		LM393TLX	
	$-40^{\circ}C$ to $85^{\circ}C$	LM2903ITL	
		LM2903ITLX	

Note: * Also available per LM38510/11202

Note: ** See STD Mil DWG 5962-94526

Physical Dimensions inches (millimeters) unless otherwise noted (Continued)

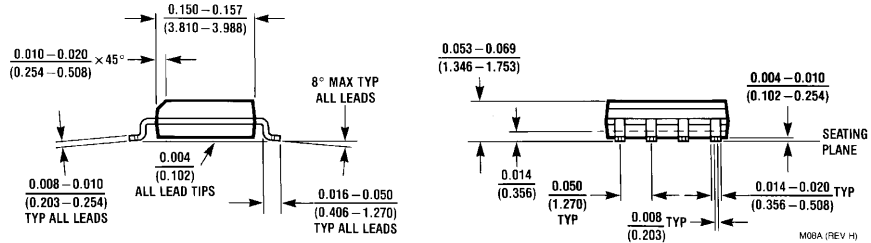
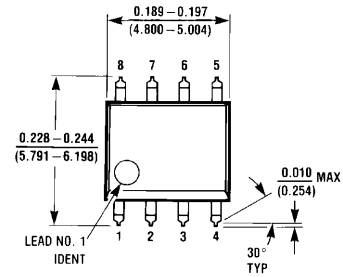

**SOIC Package
NS Package Number M08A**

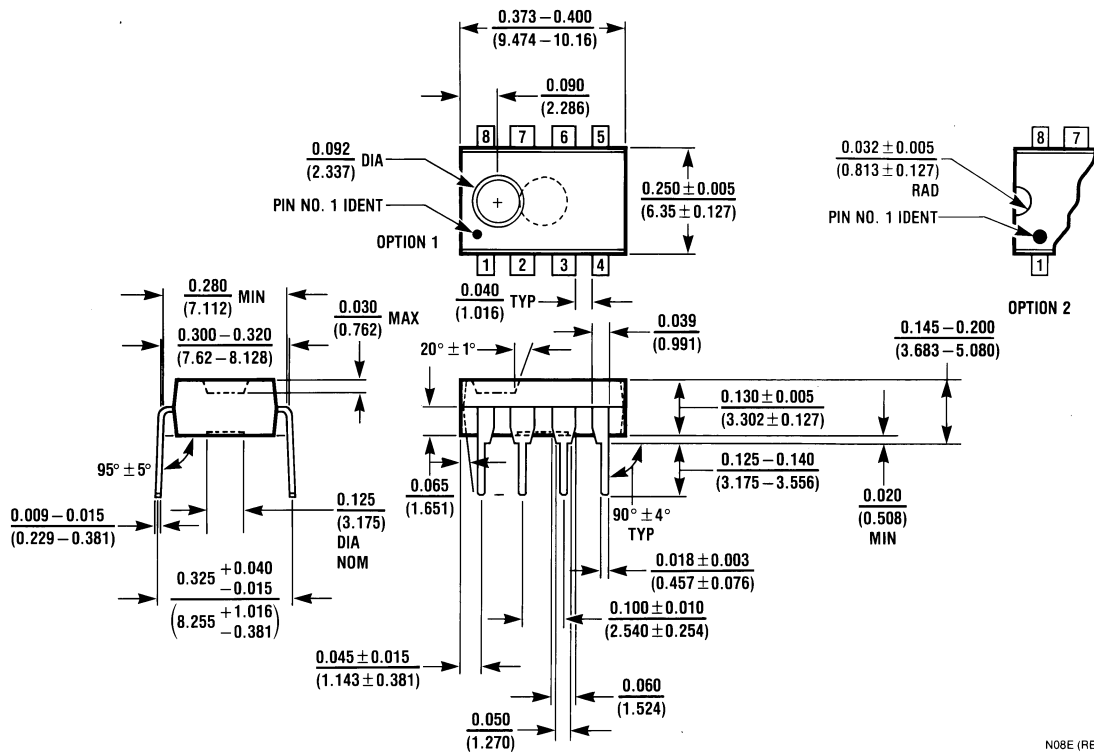

**Molded Dual-In-Line Package (N)
NS Package N08E**