

Emitters

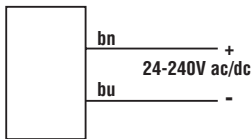

All Models Except Emitters

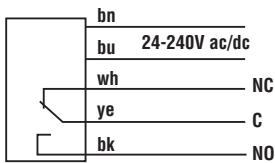

Sensing Mode		Range	LED	Model*
	Opposed Emitter	3 m (10')	Infrared 880 nm	SMU31E
	Opposed Receiver			SMU31R
	Opposed Emitter - Long Range	30 m (100')		SMU31EL
	Opposed Receiver - Long Range			SMU31RL
	Non-Polarized Retroreflective	5 m (15')	Visible Red 650 nm	SMU315LV
	Polarized Retroreflective	10 mm to 3 m (0.4" to 10')		SMU315LP
	Diffuse	380 mm (15")	Infrared 880 nm	SMU315D
	Divergent Diffuse	130 mm (5")		SMU315W
	Convergent	16 mm (0.65") 1.3 mm (0.05") †	Visible Red 650 nm	SMU315CV
		43 mm (1.7") 3 mm (0.07") †		SMU315CV2
	Glass Fiber Optic	Range varies depending on sensing mode and fiber optics used	Infrared 880 nm	SMU315F
				Visible Red 650 nm
			Plastic Fiber Optic	

* Standard 2 m (6.5') cable models are listed. For **9 m (30') cable**, add suffix "W/30" to the model number (e.g., SMU31E W/30).

† Spot size (diameter of sensing beam) at focus.

NOTES:

- Output Type for all models (except emitters) is SPDT Electromechanical Relay.
- Install transient suppressor (MOV) across contacts switching inductive loads.
- Connection of dc power is without regard to polarity.
- Maximum switching current is 3 amps (see specifications).

Dimensions

Models with suffix E, EL, R, RL, LV, LP, D, CV, and CV2

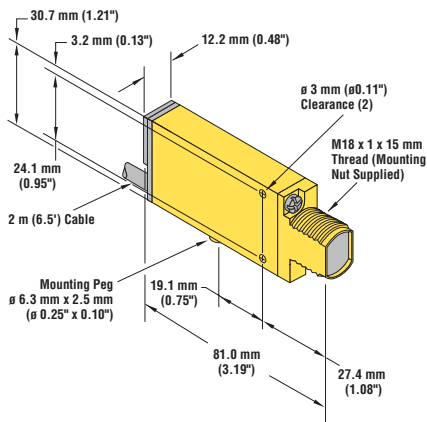

Model SMU315W

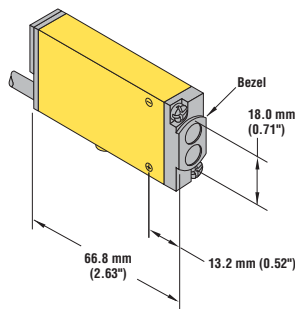

Model SMU315FP

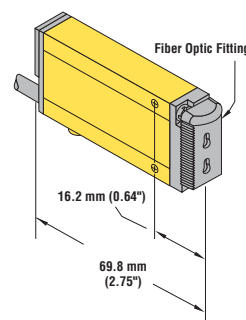

Models with suffix F and FV

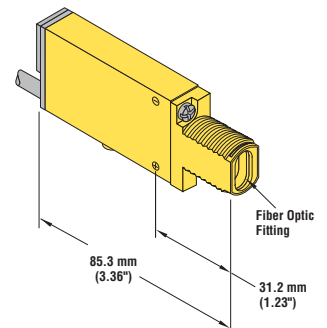

Specifications

Supply Voltage and Current

24 to 240V ac, 50/60 Hz or
24 to 240V dc (1.5 watts or 2.5 VA maximum)

Supply Protection Circuitry

Protected against transient voltages. DC hookup is without regard to polarity.

Output Configuration

SPDT (Single-Pole, Double Throw) (form C) electromechanical relay, ON/OFF output.

Output Rating

Maximum switching power (resistive load): 90W, 250VA
Maximum switching voltage (resistive load): 250V ac or 30V dc
Maximum switching current (resistive load): 3A
Minimum voltage and current: 5V dc, 10 mA
Mechanical life: 20,000,000 operations
Electrical life at full resistive load: 100,000 operations

Output Protection Circuitry

Protected against false pulse ON power-up.

Output Response Time

Closure time: 20 milliseconds max.
Release time: 20 milliseconds max.
Maximum switching speed: 25 operations per second

Repeatability

All sensing modes: 1millisecond

Adjustments

Light/Dark Operate select switch
15-turn slotted brass screw Gain (sensitivity) adjustment potentiometer
Located on rear panel, protected by a gasketed, clear acrylic cover (see above)

Indicators

Patented Alignment Indicator Device system (AID™) lights a rear-panel-mounted LED indicator whenever the sensor sees a "light" condition. Its pulse rate is proportional to the light signal strength (the stronger the signal, the faster the pulse rate).

Construction

Reinforced thermoplastic polyester housing, totally encapsulated, o-ring seal, acrylic lenses, and stainless steel screws.

Environmental Rating

Meets NEMA standards 1, 2, 3, 3S, 4, 4X, 63, 12, and 13; IEC IP67.

Connections

PVC-jacketed 5-conductor (2-conductor for emitters) 2 m (6.5') or 9 m (30') unterminated cable.

Operating Conditions

Temperature: -20° to +55°C (-4° to +131°F)
Maximum relative humidity: 90% at 50°C (non-condensing)

Application Note

Install transient suppressor (MOV) across contacts switching inductive loads.