

Current refinements (click  to remove)

[Search Tips](#) 
 [Region](#) **USA**  [Product Family](#) **Butt Splice, Non-Insulated**  [Text Search:](#) **'BS18-C'**
**Your search criteria matched only one product, shown below.**

- Designed to splice two solid or stranded wires together to repair or lengthen wires
- Butted configuration provides low profile for limited space applications
- Brazed seam protects terminal barrel from splitting during the crimp process
- Internal wire stop assures proper length of insertion into terminal barrel
- Maximum recommended operating temperature 302°F (150°C)
- Non-insulated barrel can be used to provide an economical termination when insulation is not required

‡UL and CSA approved tooling/product combinations.

Part Number:	BS18-C
RoHS Compliancy Status:	Compliant
Part Description:	Butt Splice, non-insulated, 22 – 18 AWG wire range.
Product Type:	Splices
CSA Certified:	Yes
UL Listed:	Yes
Length (In.):	.62
Angle:	straight
Tool:	CT-100A, CT-200, CT-600-A, CT-1570, CT-2500
Wire Range:	22 – 18 AWG
Wire Range (mm <sup>2</sup> ):	0.5 – 1.0
Min. Order UOM:	PC
Min. Order Qty.:	100
BOM Qty. (# of Pkgs.)	
Add to My Catalog	

[View Content Details](#)

Evaluate

Design a Solution

Install &amp; Maintain

Part Drawings:

 [Butt Splice - Non-Insulated pdf](#)

Design a Solution

**Part Drawings:**
 [Butt Splice - Non-Insulated pdf](#)

THIS COPY IS PROVIDED ON A RESTRICTED BASIS AND IS NOT TO BE USED IN ANY WAY DETRIMENTAL TO THE INTERESTS OF PANDUIT CORP.

PANDUIT PART NUMBER		WIRE SIZE AWG	DIMENSIONS in.		
PREFIX	PK.		A ±.02	B DIA. ±.01	C ±.01
BS18	-C -M	22-18	.62 (15.7)	.14 (3.6)	.032 (0.81)
BS14	-C -M	16-14	.62 (15.7)	.16 (4.1)	.032 (0.81)
BS10	-L -D	12-10	.63 (16.0)	.22 (5.6)	.040 (1.02)

NOTES:

- UL LISTED AND CSA CERTIFIED FOR:
  - SOLID OR STRANDED COPPER WIRE
  - 302° F (150° C) MAX. TEMP. RATING
- MATERIAL:
  - STAMPING - COPPER, TIN PLATED
- PACKAGE QTY: STD. PKG. -L=50 BULK PKG. -D=500  
-C=100 -M=1000
- DIMENSIONS IN BRACKETS ARE IN MILLIMETERS
- INSTALLATION TOOLS:
  - UL LISTED AND CSA CERTIFIED: CT-100, CT-200, CT-570, CT-1570
  - PANDUIT APPROVED: CT-160, CT-260
- WIRE STRIP LENGTH:  $9/32 \text{ }^{+1/32}_{-0} \text{ (7.1 } ^{+8}_{-0} \text{)}$

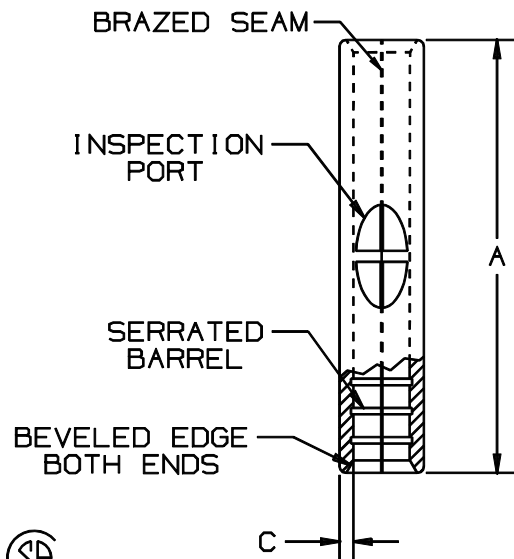
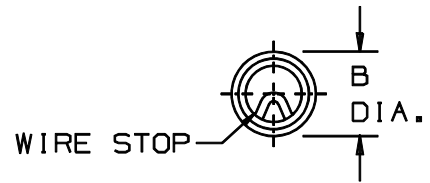

LISTED  
587H  
E52164



CERTIFIED  
LR31212

A41338\_05

05	2/01	KMD		DRAWING NUMBER WAS 41338A				<b>PANDUIT</b> CORP.	TINLEY PARK, ILLINOIS		
04	8/98	DL		UPDATED BS10 A DIM. WAS .72 UPDATED NOTES & WIRE STOP CONFIGURATION	07119						
03	10/94	TH	RLS	UPDATED NOTES AND DIMENSIONS	02547	LA	TKE	NON-INSULATED BUTT SPLICE			
2	9-88	DW		REDRAWN WITH REVISIONS							
REV	DATE	BY	CHK	DESCRIPTION	ECN #	CUST	PM	DRAWN BY DAW	CHK'D	SCALE NONE	DRAWING NO. A41338