

Resettable Thermal Circuit Breaker, Single Pole, 4–16 A

NEW

T9-311: Threaded neck



T9-311 with cover TZZ31



T9-611: Snap-in from front side



T9-711: Snap-in from back side

**Description**

- Thermal circuit breaker
- Supplementary protector for general industrial use
- Cycling trip-free release
- Reset type
- Single pole
- Mounting style: T9-311: Threaded neck
T9-611: Snap-in front side
T9-711: Snap-in rear side

Applications

- Power supplies
- UPS
- Power tools
- Household appliances
- Industrial appliances
- Medical diagnostic appliances
- HVAC

Standards

- IEC 60934
- UL 1077
- CSA C22.2 235
- GB 17701

Technical Data

Rated voltage	(see approvals)	AC 240 V, 50/60 Hz DC 48/32 V
Rated current		4–16 A
Conditional short circuit capacity	IEC: Inc, PC1, AC 240 V CSA: SC, AC 240 V / DC 48/32 V	2 kA 2 kA, C1
Overload rating	According to CSA C22.2 235	OLO 240 VAC OLO 48 VDC and 32 VDC
Degree of protection	Accessible range Termination range	IP 40 IP 00
Endurance minimum	IEC: 200% I _n , cos phi 0.6	min. 50 cycles
Endurance typical	4–8 A: 150% I _n , cos phi 0.9 10–16 A: 150% I _n , cos phi 0.9	2500 cycles 6000 cycles
Dielectric strength		AC 1500 V
Insulation resistance	DC 500 V	> 100 MΩ
Ambient temperature	5–16 A 4 A	-5 °C to 60 °C -5 °C to 50 °C
Type of actuation	Reset Type (manual)	R
Type of tripping		Cycling trip-free
Weight		9 g

Typical internal resistance

Rated current	Internal resistance (mΩ)	Rated current	Internal resistance (mΩ)
4 A	21.6	10 A	7.3
5 A	23.6	12 A	7.0
6 A	16.3	14 A	4.8
7 A	15.3	15 A	4.3
8 A	12.9	16 A	3.9

TRIPPING CHARACTERISTICS

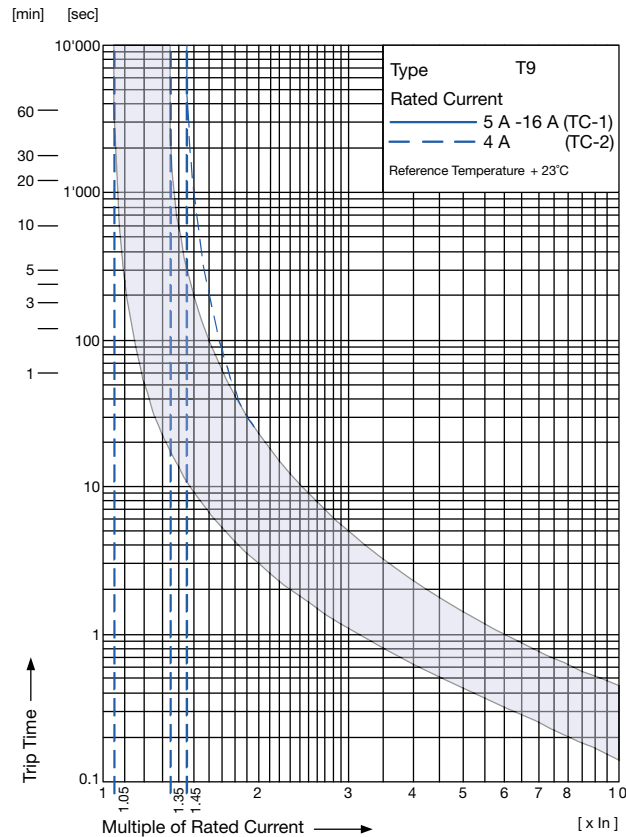

Effect of ambient temperature

The units are calibrated for an ambient temperature of +23°C. To determine the rated current for a lower or higher ambient temperature, use a correction factor from the table below:

Ambient temperature (°C)	Correction factor
-5	0,85
+10	0,95
+23	1,00
+40	1,08
+60	1,21

Example

Rated current at +23°C	10,0 A
Ambient temperature	+60°C
Correction factor	1,21
Chosen rated current at +60°C ambient temperature	$10,0 \text{ A} \times 1,21 = 12,1 \text{ A}$

APPROVALS

		Rated currents	Rated voltage AC	Rated voltage DC
UL	UL 1077	4-12 A	240 V	48 V
		> 12-16 A	240 V	32 V
UL	CSA C22.2 235	4-12 A	240 V	48 V
		> 12-16 A	240 V	32 V
VDE	IEC 60934	4-12 A	240 V	48 V
		> 12-16 A	240 V	32 V
CQC	GB 17701	4-16 A	240 V	

ORDER CODE

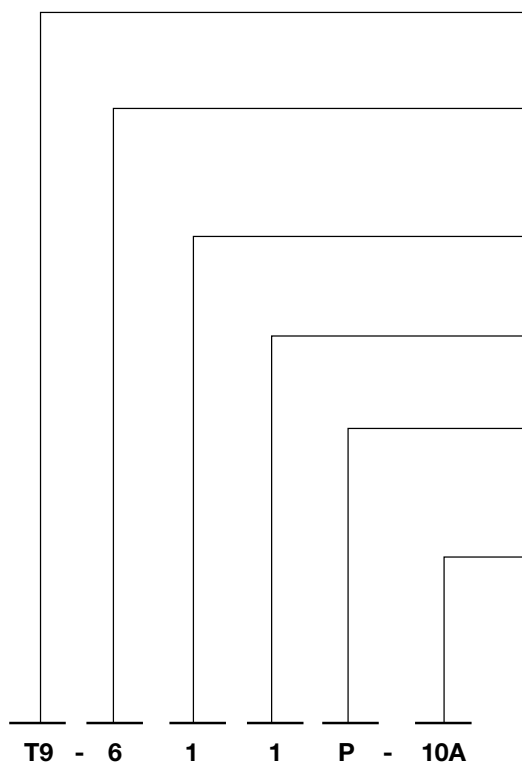
**Basic type**

T9 single pole, thermal overload switch, cycling trip-free

Mounting style

- 3** Threaded neck type (including one hexagonal nut)
- 6** Snap-in type from front side (0.8...2.0 mm)
- 7** Snap-in type from rear side (0.5...3.0 mm)

Actuation type

- 1** Reset Type (R-type)

Terminal type

- 1** 6.3 x 0.8 mm quick connect terminals IEC 61210

Front printing

- C** rated current not marked on front (T9-311 and T9-711)
- P** rated current printed on front (T9-611 only)

Rated current

- | | |
|------------|-------------|
| 4 A | 10 A |
| 5 A | 12 A |
| 6 A | 14 A |
| 7 A | 15 A |
| 8 A | 16 A |

Accessories

Protection cover TZZ31 for IP 65 for type T9-311:



Hexagonal nut TZZ12:

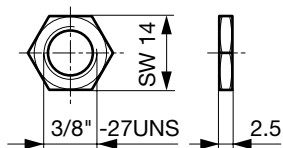

Order number	Type description	
4404.0039	TZZ31	Protection cover for IP 65
4400.0420	TZZ11	Knurled nut nickel-plated
4400.0559	TZZ11-414	Knurled nut black
4400.0425	TZZ12	Additional hexagonal nut nickel-plated

DIMENSIONS

T9-311

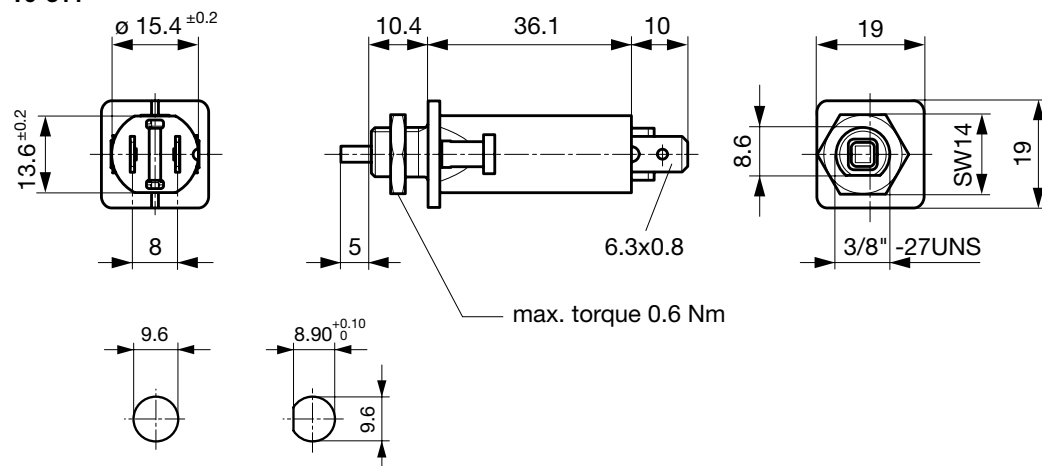

Panel thickness S = 0.8–5.5 mm

T9-611

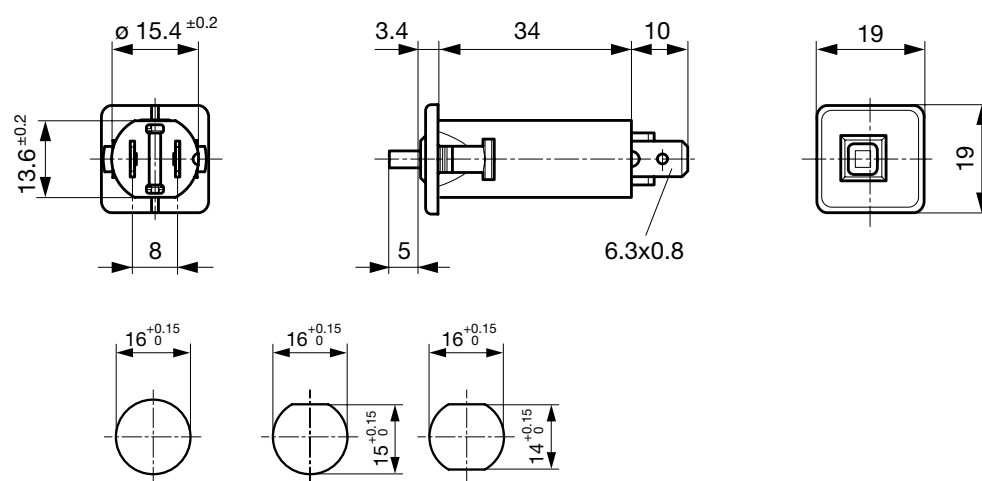

Panel thickness S = 0.8–2.0 mm Recommended panel thickness: 0.8/1.2/1.6/2.0 mm

T9-711

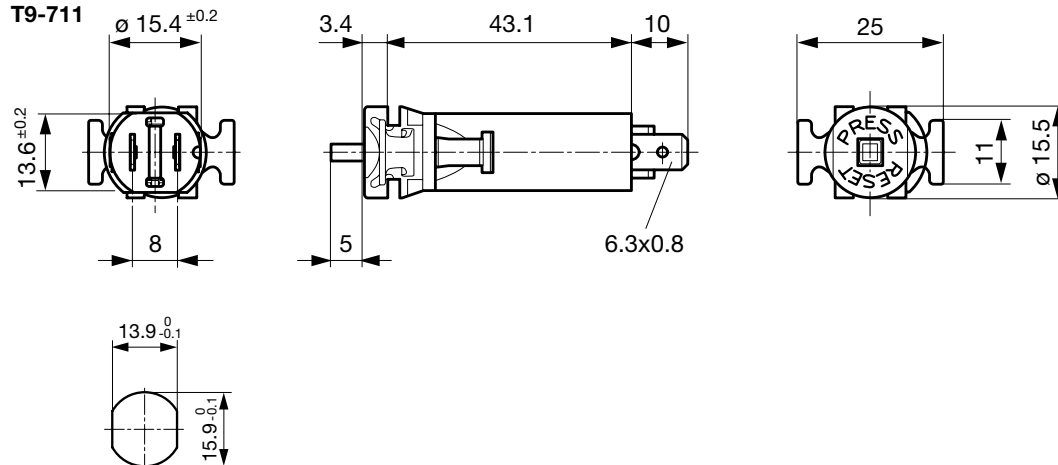

Panel thickness S = 0.5–3.0 mm