

# NPN Silicon Phototransistors

Types OP800SL, OP801SL, OP802SL, OP803SL, OP804SL, OP805SL

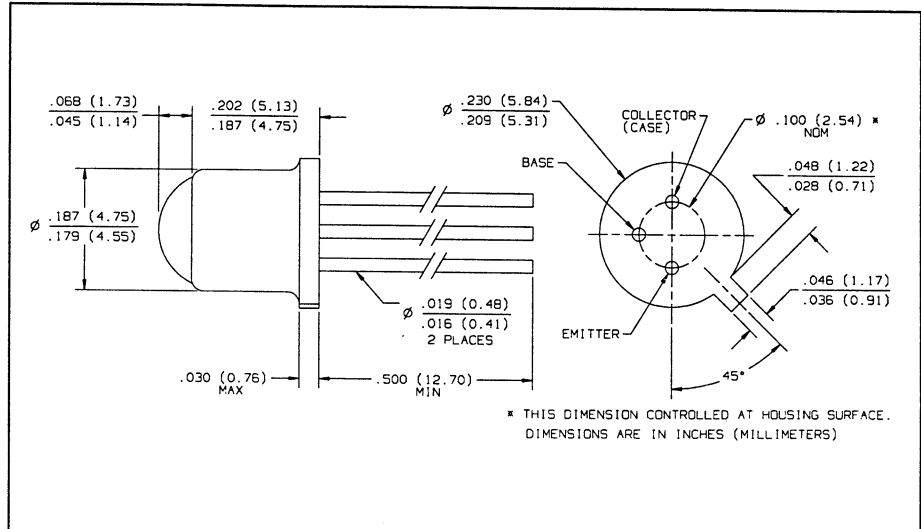
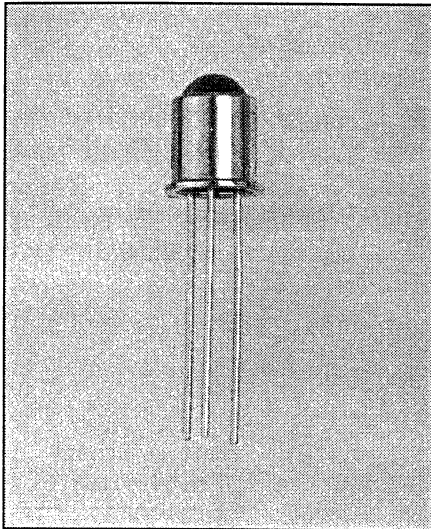

## Features

- Narrow receiving angle
- Variety of sensitivity ranges
- Enhanced temperature range
- TO-18 hermetically sealed package
- Mechanically and spectrally matched to the OP130 and OP231 series of infrared emitting diodes
- TX/TXV processing available

## Description

The OP800SL series device consists of an NPN silicon phototransistor mounted in a hermetically sealed package. The narrow receiving angle provides excellent on-axis coupling. TO-18 packages offer high power dissipation and superior hostile environment operation. The base lead is bonded to enable conventional transistor biasing.

## Replaces

OP800 and K5251 series

## Absolute Maximum Ratings ( $T_A = 25^\circ\text{C}$ unless otherwise noted)

Collector-Base Voltage	30 V
Collector-Emitter Voltage	30 V
Emitter-Base Voltage	5.0 V
Emitter-Collector Voltage	5.0 V
Continuous Collector Current	50 mA
Storage Temperature Range	$-65^\circ\text{C}$ to $+150^\circ\text{C}$
Operating Temperature Range	$-65^\circ\text{C}$ to $+125^\circ\text{C}$
Lead Soldering Temperature [1/16 inch (1.6 mm) from case for 5 sec. with soldering iron]	$260^\circ\text{C}^{(1)}$
Power Dissipation	$250\text{ mW}^{(2)}$

### Notes:

- (1) RMA flux is recommended. Duration can be extended to 10 sec. max. when flow soldering.
- (2) Derate linearly  $2.5\text{ mW}/^\circ\text{C}$  above  $25^\circ\text{C}$
- (3) Junction temperature maintained at  $25^\circ\text{C}$
- (4) Light source is an unfiltered tungsten bulb operating at  $CT = 2870\text{ K}$  or equivalent infrared source.

## Typical Performance Curves

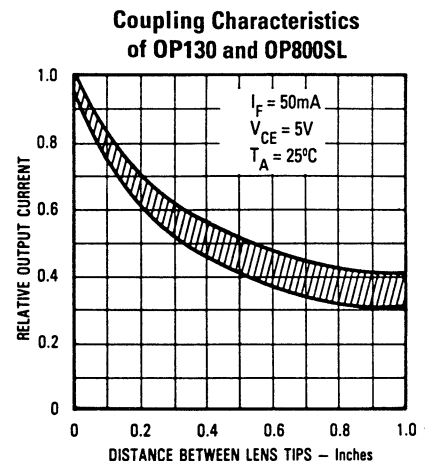
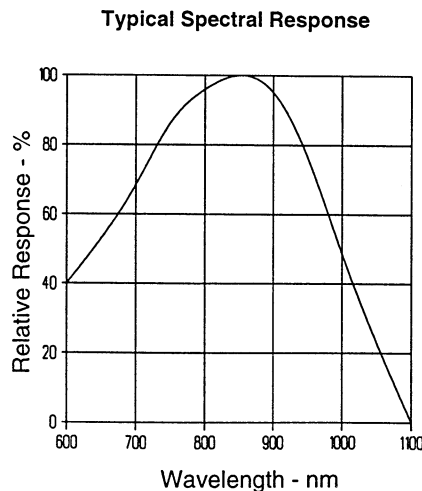

# Types OP800SL thru OP805SL

Electrical Characteristics ( $T_A = 25^\circ\text{C}$  unless otherwise noted)

SYMBOL	PARAMETER	MIN	TYP	MAX	UNITS	TEST CONDITIONS
$I_{C(ON)}$	On-State Collector Current	OP800SL	0.5			$V_{CE} = 5\text{ V}, E_e = 5\text{ mW/cm}^2(3)(4)$
		OP801SL	0.5	3.0		
		OP802SL	2.0	5.0		
		OP803SL	4.0	8.0		
		OP804SL	7.0	22.0		
		OP805SL	15.0			
$I_{CEO}$	Collector Dark Current			100	nA	$V_{CE} = 10\text{ V}, E_e = 0$
$V_{(BR)CEO}$	Collector-Emitter Breakdown Voltage	30			V	$I_C = 100\ \mu\text{A}$
$V_{(BR)CBO}$	Collector-Base Breakdown Voltage	30			V	$I_C = 100\ \mu\text{A}$
$V_{(BR)ECO}$	Emitter-Collector Breakdown Voltage	5.0			V	$I_E = 100\ \mu\text{A}$
$V_{(BR)EBO}$	Emitter-Base Breakdown Voltage	5.0			V	$I_E = 100\ \mu\text{A}$
$V_{CE(SAT)}$	Collector-Emitter Saturation Voltage			0.40	V	$I_C = 0.4\text{ mA}, E_e = 5\text{ mW/cm}^2(4)$
$t_r$	Rise Time		7.0		$\mu\text{s}$	$V_{CC} = 5\text{ V}, I_C = 0.80\text{ mA}, R_L = 100\ \Omega, \text{ See Test Circuit}$
$t_f$	Fall Time		7.0		$\mu\text{s}$	

PHOTOSENSORS

## Typical Performance Curves

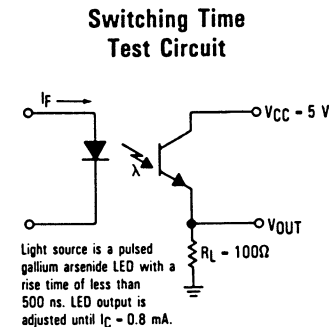
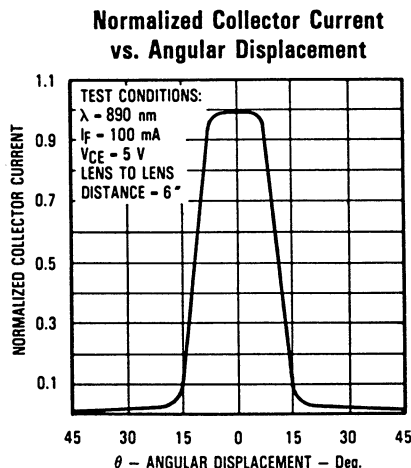
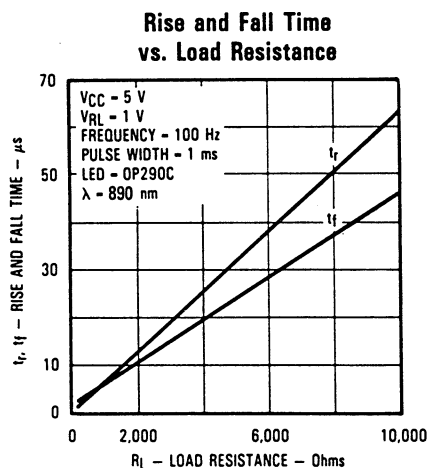
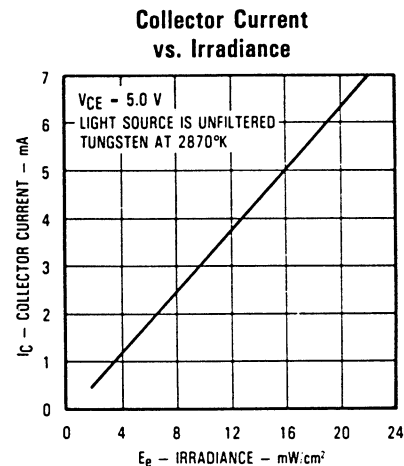
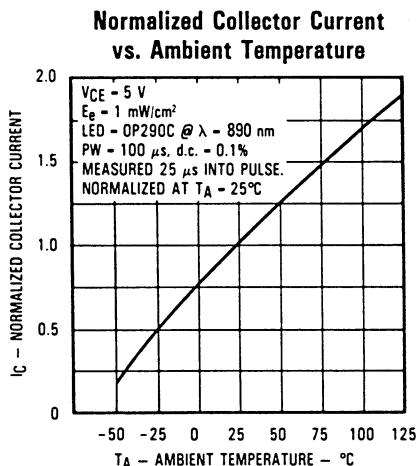
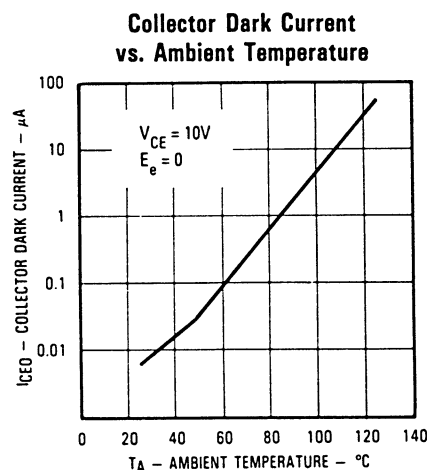

Optek reserves the right to make changes at any time in order to improve design and to supply the best product possible.

Optek Technology, Inc. 1215 W. Crosby Road Carrollton, Texas 75006 (972)323-2200 Fax (972)323-2396