



Connectivity Solutions

Complete or Partial Part #,
Competitor Part # or
Keywords.

Wireless

CATV

Audio & Video

Networking &
Structured Wiring

Military & Aerospace

Test & Measurement

Home

Member Access

Products

Connectors

Microwave Components

CATV Components

Coaxial Cable Assemblies

Structured Cabling & Connectors

Tools & Accessories

Customer Service

Request For Quote

Representatives

Distributors

Literature/Catalog Request

What's New

About Our Brands

Legal Terms

© 2007 All Rights Reserved

Product Detail



Product Line:	Cambridge (Click for customer service)
Part Number:	CPN-8/110
Description:	N Straight Twist-on Plug - 3 Piece, 120 Second Termination
Product Family:	N_CAMBRIDGE
Body Style:	Straight
Color / Finish:	Nickel
Connector A:	Type N
Frequency:	11 GHz
Genders:	Male
Ohm:	50
Product Type:	Cabled
Tool:	24-7712P
RoHS Compliant:	Yes

20070523-1523

Type N

Straight Crimp Type Plug - 120 Second Termination - 3 Piece

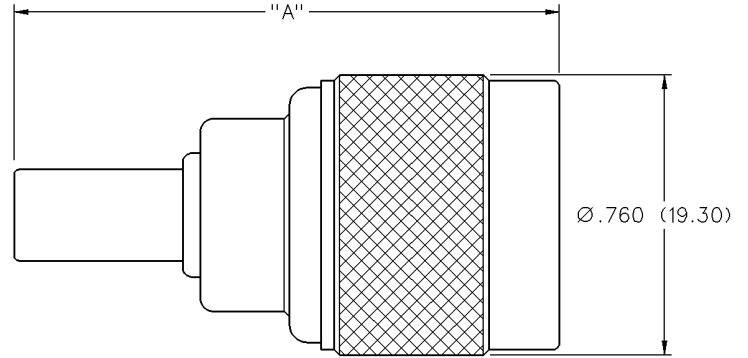

PART NUMBER	CABLE TYPE	"A"	CONTACT I.D.	BODY I.D.	FERRULE I.D.
CPN-8/110	RG-8, 213	1.550 (39.37)	.110 (2.79)	.300 (7.62)	.420 (10.67)

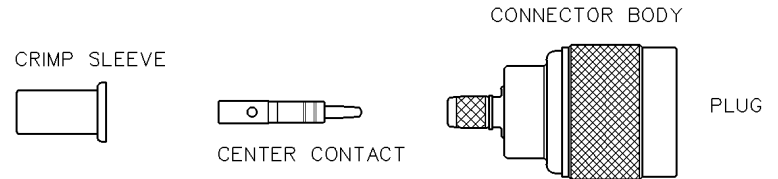
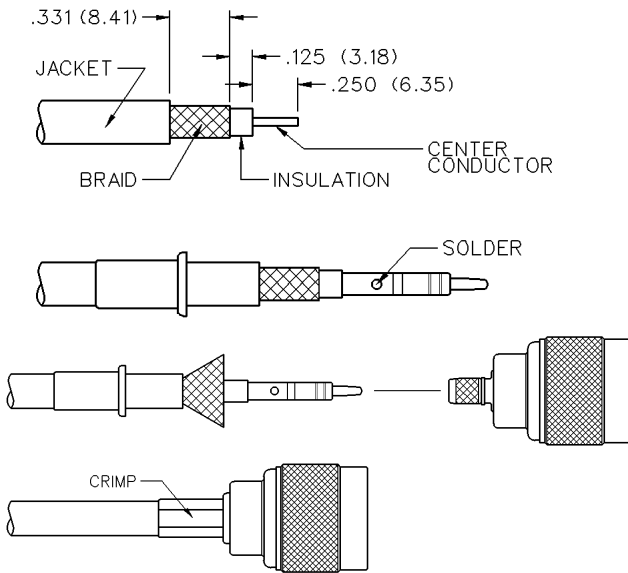

1. Identify connector parts. (3 pieces)
2. Strip cable to dimensions shown. Do not nick the braid or center conductor. Slide the crimp sleeve onto the jacket; narrow end first.
3. Crimp or solder the contact onto the center conductor using the recommended crimp hex or the minimum amount of solder for a good joint.
 Note: Contacts may need to be pre-fit onto the center conductor and soldered through the hole.
4. Flare the braid and slide the connector body over the contact and under the braid. Then seat the body FIRMLY onto the contact; the cable may need to be held in a clamping fixture. Arrange the braid uniformly around the crimp stem, then slide the crimp sleeve forward to the body and crimp the sleeve using the recommended crimp Hex.

CABLE ASSEMBLY NOTES: The contact of the CPN-8/110 connector fits RG 8 cable types with a center conductor diameter up to .110".

Part Number	Cable	Wire Gauge	Wire Decimal	Jacket O.D.	Hex Size	Contact Crimp Hex	Recommended Crimp Tool
CPN-8/110	RG-8, 213	10	.110 (2.80)	.400 (10.16)-.410 (10.44)	.404 (10.26)	.100 (2.54)	24-7712P

N Connectors

Specifications



INCHES (MILLIMETERS)
CUSTOMER DRAWINGS AVAILABLE UPON REQUEST

The N connector employs a large diameter threaded interface for excellent strength and reliability. This commercial quality connector handles high power applications such as antenna feeds for radios and cell sites. Termination options include crimp and clamp styles for rugged service.

Electrical Characteristics

Impedance: 50 Ohm nominal

Frequency range: 0-11 GHz

Working voltage: 500 volts RMS at sea level

Dielectric withstanding voltage: 1500 volts RMS at sea level

Corona level: 375 volts minimum at 70,000 feet

Contact resistance: Outer - 0.2 milliohms maximum
Center - 2.1 milliohms maximum

Insulation resistance: 5000 megohms minimum

Environmental Characteristics

Recommended temperature range: -65°C to +165°C

Moisture Resistance: MIL-STD-202

Mechanical Characteristics

Durability: 500 cycles

Cable retention: 20 lbs., RG-58 C/U cable

Materials

Body and coupling nut: Brass

Contact: Brass, phosphor bronze or beryllium copper

Crimp sleeve: Brass

Insulator: Teflon® or Delrin®

Hardware: Brass

Plating: Body - Nickel

Crimp sleeve - Nickel

Hardware - Nickel

Contact - Gold

* These are typical and may not apply to all connectors.