

3-phase 80 W SMPS with very wide-range input voltage based on the L6565 and ESBT STC04IE170HV

Introduction

The purpose of this application note is to explain the design of an 80 W 3-phase auxiliary power supply for motor drives and welding applications. To reach a high level system in terms of both efficiency and cost, the L6565 PWM controller has been selected as well as the STC04IE170HV as the main switch. The combination of these STMicroelectronics parts provides a highly efficient solution for high DC input voltage, a typical requirement of any three-phase application. The L6565 driver is a variable frequency PWM driver suitable for a design flyback converter working in quasi-resonant mode. It also includes some very useful additional features.

The frequency response study reported in the this document is carried out using MATLAB.

All the design choices are thoroughly discussed to allow the user to adapt the project to specific needs. The input voltage can also be extended up to 1000 VDC as enough margin exists to do so. Finally, the experimental results are analyzed to better understand the benefits offered by the use of ESBT in this application.

The document is associated with demonstration boards STEVAL-ISA019V1 and STEVAL-ISA019V2 (*Figure 1*).

Figure 1. 80 W 3-phase SMPS (working prototype)



Contents

1	Design specifications and L6565 brief description	4
2	Flyback stage design	5
2.1	Transformer design	7
2.1.1	Core size	7
2.1.2	Transformer losses and air gap	7
2.1.3	Wire size	9
3	Base driving circuit design	12
4	Output circuit design	16
5	Startup network design	17
6	Frequency response and loop compensation	18
7	Efficiency, waveforms and experimental results	21
8	PCB layout and list of material	25
9	Bill of material	26
10	Board modifications	28
11	References	32
12	Revision history	33

List of figures

Figure 1.	80 W 3-phase SMPS (working prototype)	1
Figure 2.	Flyback topology basic diagram	4
Figure 3.	Demonstration board schematic	5
Figure 4.	Dynamic magnetization curves	8
Figure 5.	Relative core losses versus frequency	9
Figure 6.	Power transformer Tronic 0600387	11
Figure 7.	Proportional driving schematic and equivalent circuit	12
Figure 8.	Current transformer SL 051 220 21 01	15
Figure 9.	Converter feedback network	19
Figure 10.	Stabilized open loop transfer function $G(s) = G1(s) \cdot G2(s)$ (Bode plots)	20
Figure 11.	Overall efficiency versus output power for two different values of input voltage	21
Figure 12.	Minimum input voltage-maximum load (250 V-80 W) in steady state	22
Figure 13.	Medium input voltage-maximum load (500 V-80 W) in steady state	22
Figure 14.	Maximum input voltage-maximum load (850 V-80 W) in steady state	23
Figure 15.	Very low load condition (750 V-5 W)	23
Figure 16.	Low load condition (750 V-24 W)	23
Figure 17.	High load condition (750 V-80 W)	24
Figure 18.	Proportional base driving circuit relevant waveform	24
Figure 19.	PCB layout (top view)	25
Figure 20.	PCB layout (bottom view)	25
Figure 21.	STEVAL-ISA019V2	28
Figure 22.	STEVAL-ISA019V2 schematic diagram	29
Figure 23.	Power transformer Delta 86H-6017	30
Figure 24.	Silk screen (top side)	31
Figure 25.	Silk screen (bottom side)	31
Figure 26.	Copper tracks	31

1 Design specifications and L6565 brief description

[Table 1](#) lists the converter specification data and the main parameters set for the demonstration board.

Table 1. Converter specification data and fixed parameters

Symbol	Description	Values
V_{inmin}	Rectified minimum input voltage	250
V_{inmax}	Rectified maximum input voltage	850
V_{out}	Output voltage 1	24 V/3.33 A
V_{aux}	Auxiliary output voltage	15 V/0.1 A
P_{out}	Maximum output power	80 W
h	Converter efficiency	> 80%
F	Minimum switching frequency	50 kHz
V_{spike}	Max overvoltage limited by clamping circuit	200 V

[Figure 2](#) shows a simplified schematic diagram of a flyback converter.

The L6565 features a current mode control and is designed for flyback converters working in quasi-resonant mode and ZVS (zero voltage switching) at turn-on, or at least quasi ZVS, which means valley switching during turn-on. This condition allows the designer to reduce the power losses at turn-on as much as possible.

Since the input range is from 250 V up to 850 V, the ZVS is obtained only when $V_{in} = V_{inmin} = V_{fl} = 250$ V.

The L6565 has 8 pins. For a detailed explanation of each pin function, please refer to the L6565 datasheet.

Figure 2. Flyback topology basic diagram

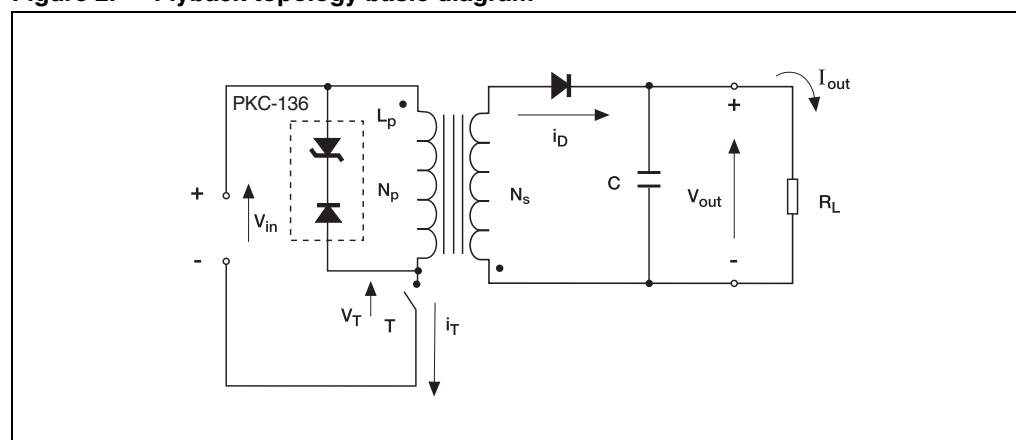

2 Flyback stage design

In *Figure 3* the complete schematic of the 80 W SMPS is shown.

Figure 3. Demonstration board schematic

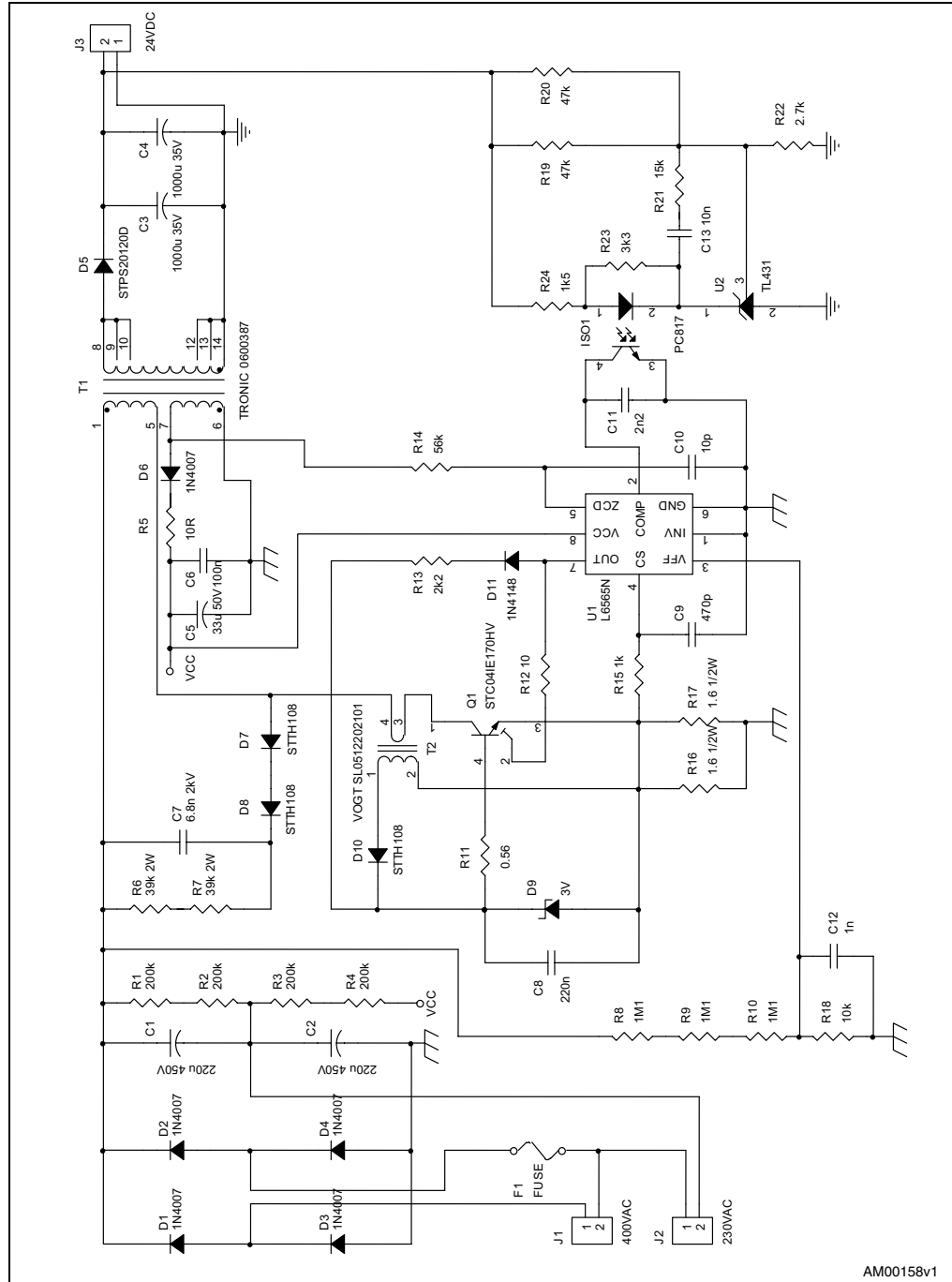

As commonly known, the voltage stress on the device (power switch) is given by:

Equation 1

$$V_{\text{off}} = V_{\text{inmax}} - V_{\text{fl}} - V_{\text{spike}}$$

where V_{fl} = flyback voltage = $(V_{\text{out}} + V_{\text{F, diode}}) \cdot N_{\text{p}} / N_{\text{s}}$ and V_{spike} is the maximum overvoltage allowed by the clamping network. It has been set at 200 V. N_{p} is the number of turns on the primary side, while N_{s} is the number of turns on the main output secondary winding.

Taking into account a 200 V margin, the maximum flyback voltage that can be chosen is:

Equation 2

$$V_{\text{fl}} = BV - V_{\text{inmax}} - V_{\text{spike}} - V_{\text{margin}} = 1700 - 1000 - 200 - 250 = 250\text{V}$$

After calculating the flyback voltage, proceed with the next step in the converter design.

The turn ratio between primary and secondary side is calculated with the following formula:

Equation 3

$$\frac{N_{\text{p}}}{N_{\text{s}}} = \frac{V_{\text{fl}}}{V_{\text{out}} + V_{\text{F, diode}}} = \frac{250}{24 + 1} = 10$$

As a first approximation, since the turn-on of the device occurs immediately after the energy stored on the primary side inductance has been totally transferred to the secondary side:

Equation 4

$$V_{\text{dcmin}} T_{\text{onmax}} = V_{\text{fl}} T_{\text{reset}}$$

and

Equation 5

$$T_{\text{onmax}} + T_{\text{reset}} = T_{\text{S}}$$

where T_{onmax} is the maximum on time, T_{reset} is the time needed to demagnetize the transformer inductance and T_{S} is the switching time.

Combining the two previous equations, T_{onmax} is:

Equation 6

$$T_{\text{onmax}} = \frac{V_{\text{fl}} \cdot T_{\text{S}}}{V_{\text{dcmin}} + V_{\text{fl}}} \cong 10\mu\text{s}$$

The next step is to calculate the peak current. According to the converter specification in [Table 1](#), output power of 80 W and desired efficiency (at least 80%), by using a formula that does not take into account the losses on the power switch, on the input bridge, and on the rectified network, we have:

Equation 7

$$P_{\text{IN}} = 1.25 P_{\text{OUT}} = \frac{\frac{1}{2} \cdot L_{\text{p}} I_{\text{p}}^2}{T_{\text{S}}} = \frac{\frac{1}{2} V_{\text{dcmin}}^2 T_{\text{onmax}}^2}{L_{\text{p}} T_{\text{S}}}$$

Hence:

Equation 8

$$L_P = \frac{V_{dcmin}^2 T_{onmax}^2}{2.5 T_S P_{OUT}} = 1.56 \text{mH}$$

Now we can calculate the peak current on primary.

Equation 9

$$I_P = \frac{V_{dcmin} T_{onmax}}{L_P} = 1.6 \text{A}$$

2.1 Transformer design

2.1.1 Core size

The core size must be chosen according to the power that must be managed, to the primary inductance, and to the saturation current as well. An approximate but efficient formula could be used as a starting point. Eventually, the designer may choose a bigger core and repeat the following steps.

Equation 10

$$A_P = 10^3 \left[\frac{L_P I_{rms(primary)}}{\Delta T^2 \cdot K_U \cdot B_{max}} \right]^{1.316} \quad [\text{cm}^4]$$

where:

- ΔT is the maximum temperature variation with respect to the ambient temperature
- K_U is the utilization factor of the window (say the portion of the window used for winding that generally ranges between 0.4 and 0.7)
- B_{max} is the maximum flux in the core.

From [Equation 10](#), we can deduct that the final best choice is an ETD34.

2.1.2 Transformer losses and air gap

From Faraday's law we can define the minimum primary winding turns to avoid saturation of the core. Looking at the saturation curve of the core, we can safely work up to 200 mT:

Equation 11

$$N_{pmin} = \frac{V_{in, min} \cdot T_{O(N, max)}}{\Delta B \cdot A_e} = \frac{250 \cdot 10 \mu}{0.200 \cdot 97 \mu} = 117$$

Figure 4. Dynamic magnetization curves

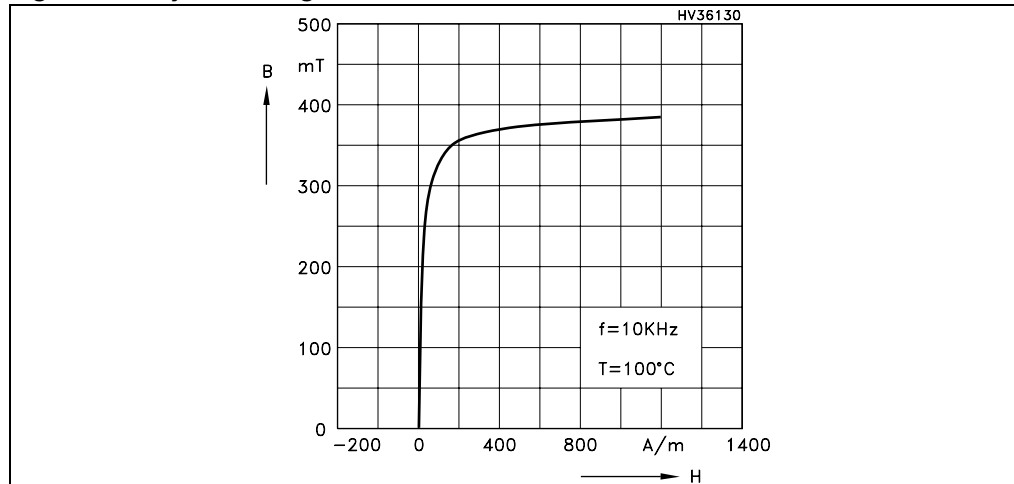

Concerning the gap, from the EPCOS datasheet, we can use the following approximate formula:

Equation 12

$$l_g = \text{gap length} = \left(\frac{A_L}{K_1} \right)^{\frac{1}{K_2}}$$

$K_1 = 153$, $K_2 = -0.713$, while A_L has to be calculated.

Knowing that $L_p = 1.56\text{mH}$ and $N_p = 120$,

Equation 13

$$A_L = \frac{L_p}{N_p^2} = \frac{1.56\text{m}}{120^2} = 108\text{nH}$$

$$\text{Hence: } l_g = \text{gap length} = \left(\frac{108}{153} \right)^{\frac{1}{-0.713}} = 1.63\text{mm}$$

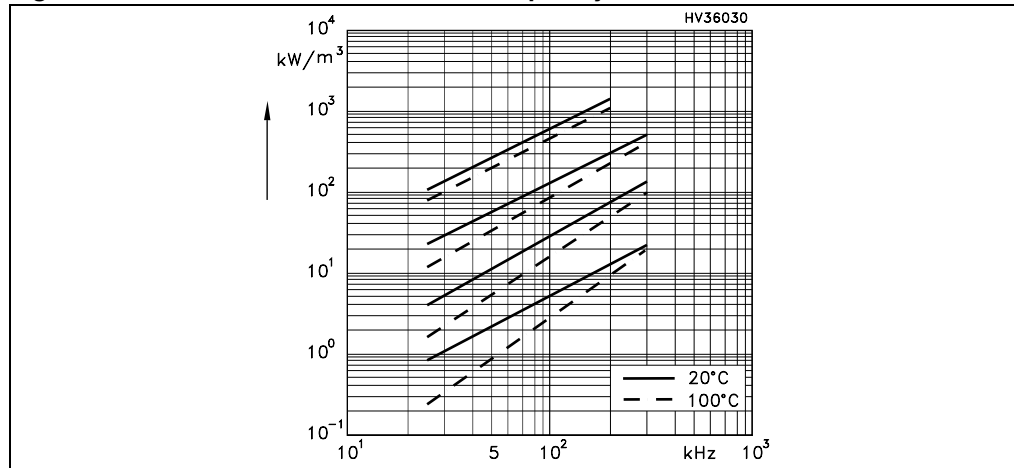
Figure 5. Relative core losses versus frequency

From [Figure 5](#), operating at 50 kHz with 220 mT flux excursion, the power dissipation density is about 300 mW/cm³. Once again, referring to the datasheet, the total volume of ETD 34 is 7.63 cm³, therefore:

Equation 14

$$P_{\text{core}} = 0.3 \cdot 7.6 = 2.29\text{W}$$

Assuming a 95% efficiency for the transformer, only 4 W can be lost on it, of which about 2.3 is lost on the core while the residual 1.7 W is dissipated on the copper. Achieving this efficiency is detailed in the following [Section 2.1.3: Wire size](#).

2.1.3 Wire size

To choose the right wire size we must know the rms current on both the primary and secondary sides. Since $I_{\text{peak, primary}} = 1.6\text{ A}$ and $I_{\text{peak, secondary}} = 16\text{ A}$,

Equation 15

$$I_{\text{rms, primary}} = 0.65\text{A} \quad \text{and} \quad I_{\text{rms, secondary}} = 6.53\text{A}$$

By imposing a 1 W loss on the primary side wire, the maximum series resistance can be calculated as follows:

From Joule's law we can calculate the resistance of both the primary and secondary windings.

Equation 16

$$R_P = \frac{P_{\text{CU, pri}}}{I_{\text{PRMS}}^2} \Rightarrow R_P = 2.36\Omega \quad R_S = \frac{P_{\text{CU, sec}}}{I_{\text{SRMS}}^2} \Rightarrow R_S = 0.016\Omega$$

From that, knowing the copper resistivity at 100 °C ($\rho_{100} = 2.303 \cdot 10^{-6}\ \Omega\text{ cm}$), and the average wind length L_t ($L_t = 5.6\text{ cm}$), we can easily calculate the wire sections (in cm²).

Equation 17

$$A_{\text{PCU}} = \frac{\rho_{100} N_p L_t}{R_P} = 6.54 \cdot 10^{-4} \quad [\text{cm}^2] \Rightarrow d_p = 0.028[\text{cm}]$$

Equation 18

$$A_{SCU} = \frac{\rho_{100} N_S L_t}{R_S} = 0.0096 \quad [\text{cm}^2] \Rightarrow d_s = 0.011[\text{cm}]$$

[Table 2](#) provides the skin effect resistance ratios due to eddy currents for different frequencies.

Table 2. Skin effect AC-DC resistance ratios for square-wave currents

wire no.	Diameter d, mils	25 kHz			50 kHz			100 kHz			200 kHz		
		Skin depth S, mils	d/S	R _{ac} /R _{dc}	Skin depth S, mils	d/S	R _{ac} /R _{dc}	Skin depth S, mils	d/S	R _{ac} /R _{dc}	Skin depth S, mils	d/S	R _{ac} /R _{dc}
12	81.6	17.9	4.56	1.45	12.7	6.43	1.55	8.97	9.10	2.55	6.34	12.87	3.50
14	64.7	17.9	3.61	1.30	12.7	5.08	1.54	8.97	7.21	2.00	6.34	10.21	2.90
16	51.3	17.9	2.87	1.10	12.7	4.04	1.25	8.97	5.72	1.70	6.34	8.09	2.30
18	40.7	17.9	2.27	1.05	12.7	3.20	1.15	8.97	4.54	1.40	6.34	6.42	1.85
20	32.3	17.9	1.80	1.00	12.7	2.54	1.05	8.97	3.60	1.25	6.34	5.09	1.54
22	25.6	17.9	1.43	1.00	12.7	2.02	1.00	8.97	2.85	1.10	6.34	4.04	1.30
24	20.3	17.9	1.13	1.00	12.7	1.60	1.00	8.97	2.26	1.04	6.34	3.20	1.15
26	16.1	17.9	0.90	1.00	12.7	1.27	1.00	8.97	1.79	1.00	6.34	2.54	1.05
28	12.7	17.9	0.71	1.00	12.7	1.00	1.00	8.97	1.42	1.00	6.34	2.00	1.00
30	10.1	17.9	0.56	1.00	12.7	0.80	1.00	8.97	1.13	1.00	6.34	1.59	1.00
32	8.1	17.9	0.45	1.00	12.7	0.84	1.00	8.97	0.90	1.00	6.34	1.28	1.00
34	6.4	17.9	0.36	1.00	12.7	0.50	1.00	8.97	0.71	1.00	6.34	1.01	1.00

Note: To completely avoid the skin effect, the maximum diameter allowed is 20.3 mils, which is equal to 0.5 mm.

For practical considerations, to better optimize the utilization of the transformer window, and comply with [Equation 15](#) to [Equation 18](#) and [Table 2](#), it can be determined that:

Equation 19

$$d_s = 0.05[\text{cm}] \quad 3 \text{ in parallel}$$

The specifications of the transformer provided by Tronic, according to the above calculations, are shown in [Figure 6](#).

Figure 6. Power transformer Tronic 0600387

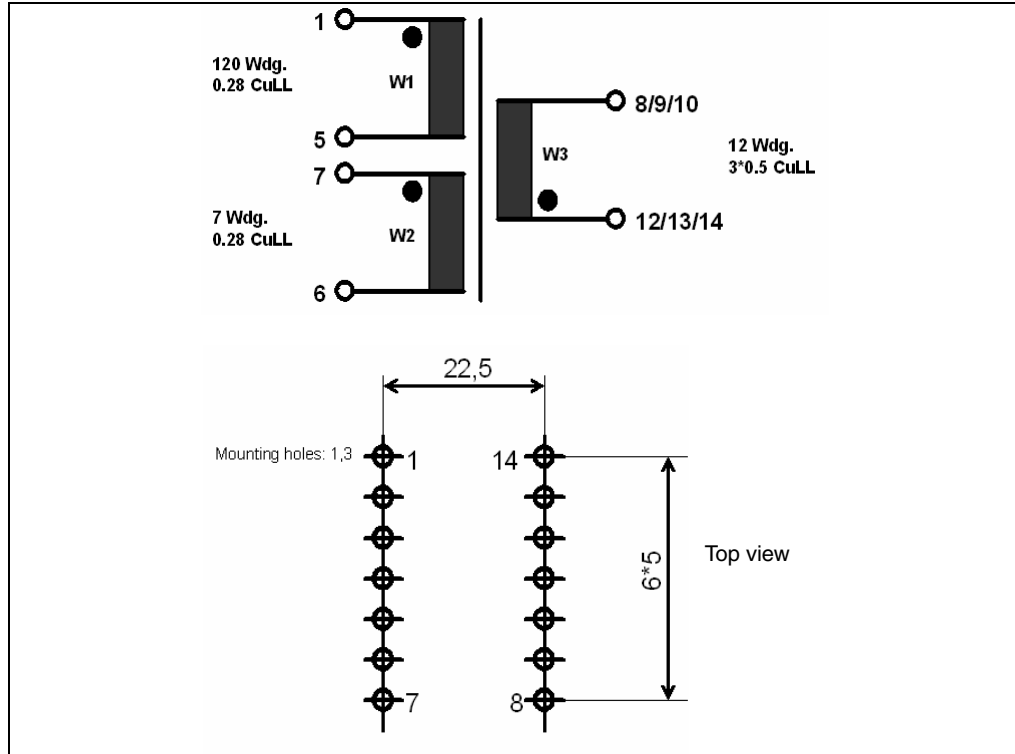

3 Base driving circuit design

In practical applications such as SMPS where the load is variable, the collector current is variable as well. As a consequence it is very important to provide a base current to the device which is related to the collector. In this way it is possible to avoid device over-saturation at low load and to optimize the performance in terms of power dissipation. The best and simplest way to do this is the proportional driving method provided by the current transformer in [Figure 7](#). At the same time, it is very useful to provide a short pulse to the base to make the turn-on as fast as possible and to reduce the dynamic saturation phenomenon. The pulse is achieved by using the capacitor and the Zener in [Figure 7](#).

Figure 7. Proportional driving schematic and equivalent circuit

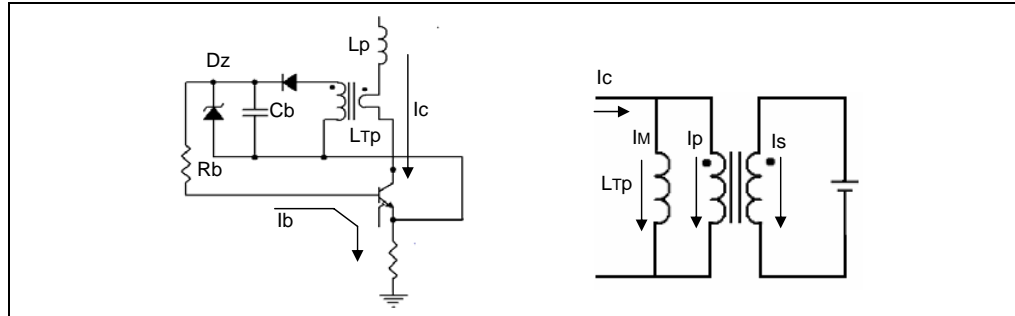

The I_C/I_B ratio is fixed once the current transformer turn ratio has been chosen. From the ESBT STC04DE170 datasheet, and especially looking at the storage time characterization, it is clear that a turn ratio equal to 5 is a good value to ensure the right saturation of the ESBT at $I_C = 2\text{ A}$, so that in the current transformer we can first fix:

Equation 20

$$\frac{N_P}{N_S} = \frac{1}{5}$$

The core magnetic permeability of current transformer must be as high as possible to minimize the magnetization current I_M (which is not transferred to the secondary side but only drives the core into saturation). On the contrary, a too high permeability core may lead the core into saturation even with a very small magnetization current. To avoid saturation, it is necessary to increase the number of primary turns and the size of the core as well. If a core with a very small magnetic permeability is chosen, it is possible to reduce the number of primary turns and the core size. If the permeability is too small, we may not have current on the secondary side because almost all the collector current becomes magnetization current. As a compromise, a ferrite material with a relative permeability in the range 4500-7000 is the best choice.

After selecting the ferrite ring diameter, the minimum primary turns is determined to avoid core saturation from the preliminarily fixed turn ratio N with 0.2. By applying Faraday's law and imposing the maximum flux B_{\max} equal to $B_{\text{sat}}/2$:

Equation 21

$$V_1 = N_{TP} \cdot \frac{d\phi}{dt} \cong N_{TP} \cdot A_e \cdot \frac{\Delta B}{\Delta T} \Rightarrow N_{TP} = 2 \cdot \frac{V_1 \cdot T_{\text{onmax}}}{A_e \cdot B_{\text{sat}}}$$

where B_{sat} is the saturation flux of the core which depends on the magnetic permeability.

During the conduction time, the junction base-emitter of the ESBT can be seen as a forward-biased diode. To complete the secondary side load loop, the voltage drop on both diode D and resistor RB must be added in series with the base of the ESBT. The equivalent secondary side voltage source is given by:

Equation 22

$$V_S = V_{BEon} - V_D - V_{RB} \cong 2.5V$$

Since the magnetization inductance cannot be neglected, only I_P a fraction of the total collector current, is transferred to the secondary. As a result, the magnetization current has to be first as low as possible. Meanwhile, the value of the magnetization inductance must be taken into account for the proper calculation of transformer primary turns and turns ratio. The magnetization voltage drop, that is, the voltage at the primary of the current transformer, can now be easily calculated:

Equation 23

$$V_1 = V_S \cdot \frac{N_{1T}}{N_{2T}} = 2.5 \cdot \frac{1}{5} = 0.5(V)$$

The magnetization current will be:

Equation 24

$$I_{Mmax} = \frac{V_1 T_{ONmax}}{L_{TP}}$$

The number of primary turns should be increased if I_{Mmax} is relatively high. The core must have a window area large enough to hold all primary and secondary windings. Otherwise it is necessary to choose a bigger core size. Once both core material and size are fixed, the turn ratio must be adjusted to get the desired I_C/I_B ratio according to [Equation 25](#) below:

Equation 25

$$N_{eff} = \frac{I_P}{I_B} = \frac{I_{Cmax} - I_{Mmax}}{\frac{I_C}{5}}$$

where I_{Mmax} is the maximum magnetization current.

The insulation between primary and secondary should be considered since the voltage on the primary side during the off time can surpass 1500 V.

The next step is to select the Zener diode, the capacitor C_b , and the resistor R_b . The turn-on performance of the ESBT is related to the initial base peak current and its duration t_{peak} , which is given approximately by [Equation 26](#):

Equation 26

$$t_{peak} = 3R_b C_b$$

A suitable value for R_b is 0.56 Ω . It can eliminate the ringing on the base current after the peak, and at the same time, it generates negligible power dissipation.

The value t_{peak} can be determined once the minimum ON time is set based on the operating frequency. Bear in mind that in practical applications, it should never be lower than 200 ns. The value of C_b can be counted since the values of t_{peak} and R_b are known.

I_{peak} must be limited to avoid extra saturation of the device. The Zener diode D_z controls this and clamps the voltage across the small capacitor C_b . The Zener must be chosen according to the following empirical formulas and inside the range of $V_{Z\text{min}}$ and $V_{Z\text{max}}$:

Equation 27

$$V_{Z\text{max}} = 2(I_{\text{peak}}R_b + 1) \quad V_{Z\text{min}} = 2(I_{\text{peak}}R_b)$$

The base peak current is higher with higher clamp voltage (D_z) or smaller capacitance (C_b), which in turn will lead to shorter duration of the peak time.

The higher and longer the base peak current is, the lower the power dissipation during turn-on. The designer must limit the I_b peak both in terms of amplitude and time duration. Otherwise, at low load a very high saturation level may result. If the device is oversaturated, the storage time is too long with higher power dissipation during turn-off. Moreover, a long storage time can also lead to output oscillation, especially at high input voltage. To overcome these problems, it is recommended to set the peak duration to 1/3 the minimum duty cycle.

Following all the formulas mentioned in this section applied to the present work gives:

Equation 28

$$N_{\text{TP}} = 2 \cdot \frac{V_1 \cdot T_{\text{onmax}}}{A_e \cdot B_{\text{sat}}} \approx 2$$

where A_e is the magnetic area, considering a ring core with 12.5 mm diameter, and the saturation field B_{sat} is 400 mT.

From the first approximated assumption NS should be 10. From bench verification it is very simple to verify that the turn ratio to get the best trade-off between conduction and turn-off losses is 6.

Of course, this verification and final decision has been taken after setting all the other components in the driving network and exactly:

Equation 29

$$t_{\text{peak}} = 3R_bC_c = 400\text{ns} = C_b = 238\text{nF} = C_b = 220\text{nF} \text{ (closest commercial value)}$$

Finally, the Zener has been set to 3 V. [Figure 8](#) shows the current transformer specifications:

Figure 8. Current transformer SL 051 220 21 01

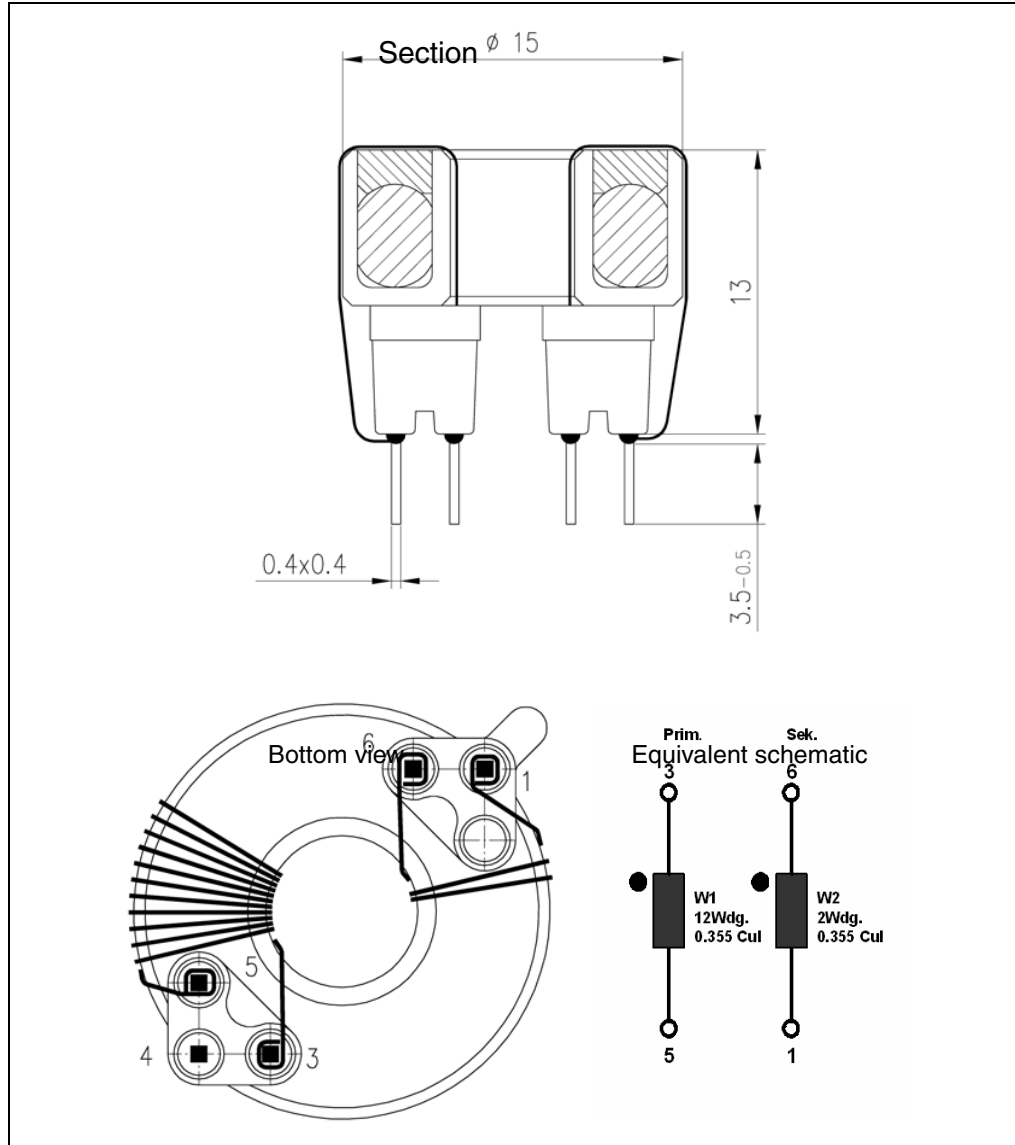

4 Output circuit design

To choose the output capacitor, the series resistance of the electrolytic capacitor must be defined.

It is well known that the main cause of the output ripple is the series resistance of the electrolytic capacitor, known as ESR, while the capacitive ripple is absolutely negligible.

Therefore, with a known secondary side peak current of 16 A and imposing a resistive ripple equal to 2% (0.48 V), we have:

Equation 30

$$\text{ESR} < \frac{V_{\text{ripple}}}{I_{\text{SP}}} = \frac{0.48}{16} = 0.03\Omega$$

Using very low ESR output capacitances, from the catalogue we get the equation $\text{ESR} \cdot C = 32e^{-6}\text{s}$ from which:

Equation 31

$$C_{\text{out}} > \frac{32 \cdot 10^{-6}}{\text{ESR}} = 1066\mu\text{F}$$

To obtain some margin and better thermal spread, the final choice is to use two 680 μF capacitors in parallel.

From Kirchoff's voltage law we can calculate the maximum voltage stress on the output diode:

Equation 32

$$V_{\text{off-diode}} = V_{\text{out}} + \frac{N_{\text{S}}}{N_{\text{P}}} \cdot V_{\text{inmax}} = 109\text{V}$$

Finally, adding a 10% margin, the STPS20120D has been selected.

5 Startup network design

To allow the circuit to start as soon as the line voltage is applied, it is necessary to pre-charge both C_5 and C_8 capacitances.

A resistor connected to the DC bus directly makes the pre-charge of C_5 electrolytic capacitance. The circuit must start at a minimum DC input voltage of 250 V. The current required by the L6565 driver during the startup time determines the $(R_1 + R_2 + R_3 + R_4)$ value. Considering that the L6565 driver needs a 0.07 mA maximum startup current, we obtain:

Equation 33

$$(R_1 + R_2 + R_3 + R_4) < \frac{V_{inmin}}{I_{SU}} = \frac{250V}{0.07mA} \cong 3.6M\Omega$$

Startup resistance must be lower than 3.6 M Ω to reach the best trade-off between power dissipation and time-to-start. As a consequence, before choosing the startup resistor, we must determine the C_5 capacitance value, which is set according to another requirement. C_5 must be able to supply the L6565 driver until the steady state behavior of the converter is established. The time from bench verification is 20 ms maximum. Given a L6565 minimum hysteresis-voltage (difference between startup threshold and undervoltage threshold) of 3.7 V, the voltage across C_5 must decrease less than 3.7 V during the startup period. From the L6565 datasheet we know that maximum quiescent current after turn-on is 3.5 mA, so C_5 must be chosen such that:

Equation 34

$$\Delta V = \frac{I_Q \cdot \Delta t}{C_5} < 3.7V \Rightarrow C_5 > \frac{3.5mA \cdot 20ms}{3.7V} \cong 19\mu F$$

$C_5=33 \mu F$ is a good choice to guarantee a good margin.

Finally, we can set the startup resistance value to reduce time-to-start and simultaneously optimize standby power dissipation. The L6565 has a maximum startup threshold of 14.5 V, therefore the maximum time-to-start is approximately:

Equation 35

$$\text{Time - to - start: } \frac{C_5 \cdot 14.5V}{\left(\frac{V_{inmin}}{(R_1 + R_2 + R_3 + R_4)}\right) - I_{SU}} \leq 2 \text{ sec} \Rightarrow (R_1 + R_2 + R_3 + R_4) \leq 808k\Omega$$

A good choice is to put in series four 200 k Ω resistors ($R_1 = R_2 = R_3 = R_4 = 200 \text{ k}\Omega$), which dissipate less than 1 W of standby power.

The pre-charge of C_8 base capacitance is carried out by connecting it to the OUT pin of the L6565 through a diode in series with a 2.2 k Ω resistor.

6 Frequency response and loop compensation

The transfer function in the complex frequency domain of the discontinuous current mode (DCM) flyback converter with L6565 driver is given by:

Equation 36

$$G_1(s) = \frac{V_{out}(s)}{V_{comp}(s)} = \frac{n \cdot R_{out} \cdot (1 - D_{max})}{2 \cdot R_S \cdot (1 + D_{max})} \cdot \frac{(1 + s \cdot C_{out} \cdot ESR) \left(1 - s \cdot \frac{L_p D_{max}}{n^2 R_{out} (1 - D_{max})^2} \right)}{1 + s \cdot \frac{C_{out} R_{out}}{1 + D_{max}}}$$

The parameters and values are listed in [Table 3](#).

Table 3. Transfer function main parameters

Parameter	Description	Value
n	Primary/secondary turn-ratio	10
R _S	Sensing resistor	0.8 Ω
D _{max}	Maximum duty-cycle	0.5
ESR	Electrolytic series resistance	16 mΩ
R _{out} =V _{out} /I _{out}	Output load	7.2 Ω
C _{out}	Output capacitance	2 mF
L _p	Primary inductance	1.56 mH

It is worth noting that the transfer function has one pole and one zero on the left half plane and an additional zero on the right half plane. The RHP zero is very difficult, if not impossible, to compensate and therefore must be kept well beyond the closed-loop bandwidth. As a result, the transient response of such a system will not be extremely fast.

Poles and zeros are given in [Equation 37](#) and [Equation 38](#):

Equation 37

$$f_p = 25\text{Hz}; f_{z1} = 3.5 \cdot 10^5\text{Hz}; f_{z2} = 5 \cdot 10^3\text{Hz}$$

A good line and load regulation implies a high DC gain, thus the open loop gain should have a pole at the origin. Normally in this case we need a feedback network like the one in [Figure 9](#).

Figure 9. Converter feedback network

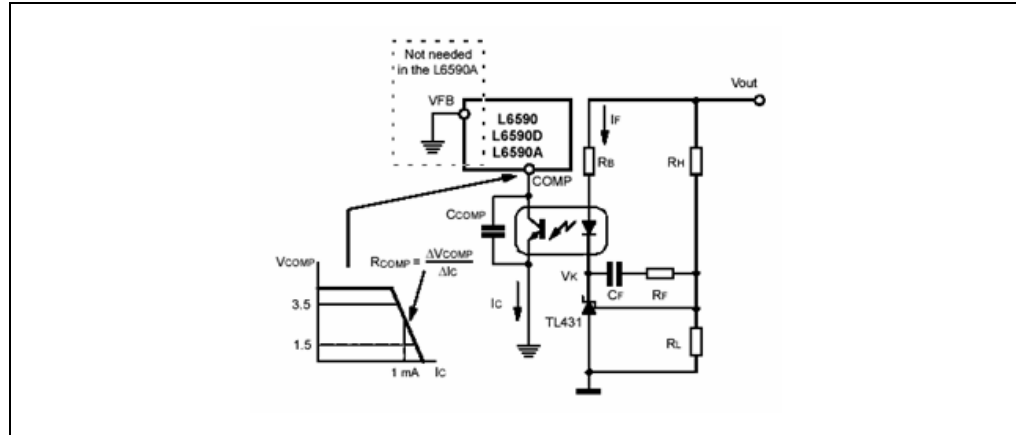

Its transfer function, which comprises a pole at the origin and a zero-pole pair, is given by:

Equation 38

$$G_2(s) = \frac{V_{comp}(s)}{V_{out}(s)} = \frac{CTR_{max} \cdot R_{COMP}}{R_B R_H C_F} \cdot \frac{1}{s} \cdot \frac{1 + s(R_H + R_F)C_F}{1 + sR_{COMP}C_{comp}}$$

The task of the control loop design is then to determine the transfer function $G_2(s)$ to ensure that the resulting closed-loop system is stable and performs well in terms of dynamic response, and line and load regulation. It is well known that the characteristics of the closed-loop system can be inferred from its open loop transfer function properties, that is $G(s) = G_1(s) \cdot G_2(s)$.

Frequency response requirements are summarized below:

1. Optimum dynamic performance requires a large gain bandwidth, that is the open-loop cross-over frequency f_c to be typically chosen equal to $f_{sw}/5$ ($f_c = 10$ kHz).
2. Phase margin φ_m comprised between 45° and 90° is used as a design guideline. This ensures fast transient response with very little ringing. Sometimes this is not enough and so phase shift should be lower than 180° at any frequency below f_c , because a phase shift over 180° would result in a conditionally stable system.
3. Good load and line regulation implies a high DC gain (this requirement is ensured by the feedback network, whose transfer function has a pole at the origin).

First choose a typical value for $R_L = R_{22} = 2.7$ k Ω .

From the L6565 datasheet we know that $I_{comp} = 5$ mA (source current) and $R_{comp} = 15$ k Ω . and can obtain:

Equation 39

$$R_B = R_{24} < \frac{V_{out} - (V_{ref} - V_{diode})}{I_{comp}} = \frac{24V - 3.5V}{5mA} = 4.1$$
 k Ω

$R_{24} = 1.5$ k Ω is a good choice. It is good practice to put a 3.3 k Ω resistor ($R_{23} = 3.3$ k Ω) in parallel to the photodiode.

The resistive partition must be set with high precision according to the following formula:

Equation 40

$$R_{\text{high}} = R_{22} \cdot \frac{V_{\text{out}} - V_{\text{ref}}}{V_{\text{ref}}} = 23.2\text{k}\Omega$$

There is no next close commercial value so it is a good idea to put two 47 kΩ resistors (R₁₉ = R₂₀ = 47 kΩ) in series.

Now C₁₁ (C_{comp}), C₁₃ (C_F) and R₂₁ (R_F) must be set in order to satisfy frequency response requirements.

A good choice is to set the pole of G₂(s) so as to cancel the low frequency zero of G₁(s):

Equation 41

$$\frac{1}{2\pi \cdot R_{\text{comp}} \cdot C_{\text{comp}}} = 5\text{kHz} \Rightarrow C_{11} = C_{\text{comp}} \cong 2.12\text{nF}$$

The next close commercial value for C₁₁ = 2.2 nF has been chosen.

Similarly C₁₃ and R₂₁ have been determined by setting the corresponding zero close to the pole of G₁(s) and imposing the open-loop gain to cross the 0 dB axis only once at f = f_c = 10 kHz:

Equation 42

$$\begin{cases} \frac{1}{2\pi \cdot (R_H + R_F) \cdot C_F} = 400\text{Hz} \Rightarrow C_{13} = 10\text{nF} \\ |G(j\omega)|_{\omega = 2\pi \cdot 10^4 \text{ rad/sec}} = 1 \Rightarrow R_{21} \cong 15\text{k} \end{cases}$$

In such a way we ideally get a phase margin of 90 degrees and an adequate closed-loop bandwidth.

Figure 10 shows Bode plots of the stabilized open loop transfer function.

Figure 10. Stabilized open loop transfer function G(s) = G₁(s) · G₂(s) (Bode plots)

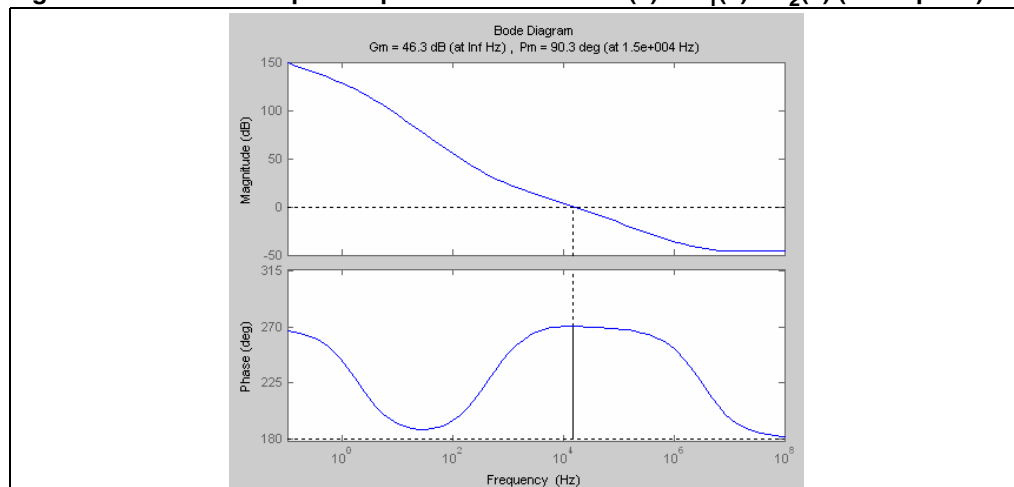

As expected, all requirements have been satisfied by properly choosing the feedback network. Gain bandwidth is quite large, phase margin is around 90°, and system stability margin is improved.

7 Efficiency, waveforms and experimental results

Overall efficiency variation versus output power is illustrated in [Figure 11](#) for two different values of input voltage.

Figure 11. Overall efficiency versus output power for two different values of input voltage

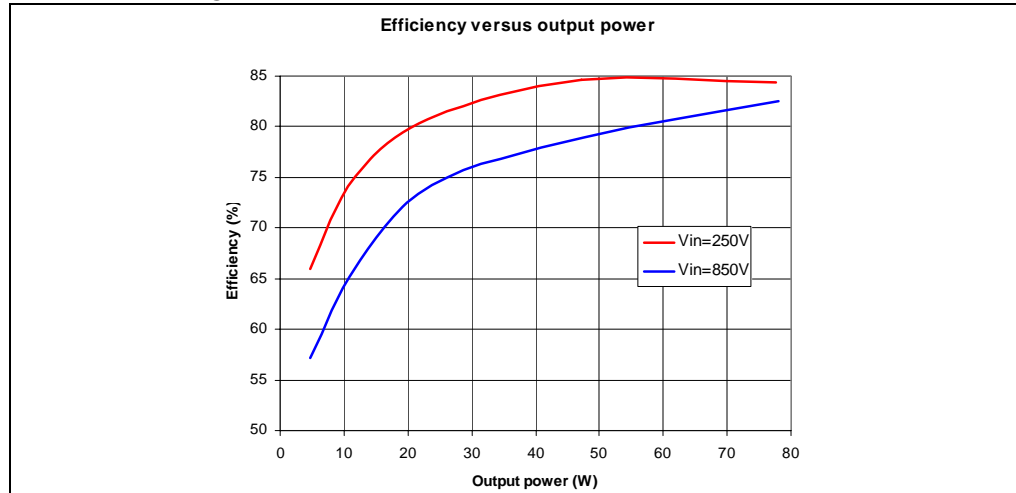

It is worth noting that with low input voltage (red curve), total efficiency is over 80%, and at medium and high load working conditions, reaching almost 85%. Efficiency decreases with input voltage. However, it is above 75% at loads higher than 30% even with maximum input voltage.

Theoretical assumptions made so far have been validated with the use of a demonstration board. A complete description of this board has been carried out and the most meaningful waveforms in any working condition are shown in [Figure 12](#) through [Figure 17](#).

[Figure 12](#), [Figure 13](#) and [Figure 14](#) show the prototype steady state behavior, by indicating the gate voltage (blue waveform), the base current (violet waveform) and the collector voltage (sky blue waveform) at maximum load for different input voltages.

Figure 12. Minimum input voltage-maximum load (250 V-80 W) in steady state

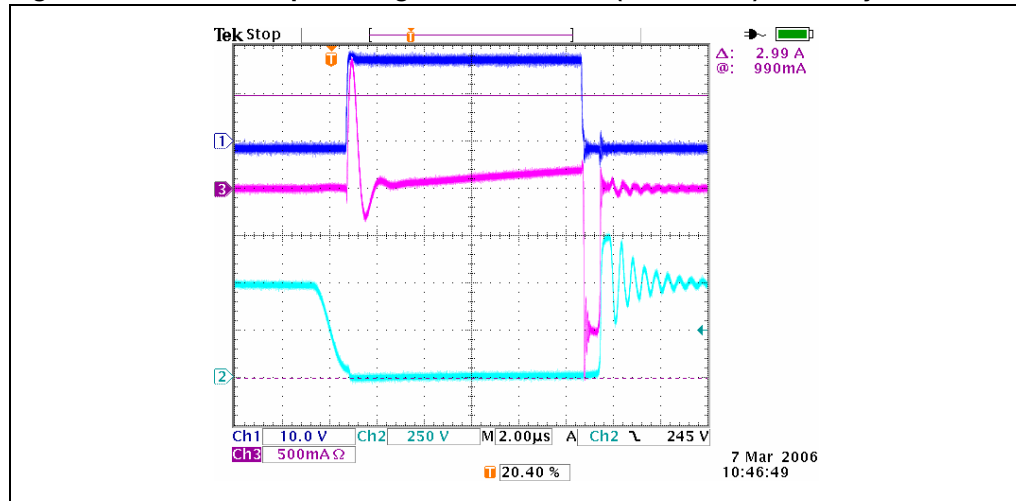

Figure 13. Medium input voltage-maximum load (500 V-80 W) in steady state

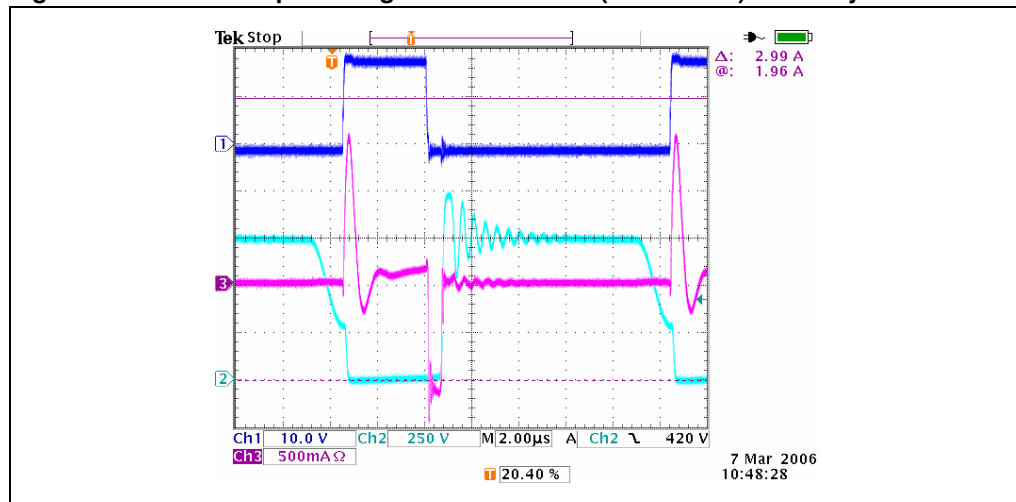
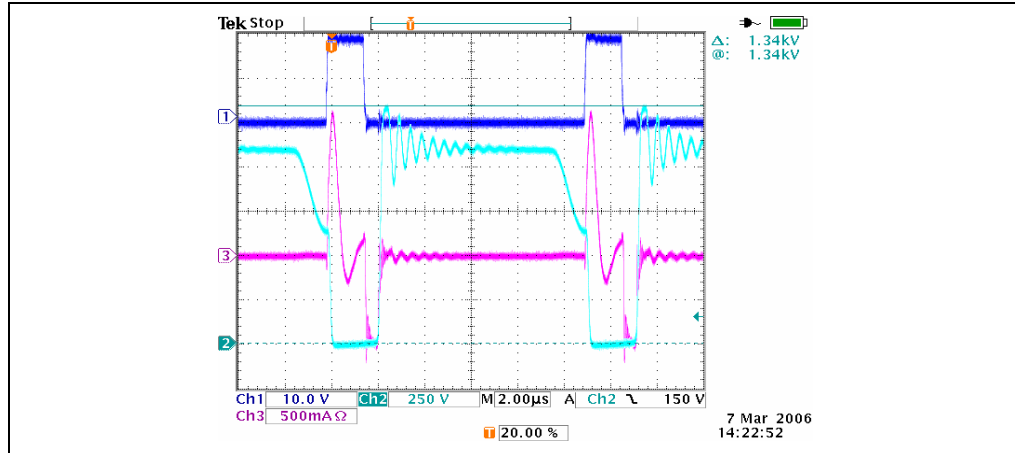

Figure 14. Maximum input voltage-maximum load (850 V-80 W) in steady state



Waveforms in [Figure 15](#), [Figure 16](#), and [Figure 17](#) describe the function of the converter at both low and high load conditions with the same input rectified voltage.

Figure 15. Very low load condition (750 V-5 W)

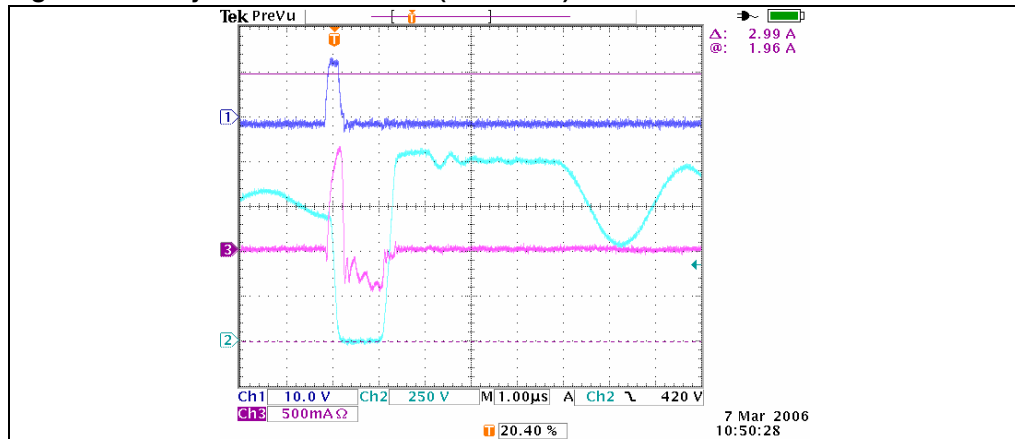

Figure 16. Low load condition (750 V-24 W)

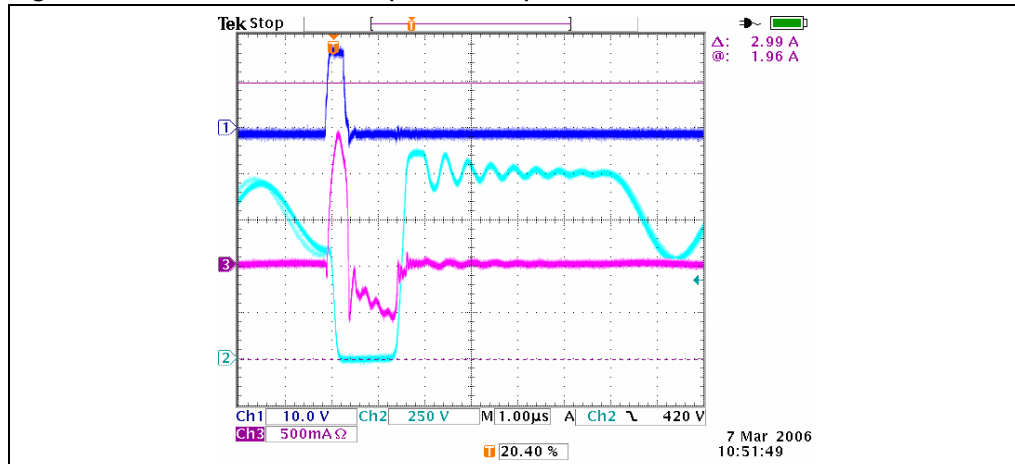
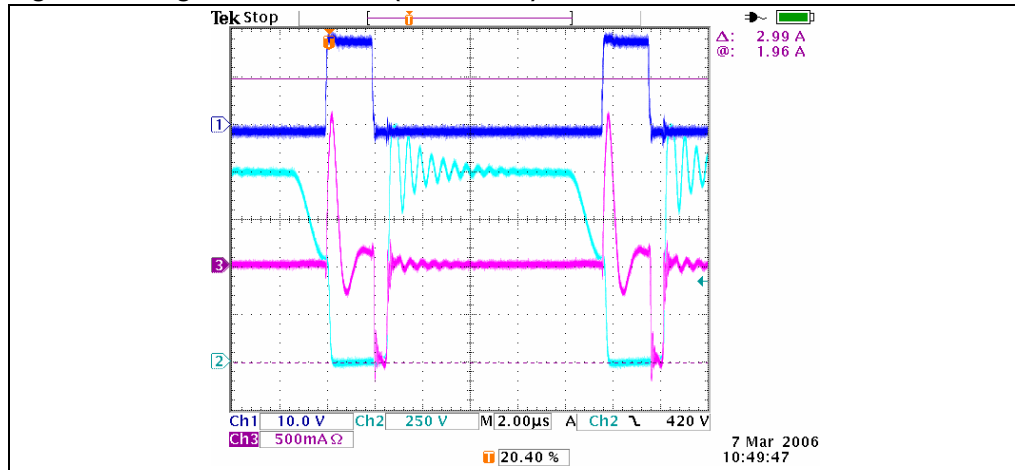
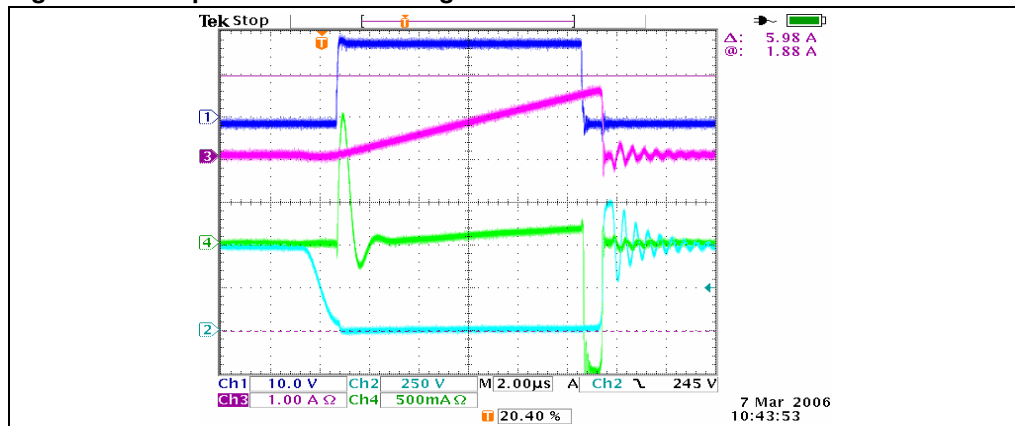

Figure 17. High load condition (750 V-80 W)



The waveform in *Figure 18* illustrates the function of the proportional base driving network. In this graph, collector current is the violet line, while the base current line is sky blue.

Figure 18. Proportional base driving circuit relevant waveform



8 PCB layout and list of material

The PCB (printed circuit board) is shown in [Figure 19](#) and [Figure 20](#).

Figure 19. PCB layout (top view)

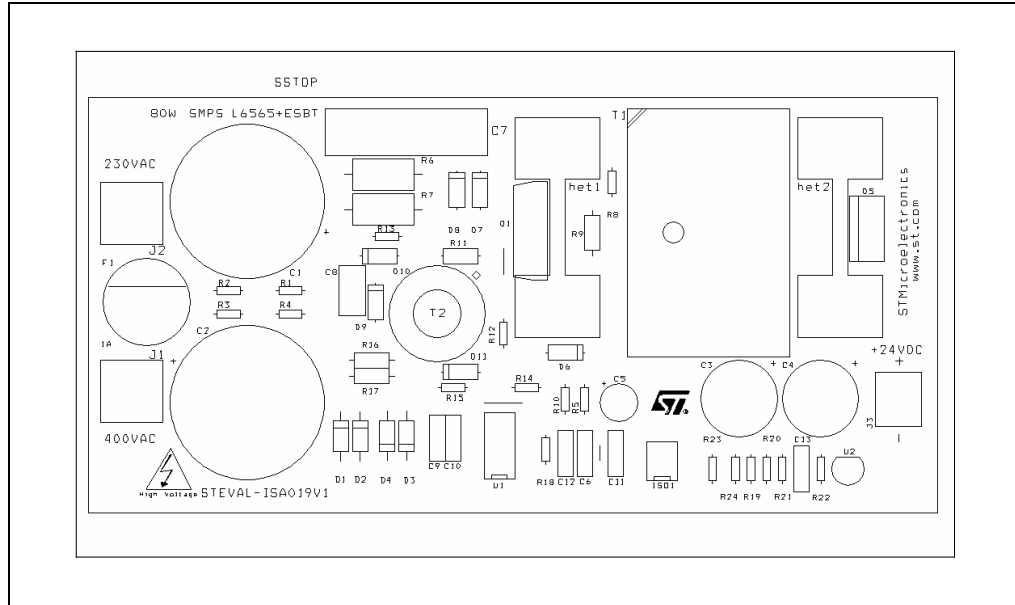
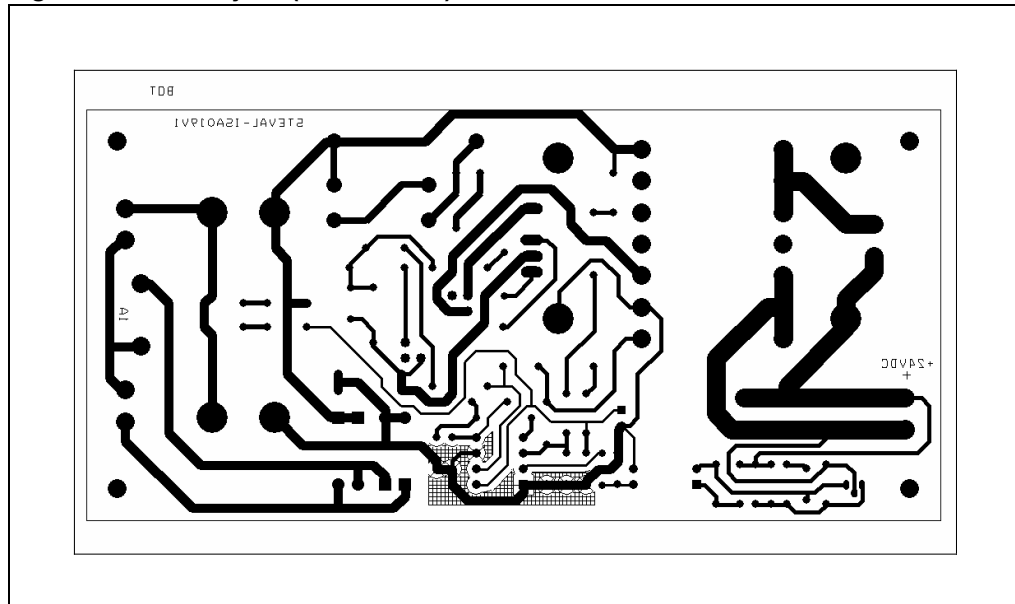

Figure 20. PCB layout (bottom view)



9 Bill of material

Table 4. Bill of material

Part	Description
C1,C2	220 μ F/450 V
C3,C4	1000 μ F/35 V
C5	33 μ F/50 V
C6	100 nF
C7	6n8
C8	220 n
C9	470 pF
C10	10 pF
C11	2n2
C12	1 nF
C13	10 n
D1,D2,D3,D4	1N4007
D5	STPS20120D
D6	1N4007
D7,D8,D10	STTH108
D9	3 V Zener
D11	1N4148
R1, R2, R3, R4	200 k Ω /0.25 W
R5	10 Ω /0.25 W
R6, R7	39 k Ω /2 W
R8, R9, R10	1M1/0.25 W
R11	0.56 Ω /1 W
R12	10 Ω /0.25 W
R13	2.2 Ω /0.25 W
R14	56 k Ω /0.25 W
R15	1 k Ω /0.25 W
R16, R17	1.6 Ω /1 W
R18	10 k Ω /0.25 W
R19, R20	47 k Ω /0.25 W
R21	15 k Ω /0.25 W
R22	2.7 k Ω /0.25 W
R23	3.3 k Ω /0.25 W

Table 4. Bill of material (continued)

Part	Description
R24	1.5 k Ω /0.25 W
Q1	STC04IE170HV
J1, J2	ARK700I/2
J3	ARK500/2
U1	L6565
U2	TL431
ISO1	PC817
F1	FUSE 2 A / 250 V
Fuse holder	HA122100, RM = 10 mm
T1	TRONIC 0600387
T2	VOGT SL0512202101
het1, het2	V7477X

10 Board modifications

This paragraph has been added following the release of a more recent version of the board (STEVAL-ISA019V2). For the design procedure and rules, all the preceding paragraphs remain valid. Working conditions have not been changed. The new version was released to take advantage of the size reduction of the SMD components and to insert a new transformer with better coupling between primary inductance and auxiliary winding. The new transformer has been provided in accordance with the application requirements by Delta Electronics Inc. Moreover, the J2 connector (voltage doubler) has been removed from the board and an NTC resistor 10R (Epcos B57237S100M) was added in series with the input line to suppress overcurrent peaks during the charge of the bulk capacitor. The complete solution is shown in [Figure 21](#).

Figure 21. STEVAL-ISA019V2

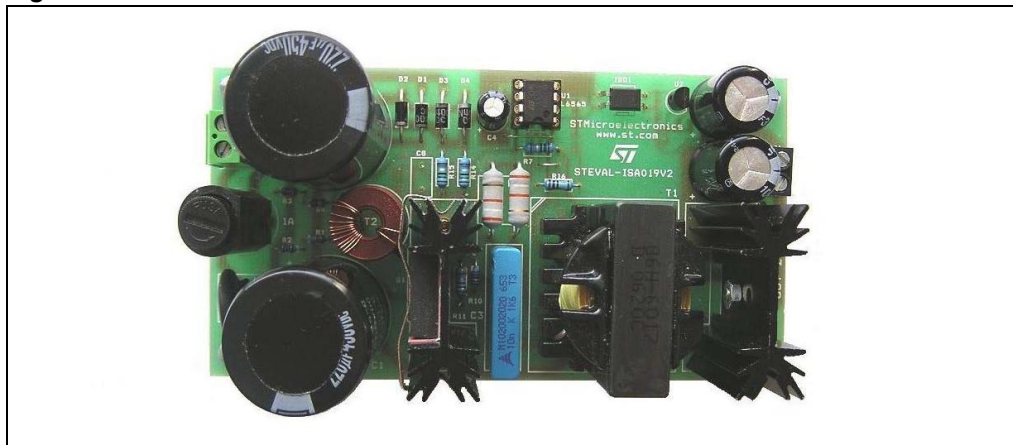

In [Figure 22](#) the complete schematic of the STEVAL-ISA019V2 is provided.

Figure 23. Power transformer Delta 86H-6017

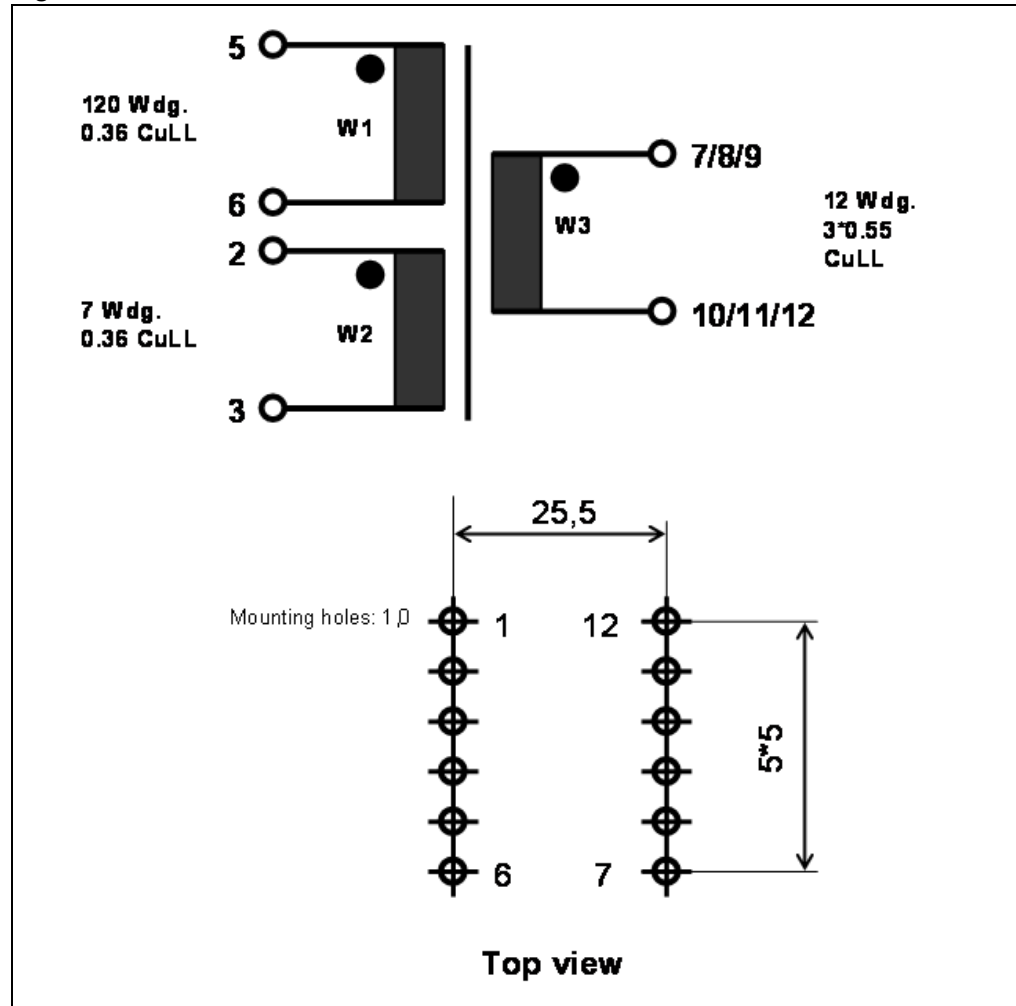

The STEVAL-ISA019V2 printed circuit board is shown in [Figure 24](#), [Figure 25](#) and [Figure 26](#).

Figure 24. Silk screen (top side)

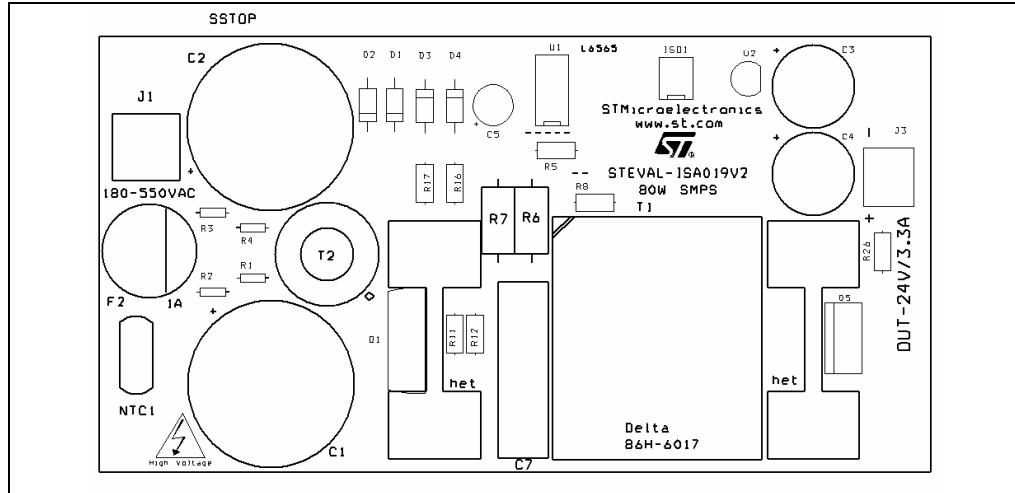

Figure 25. Silk screen (bottom side)

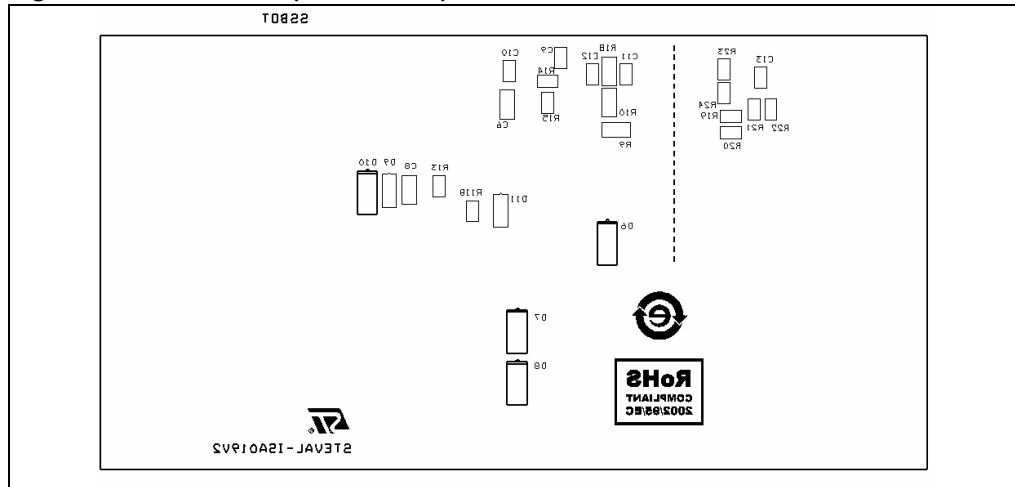
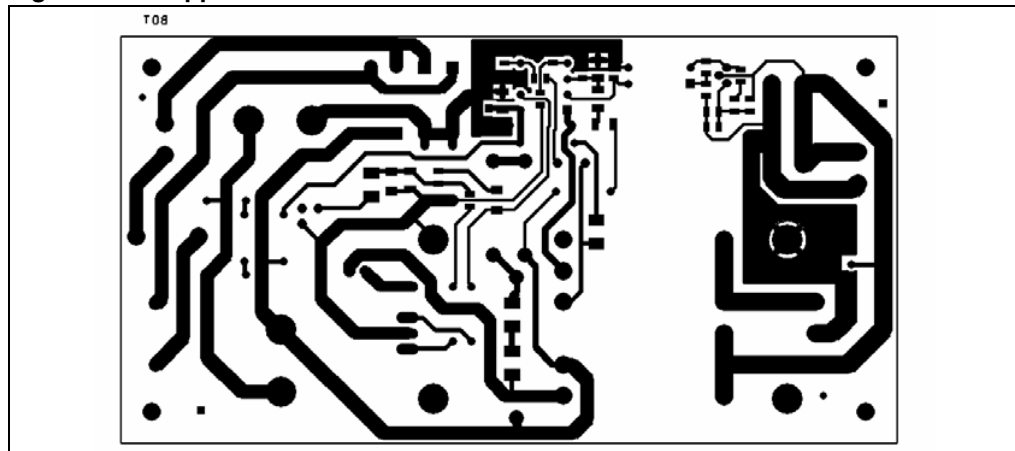

Figure 26. Copper tracks



11 References

- STMicroelectronics application note AN1889 "ESBT STC03DE120 IN 3-PHASE AUXILIARY POWER SUPPLY"
- STMicroelectronics application note AN1262 "OFFLINE FLYBACK CONVERTERS DESIGN METHODOLOGY WITH THE L6590 FAMILY"
- STMicroelectronics application note AN2131 "HIGH POWER 3-PHASE AUXILIARY POWER SUPPLY DESIGN BASED ON L5991 AND ESBT STC08DE150"
- STMicroelectronics L6565 datasheet "QUASI-RESONANT SMPS CONTROLLER"
- STMicroelectronics STC04IE170HV datasheet "Emitter switched bipolar transistor ESBT[®] 1700 V - 4A - 0.17 Ω "
- "Switching Power Supply Design", McGraw-Hill, Inc.

12 Revision history

Table 5. Document revision history

Date	Revision	Changes
28-Mar-2007	1	First issue
10-Apr-2007	2	<i>Equation 5</i> and <i>Equation 15</i> modified
02-Jul-2007	3	ESBT part number has been updated
20-May-2009	4	<ul style="list-style-type: none">– <i>Section 10: Board modifications</i> added– Minor text changes throughout the document

Please Read Carefully:

Information in this document is provided solely in connection with ST products. STMicroelectronics NV and its subsidiaries ("ST") reserve the right to make changes, corrections, modifications or improvements, to this document, and the products and services described herein at any time, without notice.

All ST products are sold pursuant to ST's terms and conditions of sale.

Purchasers are solely responsible for the choice, selection and use of the ST products and services described herein, and ST assumes no liability whatsoever relating to the choice, selection or use of the ST products and services described herein.

No license, express or implied, by estoppel or otherwise, to any intellectual property rights is granted under this document. If any part of this document refers to any third party products or services it shall not be deemed a license grant by ST for the use of such third party products or services, or any intellectual property contained therein or considered as a warranty covering the use in any manner whatsoever of such third party products or services or any intellectual property contained therein.

UNLESS OTHERWISE SET FORTH IN ST'S TERMS AND CONDITIONS OF SALE ST DISCLAIMS ANY EXPRESS OR IMPLIED WARRANTY WITH RESPECT TO THE USE AND/OR SALE OF ST PRODUCTS INCLUDING WITHOUT LIMITATION IMPLIED WARRANTIES OF MERCHANTABILITY, FITNESS FOR A PARTICULAR PURPOSE (AND THEIR EQUIVALENTS UNDER THE LAWS OF ANY JURISDICTION), OR INFRINGEMENT OF ANY PATENT, COPYRIGHT OR OTHER INTELLECTUAL PROPERTY RIGHT.

UNLESS EXPRESSLY APPROVED IN WRITING BY AN AUTHORIZED ST REPRESENTATIVE, ST PRODUCTS ARE NOT RECOMMENDED, AUTHORIZED OR WARRANTED FOR USE IN MILITARY, AIR CRAFT, SPACE, LIFE SAVING, OR LIFE SUSTAINING APPLICATIONS, NOR IN PRODUCTS OR SYSTEMS WHERE FAILURE OR MALFUNCTION MAY RESULT IN PERSONAL INJURY, DEATH, OR SEVERE PROPERTY OR ENVIRONMENTAL DAMAGE. ST PRODUCTS WHICH ARE NOT SPECIFIED AS "AUTOMOTIVE GRADE" MAY ONLY BE USED IN AUTOMOTIVE APPLICATIONS AT USER'S OWN RISK.

Resale of ST products with provisions different from the statements and/or technical features set forth in this document shall immediately void any warranty granted by ST for the ST product or service described herein and shall not create or extend in any manner whatsoever, any liability of ST.

ST and the ST logo are trademarks or registered trademarks of ST in various countries.

Information in this document supersedes and replaces all information previously supplied.

The ST logo is a registered trademark of STMicroelectronics. All other names are the property of their respective owners.

© 2009 STMicroelectronics - All rights reserved

STMicroelectronics group of companies

Australia - Belgium - Brazil - Canada - China - Czech Republic - Finland - France - Germany - Hong Kong - India - Israel - Italy - Japan - Malaysia - Malta - Morocco - Philippines - Singapore - Spain - Sweden - Switzerland - United Kingdom - United States of America

www.st.com