

MAX16955 Evaluation Kit

Evaluates: MAX16955

General Description

The MAX16955 evaluation kit (EV kit) is a fully assembled and tested PCB that contains all the components necessary to evaluate the performance of the MAX16955 synchronous PWM step-down controller. The device is available in a 16-pin TSSOP package and features an exposed pad for enhanced thermal dissipation.

The EV kit requires a 6V to 36V power supply for normal operation. The EV kit output is configured to 5V and can deliver up to 5A output current. The EV kit can be easily reconfigured to operate the controller in continuous PWM mode, SKIP mode, or external synchronization operation. The controller switching frequency is set to 400kHz. The EV kit includes a jumper to enable the circuit and an LED to monitor the power-good output.

Features

- ◆ 6V to 36V Input Range
- ◆ 5V at Up to 5A Output
- ◆ 400kHz Switching Frequency
- ◆ Selectable Forced Fixed-Frequency PWM Mode, SKIP Mode, or External Synchronization
- ◆ Power-Good LED Indicator
- ◆ Enable Input
- ◆ Cycle-by-Cycle Current Limit and Thermal Protection
- ◆ Proven PCB Layout
- ◆ Fully Assembled and Tested

Ordering Information appears at end of data sheet.

Component List

DESIGNATION	QTY	DESCRIPTION
BIAS, EN, FSYNC, OUT (x2), SUP (x2)	7	Red multipurpose test points
C1	1	0.22 μ F \pm 10%, 50V X7R ceramic capacitor (0805) Murata GRM21BR71H224K
C2	1	47 μ F \pm 20%, 50V electrolytic capacitor (D8) Panasonic EEE-FK1H470XP
C4	1	0.1 μ F \pm 10%, 50V X7R ceramic capacitor (0603) Murata GRM188R71H104K
C5, C9	0	Not installed, ceramic capacitors (0603)
C6	1	100 μ F \pm 20%, 6.3V X5R ceramic capacitor (1210) TDK C3325X5R0J107M
C7	1	47 μ F \pm 20%, 6.3V X7R ceramic capacitor (1210) Murata GRM32ER70J476M
C8	1	1 μ F \pm 10%, 16V X7R ceramic capacitor (0603) Murata GRM188R71C105K
C10	1	6800pF \pm 10%, 50V X7R ceramic capacitor (0603) Murata GRM188R71H682K

DESIGNATION	QTY	DESCRIPTION
C11	1	4.7 μ F \pm 10%, 50V X7R ceramic capacitor (1206) Murata GRM31CR71H475K
C13	1	4.7 μ F \pm 10%, 50V X7R ceramic capacitor (1210) Murata GRM32ER71H475K
D1	1	60V, 3A Schottky diode (SMB) Diodes Inc. B360B-13-F
D2	1	Red LED (0603)
D3	0	Not installed, Schottky diode (3 SOT23)
JU1	1	3-pin header
JU2	1	2-pin header
L1	1	5.5 μ H \pm 20%, 10A inductor Würth 744325550
N1	1	40V, 6A dual n-channel MOSFET (8 SO) Fairchild FDS8949
PGND (x5), SGND	6	Black multipurpose test points
R2, R5, R6	0	Not installed, resistors (0603)
R4	1	0.015 Ω \pm 1%, 1/2W resistor (1206) IRC LRF1206LF-01-R015-F
R7, R12	2	0 Ω \pm 5% resistors (0603)
R8	1	66.5k Ω \pm 1% resistor (0603)

MAX16955 Evaluation Kit

Evaluates: MAX16955

Component List (continued)

DESIGNATION	QTY	DESCRIPTION
R9	1	13k Ω \pm 1% resistor (0603)
R10	1	10k Ω \pm 5% resistor (0603)
R11	1	51.1k Ω \pm 1% resistor (0603)
U1	1	Synchronous buck converter (16 TSSOP-EP) Maxim MAX16955AUE/V+

DESIGNATION	QTY	DESCRIPTION
—	2	Shunts
—	1	PCB: MAX16955 EVALUATION KIT

Component Suppliers

SUPPLIER	PHONE	WEBSITE
Diodes Incorporated	805-446-4800	www.diodes.com
Fairchild Semiconductor	888-522-5372	www.fairchildsemi.com
IRC, Inc.	361-992-7900	www.irctt.com
Murata Electronics North America, Inc.	770-436-1300	www.murata-northamerica.com
Panasonic Corp.	800-344-2112	www.panasonic.com
TDK Corp.	847-803-6100	www.component.tdk.com
Würth Elektronik GmbH & Co. KG	201-785-8800	www.we-online.com

Note: Indicate that you are using the MAX16955 when contacting these component suppliers.

Quick Start

Required Equipment

- MAX16955 EV kit
- 12V, 1A power supply
- An electronic load capable of sinking 1A (e.g., HP6060B)
- Two digital voltmeters (DVMs)

Procedure

The EV kit is fully assembled and tested. Follow the steps below to verify board operation:

- 1) Verify that a shunt is installed across pins 2-3 on jumper JU1.
- 2) Verify that a shunt is not installed across jumper JU2 (output enabled).
- 3) Connect the load across the OUT and PGND test points.
- 4) Connect the first DVM across the SUP and PGND test points.
- 5) Connect the second DVM across the OUT and PGND test points.
- 6) Connect the power supply's positive and ground terminals to the SUP and PGND test points, respectively.

- 7) Turn on the power supply and set to 12V with a 1A current limit.
- 8) Enable the 1A electronic load.
- 9) Verify that the red LED (D2) is off and the DVM at OUT measures 5V.

Detailed Description of Hardware

The MAX16955 EV kit is a fully assembled and tested PCB that contains all the components necessary to evaluate the performance of the MAX16955 synchronous PWM step-down controller. The device is available in a 16-pin TSSOP package and features an exposed pad for thermal dissipation. The device has a 3.5V to 36V input voltage range. The EV kit circuit is designed to operate from a single DC power supply ranging from 6V to 36V.

The EV kit is configured to output 5V and provides up to 5A load current at the OUT and PGND test points. The switching frequency is set to 400kHz using resistor R8. The peak inductor current is set to 5.3A using resistor R4. The EV kit can be configured to operate in forced fixed-frequency PWM mode, low-quiescent current SKIP mode, or external synchronization using jumper JU1. The EV kit features test points to evaluate the enable (EN) feature and to monitor the BIAS output voltage. A red LED (D2) is available to monitor the power-good (PGOOD) output signal.

MAX16955 Evaluation Kit

Evaluates: MAX16955

Table 1. Jumper Descriptions (JU1, JU2)

JUMPER	SHUNT POSITION	DESCRIPTION
JU1	1-2	Connects FSYNC to VBIAS to enable continuous PWM mode.
	2-3*	Connects FSYNC to AGND to enable SKIP mode under light-load conditions.
	Open	When FSYNC is unconnected, or when a clock source is present, continuous PWM mode is enabled. SYNC can be used to synchronize with other supplies when a clock source is present.
JU2	Closed	Connects EN to AGND (shutdown).
	Open*	Connects EN to VSUP through a pullup resistor (normal operation).

*Default position.

Modes of Operation (JU1)

Jumper JU1 configures the EV kit for external synchronization, forced fixed-frequency PWM, or SKIP mode operation. Install a shunt across pins 1-2 on JU1 to operate the EV kit in forced fixed-frequency PWM mode. Place a shunt across pins 2-3 on JU1 to operate in SKIP mode. Remove the shunt on JU1 when synchronizing, using an external digital clock signal at the FSYNC and SGND test points. Refer to the *Forced Fixed-Frequency PWM Mode* and *Light-Load Low-Quiescent Operating (SKIP) Mode* sections in the MAX16955 IC data sheet for additional information. See Table 1 for JU1 configuration.

For external synchronization, apply a digital signal at the FSYNC and SGND test points with a frequency between 220kHz and 1.1MHz. For proper frequency synchronization, FSYNC's input frequency must be at least 110% of the EV kit's programmed internal oscillator frequency. When FSYNC is driven with an external digital clock, the device synchronizes to the rising edge of the external clock. The digital square-wave clock source at FSYNC must provide the following signal qualities:

- 0 to 0.4V logic-low
- 1.4V to 5.5V logic-high
- 220kHz to 1.1MHz input frequency
- 100ns minimum pulse width

Enable Control (JU2)

The EV kit output is enabled through pullup resistor R11 when the power source applied between the SUP and PGND test points is greater than 1.8V. To enable the EV kit output, remove the shunt on jumper JU2. To disable the EV kit output, install a shunt on JU2. See Table 2 for JU2 configuration. If the EN pin is toggled from low to high, the switching regulator shuts down and remains off until the output voltage decays to 1.25V. At that point the EV kit output turns on using the soft-start sequence.

Switching Frequency

The controller's approximate switching frequency is set to 400kHz by resistor R8. Replace resistor R8 with a new

resistor value to set the switching frequency between 220kHz and 1MHz. Refer to the *Setting the Switching Frequency* section in the MAX16955 IC data sheet for selecting R8 when reconfiguring the EV kit switching frequency. When reconfiguring the EV kit switching frequency, it is necessary to replace the compensation network components C9, C10, R9, and power components. Refer to the *Design Procedure* section in the MAX16955 IC data sheet for computing new compensation and power component values.

Configuring the Output Voltage (OUT)

The EV kit step-down controller's output voltage (OUT) is configured to 5V. OUT can be reconfigured between 1V and 12V by removing resistor R7 and inserting feedback resistors at the R5 and R6 (0603) PCB pads. To configure the EV kit's output voltage, refer to the *Setting the Output Voltage* section in the MAX16955 IC data sheet for instructions on selecting resistor values. Also refer to the *Effective Input-Voltage Range* and *Output Capacitor* sections in the MAX16955 IC data sheet. Refer to the *Design Procedure* section in the MAX16955 IC data sheet and modify the compensation network accordingly.

Power-Good Indicator (D2)

The EV kit provides a red LED power-good indicator (D2) to monitor undervoltage and overvoltage conditions at OUT. D2 illuminates when OUT falls below 90% (typ) or rises above 111% (typ) of its nominal regulated voltage.

Peak Inductor Current Limit

The device's current-limit circuit uses differential current-sense inputs (CS and OUT) to limit the peak inductor current. The EV kit peak inductor current is set to 5.3A using resistor R4. Use the following equation to calculate the resistance needed to reconfigure the inductor peak current limit:

$$R4 = \frac{80\text{mV}}{I_{LIM}}$$

where R4 is in milliohms and I_{LIM} is the peak inductor current in amps.

MAX16955 Evaluation Kit

Evaluates: MAX16955

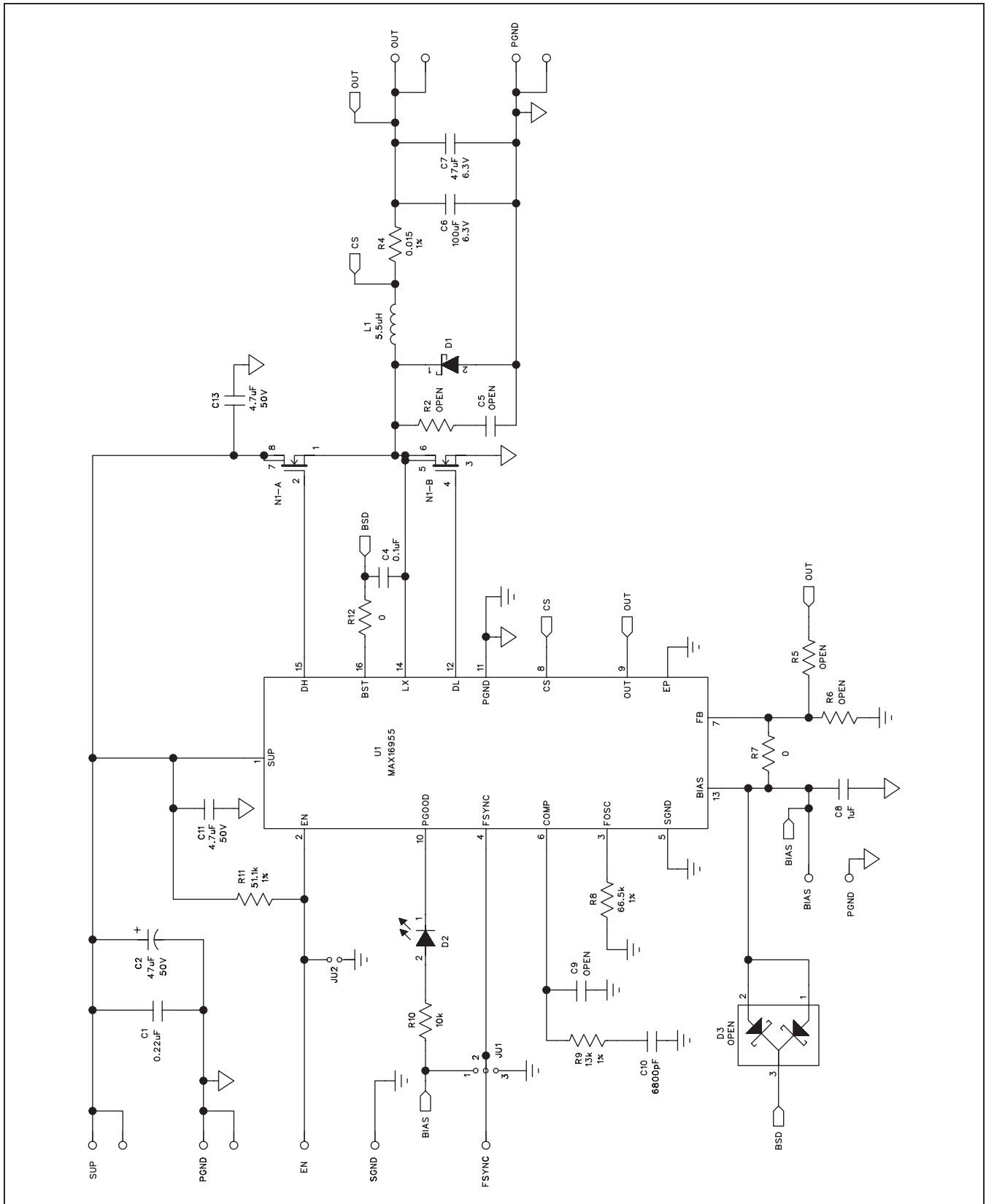

Figure 1. MAX16955 EV Kit Schematic

MAX16955 Evaluation Kit

Evaluates: MAX16955

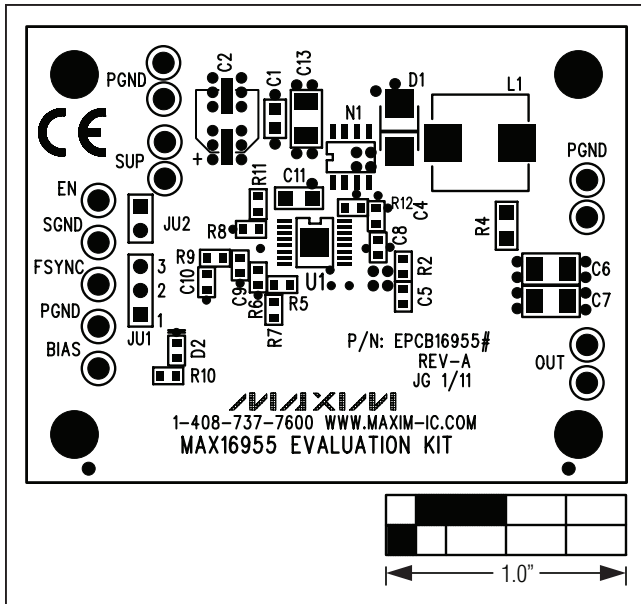

Figure 2. MAX16955 EV Kit Component Placement Guide—Component Side

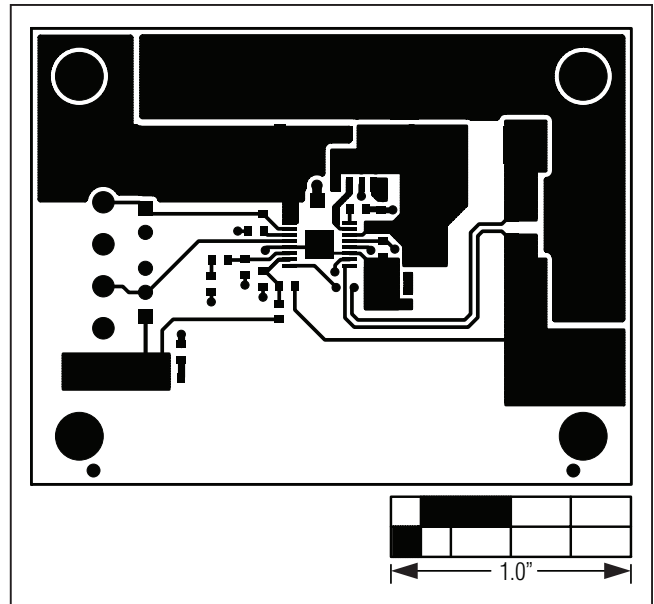

Figure 3. MAX16955 EV Kit PCB Layout—Component Side

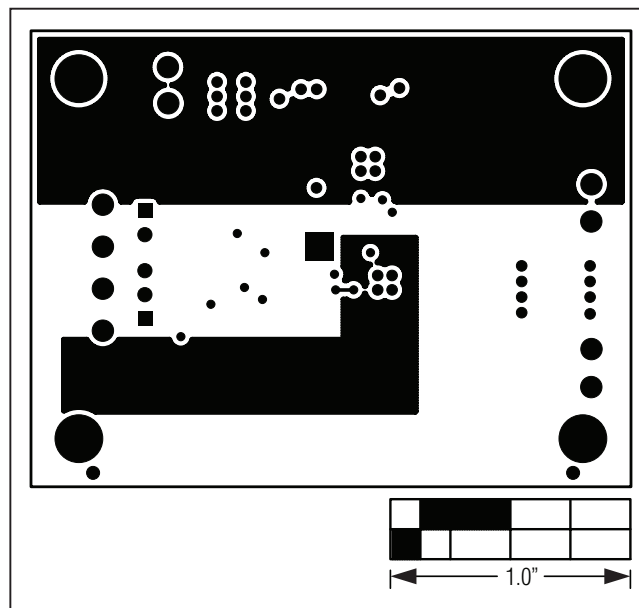

Figure 4. MAX16955 EV Kit PCB Layout—VCC Layer 2

MAX16955 Evaluation Kit

Evaluates: MAX16955

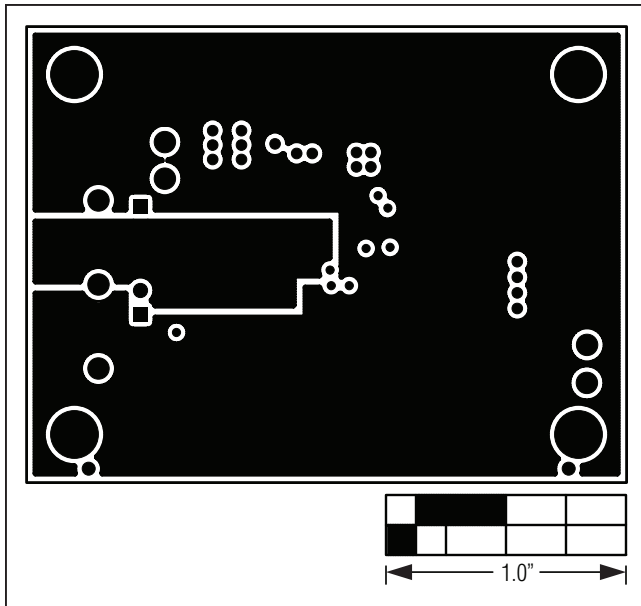

Figure 5. MAX16955 EV Kit PCB Layout—PGND and SGND Layer 3

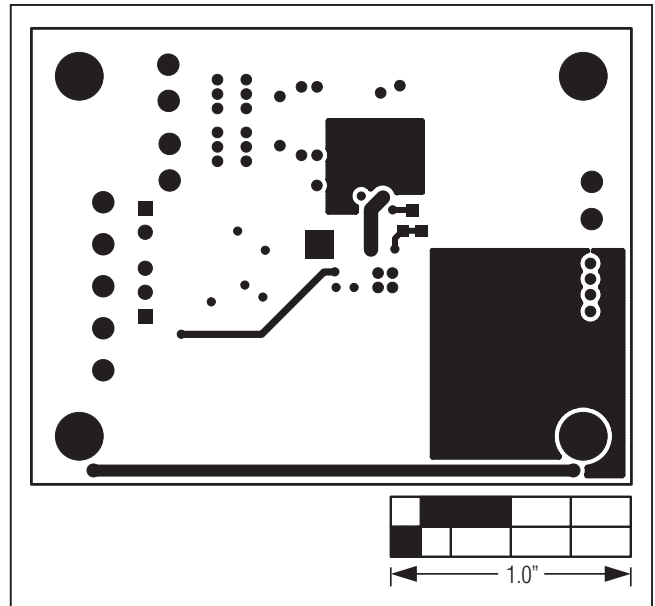

Figure 6. MAX16955 EV Kit PCB Layout—Solder Side

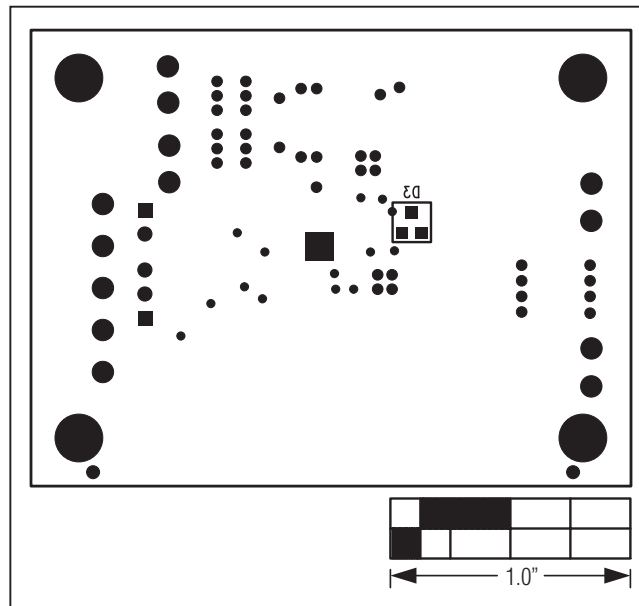

Figure 7. MAX16955 EV Kit Component Placement Guide—Solder Side

MAX16955 Evaluation Kit

Evaluates: MAX16955

Ordering Information

PART	TYPE
MAX16955EVKIT#	EV Kit

#Denotes RoHS compliant.

MAX16955 Evaluation Kit

Evaluates: MAX16955

Revision History

REVISION NUMBER	REVISION DATE	DESCRIPTION	PAGES CHANGED
0	2/11	Initial release	—

Maxim cannot assume responsibility for use of any circuitry other than circuitry entirely embodied in a Maxim product. No circuit patent licenses are implied. Maxim reserves the right to change the circuitry and specifications without notice at any time.

Maxim Integrated Products, 120 San Gabriel Drive, Sunnyvale, CA 94086 408-737-7600 _____ 8

© 2011 Maxim Integrated Products

Maxim is a registered trademark of Maxim Integrated Products, Inc.