

LM101A/LM201A/LM301A Operational Amplifiers

General Description

The LM101A series are general purpose operational amplifiers which feature improved performance over industry standards like the LM709. Advanced processing techniques make possible an order of magnitude reduction in input currents, and a redesign of the biasing circuitry reduces the temperature drift of input current. Improved specifications include:

- Offset voltage 3 mV maximum over temperature (LM101A/LM201A)
- Input current 100 nA maximum over temperature (LM101A/LM201A)
- Offset current 20 nA maximum over temperature (LM101A/LM201A)
- Guaranteed drift characteristics
- Offsets guaranteed over entire common mode and supply voltage ranges
- Slew rate of 10V/μs as a summing amplifier

This amplifier offers many features which make its application nearly foolproof: overload protection on the input

and output, no latch-up when the common mode range is exceeded, and freedom from oscillations and compensation with a single 30 pF capacitor. It has advantages over internally compensated amplifiers in that the frequency compensation can be tailored to the particular application. For example, in low frequency circuits it can be overcompensated for increased stability margin. Or the compensation can be optimized to give more than a factor of ten improvement in high frequency performance for most applications.

In addition, the device provides better accuracy and lower noise in high impedance circuitry. The low input currents also make it particularly well suited for long interval integrators or timers, sample and hold circuits and low frequency waveform generators. Further, replacing circuits where matched transistor pairs buffer the inputs of conventional IC op amps, it can give lower offset voltage and a drift at a lower cost.

The LM101A is guaranteed over a temperature range of -55°C to +125°C, the LM201A from -25°C to +85°C, and the LM301A from 0°C to +70°C.

Fast AC/DC Converter

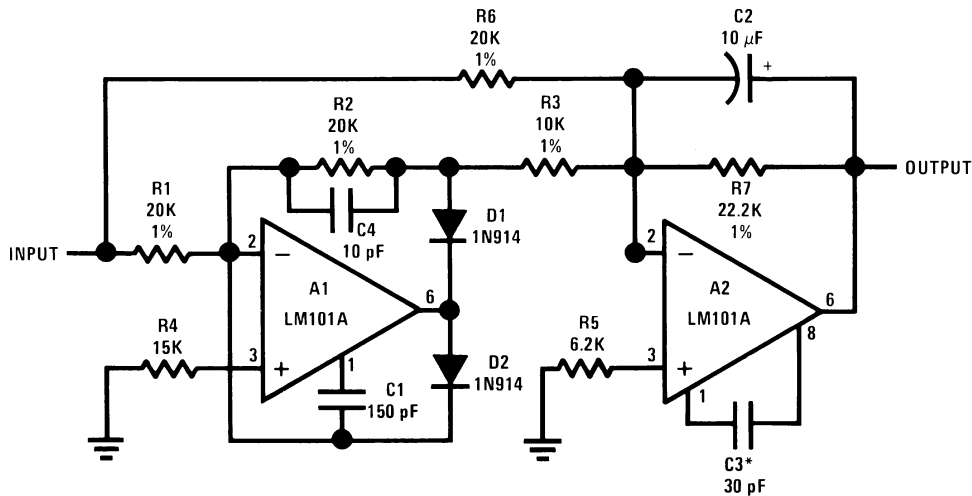

Note 1: Feedforward compensation can be used to make a fast full wave rectifier without a filter.

00775233

Absolute Maximum Ratings (Note 2)

If Military/Aerospace specified devices are required,
please contact the National Semiconductor Sales Office/

Distributors for availability and specifications.

	LM101A/LM201A	LM301A
Supply Voltage	±22V	±18V
Differential Input Voltage	±30V	±30V
Input Voltage (Note 3)	±15V	±15V
Output Short Circuit Duration (Note 4)	Continuous	Continuous
Operating Ambient Temp. Range	-55°C to +125°C (LM101A) -25°C to +85°C (LM201A)	0°C to +70°C
T_J Max		
H-Package	150°C	100°C
N-Package	150°C	100°C
J-Package	150°C	100°C
Power Dissipation at T _A = 25°C		
H-Package (Still Air)	500 mW	300 mW
(400 LF/Min Air Flow)	1200 mW	700 mW
N-Package	900 mW	500 mW
J-Package	1000 mW	650 mW
Thermal Resistance (Typical) θ_{JA}		
H-Package (Still Air)	165°C/W	165°C/W
(400 LF/Min Air Flow)	67°C/W	67°C/W
N Package	135°C/W	135°C/W
J-Package	110°C/W	110°C/W
(Typical) θ_{JC}		
H-Package	25°C/W	25°C/W
Storage Temperature Range	-65°C to +150°C	-65°C to +150°C
Lead Temperature (Soldering, 10 sec.)		
Metal Can or Ceramic	300°C	300°C
Plastic	260°C	260°C
ESD Tolerance (Note 7)	2000V	2000V

Electrical Characteristics (Note 5)

T_A = T_J

Parameter	Conditions	LM101A/LM201A			LM301A			Units
		Min	Typ	Max	Min	Typ	Max	
Input Offset Voltage	T _A = 25°C, R _S ≤ 50 kΩ		0.7	2.0		2.0	7.5	mV
Input Offset Current	T _A = 25°C		1.5	10		3.0	50	nA
Input Bias Current	T _A = 25°C		30	75		70	250	nA
Input Resistance	T _A = 25°C	1.5	4.0		0.5	2.0		MΩ
Supply Current	T _A = 25°C		V _S = ±20V	1.8	3.0			mA
			V _S = ±15V				1.8	3.0
Large Signal Voltage Gain	T _A = 25°C, V _S = ±15V V _{OUT} = ±10V, R _L ≥ 2 kΩ	50	160		25	160		V/mV
Input Offset Voltage	R _S ≤ 50 kΩ			3.0			10	mV
Average Temperature Coefficient of Input Offset Voltage	R _S ≤ 50 kΩ		3.0	15		6.0	30	μV/°C
Input Offset Current				20			70	nA
Average Temperature Coefficient of Input Offset Current	25°C ≤ T _A ≤ T _{MAX}		0.01	0.1		0.01	0.3	nA/°C
	T _{MIN} ≤ T _A ≤ 25°C		0.02	0.2		0.02	0.6	nA/°C
Input Bias Current				0.1			0.3	μA

Electrical Characteristics (Note 5) (Continued)

$$T_A = T_J$$

Parameter	Conditions	LM101A/LM201A			LM301A			Units
		Min	Typ	Max	Min	Typ	Max	
Supply Current	$T_A = T_{MAX}$, $V_S = \pm 20V$		1.2	2.5				mA
Large Signal Voltage Gain	$V_S = \pm 15V$, $V_{OUT} = \pm 10V$ $R_L \geq 2k$	25			15			V/mV
Output Voltage Swing	$V_S = \pm 15V$	$R_L = 10 k\Omega$	± 12	± 14		± 12	± 14	V
		$R_L = 2 k\Omega$	± 10	± 13		± 10	± 13	V
Input Voltage Range	$V_S = \pm 20V$	± 15						V
	$V_S = \pm 15V$		+15, -13		± 12	+15, -13		V
Common-Mode Rejection Ratio	$R_S \leq 50 k\Omega$	80	96		70	90		dB
Supply Voltage Rejection Ratio	$R_S \leq 50 k\Omega$	80	96		70	96		dB

Note 2: Absolute Maximum Ratings indicate limits beyond which damage to the device may occur. Operating ratings indicate for which the device is functional, but do not guarantee specific performance limits. Electrical Characteristics state DC and AC electrical specifications under particular test conditions which guarantee specific limits. This assumes that the device is within the Operating Ratings. Specifications are not guaranteed for parameters where no limit is given, however, the typical value is a good indication of device performance.

Note 3: For supply voltages less than $\pm 15V$, the absolute maximum input voltage is equal to the supply voltage.

Note 4: Continuous short circuit is allowed for case temperatures to $125^\circ C$ and ambient temperatures to $75^\circ C$ for LM101A/LM201A, and $70^\circ C$ and $55^\circ C$ respectively for LM301A.

Note 5: Unless otherwise specified, these specifications apply for $C_1 = 30 pF$, $\pm 5V \leq V_S \leq \pm 20V$ and $-55^\circ C \leq T_A \leq +125^\circ C$ (LM101A), $\pm 5V \leq V_S \leq \pm 20V$ and $-25^\circ C \leq T_A \leq +85^\circ C$ (LM201A), $\pm 5V \leq V_S \leq \pm 15V$ and $0^\circ C \leq T_A \leq +70^\circ C$ (LM301A).

Note 6: Refer to RETS101AX for LM101A military specifications and RETS101X for LM101 military specifications.

Note 7: Human body model, 100 pF discharged through 1.5 k Ω .

Typical Performance Characteristics

LM101A/LM201A

Input Voltage Range

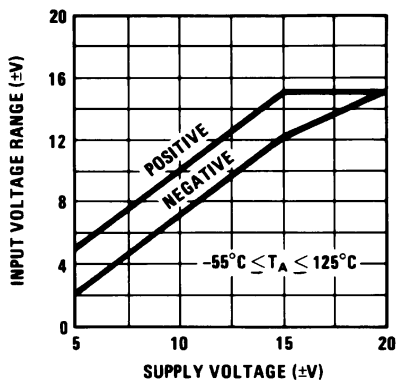

00775241

Output Swing

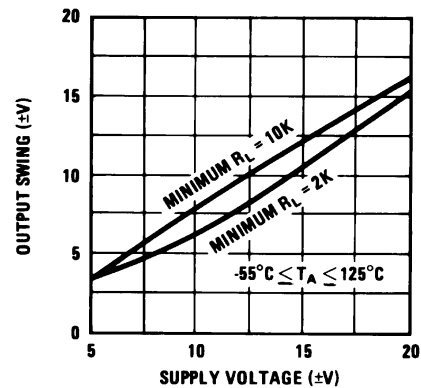

00775242

Physical Dimensions inches (millimeters)

unless otherwise noted

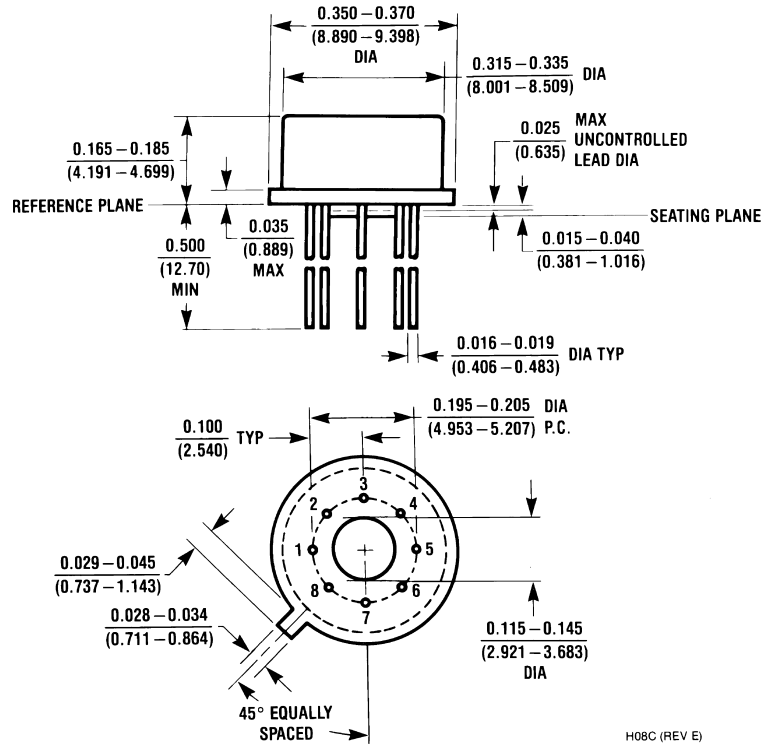

H08C (REV E)

Metal Can Package (H)
Order Number LM101AH, LM101AH/883
LM201AH or LM301AH
NS Package Number H08C

Physical Dimensions inches (millimeters) unless otherwise noted (Continued)

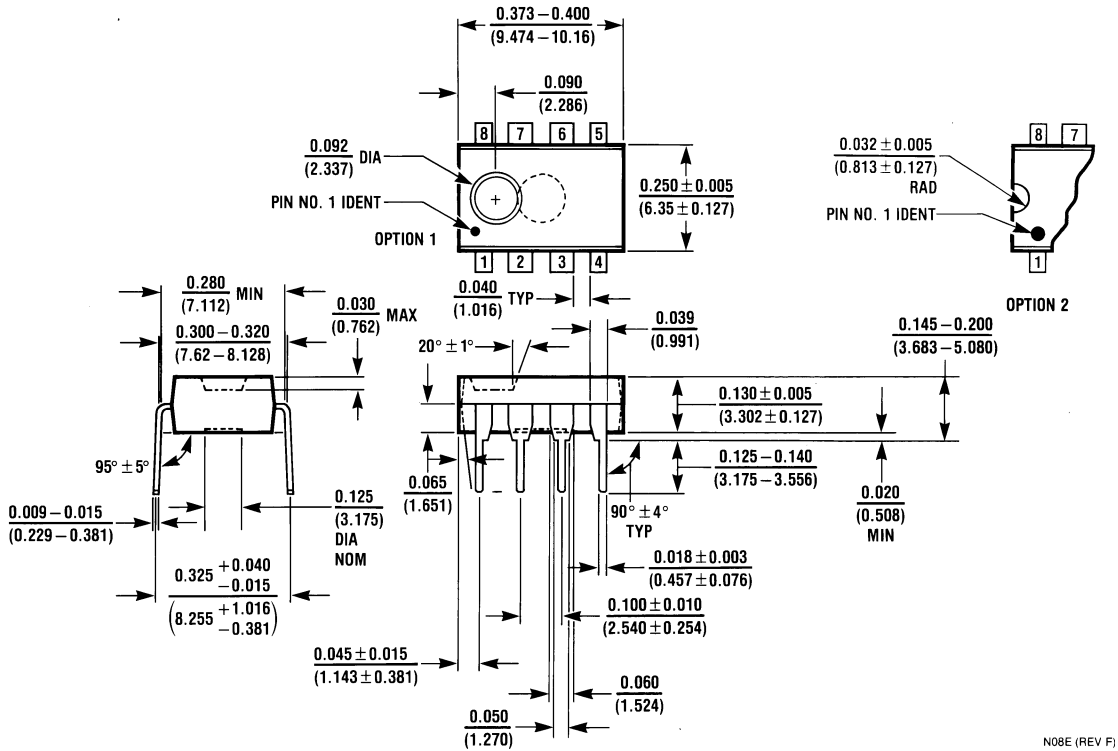

Molded Dual-In-Line Package (N)
Order Number LM201AN or LM301AN
NS Package Number N08E

N08E (REV F)

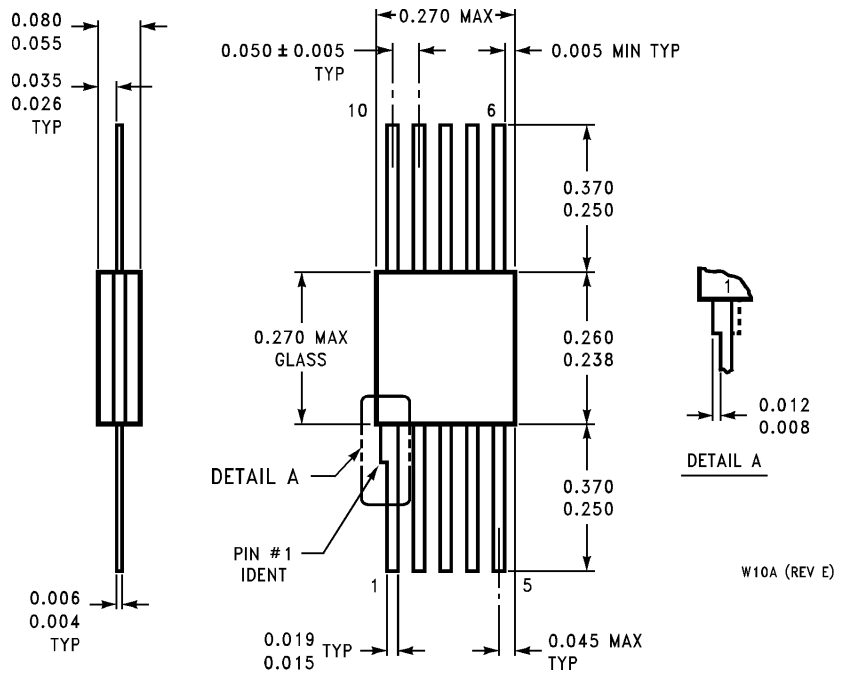

Ceramic Flatpack Package (W)
Order Number LM101AW/883 or LM101W/883
NS Package Number W10A

W10A (REV E)