

Utilization of the Relay Kit with the SDU Product Series:

Components supplied with the RELAYCARD-SDU kit:

- One Dry Contact Relay box
- One Interface Cable (DB 9 Connector)
- One 12VDC Power Interconnection Cable
- Four M3 Mounting Screws

Mounting Procedure:

- Step 1:** Using the four M3 screws provided, mount the dry relay box on the right side of the SDU UPS. If mounting on a separate chassis, the hole diameter for mounting the relay box is 0.378 Inch (3.5 mm).
- Step 2:** Plug the 12VDC Power Interconnection Cable into the 12VDC output of the SDU UPS. Plug the other end of the Power Interconnection Cable into the input of the relay box.
- Step 3:** Plug the DB 9 Connector Cable into the RS232 Communication Port of the SDU UPS. Plug the other end of the connector into the Remote Port of the dry contact relay.

Technical Services

U.S.A..... (800) 377-4384
International.....(847) 268-6000

www.solaheviduty.com

While every precaution has been taken to ensure accuracy and completeness in this manual, Sola/Hevi-Duty assumes no responsibility, and disclaims all liability for damages resulting from use of this information or for any errors or omissions.

© 2005 Sola/Hevi-Duty.

All rights reserved throughout the world. Specifications are subject to change without notice.

© Sola/Hevi-Duty name and logo are registered trademarks of EGS Electrical Group, LLC.

All names referred to are trademarks or registered trademarks of their respective owners.

P/N: A272-080
Rev. 5 (December 19, 2006)



Dry Contact Relay Kit

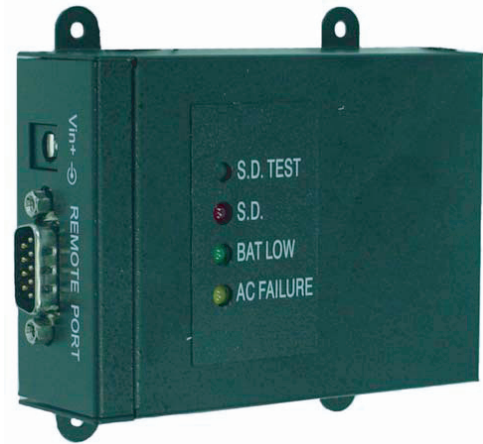

RELAYCARD-SDU

Instruction Manual

RELAYCARD-SDU: Front and Rear view

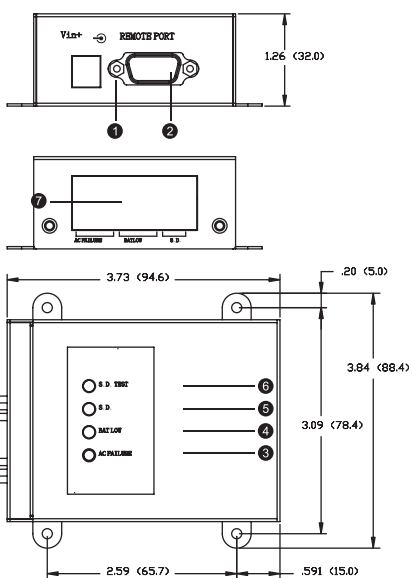

All dimensions in inches (mm)

- 1 Vin**
 Input connector used to provide the dry contact relay with 12 VDC input power.
- 2 Remote Port**
 The communication port is used for linking to UPS.
 Note: The provided connection cable is used only for this dry contact relay.
- 3 AC Failure indicator**
 This yellow LED is illuminated when AC Voltage is abnormal.
- 4 Battery low indicator**
 This green LED is illuminated when battery capacity is low.
- 5 Shut down indicator (S.D.)**
 When the Dry Contact Relay receives shut down signal over 1 second, the red LED is illuminated and the UPS goes into the shut down mode.
- 6 Shut down test button (S.D. Test)**
 Provide Dry Contact Relay a shut down signal to test the shut down function. Push this button over 1 second and the red LED is illuminated. UPS goes into the shut down mode.

1

7 8 poles terminal blocks

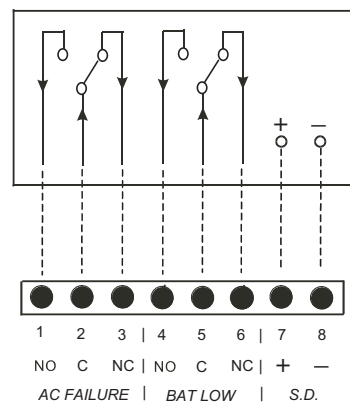

Terminal Block, Layout and Operation

+UPS State O: Occur X: does not occur		External Input O: Enable X: Disable	DCB LED Display O: LED ON X: LED OFF			Terminal blocks O: Close X: Open			
AC Failure	BAT Low	S.D.	YELLOW	GREEN	RED	1-2 PIN	2-3 PIN	4-5 PIN	5-6 PIN
X	X	X	X	X	X	X	O	X	O
O	X	X	O	X	X	O	X	X	O
O	O	X	X	O	X	O	X	O	X
O	X	O	X	X	O	X	O	X	O

NOTE 1: Suitable electric wire = AWG 22~12 (IEC 2.5mm)

NOTE 2: Contact Max current = 10A

NOTE 3: Shut down Input signal, range = +5V ~ +12V, can be provided by enabling terminals 7 and 8 for remote shut down control, assured by an external remote device.



ELECTRICAL SAFETY PRE-CAUTIONS MUST BE FOLLOWED WHEN INSTALLING OR SERVICING THIS EQUIPMENT. TO PREVENT RISK OF ELECTRICAL SHOCK, TURN OFF AND LOCK OUT ALL POWER SOURCES TO THE UNIT BEFORE MAKING ELECTRICAL CONNECTIONS OR SERVICING.

2