



We Tame Photons to Work for You!



Products

Search Tools

Solutions

Literature

Tech Notes

Support

Corporate

Products > LED Indicators > Panel Indicators > Round > Front Insertion > 5mm > Chrome Housing > Flush LED > 0.323" Panel Cutout > 2 Leaded



### Features / Options

- ▶ Bi-Color Styles Optional
- ▶ State-of-the-Art, LED Technology
- ▶ Choice of LED Colors and Lens Finishes
- ▶ Insulated Lead Lengths Optional
- ▶ Easy installation through panel

### Applications / Uses

- ▶ Front Panel Status Indicators
- ▶ Alarm/Warning Indicators
- ▶ Front Panel Circuit Fault Indicators
- ▶ Instrument Control Panels
- ▶ Medical Diagnostics Indicators
- ▶ Industrial Automation Control Panels

Part Number:	Brightness	Material	Emitted Color	Wavelength	Intensity	View Angle	Voltage
SSI-LXR4815BID-150	STANDARD	GaAsP	Blinking Red	635	600	30	3.0
SSI-LXR4815GD-150	STANDARD	Gap	Green	565	30	60	2.2
SSI-LXR4815GD5V150	STANDARD	GaP	Green	565	15	60	5.0
SSI-LXR4815HGW-150	STANDARD	GaP	Red/ Green	700/565	5/8	60	2.0/2.2
SSI-LXR4815ID-150	STANDARD	GaAsP	Red	635	40	60	2.0
SSI-LXR4815ID5V150	STANDARD	GaAsP	Red	635	20	60	5.0
SSI-LXR4815SID-150	HIGH	AlInGaP	Red	636	100	60	2.0
SSI-LXR4815SOD-150	HIGH	AlInGaP	Orange	610	100	60	2.0
SSI-LXR4815SRD-150	HIGH	GaAlAs	Red	660	300	60	1.8
SSI-LXR4815SUGD150	HIGH	AlInGaP	Green	574	250	60	2.2
SSI-LXR4815SYD-150	HIGH	AlInGaP	Yellow	590	200	60	2.1

UNCONTROLLED DOCUMENT

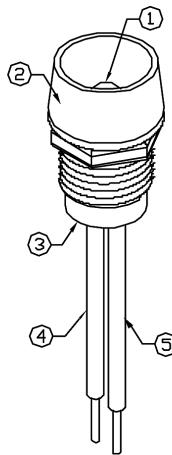
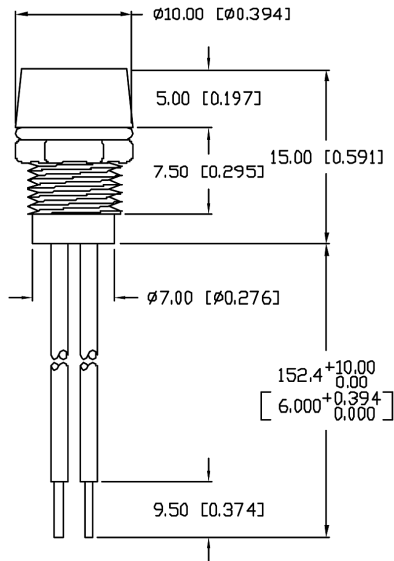

PANEL CUTOUT

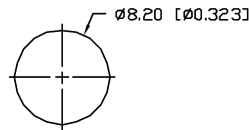

NOTES:

- 1. SSL-LX50B3GD, GREEN LED. TRIM LEADS TO 5mm.
- 2. SSI-LXR4815, CHROME HOUSING.
- 3. SSH-LXH4815BSC, BLACK NYLON BUSHING. (NOT SEEN)
- 4. ANODE LEAD: LXP-WST24RDT0C, RED INSULATION, 160mm LONG, STRIP 2mm & 9.5mm.
- 5. CATHODE LEAD: LXP-WST24BLT0C, BLACK INSULATION, 160mm LONG, STRIP 2mm & 9.5mm.

PART NUMBER		REV.
SSI-LXR4815GD-150		D
REV.	E.C.N. NUMBER AND REVISION COMMENTS	DATE
A	REDRAWN, UPDATED SAFE OPER. SPECS.	10.27.94
B	CORRECTED WIRE STRIP LENGTH.	11.17.94
C	E.C.N. #10674.	10.30.00
D	E.C.N. #10BRDR. & REDRAWN IN 3D.	1.10.02

ELECTRO-OPTICAL CHARACTERISTICS  $T_A=25^\circ\text{C}$   $I_f=20\text{mA}$

PARAMETER	MIN	TYP	MAX	UNITS	TEST COND
PEAK WAVELENGTH		565		nm	
FORWARD VOLTAGE		2.2	2.6	$V_f$	
REVERSE VOLTAGE	5.0			$V_r$	$I_f=100\mu\text{A}$
AXIAL INTENSITY		30		med	$I_f=20\text{mA}$
VIEWING ANGLE		60		2x theta	
EMITTED COLOR:	GREEN				
EPOXY LENS FINISH:	GREEN DIFFUSED				

LIMITS OF SAFE OPERATION AT 25°C

PARAMETER	MAX	UNITS
PEAK FORWARD CURRENT*	150	mA
STEADY CURRENT	25	mA
POWER DISSIPATION	105	mW
DERATE FROM 25°C	-1.2	mW/°C
OPERATING, STORAGE TEMP.	-40 TO +85	°C

\*  $t < 10\mu\text{s}$

\*UNLESS OTHERWISE SPECIFIED TOLERANCES PER DECIMAL PRECISION ARE: X=±1 (±0.039), XX=±0.5 (±0.020), XXX=±0.25 (±0.010), XXXX=±0.127 (±0.005). LEAD SIZE=±0.05 (±0.002), LEAD LENGTH=±0.75 (±0.030). MIN= -DECIMAL PRECISION MAX= +DECIMAL PRECISION

UNCONTROLLED DOCUMENT

REV. D	PART NUMBER SSI-LXR4815GD-150	<p><b>CONFIDENTIAL INFORMATION</b></p> <p>THE INFORMATION CONTAINED IN THIS DOCUMENT IS THE PROPERTY OF LUMEX INC. EXCEPT AS SPECIFICALLY AUTHORIZED IN WRITING BY LUMEX INC., THE HOLDER OF THIS DOCUMENT SHALL KEEP ALL INFORMATION CONTAINED HEREIN CONFIDENTIAL AND SHALL PROTECT SAME IN WHOLE OR IN PART FROM DISCLOSURE AND DISSEMINATION TO ALL THIRD PARTIES.</p> <p><b>RELIABILITY NOTE</b></p> <p>OUR MANY YEARS OF EXPERIENCE DATA ACCUMULATION INDICATE THAT SOLDER HEAT IS A MAJOR CAUSE OF EARLY AND FUTURE FAILURE. PLEASE PAY ATTENTION TO YOUR SOLDERING PROCESS.</p>	
T-5mm 565nm GREEN LED PANEL INDICATOR LED, GREEN DIFFUSED LENS, WITH 6" WIRE LEADS.			