

**COMPACT
FOOTSWITCH**



Compact Footswitch

Environmental Ratings:

EN 60529 Degree of Protection IP20

Key Benefits

This foot switch is compact in size and light in weight. Built for long life, the strong steel housing is painted black with nonskid base pad.

Size: 2-7/8" x 2-1/2" x 1-1/8"

Weight: 7 oz.

The TWIN 491-S foot switch consists of two single models mounted on a single cast aluminum base with a divider bar between pedals which helps prevent accidental operation of both pedals at one time.







Size: 6" x 2-7/8" x 1-7/16"

Weight: 1-1/4 lbs.

SPECIFICATIONS

(Special variations are available to the O.E.M. on special order on the models listed below)

⚠ WARNING

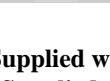
	CATALOG NUMBER	DESCRIPTION	CIRCUIT	FORM	ELECTRICAL RATINGS
	491-S	Momentary	SPDT	C	10 A 125-250 VAC 1/2 H.P. 125-250 VAC
	491-DA	Maintained	SPST	A	10 A 1/2 HP 125-250 VAC
	491-DC3A*	Maintained	SPST	A	10 A 1/2 HP 125 VAC
	491-SC3**	Momentary	SPDT Wired N.O.	A	10 A 125 VAC 1/2 H.P. 125 VAC
	491-SC36*** 491-SC36MP***	Momentary	SPDT Wired N.O.	A	10 A 125-250 VAC 1/2 H.P. 125-250 VAC
	TWIN 491-S	Momentary	Each Side SPDT	C	10 A 125-250 VAC 1/2 H.P. 125-250 VAC
	491-DC36A****	Maintained	SPST	A	10 A 125-250 VAC 1/2 H.P. 125-250 VAC
	492-S	Momentary	SPDT	C	20 A 125-250 VAC 1 H.P. 125-250 VAC

*Supplied with 6 ft. 18/3 cord and 3 prong series plug. Green lead grounded.

**Supplied with 8 ft. 16/3 cord with 3 prong series plug. Green lead grounded.

***Supplied with 6 ft. 16/3 cord without plug. Green lead grounded.

****Supplied with 6 ft. 18/3 cord without plug(Green Lead Grounded)

BOLD COPY INDICATES STOCK ITEM

Compact Single Model

NOTE: ALL DIMENSIONS ARE FOR REFERENCE ONLY.

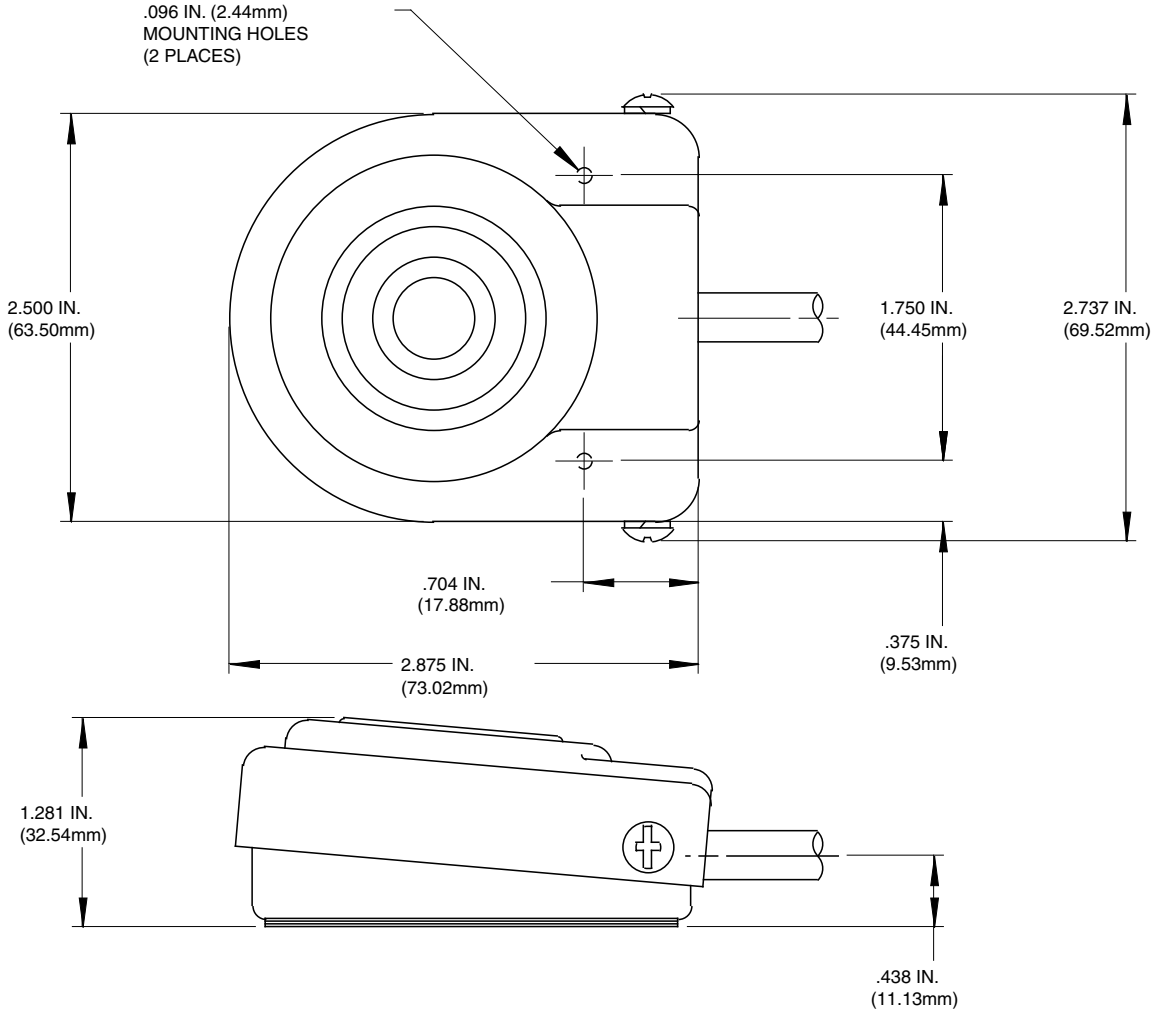

EN 60529 Degree of Protection IP20

Splash Resistant (Available Momentary Only)
VERSATILE COMPACT DESIGN

Materials of Construction:

- Steel housing is painted Black
- Metal Mounting Plate spot welded to base on 491-SC36MP
- Twin Baseplate formed from cast aluminum
- The two pedal model is supplied with a divider bar between pedals which helps prevent accidental operation of both pedals at one time

Features & Benefits:

- Momentary & Maintained Models Non-Skid base pad for secure placement
- Compact in size and light in weight
- Supplied with internal adjustable strain relief
- Built for long life
- 2 Mounting Holes for Rigid Mounting to Floor or Equipment

Options:

- Rectangular mounting bracket is available for Compact models on special order. Bracket comes spot-welded to switch base and has two clearance holes for mounting
- Heavy gauge steel guard available (See "Accessories - Guards" on page 74 & 75 for details)
- Airval models available (See "Compact Pneumatic Airval" on page 55 for details)



Single	
Size (HxWxD):	2.88 x 2.50 x 1.13 In.
Weight:	7.00 oz.
Twin	
Size (HxWxD):	6.00 x 2.89 x 1.44 In.
Weight:	1.25 lbs.
Mounting Bracket Model	
Size (HxWxD):	2.88 In. x 3.50 x 1.29 In.
Weight:	8.00 oz.

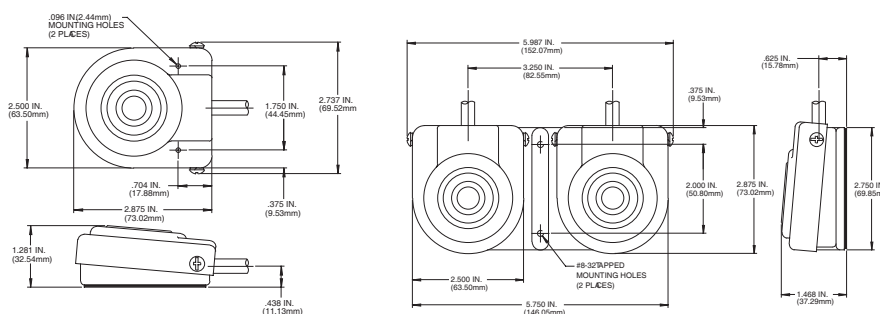

WARNING SEE PRODUCT WARNING ON PAGE 8

SPECIFICATIONS (Special variations are available to the O.E.M. on special order on the models listed below)

AGENCY APPROVALS	EN 60529 Degree of Protection	CATALOG NUMBER	DESCRIPTION	CIRCUIT	FORM	ELECTRICAL RATINGS
cRUUS CB CE	IP20	491-S	Single / Momentary	SPDT	C	10 A 125-250 VAC 1/2 H.P. 125-250 VAC
UL CB CE	IP20	491-SC36 ¹	Single / Momentary	SPDT Wired N.O.	A	
cRUUS CE	IP20	491-DA	Single / Maintained	SPST	A	
cULUS CE	IP20	491-DC36A ²	Single / Maintained	SPST	A	
cRUUS CB	IP20	491-SC3 ³	Single / Momentary	SPDT Wired N.O.	A	10 A 125-250 VAC 1/2 H.P. 125-250 VAC
cULUS	IP20	491-DC3A ⁴	Single / Maintained	SPST	A	
cRUUS CE	IP20	492-S	Single / Momentary	SPDT	C	20 A 125-250 VAC 1 H.P. 125-250 VAC
cRUUS CB CE	IP20	TWIN 491-S	Twin / Momentary	SPDT - Each Side	C	10 A 125-250 VAC 1/2 H.P. 125-250 VAC
UL CB CE	IP20	491-SC36MP ¹	Single / Momentary with Mounting Plate	SPDT Wired N.O.	A	10 A 125-250 VAC 1/2 H.P. 125-250 VAC

¹Supplied with 6 ft. 16/3 cord with 3 prong series plug. Green lead grounded. ²Supplied with 6 ft. 18/3 cord without plug. Green lead grounded. ³Supplied with 8 ft. 16/3 cord with 3 prong series plug. Green lead grounded. ⁴Supplied with 6 ft. 16/3 cord without plug. Green lead grounded.